

Strut systems



Eaton and Cooper united.
**Energizing a world
that demands more.**

Discover today's Eaton.

Powering business worldwide

As a global diversified power management company, we help customers worldwide manage the power needed for buildings, aircraft, trucks, cars, machinery and businesses.

Eaton's innovative technologies help customers manage electrical, hydraulic and mechanical power more reliably, efficiently, safely and sustainably.

EATON

Powering Business Worldwide



We deliver:

- **Electrical solutions** that use less energy, improve power reliability and make the places we live and work safer and more comfortable
- **Hydraulic and electrical solutions** that enable machines to deliver more productivity without wasting power
- **Aerospace solutions** that make aircraft lighter, safer and less costly to operate, and help airports operate more efficiently
- **Vehicle drivetrain and powertrain solutions** that deliver more power to cars, trucks and buses, while reducing fuel consumption and emissions

We provide integrated solutions that help make energy, in all its forms, more practical and accessible.

With 2012 sales of \$16.3 billion, Eaton has approximately 103,000 employees around the world and sells products in more than 175 countries.

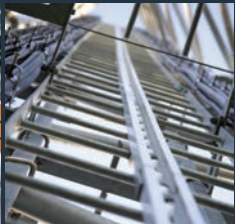
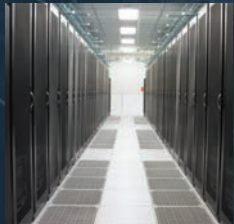

Eaton's electrical business

Eaton is a global leader with expertise in:

- Power distribution and circuit protection
- Backup power protection
- Solutions for harsh and hazardous environments
- Lighting and security
- Structural solutions and wiring devices
- Control and automation
- Engineering services

Eaton is positioned through its global solutions to answer today's most critical electrical power management challenges. With 100 years of electrical experience behind us, we're energized by the challenge of powering up a world that demands twice as much energy as today. We're anticipating needs, engineering products, and creating solutions to energize our markets today and in the future.

We are dedicated to ensuring that reliable, efficient and safe power is available when it's needed most.

Eaton.com

Table of Contents

B-Line is a leading manufacturer and fabricator of steel and aluminum products which are used in support of equipment for industrial, commercial, utility, and OEM installations. B-Line is proud of the exacting standards of research, design, engineering, and manufacturing that go into each and every product that comprise our strut product line. Our customers have access to the most complete support systems offered in the industry, including metal framing, cable tray, pipe hangers, slotted angle, and fasteners.

Many of B-Line's products are listed by the Underwriter's Laboratories, Inc. All B-Line products are manufactured to meet or exceed Metal Framing Manufacturers Association (MFMA) and other industry standards set for their design and manufacture.

Eaton's B-Line Business

509 West Monroe Street
 Highland, Illinois 62249-0326
 Phone: 800-851-7415
 www.cooperbline.com



Metal Framing Manufacturers Association

Introduction	2-3
---------------------	-----

Technical Data	
Materials & Finishes	4-6
Welding & Corrosion	7-9
Design of Strut Systems & Recommended Specification	10-13



Channel & Combinations	
Info. & Specifications & Selection Chart	14-15
B11 Channel	16-17
B12 Channel	18-19
B22, B24, B26 Channels	20-27
B32 Channel	28-29
B42 Channel	30-31
B52, B54, B56 Channels	32-37
Telescoping Channel	38-39
Channel Hole Patterns	40-42

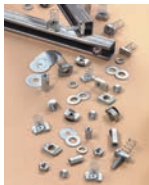

Channel Nuts & Hardware	
Info. & Specifications	44
Channel Nuts Selection Charts	45-49
Channel Nuts Slip & Pull-out Load Charts	50-51
Other Hardware	52-58
KwikWire™ & Accessories	59-70



Strut Fittings	
Info. & Specifications	72
Flat Plate Fittings	73-75
90° Angle Fittings	76-81
Angular Fittings	82-84
Braces	85
Clevis Fittings	86
U-Fittings	87-90
Z-Fittings	91-93
Wing Fittings	94-96
Post Bases	97-98
Brackets	99-105
Miscellaneous Fittings	106-111

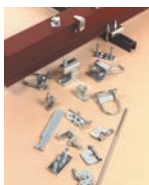

Beam Clamps & Accessories	
Info. & Specifications	112
Beam Clamps & Accessories	113-125

Table of Contents



Pipe/Conduit Clamps & Hangers

Info. & Specifications	126
Pipe Clamps & Vibra Clamps	127-135
Armafix™ Clamps & Accessories	136
Vibra Cushions	137
Pipe Clamps, Hangers, & Brackets	138-145
Pipe Block & Rollers	146-151



DURA-BLOK™ Rooftop Supports

Info. & Specifications	152
Base Support - With & Without Channel	154
Base Support - Pipe/Tubing Riser	154
Base Support Riser - Channel & Pipe Roller	155
Base Support - 'H' Stand	156-157
Base Support - Pipe Roller	158
Application & Roof-Top Walkway Photos	159-160
Solar Application Photos	161



Electrical Accessories

Info. & Specifications	162
Selection Chart	163
Fluorescent Fixture Hangers	164-166
Electrical Accessories	167-168
Junction Boxes & Strut Joiners	169-171
Electrical Hardware	172
Porcelain & Maple Clamps	173-175



Aluminum & Stainless Steel Materials

Info. & Specifications	176
Aluminum	177-179
Stainless Steel	180-181



Fiberglass Materials

Info. & Specifications	182-183
Channels	184-188
Hardware	188-190
Fittings	191-199



Mini Channel & Fittings

Info. & Specifications	200
Mini Channels & Channel Nuts	201-203
Mini Fittings	203-211



Concrete Inserts

Info. & Specifications	212-213
Continuous Inserts	214-216
Spot Inserts	217
Insert Accessories	218
Anchors	219-221



Slotted Angle

Info. & Specifications	222
Slotted Angle	
Sizes	223
Loading Charts	224-226
Slotted Angle Fittings	227

Reference Data	228-237
-----------------------------	---------

Tolco to B-Line Cross	238-240
------------------------------------	---------

Index	241-248
--------------------	---------

Introduction

Our strut support system is designed with many time-saving features. They are fully adjustable and reusable, with a complete line of channels, fittings and accessories for multi-purpose applications.

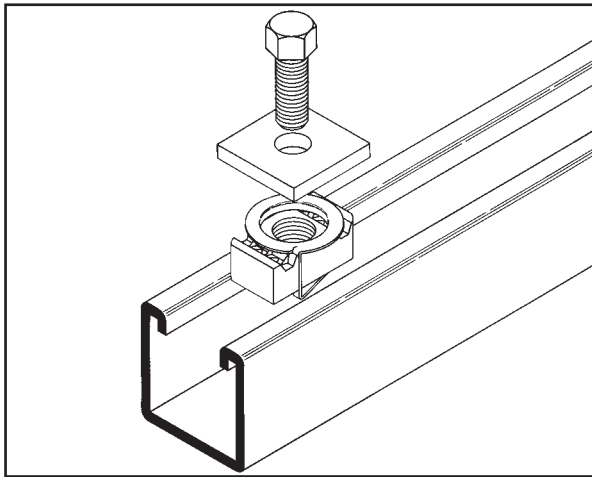

- No Welding
- No Drilling
- Use Your Imagination

The strut system installs quickly, with no need for special tools. All you need is a wrench and hacksaw.

Channels and parts can be taken apart for reuse as quickly as they were assembled, yet help provide the strength of welded construction. This eliminates welding and drilling which can have substantial savings in time and labor.

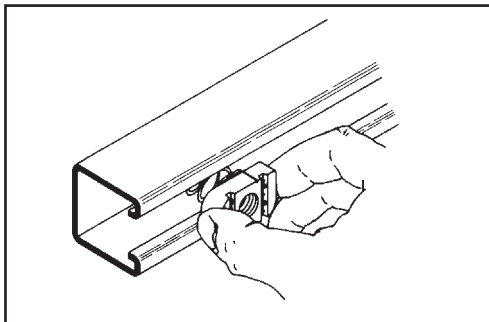

1. Channel nut may be inserted anywhere along continuous slot. Designed for easy insertion and self-alignment.

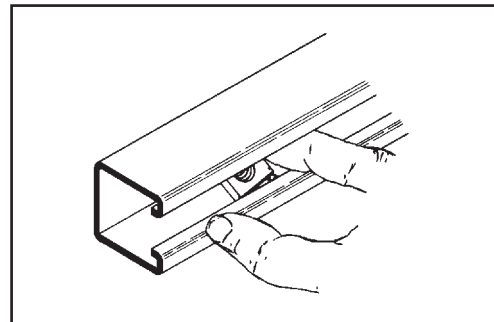

2. A 90° turn aligns channel nut grooves with inturned lips of the channel.

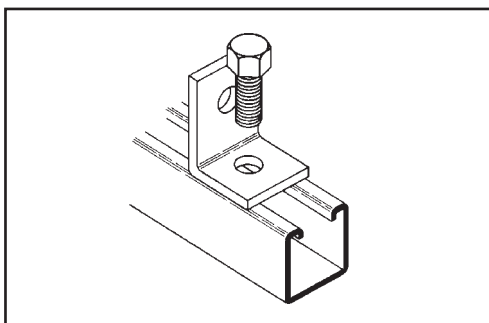

3. Position fitting over channel nut and insert bolt to start any connection.

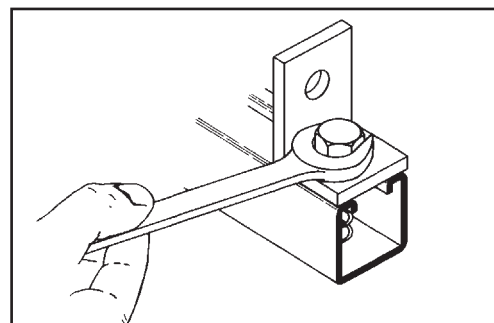

4. With the twist of a wrench, channel nut locks its teeth firmly against inturned lips.

Our strut system provides an economical solution for electrical, mechanical and industrial supports with an unlimited variety of applications in the construction industry.

Electrical Applications

- Lighting Fixture Supports
- Raceway Systems
- Trapeze Hangers
- Pipe & Conduit Supports
- Cable Tray Supports
- Beam Adjustments

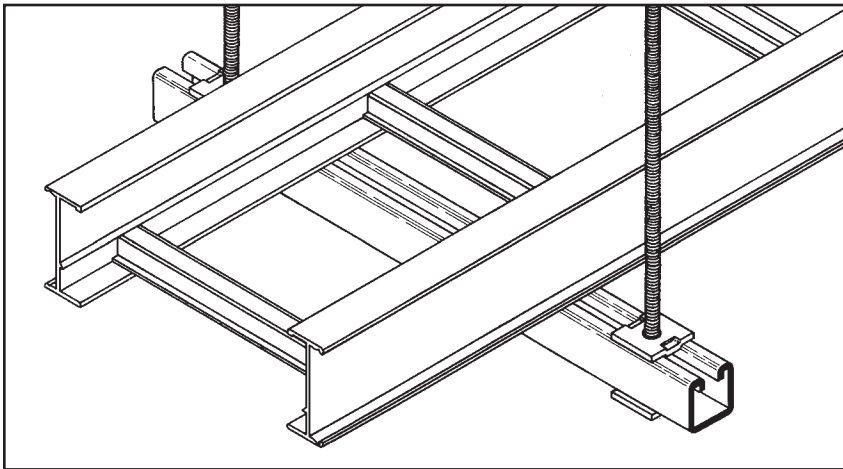
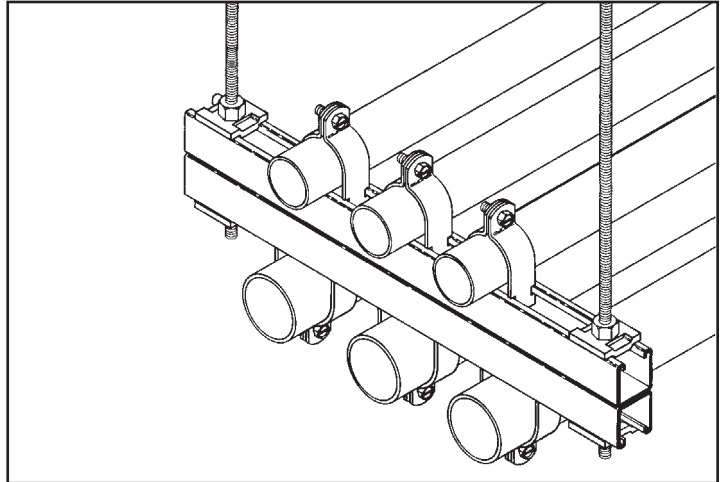

Mechanical Applications

- Piping Racks
- Tunnel Pipe Stanchions
- Concrete Inserts
- Beam Attachments
- Pipe Risers

Industrial Applications

- Racks and Shelving
- Partitions
- Production Line Supports
- Trolley Systems
- Wall Framing

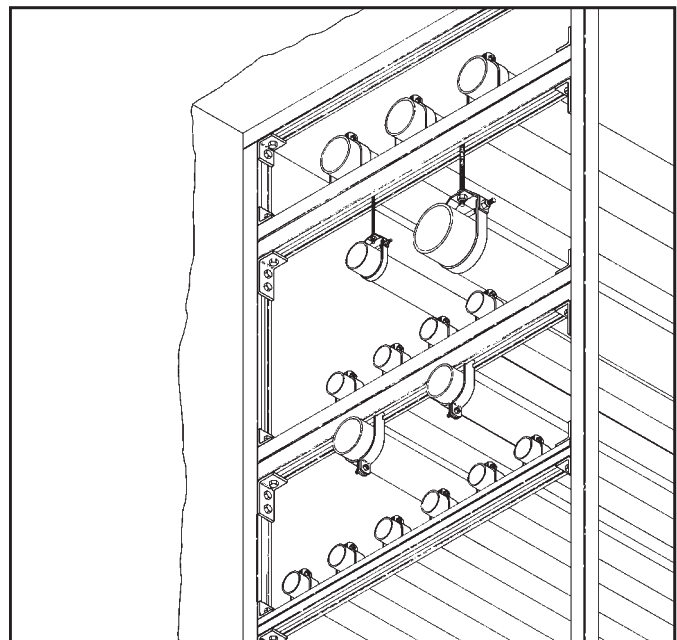

Technical Data

MATERIALS

Carbon Steel

Channels made from high-quality carbon steel are continuously roll formed to precise dimensions. By cold working the steel mechanical properties are increased, allowing lightweight structures to carry the required load. Corrosion resistance of carbon steel varies widely with coating and alloy. See "Finishes" for more detailed information.

Stainless Steel

Stainless steel channel is available in AISI Type 304 or 316 material. Both are non-magnetic and belong to the austenitic stainless steels group, based on alloy content and crystallographic structure. Like carbon steel, stainless steel exhibits increased strength when cold worked by roll-forming.

Several conditions make the use of stainless steel ideal. These include reducing long term maintenance costs, high ambient temperatures, appearance, and stable structural properties such as yield strength, and high creep strength.

Type 304 resists most organic chemicals, dyestuffs and a wide variety of inorganic chemicals at elevated or cryogenic temperatures. Type 316 contains slightly more nickel and adds molybdenum to give it better corrosion resistance in chloride and sulfuric acid environments. For more information concerning the differences between types 304 and 316, visit www.cooperblineline.com/contactus.

Aluminum

Standard aluminum channel is extruded from aluminum alloy 6063-T6. Strut fittings are made from aluminum alloy 5052-H32.

The high strength to weight ratio of channel made of aluminum helps greatly reduce the overall cost of installation through ease of handling and field cutting.

Aluminum owes its excellent corrosion resistance to its ability to form an aluminum oxide film that immediately reforms when scratched or cut. In most outdoor applications, aluminum has excellent resistance to "weathering". The resistance to chemicals, indoor or outdoor, can best be determined by tests conducted by the user with exposure to the specific conditions for which it is intended. The corrosion resistance of aluminum to some commonly known chemicals is shown in the Corrosion Chart. For further information, contact us or the Aluminum Association.

Fiberglass

We offer two fire retardant (FR) resins for strut systems, polyester and vinyl ester. Both resins are ideal for corrosive environments or nonconductive applications with moderate strength requirements. Some common types of environments where Vinyl Ester Resins are recommended, that Poly Esters are not, are paper mills, most any metal plating operation and any condition with

concentrated levels of Chlorine, [Cl⁻]. Please consult our fiberglass corrosion resistance charts on pg. 183 for specific chemical recommendation data.

Unlike other base materials depicted in this catalog, fiberglass exhibits unique physical property changes when operating in elevated temperature conditions that are a fraction of increase compared to steel or aluminum. Thus, it is advised against using fiberglass in temperatures greater than 200° F.

Please refer to the "Corrosion Resistance Guide" below for specific applications.

The fiberglass strut systems are manufactured from glass fiber-reinforced plastic shapes that meet ASTM E-84, Class 1 Flame Rating and self-extinguishing requirements of ASTM D-635. A surface veil is applied during pultrusion to insure a resin-rich surface and ultraviolet resistance.

While polyester is sufficient for most uses, vinyl ester is suitable for a broader range of environments.

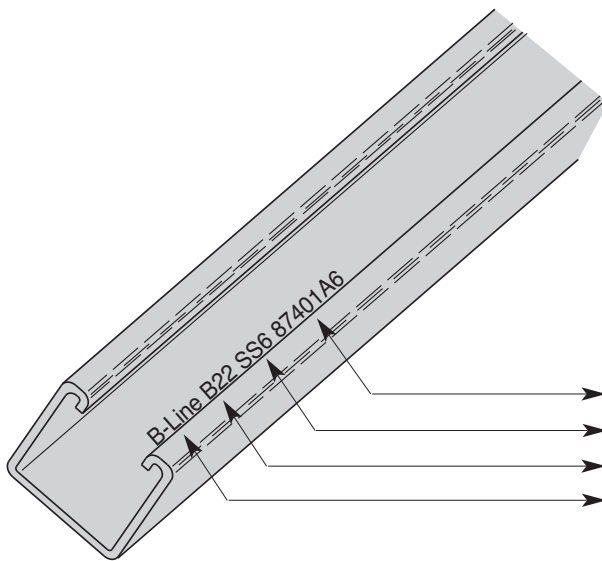

B-Line Steel Strut is stamped with:

- Traceable to the steel's origin
- Material/Finish
- B-Line part number designation
- Company Name

FINISHES

Zinc Coatings

Zinc protects steel in two ways. First it protects the steel as a coating and second as a sacrificial anode to repair bare areas such as cut edges, scratches, and gouges. The corrosion protection of zinc is directly related to its thickness and the environment. This means a .2 mil coating will last twice as long as a .1 mil coating in the same environment.

Galvanizing also protects cut and drilled edges.

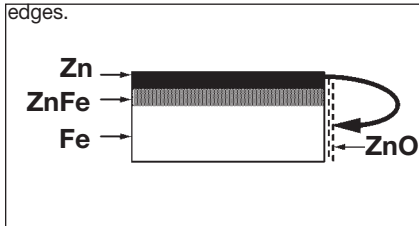

Electrogalvanized Zinc

Electrogalvanized Zinc (also known as zinc plated or electroplated) is the process by which a coating of zinc is deposited on the steel by electrolysis from a bath of zinc salts.

A rating of SC3, our standard, provides a minimum zinc coating thickness of .5 mils (excluding hardware, which is SC1 = .2 mils).

When exposed to air and moisture, zinc forms a tough, adherent, protective film consisting of a mixture of zinc oxides, hydroxides, and carbonates. This film is in itself a barrier coating which slows subsequent corrosive attack on the zinc. This coating is usually recommended for indoor use in relatively dry areas, as it provides ninety-six hours protection in salt spray testing per ASTM B117.

Chromium/ Zinc

Chromium/ Zinc is a corrosion resistant composition, which was developed to protect fasteners and small bulk items for automotive use. The coating applications have since been extended to larger parts and other markets.

Chromium/Zinc composition is an aqueous coating dispersion containing chromium, proprietary organics, and zinc flake.

This finish provides 500 hours protection in salt spray testing per ASTM B117.

Pre-Galvanized Zinc

(Mill galvanized, hot dip mill galvanized or continuous hot dip galvanized) Pre-galvanized steel is produced by coating coils of sheet steel with zinc by continuously rolling the material through molten zinc at the mills. This is also known as mill galvanized or hot dip mill galvanized. These coils are then slit to size and fabricated by roll forming, shearing, punching, or forming to produce our pre-galvanized strut products.

The G90 specification calls for a coating of .90 ounces of zinc per square foot of steel. This results in a coating of .45 ounces per square foot on each side of the sheet. This is important when comparing this finish to hot dip galvanized after fabrication.

During fabrication, cut edges and welded areas are not normally zinc coated; however, the zinc near the uncoated metal becomes a sacrificial anode to protect the bare areas after a short period of time.

Hot Dip Galvanized After Fabrication (Hot dip galvanized or batch hot dip galvanized)

Hot dip galvanized strut products are fabricated from steel and then completely immersed in a bath of molten zinc. A metallic bond occurs resulting in a zinc coating that completely coats all surfaces, including edges and welds.

Another advantage of this method is coating thickness. Strut products that are hot dip galvanized after fabrication have a minimum thickness of 1.50 ounces per square foot on each side, or a total 3.0 ounces per square foot of steel, according to ASTM A123.

The zinc thickness is controlled by the amount of time each part is immersed in the molten zinc bath as well as the speed at which it is removed. The term "double dipping" refers to parts too large to fit into the galvanizing kettle and, therefore, must be dipped one end at a time. It does not refer to extra coating thickness.

The layer of zinc which bonds to steel provides a dual protection against corrosion. It protects first as an overall barrier coating. If this coating happens to be scratched or gouged, zinc's secondary defense is called upon to protect the steel by galvanic action.

Hot-Dip Galvanized After Fabrication is recommended for prolonged outdoor exposure and will usually protect steel for 20 years or more in most atmospheric environments and in many industrial environments. For best results, a zinc rich paint (available from B-Line) should be applied to field cuts. The zinc rich paint will provide immediate protection for these areas and eliminate the short time period for galvanic action to "heal" the damaged coating.

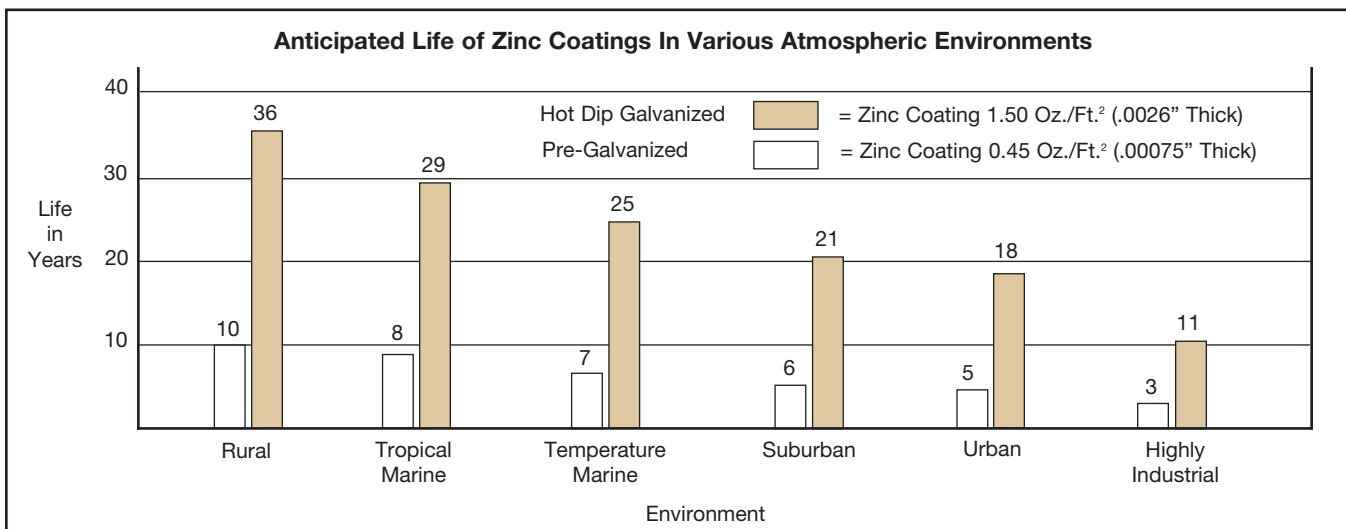

Technical Data

DURA-GREEN™ and DURA-COPPER™ Epoxy Coatings

DURA-GREEN and DURA-COPPER epoxy coatings are water borne epoxy coatings applied to B-Line products by a precisely controlled cathodic electro-deposition process. This process is accomplished using a conveyor to transport channel and fittings through several cleaning, phosphatizing and application stages prior to being baked (See diagram below).

This custom-designed paint system is used for painting all channels, channel combinations, slotted angle, and fittings.

Samples are selected on a routine basis for Salt Spray (fog) testing to verify the quality of the finish. These tests are performed in accordance with ASTM B117 and evaluated and related according to ASTM D1654 (Tables 1 & 2).

The DURA-GREEN and DURA-COPPER Epoxy coatings have been tested and listed by Underwriters Laboratories in accordance with "Standard for Surface Metal Raceway and Fittings, UL5" and

"Standard for Pipe Hanger Equipment for Fire Protection Service, UL203".

Due to DURA-GREEN's organically based composition, it seats itself into porous surfaces more completely and efficiently than zinc coatings. As these porous caverns are filled along the material profile, the outer finished surface demonstrates an increased smooth uniform plane which produces considerably less off-gasing when tested.

DURA-GREEN channel meets or exceeds 100 level clean room standards. This was confirmed by testing the channel in accordance with Boeing (PCL) Standards, which are more stringent and complete than ASTM E595-93. DURA-GREEN was found to be a superior finish, due in part to its proven application process.

PVC Coating

Another of the corrosion resistant coatings offered by B-Line is PVC (polyvinyl chloride), applied over steel or aluminum channel and fittings. The PVC coating process begins by cleaning the product

thoroughly. A bonding coat is applied to the part and then preheated to a temperature above the melting point of the coating powder. The product is then passed through a fluidized bed of vinyl plastic powder where the powder particles melt, adhere and flow out to form a smooth continuous coating. The thickness is controlled by the base metal temperature and the immersion time in the bed. It is then post-heated to complete the fusion of the outer surfaces.

The standard coating thickness of B-Line's PVC coated products is 15 mils (.380 mm), plus or minus 5 mils (.125 mm). Since the chemistry, not the thickness of vinyl plastic PVC determines longevity, a coating of 10 to 20 mils (.250 to .500 mm) is more than adequate. If the corrosive conditions are such that the plasticizers are leached out, a thicker coating will do little to extend the life of a coated product.

For certain environments, a plastisol dipped PVC coating is available on request.

PVC coating depends totally on the concept of encapsulation attached to the base metal by a bonding agent. If any hole or discontinuity occurs, the corrosive action can undercut the base metal to a point where all that remains is the PVC.

In the event of field cuts or any other damage to the coating, a liquid PVC patch, available from B-Line, must be applied to maintain the integrity of the coating. After the installation is complete, a thorough inspection should be performed to assure the absence of voids, pinholes, or cuts.

SALT SPRAY TEST RESULTS

Type of Finish	Unscribed 5% Failure (1)	Scribed 1/8" (3.2) Creepage from Scribe (1)
B-Line DURA-GREEN Epoxy	1000 Hours	312 Hours
Mill Galv. (Pre-Galv.) G90	192 Hours	288 Hours
Perma-Green	438 Hours	231 Hours
Zinc Chromate	36 Hours	96 Hours
Industry Green (Range)	10 to 36 Hours	4 to 30 Hours

(1) All salt spray (fog) tests conducted in accordance with ASTM B117 and evaluated and rated according to ASTM D1654 Tables 1 & 2. Tests are performed and certified by an independent testing laboratory.

DURA-GREEN™/DURA-COPPER™ EPOXY COATING PROCESS

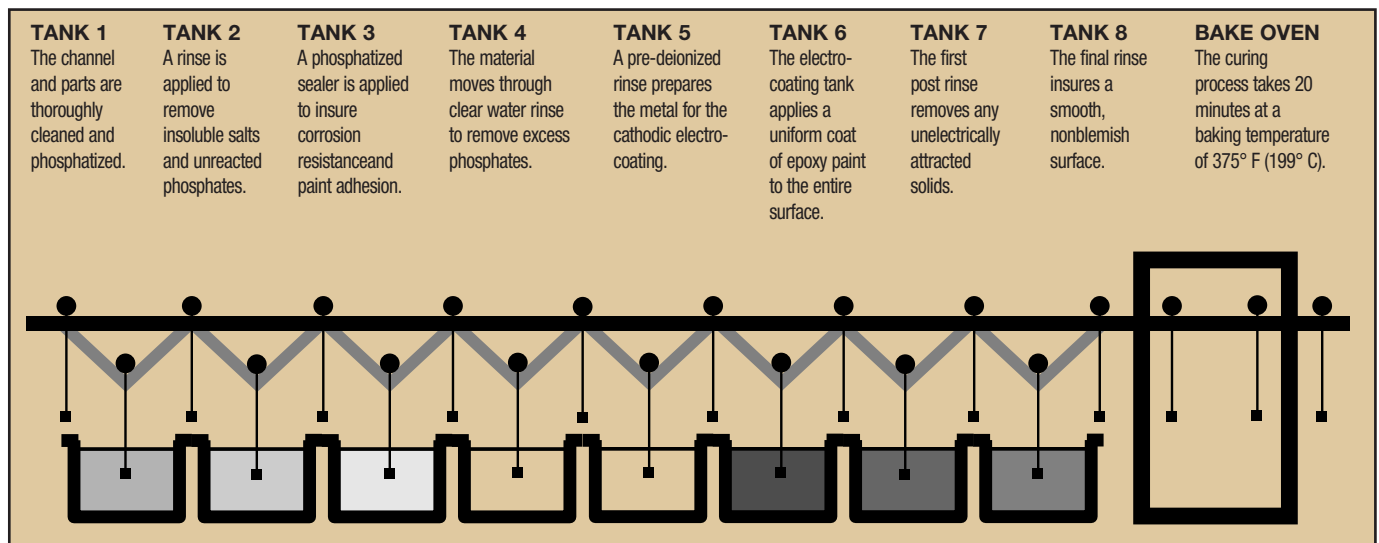

WELDING

The welding procedures used in the fabrication of our steel products are in accordance with American Welding Society Standards. To achieve the highest quality in our manufacturing processes, our welders follow standards set by AWS Code.

Spot Welding

Spot welded back-to-back channel is manufactured using a modern DC powered resistance welder controlled by a microprocessor. This produces a series of spot welds with speed and consistency. Consistency is one of the most important advantages in specifying back-to-back channel. Variables such as

weld sequence, speed and duration are carefully controlled and monitored by a sophisticated electronic control system. A statistical quality control program, combining destructive and non-destructive testing, is used to ensure high quality welds.

MIG Welding

MIG welded, more properly called gas metal arc welded (GMAW) combination channels and fittings, are produced when physical dimensions or certain combinations require a weld process other than automatic spot welding. The same quality control requirements are imposed on MIG welded and spot-welded products.

Quality Assurance

Our Quality Assurance Program has been developed and implemented for compliance with ISO9001:2008. We also complies with various industry standards and specifications. We have extensive experience in supplying metal framing components for the nuclear power generating industry, and upon request can provide products in compliance with 10CFR50 Appendix B, NQA-1 and 10CFR21. For more information on our quality capability please visit www.cooperblineline.com/nuclear.

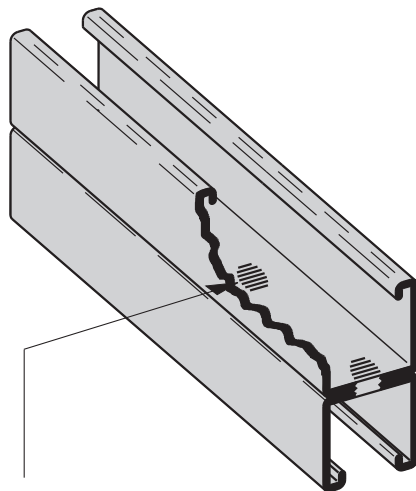

Spot Weld

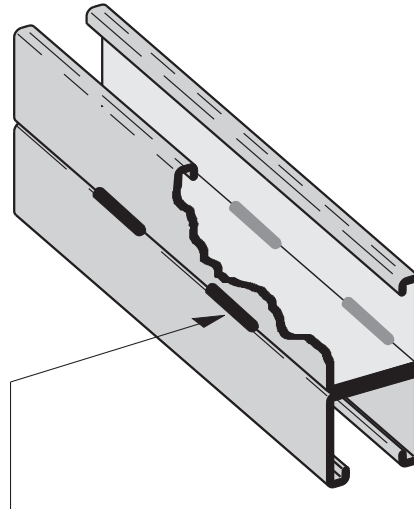

MIG Weld

CORROSION

All metal surfaces are affected by corrosion. Depending on the physical properties of the metal and the environment to which it is exposed, chemical or electromechanical corrosion may occur.

Atmospheric Corrosion

Atmospheric corrosion occurs when metal is exposed to airborne liquids, solids or gases. Some sources of atmospheric corrosion are moisture, salt, dirt and sulphuric acid. This form of corrosion is typically more severe outdoors, especially near marine environments.

Chemical Corrosion

Chemical corrosion takes place when metal comes in direct contact with a corrosive solution. Some factors which affect the severity of chemical corrosion include: chemical concentration level, duration of contact, frequency of washing, and operating temperature.

Storage Corrosion

Wet storage stain (white rust) is caused by the entrapment of moisture between surfaces of closely packed and poorly ventilated material for an extended period. Wet storage stain is usually superficial, having no affect on the properties of the metal.

Light staining normally disappears with weathering. Medium to heavy buildup should be removed in order to allow the formation of normal protective film. Proper handling and storage will help to assure stain-free material. If product arrives wet, it should be unpacked and dried before storage. Dry material should be stored in a well ventilated "low moisture" environment to avoid condensation formation. Outdoor storage is undesirable, and should be avoided whenever possible.

Galvanic Corrosion

Galvanic corrosion occurs when two or more dissimilar metals are in contact in the presence of an electrolyte (ie. moisture). An electrolytic cell is created and the metals form an anode or a cathode depending on their relative position on the Galvanic Series Table. The anodic material will be the one to corrode. Anodic or cathodic characteristics of two dissimilar metals will depend on the type of each material. For example: If zinc and steel are in contact, the zinc acts as the anode and will corrode; the steel acts as the

GALVANIC SERIES IN SEA WATER

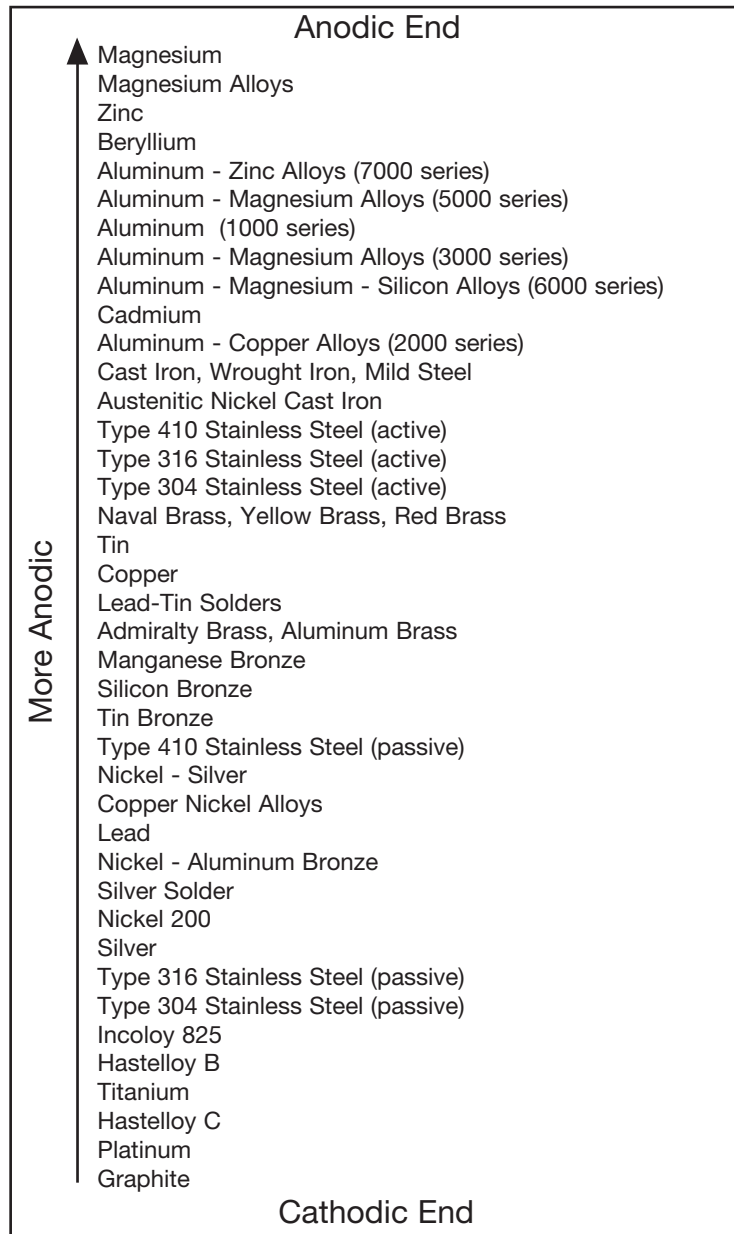

Metals in descending order of activity in the presence of an electrolyte.

cathode, and will be protected. If steel and copper are in contact, the steel is now the anode and will corrode. The rate at which galvanic corrosion occurs depends on several factors:

1. The relative position on the Galvanic Series Table - the further apart materials are in the Galvanic Series Table, the greater the potential for corrosion of the anodic material.

2. The amount and concentration of electrolyte present - an indoor, dry environment will have little or no galvanic corrosion compared to a wet atmosphere.

3. The relative size of the materials - a small amount of anodic material in contact with a large cathodic material will result in greater corrosion. Likewise, a large anode in contact with a small cathode will decrease the rate of attack.

Chemical	Aluminum	Dura-Green	PVC	Type 304 Stainless	Type 316 Stainless	Zinc Coated Steel
Acetic Acid 10%	R	NR	R	R	R	NR
Acetic Acid 2%	R	F	R	R	R	NR
Acetone	R	R	NR	R	R	R
Ammonium Hydroxide-Conc.	R	R	R	R	R	-
Ammonium Hydroxide 10%	F	R	R	R	R	-
Ammonium Hydroxide 2%	R	R	R	R	R	-
Benzene	R	R	NR	R	R	-
Bromine Water	NR	R	R	NR	NR	-
Butanol (Butyl Alcohol)	R	R	R	R	R	R
Carbon Disulfide	R	R	NR	R	R	-
Carbon Tetrachloride	F	R	F	R	R	-
Chlorine Water	R	R	R	NR	F	R
Cutting Oil	-	R	-	-	-	-
Diethanolamine	R	R	NR	-	-	NR
Ethanol	R	R	R	R	R	R
Ethyl Acetate	R	R	NR	-	-	R
Ethylene Dichloride	F	R	NR	-	-	R
Formaldehyde 20%	R	R	R	R	R	R
Gasoline	R	R	R	R	R	R
Glycerine	R	R	R	R	R	R
Household Detergent 10%	F	R	R	R	R	-
Hydrochloric Acid 40%	NR	NR	R	NR	NR	NR
Hydrochloric Acid 10%	NR	F	-	NR	NR	NR
Hydrochloric Acid 2%	NR	F	-	NR	NR	NR
Hydrogen Peroxide 30%	R	NR	R	R	R	-
Hydrogen Peroxide 3%	R	R	-	R	R	-
Hydrogen Sulfide (Gas)	R	R	R	F	R	-
JP-4 Jet Fuel	R	R	R	R	R	-
Lactic Acid 85%	F	R	R	NR	-	-
Latex	R	R	-	R	R	NR
Linseed Oil Fatty Acid	R	F	R	R	R	-
Methanol	R	R	R	R	R	R
Methyl Ethyl Ketone	R	R	NR	-	-	R
Methyl Isobutyl Ketone	R	R	NR	-	-	R
Mineral Spirits	R	R	-	-	-	-
Motor Oil-10W	R	R	R	R	R	R
Naphtha, VM&P	R	R	R	R	R	R
Nitric Acid 2%	F	NR	R	R	R	-
Perchloroethylene	R	R	-	-	-	NR
Petroleum Ether	-	R	-	R	R	R
Phenol 10%	R	R	NR	R	R	R
Phosphoric Acid 2%	F	NR	R	R	R	NR
Potassium Hydroxide 50%	NR	R	R	R	R	-
Potassium Hydroxide 10%	NR	R	R	R	R	-
Potassium Hydroxide 2%	NR	R	R	R	R	-
Sodium Chloride 25%	F	R	R	R	R	F
Sodium Hydroxide 50%	NR	R	R	R	R	NR
Sodium Hydroxide 10%	NR	R	R	R	R	F
Sodium Hydroxide 2%	NR	R	R	-	-	-
Sodium Hypochlorite-C1. 10%	F	R	R	-	-	-
Sodium Hypochlorite-C1. 6%	F	R	R	NR	R	-
Sulfuric Acid 2%	F	NR	R	NR	R	NR
Tall Oil Fatty Acid (Syfate 94)	R	R	R	-	-	-
Tannic Acid 50%	F	R	R	R	R	-
Water-Deionized	R	R	R	R	R	F
Water-Sea	F	F	R	R	R	F
Water-Tap	R	R	R	F	F	R
Xyol	R	R	NR	-	-	-

Technical Data

Fiberglass corrosion chart on page 183.

The corrosion data given in this table is for general comparison only.

The presence of contaminants and the effect of temperature in chemical environments can greatly affect the corrosion of any material.

B-Line strongly suggests that field service tests or simulated laboratory tests using actual environmental conditions be conducted in order to determine the proper materials and finishes to be selected.

R=Recommended

F=May be used under some conditions

NR=Not Recommended

-Information not available

DESIGN OF STRUT SYSTEMS

Beams

Beams are usually defined as horizontal members which are subjected to vertical loads such as shelves, platforms or supports for pipes, conduits or cable trays. The following is a brief overview of common beam configurations:

Simple Beam

An example of a simple beam is a length of channel placed across two cylinders. When a load is applied, the channel will support the load because of its stiffness. The cylinders serve to support the channel, but do not interfere with its natural tendency to flex or bend. Simple beam analysis is used almost universally for beam comparisons, even though it is seldom practical in field installations.

A cable tray or conduit trapeze hanger closely resembles a simple beam.

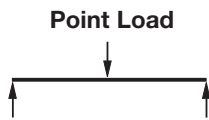

Fixed Beam

This type of fixed support restricts the movement of the ends of the channel when a load is applied. Because of this, the stiffness of the channel at the ends and center is employed to resist the load. The result is a load capability which is greater than that of an identical simple beam.

The fixed beam can be approximated by bolting or welding a length of channel to rigid supports.



Cantilever Beam

Cantilever beams are often viewed as variations of a fixed beam, but they have special characteristics of their own. One end of the channel is firmly attached to a rigid support while the other end remains completely free.

A shelf bracket is an example of a cantilever beam.



Continuous Beam

This beam configuration is commonly used in lighting installations. The continuous beam possesses traits of both the simple and fixed beams. When equal loads are applied to all spans simultaneously, the counter-balancing effect of the loads on both sides of a support restricts the movement of the channel at the support, similar to that of the fixed beam. The end spans behave substantially like simple beams.

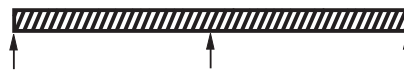

Continuous beam installations can typically support 20% more load than a simple beam of the same span with approximately half the deflection.

Therefore, simple beam data should be used for a general comparison only. An example of this configuration is found in a long run of channel when installed across several supports to form a number of spans.

Deflection

Deflection, commonly referred to as "sag", is inherent in applying a load to a beam and cannot be avoided. Any and all beams will deflect when loaded. The amount of deflection will vary depending upon the material and the stiffness or moment of inertia. The deflection equations in this section show that increasing the stiffness can be increased by a variety of methods. Increasing the depth of the channel is the most direct method.

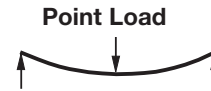

The material used affects deflection in a manner which is significantly different from the way in which it affects load capacity. The deflection under load is inversely proportional to a material property known as the "modulus of elasticity" designated by "E".

The modulus of elasticity is dependent upon the basic composition of the material and is not necessarily related to the material's strength.

Safety Factor

The design loads given for strut beam loads are based on a simple beam condition using allowable stress of 25,000 psi. This allowable stress results in a safety factor of 1.68. This is based upon a virgin steel minimum yield strength of 33,000 psi cold worked during rolling to an average yield stress of 42,000 psi.

Aluminum typically has an elastic modulus which is 1/3 that of steel even though they may have identical strength. As a result, the deflection of aluminum channel will be three times that of steel channel under equal loading. In areas where structures will be subject to general viewing, deflection can produce a displeasing effect. To the untrained eye, a sagging channel may appear to be a result of poor design or excessive loading. This is not usually the case. Many properly designed channel installations will show a noticeable deflection at their designed loads. In areas where cosmetics are not important, deflection should not be a factor. Designing an entire installation based on minimal deflection could result in an over designed structure. This translates into increased material and installation cost. Where cosmetics are important, it may be necessary to limit the deflection to an aesthetically pleasing amount. This "acceptable deflection" amount is typically given as a fraction of the span. **1/240 span** deflection is typically the limit where the amount of deflection appears negligible. For example, a beam span of 240" would be allowed 1" (240/240) of deflection at the mid point. A 120" span would only be allowed 1/2" (120/240) of deflection. The maximum load for the channel must be limited in order to remain under these deflection requirements. The allowable load resulting in 1/240 span deflection is posted in the beam load chart for each channel size.

For even more stringent deflection requirements, an allowable load is listed in the beam load charts which results in **1/360 span** deflection. This amount of deflection is sometimes used for beams in finished ceilings that are to be plastered.

Twisting & Lateral Bracing

Loading of strut on long spans can cause torsional stress, resulting in the tendency of the strut to twist or bend laterally. This phenomenon reduces the allowable beam loads as shown in the beam loading charts. It is recommended that long spans be supported in a manner to prevent twisting (fixed ends), and that the channel have adequate lateral bracing. Many typical strut applications provide this

support and bracing inherently. Piping, tubing, cable trays, or conduits mounted to the strut with straps and clamps prevent twisting or lateral movement. If no such lateral support exists, contact the factory for loading recommendations.

Columns

Columns are vertical members which carry loads in compression. One common example of a channel column is the vertical members of a storage rack.

In theory, a column will carry a load equal to its cross sectional area multiplied by the ultimate compressive stress of the material of which the column is made. In reality, there are many factors affecting the load capacity of a column, such as the tendency to buckle or twist laterally (torsional-flexural buckling), the type of connection at the top or bottom, the eccentricity of the load application, and material imperfections. Several of these failure modes have been considered in the allowable column load tables shown in the "Channel" section of this catalog.

B-Line strongly recommends that the engineer perform a detailed study of the many variable conditions before the selection process begins.

Design Factors to be Considered

The loading capacity of channel depends primarily on the material, its cross-sectional design, and the beam or column loading configuration. It should be noted that if two lengths of channel have identical designs and configurations, the one made of the stronger base material will support a larger load. Therefore, any comparison of channel should begin by determining whether the materials are approximately equal in strength.

The column loading chart for each channel lists the allowable load for each channel in compression. This load varies depending on the support condition or "K-factor".

Several "K-factors" are listed, which correspond to the following support conditions:

- K = .8 pinned top - fixed bottom
- K = .65 fixed top - fixed bottom
- K = 1.0 pinned top - pinned bottom
- K = 1.2 free top - fixed bottom

There are a number of physical properties which are important to the complete design of a channel member; the "section modulus" designated as "Sx" or "Sy", "moment of inertia" designated by "Ix" or "Iy", and the "radius of gyration" which is given as "rx" or "ry".

Every structural material has its own maximum or ultimate stress, which is usually expressed in "pounds per square inch" (pascals). Any load which causes a member to fail is referred to as its "ultimate" load. In order to prevent channel from being accidentally loaded up to or beyond its ultimate load, a safety factor is included into the design. The ultimate load is divided by the safety factor to obtain the "recommended" or "allowable" working load.

When evaluating channel under various beam conditions, it is often more convenient to compare in terms of the ultimate or recommended "bending moment". Simple equations show the stress is directly proportional to the bending moment.

Therefore, comparing bending moments can save time in repeated calculations. The chart containing Formulas on Common Beam Loadings (following page) shows how to calculate the bending moment for various configurations and load conditions. It should be noted that the bending moment is usually not constant, but varies along the length of the span. However, the channel must be designed for a single point, which is the point of maximum bending moment.

For information regarding dynamic or seismic design, contact us at: www.cooperbline.com/contactus.

GENERAL INFORMATION

Torque

The torque values given throughout the catalog are to be used as a guide only. The relationship between the applied torque or torque wrench reading and the actual tension created in the bolt may be substantially different. For example, a dry non-lubricated bolt with a heavy plating may rate 50% as efficient as a bolt which is lubricated with a mixture of heavy oil and graphite. Other important factors affecting torque-tension relationships include friction under the bolt head or nut, hole tolerances, and torque wrench tolerances. Accuracy of many commercial torque wrenches may vary as much as plus or minus 25%.









Charts and Tables

Charts and tables in this section are compiled from information published by nationally recognized organizations and are intended for use as a guide only. We recommend that users of this information determine the validity of such information as applied to their own application.

Technical Data

The data shown in the beam load charts for appropriate channels on page(s) 16 thru 37 is for simply supported, single span beams with a uniformly distributed load. For other loading and/or support conditions, use the appropriate factor from the chart below.

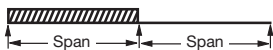
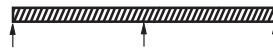
Technical Data

LOAD AND SUPPORT CONDITION	Load Factor	Deflection Factor
Simple Beam - Uniform Load 	1.00	1.00
Simple Beam - Concentrated Load at Center 	.50	.80
Simple Beam - Two Equal Concentrated Loads at 1/4 Points 	1.00	1.10
Beam Fixed at Both Ends - Uniform Load 	1.50	.30
Beam Fixed at Both Ends - Concentrated Load at Center 	1.00	.40
Cantilever Beam - Uniform Load 	.25	2.40
Cantilever Beam - Concentrated Load at End 	.12	3.20
Continuous Beam - Two Equal Spans - Uniform Load on One Span 	1.30	.92
Continuous Beam - Two Equal Spans - Concentrated Load on Both Spans 	1.00	.42
Continuous Beam - Two Equal Spans - Concentrated Load at Center of One Span 	.62	.71
Continuous Beam - Two Equal Spans - Concentrated Load at Center of Both Spans 	.67	.48

EXAMPLES:

PROBLEM:

Calculate the maximum allowable load and corresponding deflection of a simply supported B22 beam with a concentrated load at midspan as shown.



SOLUTION:

From beam load chart for B22 (page 22), maximum allowable Load is A and the corresponding deflection is B.
Multiplying by the appropriate factors shown in the chart above.

LOAD = A x load factor = _____
DEFLECTION = B x deflection factor = _____

PROBLEM:

Calculate the maximum allowable load and corresponding deflection of a cantilever B52 beam with a uniformly distributed load.



SOLUTION:

From beam load chart for B52 (page 33), maximum allowable load is A and the corresponding deflection is B.
Multiplying by the appropriate factors shown in chart above.

LOAD = A x load factor = _____
DEFLECTION = B x deflection factor = _____

RECOMMENDED BOLTED METAL FRAMING SPECIFICATION

Brackets [] indicate alternative specifications which may be substituted by the project engineer.

PART 1 - GENERAL

1.01 WORK INCLUDED

A. Continuous slot, bolted framing channels and all associated fittings and hardware.

B. Trapeze type supports for cable tray, conduit, pipe and other similar systems.

C. Use of bolted metal framing as a surface metal raceway.

1.02 REFERENCES

A. ASTM A108 - Specification for Steel Bars, Carbon, Cold Finished, Structural Quality.

B. ASTM A123 - Specification for Zinc (hot-dip galvanized) Coatings on Products Fabricated from Rolled, Pressed, and Forged Steel Shapes, Plates, Bars and Strips.

C. ASTM A1011, 33,000 PSI min. yield - Specification for Steel, Sheet and Strip, Carbon, Hot-Rolled, Structural Quality.

D. ASTM B633 - Specification for Electrodeposited Coatings of Zinc on Iron and Steel.

E. ASTM A653 33,000 PSI min. yield G90 - Specification for Steel Sheet, Zinc Coated (Galvanized) by the Hot-Dip Process, Structural Quality.

F. ASTM A1018 - Standard Specification for Steel, Sheet and Strip, Heavy-Thickness Coils, Carbon, Hot-Rolled, Structural Quality.

G. MFMA - Metal Framing Standards Publication, MFMA-4.

1.03 QUALITY ASSURANCE

A. Manufacturers: Firms regularly engaged in the manufacture of bolted metal framing of the types required, whose products have been in satisfactory use in similar service for not less than 5 years.

B. A material heat code number shall be stamped on all strut and fittings. This is required to maintain traceability of the product to the material test reports to the ASTM standard.

C. For stainless steel items, the part number shall contain a material designator (EXAMPLE: B-Line B22SS6 for type 316 or B22SS4 for type 304), or a separate stamp shall be included to reference the type of material used.

D. MFMA Compliance: comply with the latest revision of MFMA Standard Publication Number MFMA-4, "Metal Framing".

E. NEC Compliance: Comply with the latest revision NFPA 70 - Article 352 "Surface Metal Raceways and Surface Nonmetallic Raceways".

F. UL Compliance: Comply with UL "Standard for Surface Metal Raceway and Fittings".

1.04 SUBMITTALS

A. Submit drawings of strut and accessories including clamps, brackets, hanger rods and fittings.

B. Submit manufacturer's product data on strut channels including, but not limited to, types, materials, finishes, gauge thickness and hole patterns. For each different strut cross section, submit cross sectional properties including Section Modulus (S_x) and Moment of Inertia (I_x).

1.05 DELIVERY, STORAGE AND HANDLING

A. Deliver strut systems and components carefully to avoid breakage, denting, and scoring finishes. Do not install damaged equipment.

B. Store strut systems and components in original cartons and in clean dry space; protect from weather and construction traffic.

PART 2 - PRODUCTS

2.01 ACCEPTABLE MANUFACTURERS

A. Manufacturer: Subject to compliance with these specifications, strut systems to be installed shall be as manufactured by B-Line Systems, Inc. [or engineer approved equal.]

2.02 STRUT CHANNELS AND COMPONENTS

A. General: Strut shall be 1⁵/₈" wide in varying heights and welded combinations as required to meet load capacities and designs indicated on the drawings.

B. Material and Finish: Material and finish specifications for each strut type are as follows:

1. Aluminum: Strut shall be manufactured of extruded aluminum alloy 6063-T6. All fittings and hardware shall be zinc plated according to ASTM B633. For outdoor use, all fittings and hardware shall be stainless steel Type 316 [Type 304] or chromium zinc, ASTM F1136 Gr. 3.

2. Epoxy Painted: Strut shall be made from steel meeting the minimum mechanical properties of ASTM A1011 33,000 PSI min yield, then painted with water borne epoxy applied by a cathodic electro-deposition

process. Fittings shall be manufactured from steel meeting the minimum requirements of ASTM A1018 33,000 PSI min. yield. The fittings shall have the same epoxy finish as the strut. Threaded hardware shall be zinc plated in accordance with ASTM B633 Service Class 1 (SC1). Service Class 1 is not an acceptable coating for fittings or components other than threaded hardware.

3. Pre-Galvanized Steel: Strut shall be made from structural quality steel meeting the minimum mechanical properties of ASTM A653 33,000 PSI min. yield, mill galvanized coating designation G90. Fittings shall be manufactured from steel meeting the minimum requirements of ASTM A1018 33,000 PSI min. yield and zinc plated in accordance with ASTM B633 service class 3 (SC3). Threaded hardware shall be zinc plated in accordance with ASTM B633 Service Class 1 (SC1). Service Class 1 is not an acceptable coating for fittings or components other than threaded hardware.

4. Hot-Dip Galvanized Steel: Strut shall be made from structural quality steel meeting the minimum mechanical properties of ASTM A1011 33,000 PSI min. yield and shall be hot-dip galvanized after fabrication in accordance with ASTM A123. Fittings shall be manufactured from steel meeting the minimum requirements of ASTM A1018 33,000 PSI min. yield, and hot-dip galvanized after fabrication in accordance with ASTM A123. All hardware shall be stainless steel Type 316 [Type 304] or chromium zinc ASTM F1136 Gr. 3. All hot-dip galvanized after fabrication products must be returned to point of manufacture after coating for inspection and removal of all sharp burrs.

5. Stainless Steel: All strut, fittings and hardware shall be made of AISI Type 316 [Type 304] stainless steel as indicated. Channels must be identified as required in previous section 1.03 Quality Assurance.

PART 3 - EXECUTION

3.01 INSTALLATION

A. Install strut as indicated; in accordance with equipment manufacturer's recommendations, and with recognized industry practices.

B. All nuts and bolts shall be tightened to the following values.

Bolt Size	Torque (ft-lbs)
1/4-20	6
5/16-18	11
3/8-16	19
1/2-13	50

Metal Framing Channels

Channel

Metal framing channel is cold formed on our modern rolling mills from 12 Ga. (2.6mm), 14 Ga. (1.9mm), and 16 Ga. (1.5mm) low carbon steel strips. A continuous slot with turned lips provides the ability to make attachments at any point.

Lengths & Tolerances

All channels excluding 'SH' style
 $\pm 1/8"$ (3.2mm) on 10' (3.05m) and
 $\pm 3/16"$ (4.76mm) on 20' (6.09m)

All 'SH' channels only
 $\pm 1/4"$ (6.35mm) on 10' (3.05m) and
 $\pm 1/2"$ (12.70mm) on 20' (6.09m)

Custom lengths are available upon request.

Slots

Slotted series of channels offer full flexibility. A variety of pre-punched slot patterns eliminate the need for precise field measuring for hole locations. Slots offer wide adjustments in the alignment and bolt sizing.

Holes

A variety of pre-punched $9/16"$ (14.3 mm) diameter hole patterns are available in our channels. These hole patterns provide an economical alternative to costly field drilling required for many applications.

Knockouts

When used with series B217-20 Closure Strips, knockout channels can be used to provide an economical U.L. listed surface raceway. Channels are furnished with $7/8"$ (22.2 mm) knockouts on 6" (152 mm) centers, allowing for perfect fixture alignment on spans up to 20' (6.09 m).

Materials & Finishes (Unless otherwise noted)

Steel: Plain & Pre-galvanized

12 Ga. (2.6), 14 Ga. (1.9) and 16 Ga. (1.5)

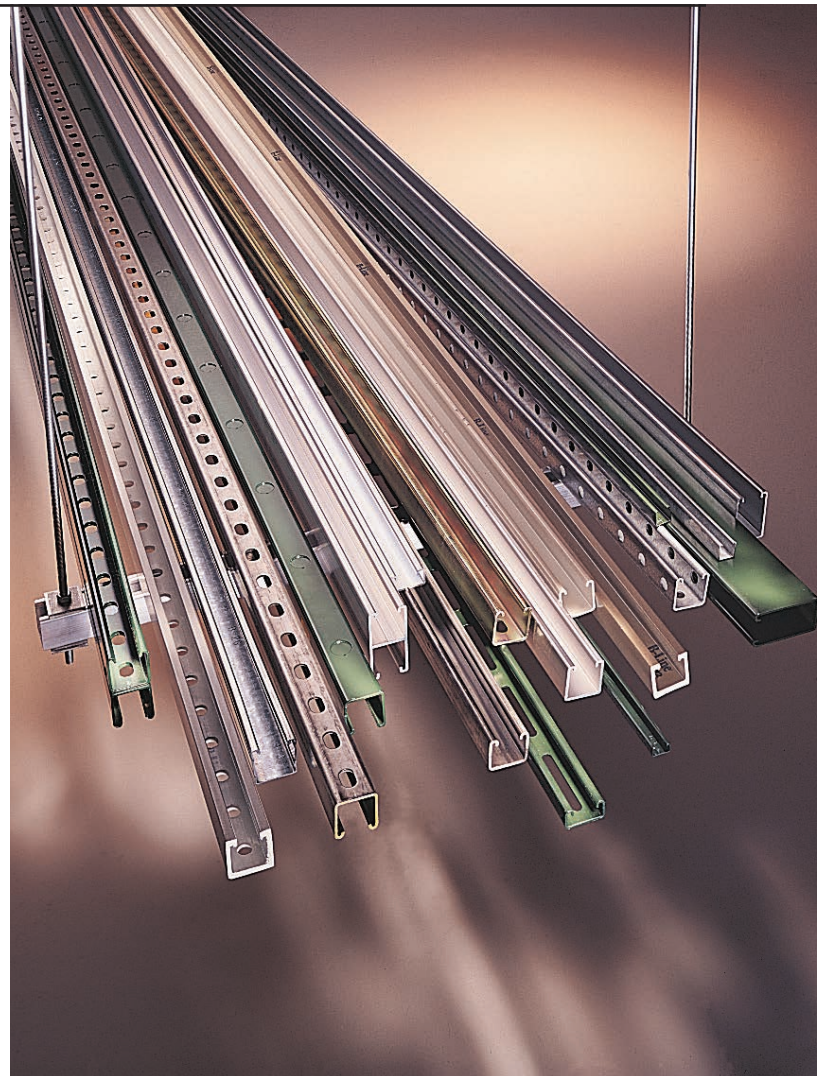

Channel & Combinations

Finish Code	Finish	Specification
PLN	Plain	ASTM A1011, 33,000 PSI min. yield
GRN	DURA-GREEN™	
GLV	Pre-Galvanized	ASTM A653 33,000 PSI min. yield
HDG	Hot-Dipped Galvanized	ASTM A123
YZN	Yellow Zinc Chromate	ASTM B633 SC3 Type II
SS4	Stainless Steel Type 304	ASTM A240
SS6	Stainless Steel Type 316	ASTM A240
AL	Aluminum	Aluminum 6063-T6

Note: A minimum order may apply on special material and finishes.

Design Load (Steel & Stainless Steel)

The design loads given for strut beam loads are based on a simple beam condition using an allowable stress of 25,000 psi. This allowable stress results in a safety factor of 1.68. This is based upon virgin steel minimum yield strength of 33,000 psi cold worked during rolling to an average yield stress of 42,000 psi. For aluminum channel loading multiply steel loading by a factor of 0.38.

Welding

Weld spacing is maintained between 2 $1/2$ inches (63.5 mm) and 4 inches (101.6 mm) on center. Through high quality control testing of welded channels and continuous monitoring of welding equipment, B-Line provides the most consistent combination channels available today.

Metric

Metric dimensions are shown in parentheses. Unless noted, all metric dimensions are in millimeters.

SELECTION CHART

for Channels, Materials and Hole Patterns

Channel Type	Channel Dimensions				Material & Thickness *				Channel Hole Pattern **				
	Height		Width		Steel	Alum.	Stainless Steel		SH 9/16" x 1 1/8" slots on 2" centers	S 13/32" x 3" slots	H17/8 9/16" diameter holes	TH 9/16" diameter on 1 7/8" centers	KO6 7/8" diameter knockouts
							Type 304	Type 316					
				<u>1</u>	<u>2</u>	<u>3</u>	<u>4</u>						
B11	3 1/4"	(82.5)	1 5/8"	(41.3)	12 Ga.	.105	-	-	<u>1</u>	<u>1</u>	<u>1</u>	-	<u>1</u>
B12	2 7/16"	(61.9)	1 5/8"	(41.3)	12 Ga.	.105	-	-	<u>1 2</u>	<u>1</u>	<u>1 2</u>	-	<u>1 2</u>
B22	1 5/8"	(41.3)	1 5/8"	(41.3)	12 Ga.	.105	12 Ga.	12 Ga.	<u>1 2 3 4</u>	<u>1 3</u>	<u>1 2 3</u>	<u>1</u>	<u>1 2</u>
B24	1 5/8"	(41.3)	1 5/8"	(41.3)	14 Ga.	.080	14 Ga.	14 Ga.	<u>1 2 3 4</u>	<u>1</u>	<u>1 2 3</u>	-	<u>1 2</u>
B26	1 5/8"	(41.3)	1 5/8"	(41.3)	16 Ga.	-	-	-	<u>1</u>	<u>1</u>	<u>1</u>	-	<u>1</u>
B32	1 3/8"	(34.9)	1 5/8"	(41.3)	12 Ga.	-	12 Ga.	-	<u>1 3</u>	<u>1</u>	<u>1 3</u>	-	<u>1</u>
B42	1"	(25.4)	1 5/8"	(41.3)	12 Ga.	-	12 Ga.	-	<u>1 3</u>	<u>1</u>	<u>1 3</u>	-	<u>1</u>
B52	1 3/16"	(20.6)	1 5/8"	(41.3)	12 Ga.	-	12 Ga.	12 Ga.	<u>1 3 4</u>	<u>1</u>	<u>1</u>	-	<u>1</u>
B54	1 3/16"	(20.6)	1 5/8"	(41.3)	14 Ga.	.080	14 Ga.	14 Ga.	<u>1 2 3 4</u>	<u>1</u>	<u>1 2 3 4</u>	-	<u>1 2</u>
B56	1 3/16"	(20.6)	1 5/8"	(41.3)	16 Ga.	-	-	-	<u>1</u>	<u>1</u>	<u>1</u>	-	<u>1</u>
B62	1 3/16"	(20.6)	1 3/16"	(20.6)	18 Ga.	-	-	-	-	-	-	-	-
B72	1 3/32"	(10.3)	1 3/16"	(20.6)	18 Ga.	-	-	-	-	-	-	-	-

The selection has been prepared to provide a reference for available channel, materials and hole patterns. Material types available for various hole patterns are defined by numbers 1 thru 4.
Some stainless steel channels with hole patterns are available on special order only.

*Metric equivalent for thicknesses shown in chart. **1 - Steel
 12 Ga. = 2.6 mm 18 Ga. = 1.2 mm 2 - Aluminum
 14 Ga. = 1.9 mm .105 = 2.6 mm 3 - Type 304 Stainless Steel
 16 Ga. = 1.5 mm .080 = 2.0 mm 4 - Type 316 Stainless Steel

Properties may vary due to commercial tolerances of the material.

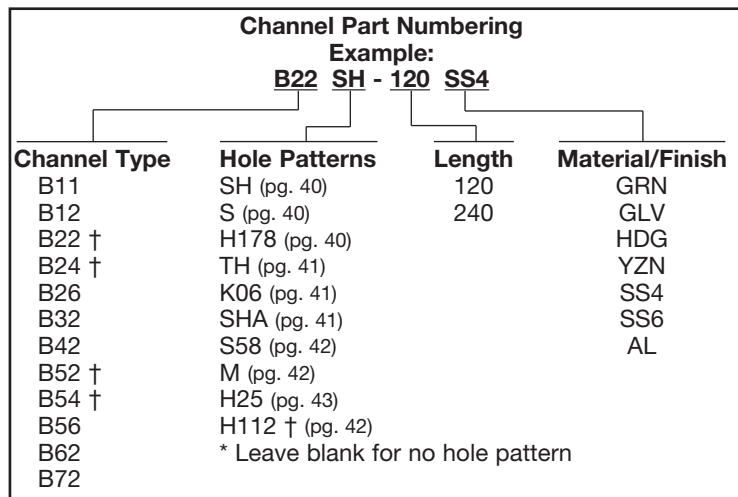

Reference page 14 for general fitting and standard finish specifications.

B11 Channel, Combinations & Load Data

B11

- Thickness: 12 Gauge (2.6 mm)
- Standard lengths: 10' (3.05 m) & 20' (6.09 m)
- Standard finishes: Plain, DURA-GREEN™, Pre-Galvanized, Hot-Dipped Galvanized, Aluminum
- Weight: 3.05 Lbs./Ft. (4.54 kg/m)

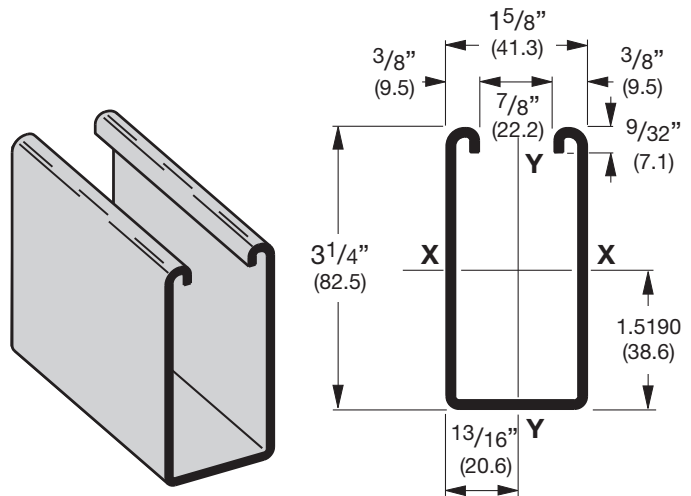

SECTION PROPERTIES

Channel	Weight		Areas of Section		Moment of Inertia (I)		X - X Axis		Radius of Gyration (r)		Moment of Inertia (I)		Section Modulus (S)		Radius of Gyration (r)	
							in. ⁴	cm ⁴	in.	cm	in. ⁴	cm ⁴	in. ³	cm ³	in.	cm
B11	3.059	(4.55)	.900	(5.81)	1.1203	(46.63)	.6472	(10.61)	1.116	(2.83)	.4357	(18.14)	.5362	(8.79)	.696	(1.77)
B11A	6.119	(9.11)	1.800	(11.61)	6.3931	(266.10)	1.9671	(32.24)	1.885	(4.79)	.8714	(36.27)	1.0725	(17.58)	.696	(1.77)

Calculations of section properties are based on metal thicknesses as determined by the AISI Cold-Formed Steel Design Manual.

BEAM LOADING

Beam Span		Channel Style	Uniform Load and Deflection				Uniform Load @ Deflection =					
In.	mm		Lbs.	kN	In.	mm	1/240 Span	1/360 Span	Lbs.	kN	Lbs.	kN
24	(609)	B11	5130	(22.82)	.029	(.73)	5130	(22.82)	5130	(22.82)	5130	(22.82)
		B11A	5130*	(22.82)	.005	(.13)	5130*	(22.82)	5130*	(22.82)	5130*	(22.82)
36	(914)	B11	3488	(15.51)	.065	(1.65)	3488	(15.51)	3488	(15.51)	3488	(15.51)
		B11A	5130*	(22.82)	.017	(.43)	5130*	(22.82)	5130*	(22.82)	5130*	(22.82)
48	(1219)	B11	2616	(11.63)	.117	(2.97)	2616	(11.63)	2616	(11.63)	2616	(11.63)
		B11A	5130*	(22.82)	.040	(1.01)	5130*	(22.82)	5130*	(22.82)	5130*	(22.82)
60	(1524)	B11	2093	(9.31)	.183	(4.65)	2093	(9.31)	1908	(8.49)	1908	(8.49)
		B11A	5130*	(22.82)	.079	(2.00)	5130*	(22.82)	5130*	(22.82)	5130*	(22.82)
72	(1829)	B11	1744	(7.76)	.263	(6.68)	1744	(7.76)	1325	(5.89)	1325	(5.89)
		B11A	5130*	(22.82)	.136	(3.45)	5130*	(22.82)	5130*	(22.82)	5130*	(22.82)
84	(2133)	B11	1495	(6.65)	.358	(9.09)	1460	(6.49)	974	(4.33)	974	(4.33)
		B11A	4552	(20.25)	.191	(4.85)	4552	(20.25)	4552	(20.25)	4552	(20.25)
96	(2438)	B11	1308	(5.82)	.468	(11.89)	1118	(4.97)	745	(3.31)	745	(3.31)
		B11A	3983	(17.72)	.250	(6.35)	3983	(17.72)	3983	(17.72)	3983	(17.72)
108	(2743)	B11	1163	(5.17)	.592	(15.03)	884	(3.93)	589	(2.62)	589	(2.62)
		B11A	3541	(15.75)	.317	(8.05)	3541	(15.75)	3353	(14.91)	3353	(14.91)
120	(3048)	B11	1046	(4.65)	.731	(18.57)	716	(3.18)	477	(2.12)	477	(2.12)
		B11A	3187	(14.17)	.391	(9.93)	3187	(14.17)	2716	(12.08)	2716	(12.08)
144	(3657)	B11	872	(3.88)	1.053	(26.74)	497	(2.21)	331	(1.47)	331	(1.47)
		B11A	2656	(11.81)	.563	(14.30)	2656	(11.81)	1886	(8.39)	1886	(8.39)
168	(4267)	B11	747	(3.32)	1.433	(36.40)	365	(1.62)	243	(1.08)	243	(1.08)
		B11A	2276	(10.12)	.766	(19.45)	2078	(9.24)	1386	(6.16)	1386	(6.16)
192	(4877)	B11	654	(2.91)	1.871	(47.52)	280	(1.24)	186	(0.83)	186	(0.83)
		B11A	1992	(8.86)	1.001	(25.42)	1591	(7.08)	1061	(4.72)	1061	(4.72)
216	(5486)	B11	581	(2.58)	2.368	(60.15)	221	(0.98)	147	(0.65)	147	(0.65)
		B11A	1770	(7.87)	1.267	(32.18)	1257	(5.59)	838	(3.73)	838	(3.73)
240	(6096)	B11	523	(2.32)	2.924	(74.27)	179	(0.79)	119	(0.53)	119	(0.53)
		B11A	1593	(7.08)	1.564	(39.72)	1018	(4.53)	679	(3.02)	679	(3.02)

Based on simple beam condition using an allowable design stress of 25,000 psi (172 MPa) in accordance with MFMA, with adequate lateral bracing (see page 11 for further explanation). Actual yield point of cold rolled steel is 42,000 psi (289 MPa). To determine concentrated load capacity at mid span, multiply uniform load by 0.5 and corresponding deflection by 0.8. *Failure determined by weld shear.

Reference page 14 for general fitting and standard finish specifications.

B11 Beam & Column Loading Data

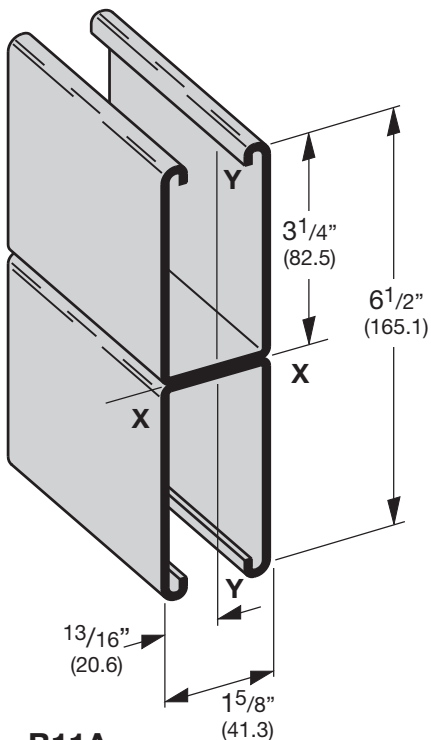

B11A
Wt. 6.10 Lbs./Ft. (9.08 kg/m)

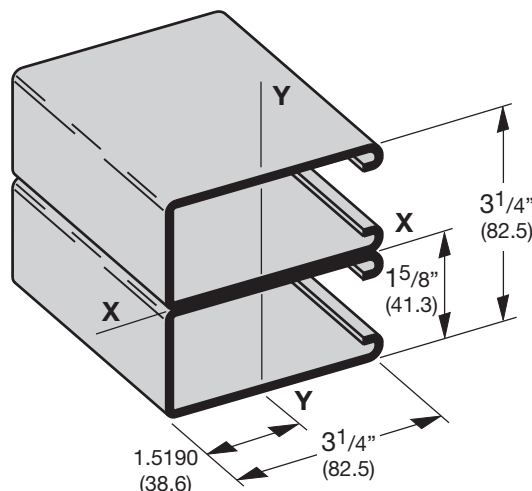

B11B
Wt. 6.10 Lbs./Ft. (9.08 kg/m)

COLUMN LOADING

Unbraced Height		Channel Style	Max. Column Loading K = .80				Max. Column Loading (Loaded @ C.G.)					
			Loaded@ C.G.		Loaded@ Slot Face		K = .65		K = 1.0		K = 1.2	
In.	mm		Lbs.	kN	Lbs.	kN	Lbs.	kN	Lbs.	kN	Lbs.	kN
24	(609)	B11	8190	(36.43)	4477	(19.91)	8446	(37.57)	7783	(34.62)	7311	(32.52)
		B11A	17701	(78.74)	8267	(36.77)	17778	(79.08)	17572	(78.16)	17416	(77.47)
36	(914)	B11	7311	(32.52)	4183	(18.61)	7838	(34.86)	6503	(28.93)	5612	(24.96)
		B11A	17416	(77.47)	8189	(36.42)	17590	(78.24)	17127	(76.18)	16774	(74.61)
48	(1219)	B11	6214	(27.64)	3783	(16.83)	7053	(31.37)	4988	(22.19)	3816	(16.97)
		B11A	17016	(75.69)	8079	(35.94)	17327	(77.07)	16503	(73.41)	15876	(70.62)
60	(1524)	B11	4988	(22.19)	3279	(14.58)	6140	(27.31)	3595	(15.99)	2790	(12.41)
		B11A	16503	(73.41)	7727	(34.37)	16988	(75.56)	15701	(69.84)	14721	(65.48)
72	(1829)	B11	3816	(16.97)	2444	(10.87)	5146	(22.89)	2790	(12.41)	2213	(9.84)
		B11A	15876	(70.62)	6160	(27.40)	16574	(73.72)	14721	(65.48)	13310	(59.20)
84	(2133)	B11	3063	(13.62)	1897	(8.44)	4133	(18.38)	2291	(10.19)	1846	(8.21)
		B11A	15135	(67.32)	4961	(22.07)	16084	(71.54)	13563	(60.33)	11642	(51.78)
96	(2438)	B11	2564	(11.40)	1532	(6.81)	3398	(15.11)	1953	(8.69)	1591	(7.08)
		B11A	14279	(63.51)	4045	(17.99)	15520	(69.03)	12226	(54.38)	9717	(43.22)
108	(2743)	B11	2213	(9.84)	1273	(5.66)	2886	(12.84)	1708	(7.60)	1401	(6.23)
		B11A	13310	(59.20)	3337	(14.84)	14880	(66.19)	10712	(47.65)	7725	(34.36)
120	(3048)	B11	1953	(8.69)	1081	(4.81)	2514	(11.18)	1522	(6.77)	1251**	(5.56)
		B11A	12226	(54.38)	2784	(12.38)	14164	(63.00)	9019	(40.12)	6257**	(27.83)
144	(3657)	B11	1591	(7.08)	816	(3.63)	2011	(8.94)	1251**	(5.56)	1026**	(4.56)
		B11A	9717	(43.22)	1990	(8.85)	12508	(55.64)	6257**	(27.83)	4345**	(19.33)
168	(4267)	B11	1347	(5.99)	642	(2.85)	1687	(7.50)	1058**	(4.70)	859**	(3.82)
		B11A	7183	(31.95)	1464	(6.51)	10550	(46.93)	4597**	(20.45)	3192**	(14.20)
192	(4877)	B11	1167**	(5.19)	519	(2.31)	1459	(6.49)	910**	(4.05)	-	-
		B11A	5499**	(24.46)	1121	(4.98)	8330	(37.05)	3520**	(15.66)	-	-
216	(5486)	B11	1026**	(4.56)	429	(1.91)	1285**	(5.71)	-	-	-	-
		B11A	4345**	(19.33)	885	(3.93)	6582**	(29.28)	-	-	-	-
240	(6096)	B11	910**	(4.05)	360	(1.60)	1148**	(5.10)	-	-	-	-
		B11A	3520**	(15.66)	717	(3.19)	5331**	(23.71)	-	-	-	-

**Where the slenderness ratio $\frac{KL}{r}$ exceeds 200, and K = end fixity factor, L = actual length and r = radius of gyration.

Reference page 14 for general fitting and standard finish specifications.

B12 Channel & Combinations

B12

- Thickness: 12 Gauge (2.6 mm)
- Standard lengths: 10' (3.05 m) & 20' (6.09 m)
- Standard finishes: Plain, DURA-GREEN™, Pre-Galvanized, Hot-Dipped Galvanized, Aluminum
- Weight: 2.47 Lbs./Ft. (3.67 kg/m)

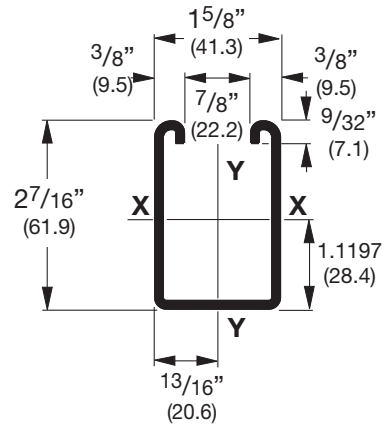
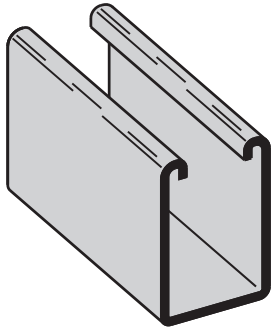

SECTION PROPERTIES

Channel	Weight		Areas of Section		Moment of Inertia (I)		Section Modulus (S)		Radius of Gyration (r)		Moment of Inertia (I)		Section Modulus (S)		Radius of Gyration (r)	
	lbs./ft.	kg/m	sq. in.	cm ²	in. ⁴	cm ⁴	in. ³	cm ³	in.	cm	in. ⁴	cm ⁴	in. ³	cm ³	in.	cm
B12	2.484	(3.70)	.731	(4.71)	.5349	(22.26)	.4061	(6.65)	.856	(2.17)	.3377	(14.06)	.4156	(6.81)	.680	(1.73)
B12A	4.969	(7.40)	1.462	(9.43)	2.9036	(120.86)	1.1915	(19.52)	1.409	(3.58)	.6756	(28.12)	.8315	(13.63)	.680	(1.73)

Calculations of section properties are based on metal thicknesses as determined by the AISI Cold-Formed Steel Design Manual.

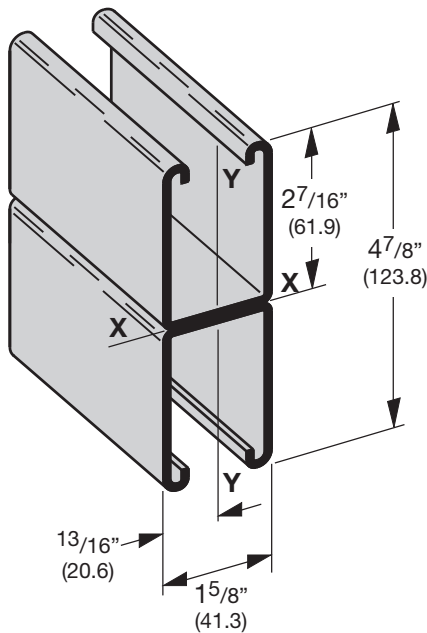

B12A
Wt. 4.94 Lbs./Ft. (7.35 kg/m)

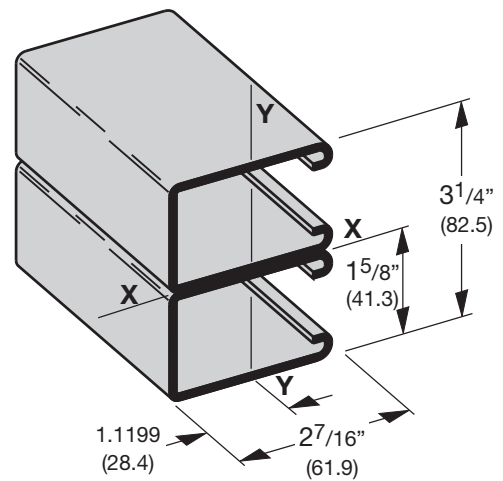

B12B
Wt. 4.94 Lbs./Ft. (7.35 kg/m)

Reference page 14 for general fitting and standard finish specifications.

B12 Beam & Column Loading Data

BEAM LOADING

Beam Span In. mm		Channel Style	Uniform Load and Deflection				Uniform Load @ Deflection =			
			1/240 Span		1/360 Span		1/240 Span		1/360 Span	
In.	mm		Lbs.	kN	In.	mm	Lbs.	kN	Lbs.	kN
12	(305)	B12	3880	(17.26)	.009	(.23)	3880	(17.26)	3880	(17.26)
		B12A	3880*	(17.26)	.001	(.02)	3880*	(17.26)	3880*	(17.26)
24	(609)	B12	3273	(14.56)	.038	(.96)	3273	(14.56)	3273	(14.56)
		B12A	3880*	(17.26)	.008	(.20)	3880*	(17.26)	3880*	(17.26)
36	(914)	B12	2182	(9.70)	.086	(2.18)	2182	(9.70)	2182	(9.70)
		B12A	3880*	(17.26)	.028	(.71)	3880*	(17.26)	3880*	(17.26)
48	(1219)	B12	1636	(7.28)	.153	(3.88)	1636	(7.28)	1421	(6.32)
		B12A	3880*	(17.26)	.067	(1.70)	3880*	(17.26)	3880*	(17.26)
60	(1524)	B12	1309	(5.82)	.240	(6.09)	1309	(5.82)	909	(4.04)
		B12A	3847*	(17.11)	.130	(3.30)	3847*	(17.11)	3847*	(17.11)
72	(1829)	B12	1091	(4.85)	.345	(8.76)	947	(4.21)	632	(2.81)
		B12A	3206	(14.26)	.188	(4.77)	3206	(14.26)	3206	(14.26)
84	(2133)	B12	935	(4.16)	.470	(11.94)	696	(3.09)	464	(2.06)
		B12A	2748	(12.22)	.255	(6.48)	2748	(12.22)	2509	(11.16)
96	(2438)	B12	818	(3.64)	.614	(15.59)	533	(2.37)	355	(1.58)
		B12A	2404	(10.69)	.334	(8.48)	2404	(10.69)	1921	(8.54)
108	(2743)	B12	727	(3.23)	.777	(19.73)	421	(1.87)	281	(1.25)
		B12A	2137	(9.50)	.422	(10.72)	2137	(9.50)	1518	(6.75)
120	(3048)	B12	655	(2.93)	.959	(24.36)	341	(1.52)	227	(1.01)
		B12A	1924	(8.56)	.521	(13.23)	1844	(8.20)	1229	(5.47)

Based on simple beam condition using an allowable design stress of 25,000 psi (172 MPa) in accordance with MFMA, with adequate lateral bracing (see page 11 for further explanation). Actual yield point of cold rolled steel is 42,000 psi. To determine concentrated load capacity at mid span, multiply uniform load by 0.5 and corresponding deflection by 0.8. *Failure determined by weld shear.

COLUMN LOADING

Unbraced Height In. mm		Channel Style	Max. Column Loading K = .80				Max. Column Loading (Loaded @ C.G.)					
			Loaded@ C.G.		Loaded@ Slot Face		K = .65		K = 1.0		K = 1.2	
In.	mm		Lbs.	kN	Lbs.	kN	Lbs.	kN	Lbs.	kN	Lbs.	kN
12	(305)	B12	10140	(45.10)	4752	(21.14)	10247	(45.58)	9965	(44.32)	9756	(43.40)
		B12A	20820	(92.61)	8023	(35.69)	20854	(92.76)	20763	(92.36)	20694	(92.05)
24	(609)	B12	9244	(41.12)	4514	(20.08)	9639	(42.87)	8629	(38.38)	7933	(35.29)
		B12A	20519	(91.27)	7956	(35.39)	20655	(91.88)	20293	(90.27)	20017	(89.04)
36	(914)	B12	7933	(35.29)	4137	(18.40)	8711	(35.75)	6786	(30.18)	5572	(24.78)
		B12A	20017	(89.04)	7844	(34.89)	20324	(90.40)	19509	(86.78)	18889	(84.02)
48	(1219)	B12	6386	(28.40)	3638	(16.18)	7562	(33.64)	4785	(21.28)	3717	(16.53)
		B12A	19315	(85.92)	7688	(34.20)	19861	(88.34)	18412	(81.90)	17309	(76.99)
60	(1524)	B12	4785	(21.28)	2963	(13.18)	6285	(27.96)	3523	(15.67)	2806	(12.48)
		B12A	18412	(81.90)	6941	(30.87)	19265	(85.69)	17002	(75.63)	15278	(67.96)
72	(1829)	B12	3717	(16.53)	2197	(9.77)	4964	(22.08)	2806	(12.48)	2271	(10.10)
		B12A	17309	(76.99)	5334	(23.73)	18536	(82.45)	15278	(67.96)	12795	(56.91)
84	(2133)	B12	3052	(13.57)	1717	(7.64)	3994	(17.76)	2345	(10.43)	1913	(8.51)
		B12A	16005	(71.19)	4176	(18.57)	17675	(78.62)	13240	(58.89)	9884	(43.96)
96	(2438)	B12	2600	(11.56)	1391	(6.19)	3350	(14.90)	2019	(8.98)	1650	(7.34)
		B12A	14500	(64.50)	3328	(14.80)	16682	(74.20)	10889	(48.43)	7567	(33.66)
108	(2743)	B12	2271	(10.10)	1155	(5.14)	2893	(12.87)	1773	(7.88)	1446	(6.43)
		B12A	12795	(56.91)	2692	(11.97)	15556	(69.19)	8610	(38.30)	5979	(26.59)
120	(3048)	B12	2019	(8.98)	977	(4.34)	2553	(11.35)	1577	(7.01)	1279**	(5.69)
		B12A	10889	(48.43)	2202	(9.79)	14298	(63.60)	6974	(31.02)	4843**	(21.54)

**Where the slenderness ratio $\frac{KL}{r}$ exceeds 200, and K = end fixity factor, L = actual length and r = radius of gyration.

Reference page 14 for general fitting and standard finish specifications.

B22 Channel

B22

- Thickness: 12 Gauge (2.6 mm)
- Standard lengths: 10' (3.05 m) & 20' (6.09 m)
- Standard finishes: Plain, DURA-GREEN™, Pre-Galvanized, Hot-Dipped Galvanized, Stainless Steel Type 304 or 316, Aluminum
- Weight: 1.90 Lbs./Ft. (2.83 kg/m)

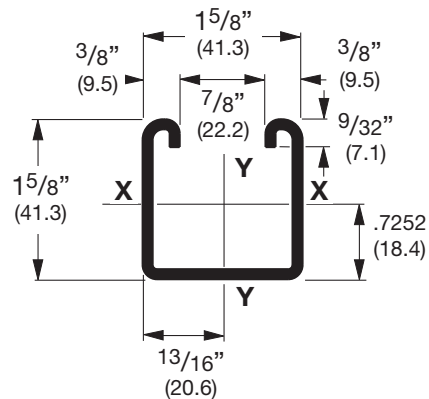
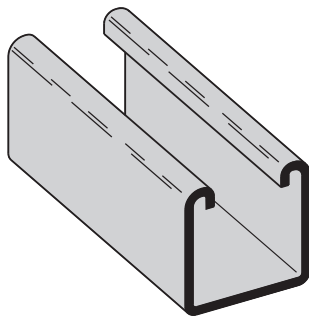

SECTION PROPERTIES

Channel	Weight lbs./ft. kg/m	Areas of Section		Moment of Inertia (I)		Section Modulus (S)		Radius of Gyration (r)		Moment of Inertia (I)		Section Modulus (S)		Radius of Gyration (r)	
		sq. in.	cm ²	in. ⁴	cm ⁴	in. ³	cm ³	in.	cm	in. ⁴	cm ⁴	in. ³	cm ³	in.	cm
B22	1.910 (2.84)	.562 (3.62)		.1912 (7.96)		.2125 (3.48)		.583 (1.48)		.2399 (9.99)		.2953 (4.84)		.653 (1.66)	
B22A	3.820 (5.69)	1.124 (7.25)		.9732 (40.51)		.5989 (9.81)		.931 (2.36)		.4798 (19.97)		.5905 (9.68)		.653 (1.66)	
B22X	6.649 (9.89)	1.956 (12.62)		4.1484 (172.67)		1.7019 (27.89)		1.456 (3.70)		1.1023 (45.88)		1.2027 (19.71)		.751 (1.91)	

Calculations of section properties are based on metal thicknesses as determined by the AISI Cold-Formed Steel Design Manual.

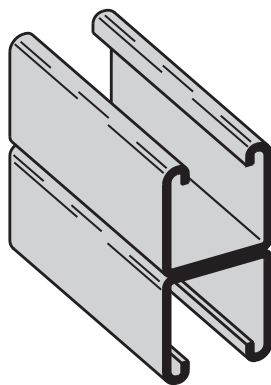

B22A

Wt. 3.80 Lbs./Ft. (5.65 kg/m)

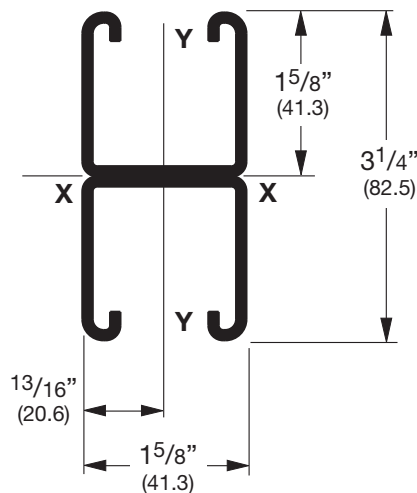

B22 Combinations

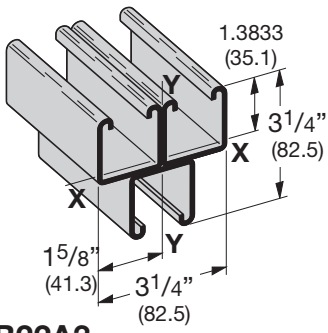

B22A3
Wt. 5.70 Lbs./Ft. (8.48 kg/m)

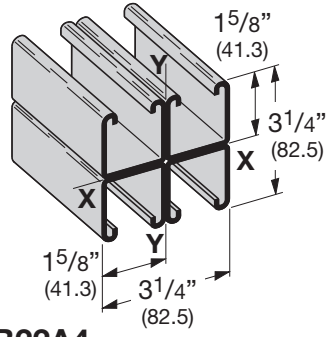

B22A4
Wt. 7.60 Lbs./Ft. (11.31 kg/m)

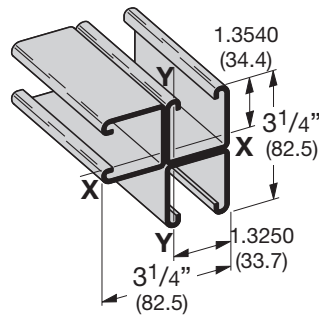

B22AD3
Wt. 5.70 Lbs./Ft. (8.48 kg/m)

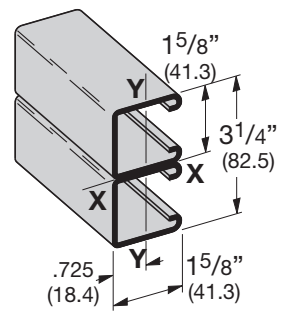

B22B
Wt. 3.80 Lbs./Ft. (5.65 kg/m)

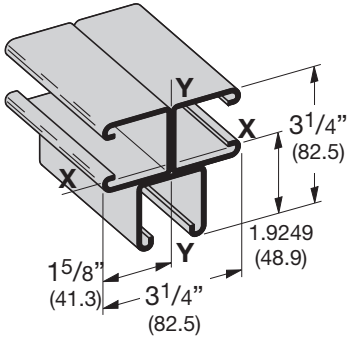

B22B3
Wt. 5.70 Lbs./Ft. (8.48 kg/m)

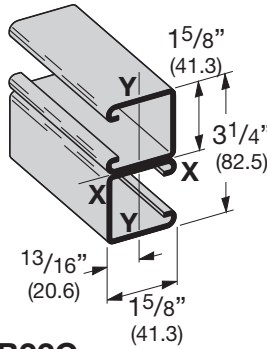

B22C
Wt. 3.80 Lbs./Ft. (5.65 kg/m)

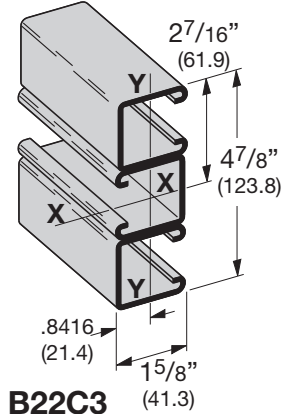

B22C3
Wt. 5.70 Lbs./Ft. (8.48 kg/m)

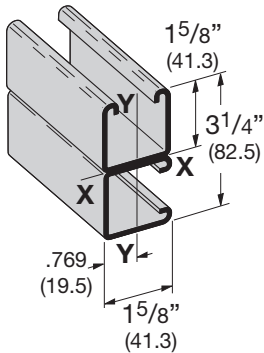

B22D
Wt. 3.80 Lbs./Ft. (5.65 kg/m)

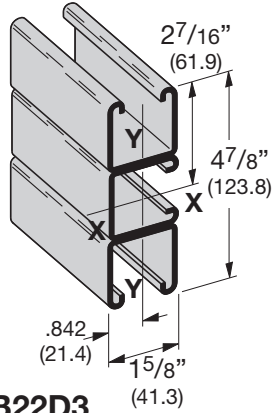

B22D3
Wt. 5.70 Lbs./Ft. (8.48 kg/m)

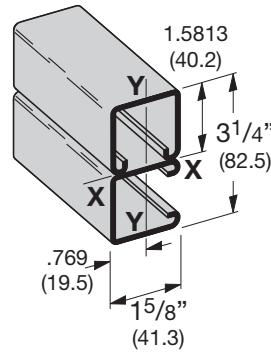

B22E
Wt. 3.80 Lbs./Ft. (5.65 kg/m)

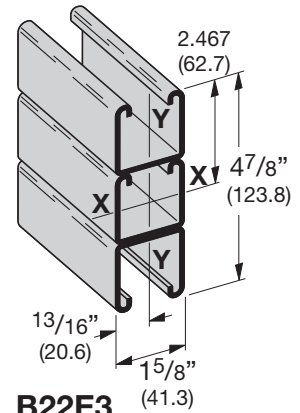

B22E3
Wt. 5.70 Lbs./Ft. (8.48 kg/m)

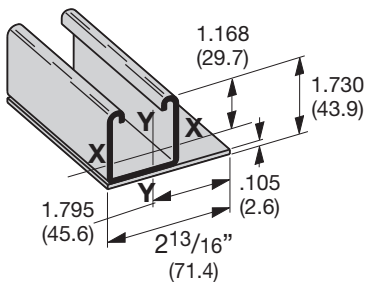

B22LPL
Wt. 2.90 Lbs./Ft. (4.31 kg/m)

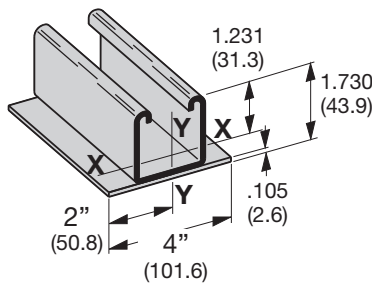

B22PL
Wt. 3.35 Lbs./Ft. (4.98 kg/m)

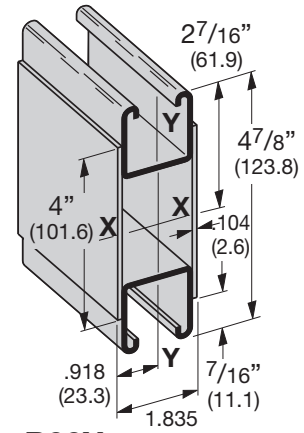

B22X
Wt. 6.70 Lbs./Ft. (9.97 kg/m)

Reference page 14 for general fitting and standard finish specifications.

B22 Beam Loading Data

Channel & Combinations

Beam Span In. mm		Channel Style	Uniform Load and Deflection				Uniform Load @ Deflection = 1/240 Span 1/360 Span			
			Lbs.	kN	In.	mm	Lbs.	kN	Lbs.	kN
12	(305)	B22	2610	(11.61)	.014	(.35)	2610	(11.61)	2610	(11.61)
		B22A	2610*	(11.61)	.002	(.05)	2610*	(11.61)	2610*	(11.61)
		B22X	5790*	(25.75)	.001	(.02)	5790*	(25.75)	5790*	(25.75)
18	(457)	B22	2269	(10.09)	.031	(.79)	2269	(10.09)	2269	(10.09)
		B22A	2610*	(11.61)	.007	(.18)	2610*	(11.61)	2610*	(11.61)
		B22X	5790*	(25.75)	.003	(.07)	5790*	(25.75)	5790*	(25.75)
24	(609)	B22	1702	(7.57)	.056	(1.42)	1702	(7.57)	1702	(7.57)
		B22A	2610*	(11.61)	.017	(.43)	2610*	(11.61)	2610*	(11.61)
		B22X	5790*	(25.75)	.008	(.20)	5790*	(25.75)	5790*	(25.75)
30	(762)	B22	1361	(6.05)	.087	(2.21)	1361	(6.05)	1294	(5.75)
		B22A	2610*	(11.61)	.033	(.84)	2610*	(11.61)	2610*	(11.61)
		B22X	5790*	(25.75)	.017	(.73)	5790*	(25.75)	5790*	(25.75)
36	(914)	B22	1135	(5.05)	.126	(3.20)	1135	(5.05)	899	(4.00)
		B22A	2610*	(11.61)	.057	(1.45)	2610*	(11.61)	2610*	(11.61)
		B22X	5790*	(25.75)	.029	(.73)	5790*	(25.75)	5790*	(25.75)
42	(1067)	B22	972	(4.32)	.172	(4.37)	972	(4.32)	660	(2.93)
		B22A	2610*	(11.61)	.091	(2.31)	2610*	(11.61)	2610*	(11.61)
		B22X	5790*	(25.75)	.046	(1.17)	5790*	(25.75)	5790*	(25.75)
48	(1219)	B22	851	(3.78)	.224	(5.69)	758	(3.37)	505	(2.24)
		B22A	2405	(10.70)	.125	(3.17)	2405	(10.70)	2405	(10.70)
		B22X	5790*	(25.75)	.068	(1.73)	5790*	(25.75)	5790*	(25.75)
54	(1371)	B22	756	(3.36)	.284	(7.21)	599	(2.66)	399	(1.77)
		B22A	2138	(9.51)	.158	(4.01)	2138	(9.51)	2024	(9.00)
		B22X	5790*	(25.75)	.097	(2.46)	5790*	(25.75)	5790*	(25.75)
60	(1524)	B22	681	(3.03)	.351	(8.91)	485	(2.16)	323	(1.44)
		B22A	1924	(8.56)	.195	(4.95)	1924	(8.56)	1640	(7.29)
		B22X	5645	(25.11)	.130	(3.30)	5645	(25.11)	5645	(25.11)
66	(1676)	B22	619	(2.75)	.424	(10.77)	401	(1.78)	267	(1.19)
		B22A	1749	(7.78)	.236	(5.99)	1749	(7.78)	1355	(6.03)
		B22X	5132	(22.83)	.158	(4.01)	5132	(22.83)	5132	(22.83)
72	(1829)	B22	567	(2.52)	.505	(12.83)	337	(1.50)	225	(1.00)
		B22A	1603	(7.13)	.281	(7.14)	1603	(7.13)	1139	(5.06)
		B22X	4704	(20.92)	.188	(4.77)	4704	(20.92)	4704	(20.92)
78	(1981)	B22	524	(2.33)	.593	(15.06)	287	(1.27)	191	(0.85)
		B22A	1480	(6.58)	.330	(8.38)	1455	(6.47)	970	(4.31)
		B22X	4342	(19.31)	.220	(5.59)	4342	(19.31)	4270	(18.99)
84	(2133)	B22	486	(2.16)	.687	(17.45)	248	(1.10)	165	(0.73)
		B22A	1374	(6.11)	.383	(9.73)	1255	(5.58)	837	(3.72)
		B22X	4032	(17.93)	.255	(6.48)	4032	(17.93)	3682	(16.38)
90	(2286)	B22	454	(2.02)	.789	(20.04)	216	(0.96)	144	(0.64)
		B22A	1283	(5.71)	.440	(11.17)	1093	(4.86)	729	(3.24)
		B22X	3763	(16.74)	.293	(7.44)	3763	(16.74)	3207	(14.26)
96	(2438)	B22	425	(1.89)	.898	(22.81)	190	(0.84)	126	(0.56)
		B22A	1202	(5.35)	.500	(12.70)	961	(4.27)	640	(2.85)
		B22X	3528	(15.69)	.334	(8.48)	3528	(15.69)	2819	(12.54)
102	(2591)	B22	400	(1.78)	1.013	(25.73)	168	(0.75)	112	(0.50)
		B22A	1132	(5.03)	.565	(14.35)	851	(3.78)	567	(2.52)
		B22X	3320	(14.77)	.377	(9.57)	3320	(14.77)	2497	(11.11)
108	(2743)	B22	378	(1.68)	1.136	(28.85)	150	(0.67)	100	(0.44)
		B22A	1069	(4.75)	.633	(16.08)	759	(3.37)	506	(2.25)
		B22X	3136	(13.95)	.422	(10.72)	3136	(13.95)	2227	(9.90)
114	(2895)	B22	358	(1.59)	1.266	(32.15)	134	(0.59)	90	(0.40)
		B22A	1013	(4.50)	.706	(17.93)	681	(3.03)	454	(2.02)
		B22X	2971	(13.21)	.471	(11.96)	2971	(13.21)	1999	(8.89)
120	(3048)	B22	340	(1.51)	1.403	(35.63)	121	(0.54)	81	(0.36)
		B22A	962	(4.28)	.782	(19.86)	615	(2.73)	410	(1.82)
		B22X	2822	(12.55)	.521	(13.23)	2706	(12.04)	1804	(8.02)

Based on simple beam condition using an allowable design stress of 25,000 psi (172 MPa) in accordance with MFMA, with adequate lateral bracing (see page 11 for further explanation). Actual yield point of cold rolled steel is 42,000 psi. To determine concentrated load capacity at mid span, multiply uniform load by 0.5 and corresponding deflection by 0.8. *Failure determined by weld shear.

Reference page 14 for general fitting and standard finish specifications.

B22 Column Loading Data

Unbraced Height		Channel Style	Max. Column Loading K = .80				Max. Column Loading (Loaded @ C.G.)					
			Loaded@ C.G.		Loaded@ Slot Face		K = .65		K = 1.0		K = 1.2	
			Lbs.	kN	Lbs.	kN	Lbs.	kN	Lbs.	kN	Lbs.	kN
In.	mm											
12	(305)	B22	10454	(46.50)	4276	(19.12)	10598	(47.14)	10222	(45.47)	9950	(44.26)
		B22A	21625	(96.19)	7002	(31.14)	21677	(96.42)	21539	(95.81)	21433	(95.34)
		B22X	46948	(208.83)	18975	(84.40)	47061	(209.34)	46761	(208.00)	46531	(206.98)
18	(457)	B22	9950	(44.26)	4153	(18.47)	10253	(45.62)	9481	(42.17)	8955	(39.83)
		B22A	21433	(95.34)	6959	(30.95)	21551	(95.86)	21239	(94.47)	21001	(93.42)
		B22X	46531	(206.98)	18859	(83.90)	46787	(208.12)	46110	(205.11)	45593	(202.81)
24	(609)	B22	9311	(41.42)	3993	(17.76)	9801	(43.60)	8582	(38.17)	7801	(34.70)
		B22A	21164	(94.14)	6898	(30.68)	21373	(95.07)	20819	(92.61)	20397	(90.73)
		B22X	45947	(204.38)	18693	(84.44)	46401	(206.40)	45198	(201.05)	44282	(196.97)
30	(762)	B22	8582	(38.17)	3802	(16.91)	9268	(41.22)	7601	(33.81)	6595	(29.33)
		B22A	20819	(92.61)	6821	(30.34)	21145	(94.06)	20279	(90.20)	19619	(87.27)
		B22X	45198	(201.05)	18485	(82.22)	45906	(204.20)	44026	(195.84)	42593	(189.46)
36	(914)	B22	7801	(34.70)	3589	(15.96)	8676	(38.59)	6595	(28.33)	5392	(23.98)
		B22A	20397	(90.73)	6728	(29.93)	20866	(92.81)	19619	(87.27)	18669	(83.04)
		B22X	44282	(196.97)	18233	(81.10)	45300	(201.50)	42593	(189.46)	40530	(180.28)
42	(1067)	B22	6998	(31.13)	3360	(14.94)	8048	(35.80)	5595	(24.89)	4444	(19.77)
		B22A	19898	(88.51)	6620	(29.45)	20537	(91.33)	18840	(83.80)	17546	(78.05)
		B22X	43198	(192.15)	17940	(79.80)	44586	(198.33)	40901	(181.94)	38092	(169.44)
48	(1219)	B22	6193	(27.55)	3118	(13.87)	7401	(32.92)	4718	(20.99)	3791	(16.86)
		B22A	19322	(85.95)	6496	(28.89)	20157	(89.66)	17940	(79.80)	16251	(72.29)
		B22X	41948	(186.59)	17604	(78.30)	43761	(194.57)	38948	(173.25)	35281	(156.94)
54	(1371)	B22	5392	(23.98)	2864	(12.74)	6746	(30.01)	4090	(18.19)	3310	(14.72)
		B22A	18669	(83.04)	6263	(27.86)	19276	(87.74)	16920	(75.26)	14782	(65.75)
		B22X	40530	(180.28)	16973	(75.50)	42825	(190.49)	36733	(163.39)	32092	(142.75)
60	(1524)	B22	4718	(20.99)	2631	(11.70)	6093	(27.10)	3616	(16.08)	2936	(13.06)
		B22A	17940	(79.80)	5340	(23.75)	19244	(85.60)	15781	(70.20)	13141	(58.45)
		B22X	38948	(173.25)	14471	(64.37)	41779	(185.84)	34260	(152.39)	28529	(126.90)
66	(1676)	B22	4202	(18.69)	2434	(10.83)	5441	(24.20)	3242	(14.42)	2634	(11.71)
		B22A	17134	(76.21)	4587	(20.40)	18712	(83.23)	14521	(64.59)	11328	(50.39)
		B22X	37198	(165.46)	12431	(55.29)	40624	(180.70)	31525	(140.23)	24593	(109.39)
72	(1829)	B22	3791	(16.86)	2264	(10.07)	4869	(21.66)	2936	(13.06)	2381	(10.59)
		B22A	16251	(72.29)	3968	(17.65)	18129	(80.64)	13141	(58.45)	9524	(42.36)
		B22X	35281	(156.94)	10753	(47.83)	39358	(175.07)	28529	(126.90)	20676	(91.97)
78	(1981)	B22	3456	(15.37)	2116	(9.41)	4412	(19.62)	2680	(11.92)	2166	(9.63)
		B22A	15291	(68.02)	3456	(15.37)	17496	(77.82)	11642	(51.78)	8115	(36.10)
		B22X	33197	(147.67)	9366	(41.66)	37984	(168.96)	25275	(112.43)	17617	(78.36)
84	(2133)	B22	3176	(14.13)	1984	(8.82)	4037	(17.96)	2461	(10.95)	1980	(8.81)
		B22A	14255	(63.41)	3028	(13.47)	16812	(74.78)	10076	(44.82)	6998	(31.13)
		B22X	30947	(137.66)	8206	(36.50)	36499	(162.35)	21875	(97.30)	15192	(67.58)
90	(2286)	B22	2936	(13.06)	1867	(8.30)	3724	(16.56)	2270	(10.10)	1816	(8.08)
		B22A	13141	(58.45)	2667	(11.86)	16077	(71.51)	8778	(39.04)	6096	(27.11)
		B22X	28529	(126.90)	7227	(32.15)	34903	(155.25)	19057	(84.77)	13234	(58.87)
96	(2438)	B22	2728	(16.58)	1761	(7.83)	3456	(15.37)	2101	(9.34)	1671	(7.43)
		B22A	11951	(53.16)	2359	(10.49)	15291	(68.02)	7715	(34.32)	5357	(23.83)
		B22X	25945	(115.41)	6393	(28.44)	33197	(147.67)	16749	(74.50)	11630	(51.73)
102	(2591)	B22	2545	(11.32)	1664	(7.40)	3225	(14.34)	1951	(8.68)	1542**	(6.34)
		B22A	10678	(47.50)	2093	(9.31)	14455	(64.30)	6834	(30.40)	4746	(21.11)
		B22X	23182	(103.12)	5672	(25.23)	31382	(139.59)	14836	(65.99)	10303	(45.83)
108	(2743)	B22	2381	(10.59)	1575	(7.00)	3022	(13.44)	1816	(8.08)	1426**	(68.60)
		B22A	9524	(42.36)	1867	(8.30)	13568	(60.35)	6096	(27.11)	4233	(18.83)
		B22X	20676	(91.97)	5059	(22.50)	29456	(131.03)	13234	(58.87)	9190	(40.88)
114	(2895)	B22	2234	(9.94)	1494	(6.64)	2842	(12.64)	1694	(7.53)	1322**	(5.88)
		B22A	8548	(38.02)	1675	(7.45)	12630	(56.18)	5471	(24.33)	3799**	(16.90)
		B22X	18558	(82.55)	4539	(20.19)	27420	(121.97)	11877	(52.83)	8247	(36.68)
120	(3048)	B22	2101	(9.34)	1418	(6.31)	2680	(11.92)	1583**	(7.04)	1228**	(5.46)
		B22A	7715	(34.32)	1512	(6.72)	11642	(51.78)	4937	(21.96)	3429**	(15.25)
		B22X	16749	(74.50)	4097	(18.22)	25275	(112.43)	10718	(47.67)	7444	(33.11)

**Where the slenderness ratio $\frac{KL}{r}$ exceeds 200, and K = end fixity factor, L = actual length and r = radius of gyration.

Reference page 14 for general fitting and standard finish specifications.

B24 Channel & Combinations

B24

- Thickness: 14 Gauge (1.9 mm)
- Standard lengths: 10' (3.05 m) & 20' (6.09 m)
- Standard finishes: Plain, DURA-GREEN™, Pre-Galvanized, Hot-Dipped Galvanized, Stainless Steel Type 304 or 316, Aluminum
- Weight: 1.40 Lbs./Ft. (2.08 kg/m)

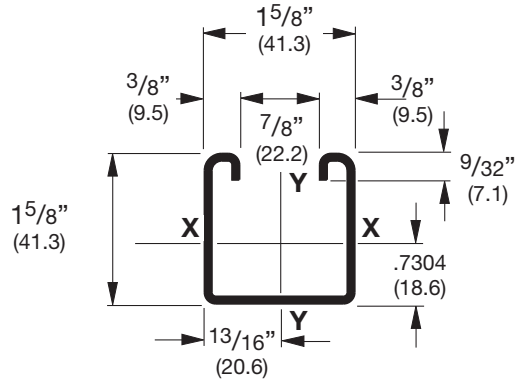
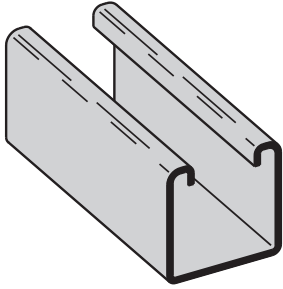

SECTION PROPERTIES

Channel	Weight lbs./ft. kg/m	Areas of Section		Moment of Inertia (I)		Section Modulus (S)		Radius of Gyration (r)		Moment of Inertia (I)		Section Modulus (S)		Radius of Gyration (r)	
		sq. in.	cm ²	in. ⁴	cm ⁴	in. ³	cm ³	in.	cm	in. ⁴	cm ⁴	in. ³	cm ³	in.	cm
B24	1.442 (2.15)	.424 (2.74)		.1494 (6.22)		.1670 (2.74)		.594 (1.51)		.1857 (7.73)		.2286 (3.75)		.662 (1.68)	
B24A	2.884 (4.29)	.848 (5.47)		.7514 (31.28)		.4624 (7.58)		.941 (2.39)		.3713 (15.45)		.4570 (7.49)		.662 (1.68)	

Calculations of section properties are based on metal thicknesses as determined by the AISI Cold-Formed Steel Design Manual.

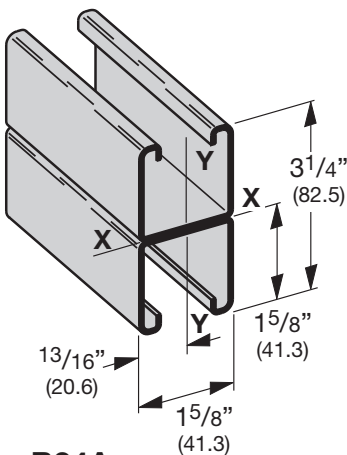

B24A
Wt. 2.80 Lbs./Ft. (4.16 kg/m)

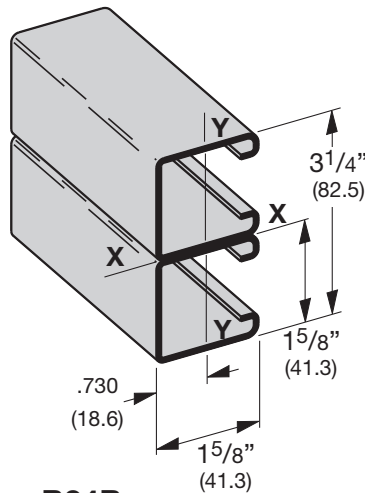

B24B
Wt. 2.80 Lbs./Ft. (4.16 kg/m)

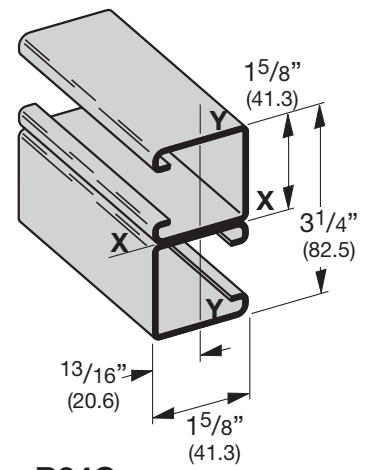

B24C
Wt. 2.80 Lbs./Ft. (4.16 kg/m)

Reference page 14 for general fitting and standard finish specifications.

B24 Beam & Column Loading Data

BEAM LOADING

Beam Span In. mm		Channel Style	Uniform Load and Deflection				Uniform Load @ Deflection =			
			Lbs. kN		In. mm		1/240 Span		1/360 Span	
			Lbs.	kN	In.	mm	Lbs.	kN	Lbs.	kN
12	(305)	B24	1750	(7.78)	.014	(.35)	1750	(7.78)	1750	(7.78)
		B24A	1750*	(7.78)	.002	(.05)	1750*	(7.78)	1750*	(7.78)
24	(609)	B24	1379	(6.13)	.057	(1.45)	1379	(6.13)	1379	(6.13)
		B24A	1750*	(7.78)	.014	(.35)	1750*	(7.78)	1750*	(7.78)
36	(914)	B24	919	(4.09)	.128	(3.25)	919	(4.09)	720	(3.20)
		B24A	1750*	(7.78)	.048	(1.22)	1750*	(7.78)	1750*	(7.78)
48	(1219)	B24	689	(3.06)	.227	(5.76)	607	(2.70)	405	(1.80)
		B24A	1750*	(7.78)	.115	(2.92)	1750*	(7.78)	1750*	(7.78)
60	(1524)	B24	551	(2.45)	.355	(9.02)	389	(1.73)	259	(1.15)
		B24A	1518	(6.75)	.195	(4.95)	1518	(6.75)	1294	(5.75)
72	(1829)	B24	460	(2.04)	.511	(12.98)	270	(1.20)	180	(0.80)
		B24A	1265	(5.63)	.281	(7.14)	1265	(5.63)	898	(3.99)
84	(2133)	B24	394	(1.75)	.695	(17.65)	198	(0.88)	132	(0.59)
		B24A	1084	(4.82)	.383	(9.73)	990	(4.40)	660	(2.93)
96	(2438)	B24	345	(1.53)	.908	(23.06)	152	(0.67)	101	(0.45)
		B24A	949	(4.22)	.500	(12.70)	758	(3.37)	505	(2.24)
108	(2743)	B24	306	(1.36)	1.149	(29.18)	120	(0.53)	80	(0.35)
		B24A	843	(3.75)	.633	(16.08)	599	(2.66)	399	(1.77)
120	(3048)	B24	276	(1.23)	1.419	(36.04)	97	(0.43)	65	(0.29)
		B24A	759	(3.37)	.782	(19.86)	485	(2.16)	323	(1.44)

Based on simple beam condition using an allowable design stress of 25,000 psi (172 MPa) in accordance with MFMA, with adequate lateral bracing (see page 11 for further explanation). Actual yield point of cold rolled steel is 42,000 psi. To determine concentrated load capacity at mid span, multiply uniform load by 0.5 and corresponding deflection by 0.8. *Failure determined by weld shear.

COLUMN LOADING

Unbraced Height In. mm		Channel Style	Max. Column Loading K = .80				Max. Column Loading (Loaded @ C.G.)					
			Loaded@ C.G.		Loaded@ Slot Face		K = .65		K = 1.0		K = 1.2	
			Lbs.	kN	Lbs.	kN	Lbs.	kN	Lbs.	kN	Lbs.	kN
12	(305)	B24	6441	(28.65)	3077	(13.69)	6509	(28.95)	6330	(28.16)	6198	(27.57)
		B24A	13212	(58.77)	4988	(22.19)	13237	(58.88)	13171	(58.59)	13121	(58.36)
24	(609)	B24	5874	(26.13)	2896	(12.88)	6124	(27.24)	5483	(24.39)	5038	(22.41)
		B24A	12993	(57.79)	4924	(21.90)	13092	(58.23)	12828	(57.06)	12627	(56.17)
36	(914)	B24	5038	(22.41)	2619	(11.65)	5535	(24.62)	4302	(19.13)	3516	(15.64)
		B24A	12627	(56.17)	4819	(21.43)	12851	(57.16)	12256	(54.52)	11804	(52.51)
48	(1219)	B24	4043	(17.98)	2272	(10.10)	4800	(21.35)	3008	(13.38)	2324	(10.34)
		B24A	12115	(53.89)	4675	(20.79)	12512	(55.65)	11456	(50.96)	10651	(47.38)
60	(1524)	B24	3008	(13.38)	1873	(8.33)	3978	(17.69)	2200	(9.78)	1740	(7.74)
		B24A	11456	(50.96)	4020	(17.88)	12078	(53.72)	10427	(46.38)	9169	(40.78)
72	(1829)	B24	2324	(10.34)	1562	(6.95)	3123	(13.89)	1740	(7.74)	1397	(6.21)
		B24A	10651	(47.38)	3048	(13.56)	11546	(51.36)	9169	(40.78)	7358	(32.73)
84	(2133)	B24	1898	(8.44)	1340	(5.96)	2502	(11.13)	1444	(6.42)	1168	(5.19)
		B24A	9700	(43.15)	2362	(10.50)	10918	(48.56)	7683	(34.17)	5464	(24.30)
96	(2438)	B24	1608	(7.15)	1175	(5.22)	2089	(9.29)	1236	(5.50)	1000	(4.45)
		B24A	8602	(38.26)	1866	(8.30)	10194	(45.34)	6024	(26.79)	4184	(18.61)
108	(2743)	B24	1397	(6.21)	1046	(4.65)	1796	(7.99)	1078	(4.79)	870**	(3.87)
		B24A	7358	(32.73)	1498	(6.66)	9373	(41.69)	4760	(21.17)	3306	(14.70)
120	(3048)	B24	1236	(5.50)	942	(4.19)	1578	(7.02)	953**	(4.24)	764**	(3.40)
		B24A	6024	(26.79)	1216	(5.41)	8455	(37.61)	3856	(17.15)	2677**	(11.91)

**Where the slenderness ratio $\frac{KL}{r}$ exceeds 200, and K = end fixity factor, L = actual length and r = radius of gyration.

Reference page 14 for general fitting and standard finish specifications.

B26 Channel & Combinations

B26

- Thickness: 16 Gauge (1.5 mm)
- Standard lengths: 10' (3.05 m) & 20' (6.09 m)
- Standard finishes: Plain, DURA-GREEN™, Pre-Galvanized
- Weight: 1.12 Lbs./Ft. (1.66 kg/m)

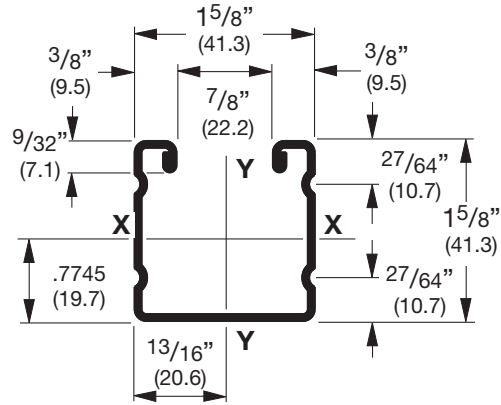
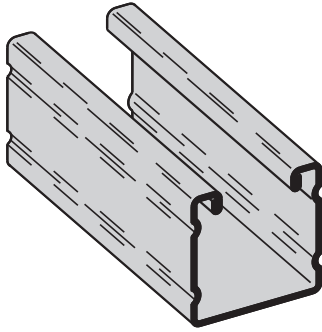

SECTION PROPERTIES

Channel	Weight lbs./ft. kg/m	Areas of Section		Moment of Inertia (I)		Section Modulus (S)		Radius of Gyration (r)		Moment of Inertia (I)		Section Modulus (S)		Radius of Gyration (r)	
		sq. in.	cm ²	in. ⁴	cm ⁴	in. ³	cm ³	in.	cm	in. ⁴	cm ⁴	in. ³	cm ³	in.	cm
B26	1.234 (1.84)	.363	(2.34)	.1337	(5.57)	.1581	(2.59)	.607	(1.54)	.1564	(6.51)	.1925	(3.15)	.656	(1.67)
B26A	2.467 (3.67)	.726	(4.68)	.7086	(29.49)	.4361	(7.15)	.988	(2.51)	.3128	(13.02)	.3850	(6.31)	.656	(1.67)

Calculations of section properties are based on metal thicknesses as determined by the AISI Cold-Formed Steel Design Manual.

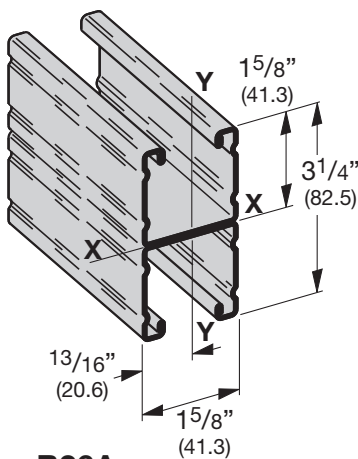

B26A

Wt. 2.24 Lbs./Ft. (3.33 kg/m)

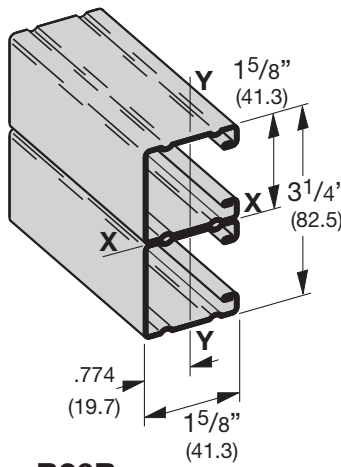

B26B

Wt. 2.24 Lbs./Ft. (3.33 kg/m)

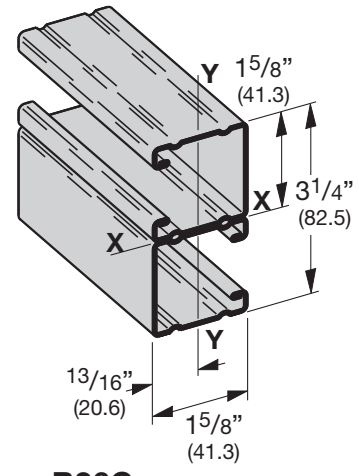

B26C

Wt. 2.24 Lbs./Ft. (3.33 kg/m)

Reference page 14 for general fitting and standard finish specifications.

B26 Beam & Column Loading Data

BEAM LOADING

Beam Span In. mm		Channel Style	Uniform Load and Deflection				Uniform Load @ Deflection =			
			Lbs. kN		In. mm		1/240 Span		1/360 Span	
			Lbs.	kN	In.	mm	Lbs.	kN	Lbs.	kN
12	(305)	B26	1220	(5.43)	.014	(.35)	1220	(5,43)	1220	(5.43)
		B26A	1220*	(5.43)	.001	(.02)	1220*	(5,43)	1220*	(5.43)
24	(609)	B26	1163	(5.17)	.057	(1.45)	1163	(5,17)	1163	(5.17)
		B26A	1220*	(5.43)	.012	(.30)	1220*	(5,43)	1220*	(5.43)
36	(914)	B26	775	(3.45)	.128	(3.25)	775	(3,45)	603	(2.68)
		B26A	1220*	(5.43)	.040	(1.01)	1220*	(5,43)	1220*	(5.43)
48	(1219)	B26	581	(2.58)	.228	(5.79)	509	(2,264)	339	(1.51)
		B26A	1220*	(5.43)	.096	(2.44)	1220*	(5,43)	1220*	(5.43)
60	(1524)	B26	465	(2.07)	.357	(9.07)	326	(1,45)	217	(0.96)
		B26A	1220*	(5.43)	.188	(4.77)	1220*	(5,43)	1076	(4.78)
72	(1829)	B26	388	(1.72)	.514	(13.05)	226	(1,45)	151	(0.96)
		B26A	1052	(4.68)	.281	(7.14)	1052	(4,68)	747	(3.32)
84	(2133)	B26	332	(1.48)	.699	(17.75)	166	(0,74)	111	(0.49)
		B26A	902	(4.01)	.383	(9.73)	824	(3,66)	549	(2.44)
96	(2438)	B26	291	(1.29)	.913	(23.19)	127	(0,56)	85	(0.38)
		B26A	789	(3.51)	.500	(12.70)	631	(2,81)	420	(1.87)
108	(2743)	B26	258	(1.15)	1.156	(29.36)	101	(0,45)	67	(0.30)
		B26A	702	(3.12)	.633	(16.08)	498	(2,21)	332	(1.48)
120	(3048)	B26	233	(1.03)	1.427	(36.24)	81	(0,36)	54	(0.24)
		B26A	631	(2.17)	.782	(19.86)	404	(1,80)	269	(1.19)

Based on simple beam condition using an allowable design stress of 25,000 psi (172 MPa) in accordance with MFMA, with adequate lateral bracing (see page 11 for further explanation). Actual yield point of cold rolled steel is 42,000 psi. To determine concentrated load capacity at mid span, multiply uniform load by 0.5 and corresponding deflection by 0.8. *Failure determined by weld shear.

COLUMN LOADING

Unbraced Height In. mm		Channel Style	Max. Column Loading K = .80				Max. Column Loading (Loaded @ C.G.)					
			Loaded@ C.G.		Loaded@ Slot Face		K = .65		K = 1.0		K = 1.2	
			Lbs.	kN	Lbs.	kN	Lbs.	kN	Lbs.	kN	Lbs.	kN
12	(305)	B26	4002	(17.80)	2216	(9.86)	4032	(17.93)	3952	(17.58)	3891	(17.31)
		B26A	8151	(36.26)	3630	(16.15)	8163	(36.31)	8133	(36.18)	8109	(36.07)
24	(609)	B26	3740	(16.63)	2109	(9.38)	3857	(17.16)	3554	(15.81)	3336	(14.84)
		B26A	8051	(35.81)	3591	(15.97)	8096	(36.01)	7975	(35.47)	7883	(35.06)
36	(914)	B26	3336	(14.49)	1941	(8.63)	3579	(15.92)	2962	(13.17)	2546	(11.32)
		B26A	7883	(35.06)	3528	(15.69)	7986	(35.52)	7713	(34.31)	7505	(33.38)
48	(1219)	B26	2828	(12.58)	1725	(7.61)	3217	(14.31)	2251	(10.01)	1705	(7.58)
		B26A	7648	(34.02)	3441	(15.30)	7831	(34.83)	7346	(32.67)	6977	(31.03)
60	(1524)	B26	2251	(10.01)	1469	(6.53)	2793	(12.42)	1603	(7.13)	1233	(5.48)
		B26A	7346	(32.67)	3066	(13.64)	7631	(33.94)	6874	(30.58)	6298	(28.01)
72	(1829)	B26	1705	(7.58)	1203	(5.35)	2326	(10.34)	1233	(5.48)	967	(4.30)
		B26A	6977	(31.03)	2385	(10.61)	7388	(32.86)	6298	(28.01)	5467	(24.32)
84	(2133)	B26	1358	(6.04)	1011	(4.50)	1851	(8.23)	1003	(4.46)	797	(3.54)
		B26A	6541	(29.09)	1884	(8.38)	7100	(31.58)	5616	(24.98)	4486	(19.95)
96	(2438)	B26	1129	(5.02)	871	(3.87)	1513	(6.73)	847	(3.77)	680	(3.02)
		B26A	6038	(26.86)	1512	(6.72)	6767	(30.10)	4830	(21.48)	3463	(15.40)
108	(2743)	B26	967	(4.30)	766	(3.41)	1277	(5.68)	734	(3.26)	592**	(2.63)
		B26A	5467	(24.32)	1231	(5.47)	6391	(28.43)	3940	(17.52)	2736	(12.17)
120	(3048)	B26	847	(3.77)	684	(3.04)	1105	(4.91)	648	(2.88)	523**	(2.32)
		B26A	4830	(21.48)	1015	(4.51)	5970	(26.55)	3192	(14.20)	2216**	(9.86)

**Where the slenderness ratio $\frac{KL}{r}$ exceeds 200, and K = end fixity factor, L = actual length and r = radius of gyration.

Reference page 14 for general fitting and standard finish specifications.

B32 Channel & Combinations

B32

- Thickness: 12 Gauge (2.6 mm)
- Standard lengths: 10' (3.05 m) & 20' (6.09 m)
- Standard finishes: Plain, DURA-GREEN™, Pre-Galvanized, Hot-Dipped Galvanized, Stainless Steel Type 304
- Weight: 1.70 Lbs./Ft. (2.53 kg/m)

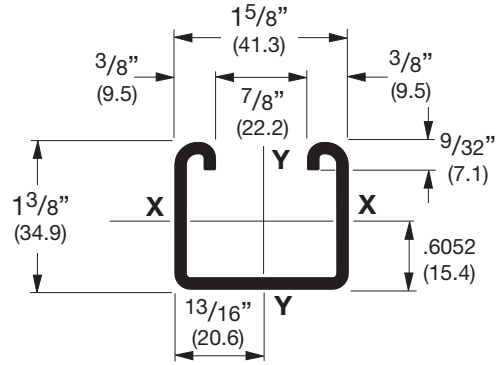
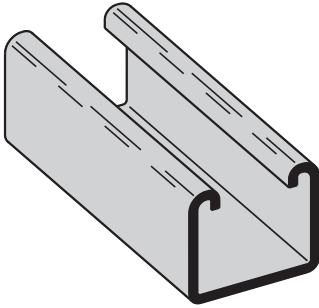

SECTION PROPERTIES

Channel	Weight		Areas of Section		Moment of Inertia (I)		Section Modulus (S)		X - X Axis		Moment of Inertia (I)		Y - Y Axis		Section Modulus (S)		Radius of Gyration (r)	
									Radius of Gyration (r)				Radius of Gyration (r)					
	lbs./ft.	kg/m	sq. in.	cm ²	in. ⁴	cm ⁴	in. ³	cm ³	in.	cm	in. ⁴	cm ⁴	in. ³	cm ³	in.	cm	in.	cm
B32	1.733	(2.58)	.510	(3.29)	.1252	(5.21)	.1626	(2.67)	.496	(1.26)	.2098	(8.73)	.2582	(4.23)	.642	(1.63)		
B32A	3.467	(5.16)	1.020	(6.58)	.6238	(25.96)	.4537	(7.43)	.782	(1.99)	.4195	(17.46)	.5163	(8.46)	.642	(1.63)		

Calculations of section properties are based on metal thicknesses as determined by the AISI Cold-Formed Steel Design Manual.

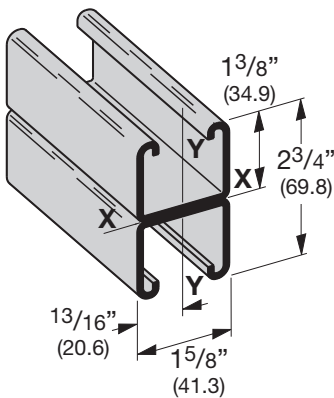

B32A

Wt. 3.40 Lbs./Ft. (5.06 kg/m)

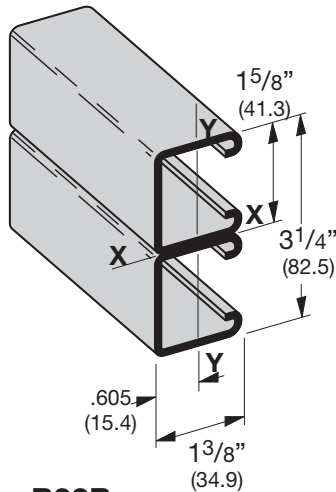

B32B

Wt. 3.40 Lbs./Ft. (5.06 kg/m)

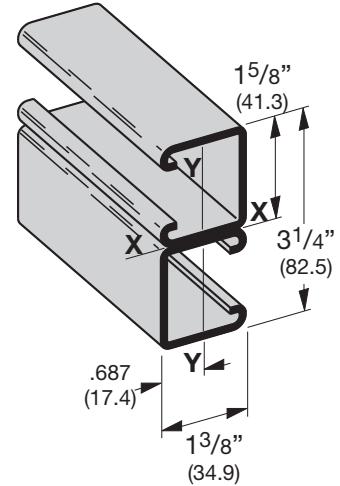

B32C

Wt. 3.40 Lbs./Ft. (5.06 kg/m)

Reference page 14 for general fitting and standard finish specifications.

B32 Beam & Column Loading Data

BEAM LOADING

Beam Span In. mm		Channel Style	Uniform Load and Deflection				Uniform Load @ Deflection =			
			Lbs. kN		In. mm		1/240 Span		1/360 Span	
			Lbs.	kN	In.	mm	Lbs.	kN	Lbs.	kN
12	(305)	B32	2210	(9.83)	.016	(.40)	2210	(9.83)	2210	(9.83)
		B32A	2210*	(9.83)	.003	(.07)	2210*	(9.83)	2210*	(9.83)
24	(609)	B32	1299	(5.78)	.065	(1.65)	1299	(5.78)	1299	(5.78)
		B32A	2210*	(9.83)	.022	(.56)	2210*	(9.83)	2210*	(9.83)
36	(914)	B32	866	(3.85)	.147	(3.73)	866	(3.85)	587	(2.61)
		B32A	2210*	(9.83)	.076	(1.93)	2210*	(9.83)	2210*	(9.83)
48	(1219)	B32	649	(2.89)	.262	(6.65)	495	(2.20)	330	(1.47)
		B32A	1817	(8.08)	.148	(3.76)	1817	(8.08)	1638	(7.28)
60	(1524)	B32	520	(2.31)	.410	(10.41)	317	(1.41)	211	(0.94)
		B32A	1454	(6.47)	.231	(5.87)	1454	(6.47)	1048	(4.66)
72	(1829)	B32	433	(1.92)	.590	(14.98)	220	(0.98)	147	(0.65)
		B32A	1211	(5.39)	.333	(8.46)	1092	(4.86)	728	(3.24)
84	(2133)	B32	371	(1.65)	.803	(20.39)	162	(0.72)	108	(0.48)
		B32A	1038	(4.62)	.453	(11.50)	802	(3.57)	535	(2.38)
96	(2438)	B32	325	(1.44)	1.049	(26.64)	124	(0.55)	83	(0.37)
		B32A	909	(4.04)	.591	(15.01)	614	(2.73)	410	(1.82)
108	(2743)	B32	289	(1.28)	1.327	(33.70)	98	(0.43)	65	(0.29)
		B32A	808	(3.59)	.749	(19.02)	485	(2.16)	324	(1.44)
120	(3048)	B32	260	(1.15)	1.639	(41.63)	79	(0.35)	53	(0.23)
		B32A	727	(3.23)	.924	(23.47)	393	(1.75)	262	(1.16)

Based on simple beam condition using an allowable design stress of 25,000 psi (172 MPa) in accordance with MFMA, with adequate lateral bracing (see page 11 for further explanation). Actual yield point of cold rolled steel is 42,000 psi. To determine concentrated load capacity at mid span, multiply uniform load by 0.5 and corresponding deflection by 0.8. *Failure determined by weld shear.

COLUMN LOADING

Unbraced Height In. mm		Channel Style	Max. Column Loading K = .80				Max. Column Loading (Loaded @ C.G.)					
			Loaded@ C.G.		Loaded@ Slot Face		K = .65		K = 1.0		K = 1.2	
			Lbs.	kN	Lbs.	kN	Lbs.	kN	Lbs.	kN	Lbs.	kN
12	(305)	B32	10278	(4.572)	4036	(17.95)	10432	(46.40)	10035	(44.64)	9753	(43.38)
		B32A	21320	(94.83)	6557	(29.17)	21378	(95.09)	21224	(94.41)	21106	(93.88)
24	(609)	B32	9104	(40.49)	3732	(16.60)	9600	(42.70)	8387	(37.31)	7640	(33.98)
		B32A	20806	(92.55)	6431	(28.60)	21039	(93.58)	20421	(90.84)	19950	(88.74)
36	(914)	B32	7640	(33.98)	3323	(14.78)	8479	(37.71)	6520	(29.00)	5425	(24.13)
		B32A	19950	(88.74)	6228	(27.70)	20474	(91.07)	19083	(84.88)	18023	(80.17)
48	(1219)	B32	6151	(27.36)	2877	(12.80)	7265	(32.31)	4778	(21.25)	3870	(17.21)
		B32A	18751	(83.41)	5954	(26.48)	19682	(87.55)	17210	(76.55)	15326	(68.17)
60	(1524)	B32	4778	(21.25)	2435	(10.83)	6060	(26.95)	3693	(16.43)	2994	(13.32)
		B32A	17210	(76.55)	4692	(20.87)	18665	(83.02)	14801	(65.84)	11858	(52.75)
72	(1829)	B32	3870	(17.21)	2089	(9.29)	4923	(21.90)	2994	(13.32)	2403	(10.68)
		B32A	15326	(68.17)	3448	(15.34)	17421	(77.49)	11858	(52.75)	8316	(36.99)
84	(2133)	B32	3243	(14.42)	1817	(8.08)	4114	(18.30)	2489	(11.07)	1807**	(8.04)
		B32A	13100	(58.27)	2609	(11.60)	15951	(70.95)	8798	(39.13)	6110	(27.18)
96	(2438)	B32	2774	(12.34)	1594	(7.09)	3531	(15.70)	1993	(8.86)	1384**	(6.15)
		B32A	10525	(46.82)	2014	(8.96)	14256	(63.41)	6736	(29.96)	4678	(20.81)
108	(2743)	B32	2403	(10.69)	1407	(6.26)	3083	(13.71)	1574**	(7.00)	1093**	(4.86)
		B32A	8316	(36.99)	1592	(7.08)	12334	(54.86)	5322	(23.67)	3696**	(16.44)
120	(3048)	B32	1993	(8.86)	1221	(5.43)	2723	(12.11)	1275**	(5.67)	886**	(3.94)
		B32A	6736	(29.96)	1289	(5.73)	10203	(45.38)	4311	(19.17)	2994**	(13.32)

**Where the slenderness ratio $\frac{KL}{r}$ exceeds 200, and K = end fixity factor, L = actual length and r = radius of gyration.

Reference page 14 for general fitting and standard finish specifications.

B42 Channel & Combinations

B42

- Thickness: 12 Gauge (2.6 mm)
- Standard lengths: 10' (3.05 m) & 20' (6.09 m)
- Standard finishes: Plain, DURA-GREEN™, Pre-Galvanized, Hot-Dipped Galvanized, Stainless Steel Type 304
- Weight: 1.44 Lbs./Ft. (2.14 kg/m)

Note: Also available in 14 gauge (1.9mm) material as B44

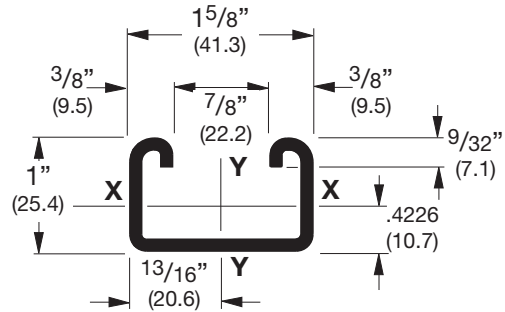
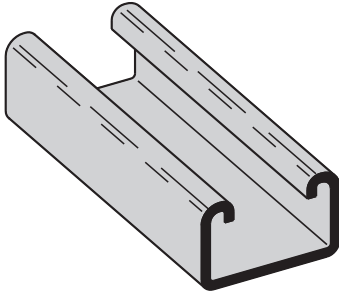

SECTION PROPERTIES

Channel	Weight		Areas of Section		Moment of Inertia (I)		Section Modulus (S)		Radius of Gyration (r)		Moment of Inertia (I)		Section Modulus (S)		Radius of Gyration (r)	
	lbs./ft.	kg/m	sq. in.	cm ²	in. ⁴	cm ⁴	in. ³	cm ³	in.	cm	in. ⁴	cm ⁴	in. ³	cm ³	in.	cm
B42	1.468	(2.18)	.432	(2.79)	.0554	(2.31)	.0968	(1.59)	.358	(.91)	.1645	(6.85)	.2025	(3.32)	.617	(1.57)
B42A	2.936	(4.37)	.864	(5.57)	.2689	(11.19)	.2689	(4.41)	.558	(1.42)	.3292	(13.70)	.4052	(6.64)	.617	(1.57)

Calculations of section properties are based on metal thicknesses as determined by the AISI Cold-Formed Steel Design Manual.

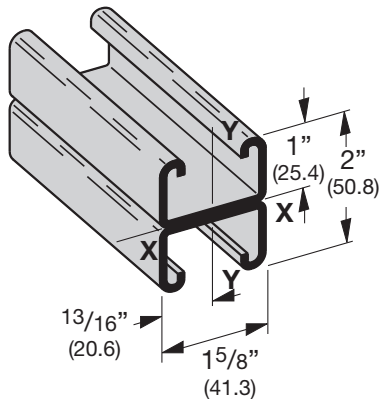

B42A

Wt. 2.88 Lbs./Ft. (4.28 kg/m)

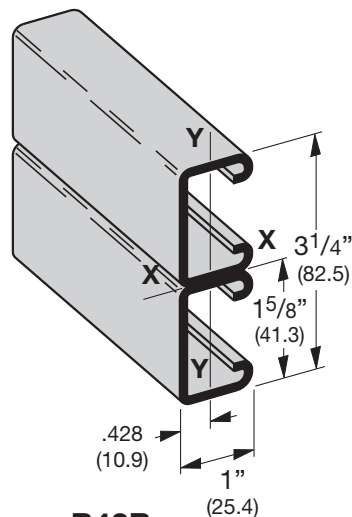

B42B

Wt. 2.88 Lbs./Ft. (4.28 kg/m)

Reference page 14 for general fitting and standard finish specifications.

B42 Beam & Column Loading Data

BEAM LOADING

Beam Span In. mm		Channel Style	Uniform Load and Deflection				Uniform Load @ Deflection =			
			Lbs. kN		In. mm		1/240 Span		1/360 Span	
			Lbs.	kN	In.	mm	Lbs.	kN	Lbs.	kN
12	(305)	B42	1538	(6.84)	.022	(.56)	1538	(6.84)	1538	(6.84)
		B42A	1590*	(7.07)	.005	(.13)	1590*	(7.07)	1590*	(7.07)
24	(609)	B42	769	(3.42)	.088	(2.23)	769	(3.42)	582	(2.59)
		B42A	1590*	(7.07)	.038	(.96)	1590*	(7.07)	1590*	(7.07)
36	(914)	B42	513	(2.28)	.198	(5.03)	388	(1.72)	259	(1.15)
		B42A	1428	(6.35)	.114	(2.89)	1428	(6.35)	1248	(5.55)
48	(1219)	B42	384	(1.71)	.352	(8.94)	218	(0.97)	145	(0.64)
		B42A	1071	(4.76)	.203	(5.15)	1053	(4.68)	702	(3.12)
60	(1524)	B42	308	(1.37)	.550	(13.97)	140	(0.62)	93	(0.41)
		B42A	857	(3.81)	.318	(8.08)	674	(3.00)	449	(2.00)
72	(1829)	B42	256	(1.14)	.792	(20.11)	97	(0.43)	65	(0.29)
		B42A	714	(3.17)	.457	(11.61)	468	(2.08)	312	(1.39)
84	(2133)	B42	220	(0.98)	1.079	(27.40)	71	(0.31)	48	(0.21)
		B42A	612	(2.72)	.623	(15.82)	344	(1.53)	229	(1.02)
96	(2438)	B42	192	(0.85)	1.409	(35.79)	55	(0.24)	36	(0.16)
		B42A	535	(2.38)	.813	(20.65)	263	(1.17)	176	(0.78)
108	(2743)	B42	171	(0.76)	1.783	(45.29)	43	(0.19)	29	(0.13)
		B42A	476	(2.12)	1.029	(26.13)	208	(0.92)	139	(0.62)
120	(3048)	B42	154	(0.68)	2.202	(55.93)	35	(0.15)	23	(0.10)
		B42A	428	(1.90)	1.271	(32.28)	168	(0.75)	112	(0.50)

Based on simple beam condition using an allowable design stress of 25,000 psi (172 MPa) in accordance with MFMA, with adequate lateral bracing (see page 11 for further explanation). Actual yield point of cold rolled steel is 42,000 psi. To determine concentrated load capacity at mid span, multiply uniform load by 0.5 and corresponding deflection by 0.8. *Failure determined by weld shear.

COLUMN LOADING

Unbraced Height In. mm		Channel Style	Max. Column Loading K = .80				Max. Column Loading (Loaded @ C.G.)					
			Loaded@ C.G.		Loaded@ Slot Face		K = .65		K = 1.0		K = 1.2	
			Lbs.	kN	Lbs.	kN	Lbs.	kN	Lbs.	kN	Lbs.	kN
12	(305)	B42	9138	(40.65)	3493	(15.54)	9283	(41.23)	8916	(39.66)	8670	(38.56)
		B42A	21094	(93.83)	5834	(25.95)	21304	(94.76)	20793	(92.49)	20469	(91.05)
24	(609)	B42	8137	(36.19)	3145	(13.99)	8540	(37.99)	7589	(33.76)	7050	(31.36)
		B42A	19757	(87.88)	5585	(24.84)	20299	(90.29)	18964	(84.35)	18094	(80.48)
36	(914)	B42	7050	(31.36)	2722	(12.11)	7657	(34.06)	5925	(26.35)	4335	(19.28)
		B42A	18094	(80.48)	5237	(23.29)	19067	(84.81)	16654	(74.08)	15057	(66.98)
48	(1219)	B42	5405	(24.04)	2227	(9.90)	6786	(30.18)	3512	(15.62)	2439	(10.85)
		B42A	16139	(71.79)	4818	(21.43)	17632	(78.43)	13906	(61.86)	11387	(50.65)
60	(1524)	B42	3512	(15.62)	1718	(7.64)	5272	(23.45)	2247	(9.99)	1561**	(6.94)
		B42A	13906	(61.86)	4352	(19.36)	16008	(71.21)	10710	(47.64)	7531	(33.50)
72	(1829)	B42	2439	(10.85)	1351	(6.01)	3694	(16.43)	1561**	(6.94)	1084**	(4.82)
		B42A	11387	(50.65)	3856	(17.15)	14200	(64.16)	7531	(33.50)	5230	(23.26)
84	(2133)	B42	1792	(7.97)	1087	(4.83)	2714	(12.07)	1147**	(5.10)	796**	(3.54)
		B42A	8645	(38.45)	3332	(14.82)	12206	(54.29)	5533	(24.61)	3842	(17.09)
96	(2438)	B42	1372**	(6.10)	891	(3.96)	2078	(9.24)	878**	(3.90)	-	-
		B42A	6619	(29.44)	2873	(12.78)	10012	(44.53)	4236	(18.84)	2942**	(13.08)
108	(2743)	B42	1084**	(4.82)	743	(3.30)	1642	(7.30)	-	-	-	-
		B42A	5230	(23.26)	2495	(11.10)	7922	(35.24)	3347	(14.89)	2324**	(10.34)
120	(3048)	B42	878**	(3.90)	628	(2.79)	1330**	(5.91)	-	-	-	-
		B42A	4236	(18.84)	2182	(9.70)	6417	(28.54)	2711**	(12.06)	1883**	(8.37)

**Where the slenderness ratio $\frac{KL}{r}$ exceeds 200, and K = end fixity factor, L = actual length and r = radius of gyration.

Reference page 14 for general fitting and standard finish specifications.

B52 Channel & Combinations

B52

- Thickness: 12 Gauge (2.6 mm)
- Standard lengths: 10' (3.05 m) & 20' (6.09 m)
- Standard finishes: Plain, DURA-GREEN™, Pre-Galvanized, Stainless Steel Type 304 or 316, Hot-Dipped Galvanized
- Weight: 1.27 Lbs./Ft. (1.89 kg/m)

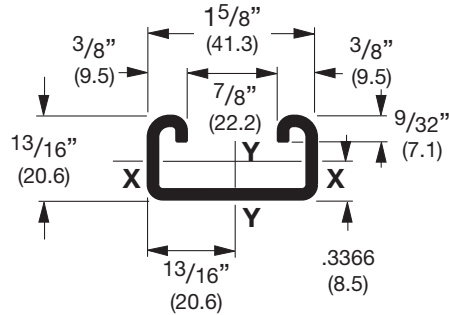
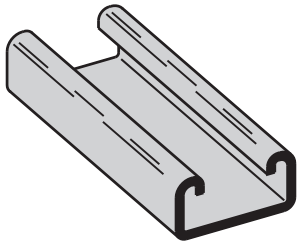

SECTION PROPERTIES

Channel	Weight		Areas of Section		Moment of Inertia (I)		X - X Axis		Radius of Gyration (r)		Moment of Inertia (I)		Section Modulus (S)		Radius of Gyration (r)	
							in. ⁴	cm ⁴	in. ³	cm ³	in.	cm	in. ⁴	cm ⁴	in. ³	cm ³
B52	1.313	(1.95)	.386	(2.49)	.0320	(1.33)	.0673	(1.10)	.288	(.73)	.1404	(5.84)	.1728	(2.83)	.603	(1.53)
B52A	2.627	(3.91)	.773	(4.99)	.1517	(6.31)	.1868	(3.06)	.443	(1.13)	.2809	(11.69)	.3457	(5.67)	.603	(1.53)

Calculations of section properties are based on metal thicknesses as determined by the AISI Cold-Formed Steel Design Manual.

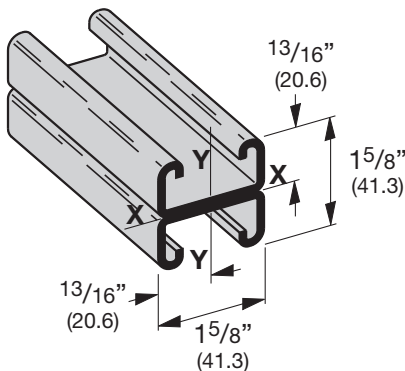

B52A

Wt. 2.54 Lbs./Ft. (3.78 kg/m)

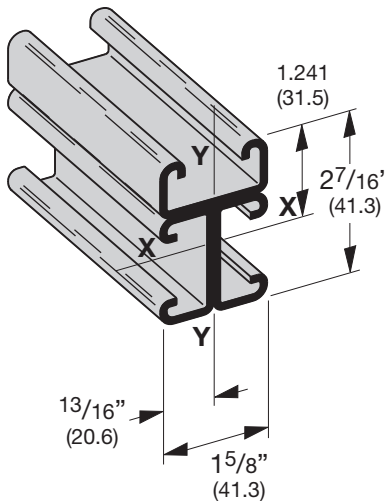

B52B3

Wt. 3.81 Lbs./Ft. (5.67 kg/m)

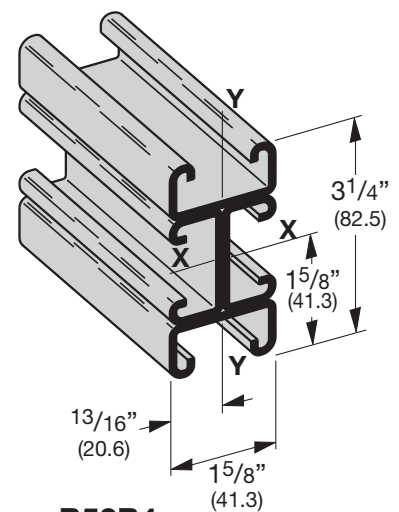

B52B4

Wt. 5.08 Lbs./Ft. (7.56 kg/m)

Reference page 14 for general fitting and standard finish specifications.

B52 Beam & Column Loading Data

BEAM LOADING

Beam Span In. mm		Channel Style	Uniform Load and Deflection				Uniform Load @ Deflection =			
			Lbs. kN		In. mm		1/240 Span		1/360 Span	
			Lbs.	kN	In.	mm	Lbs.	kN	Lbs.	kN
12	(305)	B52 B52A	1079 1270*	(4.80) (5.65)	.026 .006	(.66) (.15)	1079 1270*	(4.80) (5.65)	1079 1270*	(4.80) (5.65)
24	(609)	B52 B52A	539 1270*	(2.40) (5.65)	.106 .052	(2.69) (1.32)	506 1270*	(2.25) (5.65)	337 1270*	(1.50) (5.65)
36	(914)	B52 B52A	360 1013	(1.60) (4.50)	.240 .141	(6.09) (3.58)	225 1013	(1.00) (4.50)	150 719	(0.67) (3.20)
48	(1219)	B52 B52A	270 759	(1.20) (3.37)	.427 .250	(10.84) (6.35)	126 607	(0.56) (2.70)	84 404	(0.37) (1.80)
60	(1524)	B52 B52A	216 608	(0.96) (2.70)	.667 .391	(16.94) (9.93)	81 388	(0.36) (1.72)	54 259	(0.24) (1.15)
72	(1829)	B52 B52A	180 506	(0.80) (.225)	.960 .563	(24.38) (14.30)	56 270	(0.25) (1.20)	37 180	(0.16) (0.80)
84	(2133)	B52 B52A	154 434	(0.68) (1.93)	1.307 .766	(33.20) (19.45)	41 198	(0.18) (0.88)	28 132	(0.12) (0.59)
96	(2438)	B52 B52A	135 380	(0.60) (1.69)	1.707 1.001	(43.36) (25.42)	32 152	(0.14) (0.67)	21 101	(0.93) (0.45)
108	(2743)	B52 B52A	120 338	(0.53) (1.50)	2.160 1.267	(54.86) (32.18)	25 120	(0.11) (0.53)	17 80	(0.75) (0.35)
120	(3048)	B52 B52A	108 304	(0.48) (.135)	2.667 1.564	(67.74) (39.72)	20 97	(0.89) (0.43)	13 65	(0.58) (0.29)

Based on simple beam condition using an allowable design stress of 25,000 psi (172 MPa) in accordance with MFMA, with adequate lateral bracing (see page 11 for further explanation). Actual yield point of cold rolled steel is 42,000 psi. To determine concentrated load capacity at mid span, multiply uniform load by 0.5 and corresponding deflection by 0.8. *Failure determined by weld shear.

COLUMN LOADING

Unbraced Height In. mm		Channel Style	Max. Column Loading K = .80				Max. Column Loading (Loaded @ C.G.)					
			Loaded@ C.G.		Loaded@ Slot Face		K = .65		K = 1.0		K = 1.2	
			Lbs.	kN	Lbs.	kN	Lbs.	kN	Lbs.	kN	Lbs.	kN
12	(305)	B52 B52A	8407 19160	(37.36) (85.23)	3162 5290	(14.06) (23.53)	8543 19425	(38.00) (86.41)	8205 18777	(36.50) (83.52)	7989 18363	(35.54) (81.68)
24	(609)	B52 B52A	7519 17444	(33.44) (77.59)	2755 4955	(12.25) (22.04)	7879 18144	(35.05) (80.71)	6521 16412	(29.01) (73.00)	5397 15275	(24.01) (67.94)
36	(914)	B52 B52A	5397 15275	(24.01) (67.94)	2152 4496	(9.57) (20.00)	6653 16547	(29.59) (73.60)	3616 13376	(16.08) (59.50)	2511 11243	(11.17) (50.01)
48	(1219)	B52 B52A	3178 12692	(14.13) (56.46)	1560 3963	(6.94) (17.63)	4785 14667	(21.28) (65.24)	2034 9683	(9.05) (43.07)	1412** 6780	(6.28) (30.16)
60	(1524)	B52 B52A	2034 9683	(9.05) (43.07)	1159 3383	(5.15) (15.05)	3081 12516	(13.70) (55.67)	1302** 6248	(5.79) (27.79)	904** 4339	(4.02) (19.30)
72	(1829)	B52 B52A	1412** 6780	(6.28) (30.16)	891 2799	(3.96) (12.45)	2139 10084	(9.51) (44.85)	904** 4339	(4.02) (19.30)	- 3013	- (13.42)
84	(2133)	B52 B52A	1038** 4981	(4.62) (22.15)	704 2337	(3.13) (10.39)	1572 7545	(6.99) (33.56)	664** 3188	(2.95) (14.18)	- 2214**	- (9.85)
96	(2438)	B52 B52A	794** 3814	(3.53) (16.96)	570 1973	(2.53) (8.77)	1203** 5777	(5.35) (25.70)	- 2441**	- (10.86)	- 1695**	- (7.54)
108	(2743)	B52 B52A	- 3013	- (13.40)	470 1684	(2.09) (7.49)	951** 4564	(4.23) (20.30)	- 1928**	- (8.57)	- 1339**	- (5.95)
120	(3048)	B52 B52A	- 2441**	- (10.86)	394 1452	(1.75) (6.46)	770** 3697	(3.42) (16.44)	- 1562**	- (6.95)	- -	- -

**Where the slenderness ratio $\frac{KL}{r}$ exceeds 200, and K = end fixity factor, L = actual length and r = radius of gyration.

Reference page 14 for general fitting and standard finish specifications.

B54 Channel & Combinations

B54

- Thickness: 14 Gauge (1.9 mm)
- Standard lengths: 10' (3.05 m) & 20' (6.09 m)
- Standard finishes: Plain, DURA-GREEN™, Pre-Galvanized, Hot-Dipped Galvanized, Stainless Steel Type 304 or 316, Aluminum
- Weight: .97 Lbs./Ft. (1.44 kg/m)

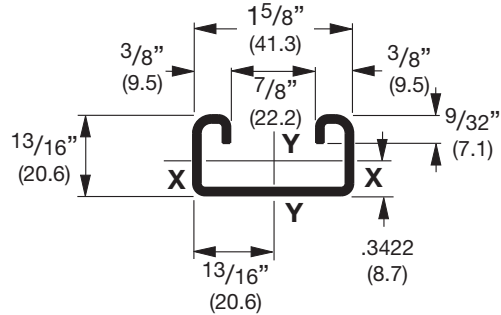
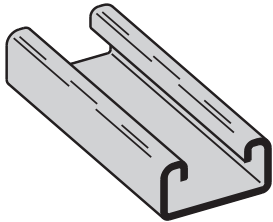

SECTION PROPERTIES

Channel	Weight		Areas of Section		Moment of Inertia (I)		Section Modulus (S)		Radius of Gyration (r)		X - X Axis		Y - Y Axis	
											Moment of Inertia (I)		Section Modulus (S)	
	lbs./ft.	kg/m	sq. in.	cm ²	in. ⁴	cm ⁴	in. ³	cm ³	in.	cm	in. ⁴	cm ⁴	in. ³	cm ³
B54	1.016	(1.51)	.299	(1.93)	.0263	(1.09)	.0560	(.92)	.297	(.75)	.1106	(4.60)	.1361	(2.23)
B54A	2.032	(3.02)	.598	(3.86)	.1226	(5.10)	.1510	(2.47)	.453	(1.15)	.2212	(9.12)	.2722	(4.46)

Calculations of section properties are based on metal thicknesses as determined by the AISI Cold-Formed Steel Design Manual.

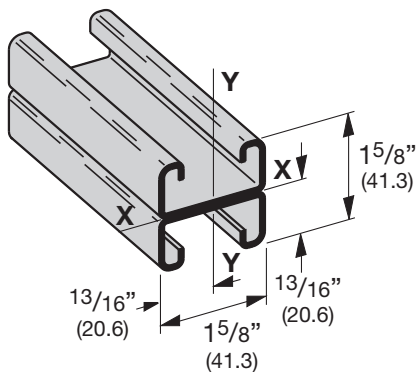

B54A

Wt. 1.94 Lbs./Ft. (2.89 kg/m)

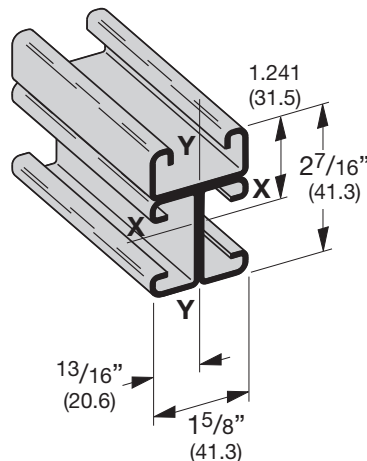

B54B3

Wt. 2.91 Lbs./Ft. (4.33 kg/m)

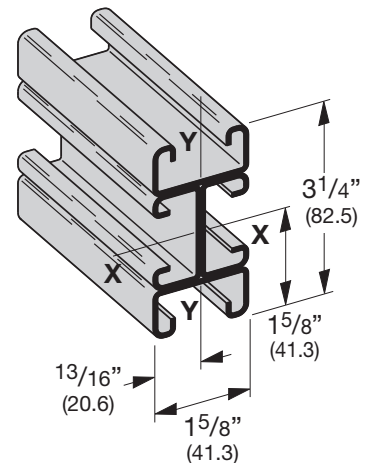

B54B4

Wt. 3.88 Lbs./Ft. (5.77 kg/m)

Reference page 14 for general fitting and standard finish specifications.

B54 Beam & Column Loading Data

BEAM LOADING

Beam Span In. mm		Channel Style	Uniform Load and Deflection				Uniform Load @ Deflection =			
			1/240 Span		1/360 Span		1/240 Span		1/360 Span	
			Lbs.	kN	In.	mm	Lbs.	kN	Lbs.	kN
12	(305)	B54	870	(3.87)	.027	(.68)	870	(3.87)	870	(3.87)
		B54A	870*	(3.87)	.005	(.13)	870*	(3.87)	870*	(3.87)
24	(609)	B54	465	(2.07)	.108	(2.74)	430	(1.91)	287	(1.27)
		B54A	870*	(3.87)	.043	(1.09)	870*	(3.87)	870*	(3.87)
36	(914)	B54	310	(1.38)	.243	(6.17)	191	(0.85)	127	(0.56)
		B54A	832	(3.70)	.141	(3.58)	832	(3.70)	591	(2.63)
48	(1219)	B54	233	(1.03)	.432	(10.97)	108	(0.48)	72	(0.32)
		B54A	624	(2.77)	.250	(6.35)	499	(2.22)	332	(1.48)
60	(1524)	B54	186	(0.83)	.676	(17.17)	69	(0.31)	46	(0.20)
		B54A	499	(2.22)	.391	(9.93)	319	(1.42)	213	(0.95)
72	(1829)	B54	155	(0.69)	.973	(24.71)	48	(0.21)	32	(0.14)
		B54A	416	(1.85)	.563	(14.30)	222	(0.99)	148	(0.66)
84	(2133)	B54	133	(0.59)	1.324	(33.63)	35	(0.15)	23	(0.10)
		B54A	357	(1.59)	.766	(19.45)	163	(0.72)	109	(0.48)
96	(2438)	B54	116	(0.51)	1.730	(43.94)	27	(0.12)	18	(0.80)
		B54A	312	(1.39)	1.001	(25.42)	125	(0.55)	83	(0.37)
108	(2743)	B54	103	(0.46)	2.189	(55.60)	21	(0.93)	14	(0.62)
		B54A	277	(1.23)	1.267	(32.18)	98	(0.43)	66	(0.29)
120	(3048)	B54	93	(0.41)	2.703	(68.65)	17	(0.75)	11	(0.49)
		B54A	250	(1.11)	1.564	(39.72)	80	(0.35)	53	(0.23)

Based on simple beam condition using an allowable design stress of 25,000 psi (172 MPa) in accordance with MFMA, with adequate lateral bracing (see page 11 for further explanation). Actual yield point of cold rolled steel is 42,000 psi. To determine concentrated load capacity at mid span, multiply uniform load by 0.5 and corresponding deflection by 0.8. *Failure determined by weld shear.

COLUMN LOADING

Unbraced Height In. mm		Channel Style	Max. Column Loading K = .80				Max. Column Loading (Loaded @ C.G.)					
			Loaded@ C.G.		Loaded@ Slot Face		K = .65		K = 1.0		K = 1.2	
			Lbs.	N	Lbs.	N	Lbs.	N	Lbs.	N	Lbs.	N
12	(305)	B54	6186	(27.51)	2586	(11.50)	6284	(27.95)	6032	(26.83)	5857	(26.05)
		B54A	12763	(56.77)	4060	(18.06)	12835	(57.09)	12645	(56.25)	12501	(55.61)
24	(609)	B54	5464	(24.30)	2254	(10.02)	5763	(25.63)	4968	(22.10)	4300	(19.13)
		B54A	12135	(53.98)	3857	(17.16)	12420	(55.25)	11663	(51.88)	11087	(49.32)
36	(914)	B54	4300	(19.13)	1816	(8.08)	5043	(22.43)	3076	(13.68)	2136	(9.50)
		B54A	11087	(49.32)	3549	(15.79)	11728	(52.17)	10026	(44.60)	8729	(38.83)
48	(1219)	B54	2703	(12.02)	1341	(5.96)	3920	(17.44)	1730	(7.69)	1201	(5.34)
		B54A	9620	(42.79)	3169	(14.09)	10759	(47.86)	7734	(34.40)	5571	(24.78)
60	(1524)	B54	1730	(7.69)	995	(4.42)	2621	(11.66)	1107**	(4.92)	769**	(3.42)
		B54A	7734	(34.40)	2745	(12.21)	9514	(42.32)	5134	(22.84)	3566	(15.86)
72	(1829)	B54	1201	(5.34)	763	(3.39)	1820	(8.09)	769**	(3.42)	534**	(2.37)
		B54A	5571	(24.78)	2291	(10.19)	7992	(35.50)	3566	(15.86)	2476	(11.01)
84	(2133)	B54	883**	(3.93)	603	(2.68)	1337	(5.95)	565**	(2.51)	-	-
		B54A	4093	(18.20)	1913	(8.51)	6200	(27.58)	2620	(11.65)	1819**	(8.09)
96	(2438)	B54	676**	(3.01)	487	(2.16)	1024**	(4.55)	-	-	-	-
		B54A	3134	(13.94)	1616	(7.19)	4747	(21.11)	2006**	(8.92)	1393**	(6.19)
108	(2743)	B54	534**	(2.37)	401	(1.78)	809**	(3.60)	-	-	-	-
		B54A	2476	(11.01)	1380	(6.14)	3751	(16.68)	1585**	(7.05)	1100**	(4.89)
120	(3048)	B54	-	-	336	(1.49)	655**	(2.91)	-	-	-	-
		B54A	2006**	(8.92)	1190	(5.29)	3038	(13.51)	1284**	(5.71)	-	-

**Where the slenderness ratio $\frac{KL}{r}$ exceeds 200, and K = end fixity factor, L = actual length and r = radius of gyration.

Reference page 14 for general fitting and standard finish specifications.

B56 Channel & Combinations

B56

- Thickness: 16 Gauge (1.5 mm)
- Standard lengths: 10' (3.05 m) & 20' (6.09 m)
- Standard finishes: Plain, DURA-GREEN™, Pre-Galvanized, Hot-Dipped Galvanized
- Weight: .85 Lbs./Ft. (1.26 kg/m)

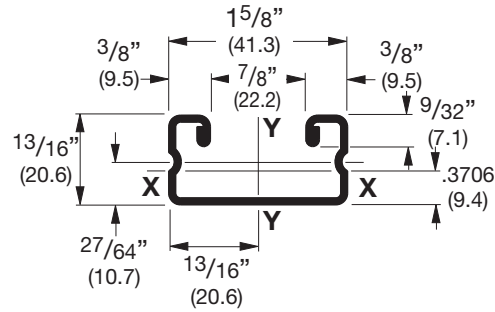
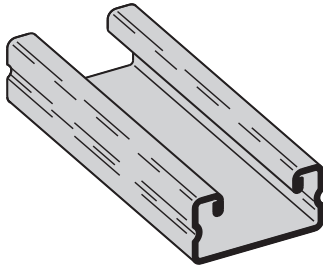

SECTION PROPERTIES

Channel	Weight		Areas of Section		Moment of Inertia (I)		Section Modulus (S)		X - X Axis		Moment of Inertia (I)		Y - Y Axis		Section Modulus (S)		Radius of Gyration (r)	
									in. ⁴	cm ⁴			in. ³	cm ³				
B56	.894	(1.33)	.263	(1.70)	.0241	(1.00)	.0546	(.89)	.303	(.77)	.0966	(4.02)	.1189	(1.95)	.606	(1.54)	.606	(1.54)
B56A	1.789	(2.66)	.526	(3.39)	.1205	(5.02)	.1484	(2.43)	.479	(1.22)	.1931	(8.04)	.2377	(3.89)	.606	(1.54)	.606	(1.54)

Calculations of section properties are based on metal thicknesses as determined by the AISI Cold-Formed Steel Design Manual.

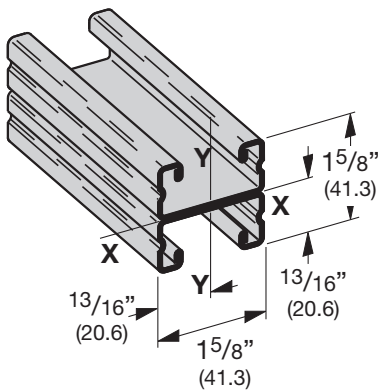

B56A

Wt. 1.70 Lbs./Ft. (2.53 kg/m)

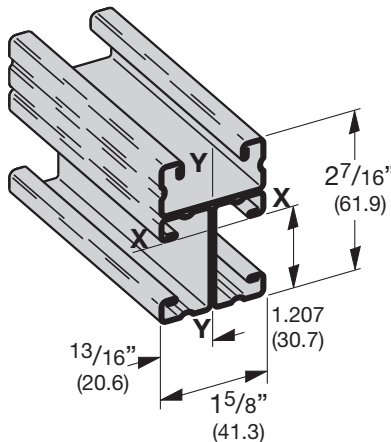

B56B3

Wt. 2.55 Lbs./Ft. (3.79 kg/m)

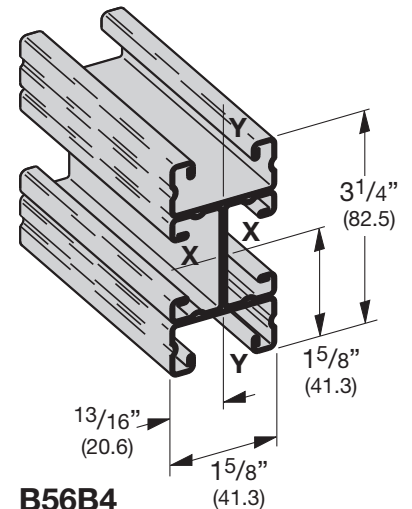

B56B4

Wt. 3.40 Lbs./Ft. (5.06 kg/m)

Reference page 14 for general fitting and standard finish specifications.

B56 Beam & Column Loading Data

BEAM LOADING

Beam Span In. mm		Channel Style	Uniform Load and Deflection				Uniform Load @ Deflection =			
			Lbs. kN		In. mm		1/240 Span Lbs. kN		1/360 Span Lbs. kN	
12	(305)	B56	610	(2.73)	.027	(.68)	610	(2.71)	610	(2.71)
		B56A	610*	(2.71)	.004	(.10)	610*	(2.71)	610*	(2.71)
24	(609)	B56	405	(1.80)	.109	(2.77)	372	(1.65)	248	(1.10)
		B56A	610*	(2.71)	.035	(.89)	610*	(2.71)	610*	(2.71)
36	(914)	B56	270	(1.20)	.245	(6.22)	165	(0.73)	110	(0.49)
		B56A	610*	(2.71)	.121	(3.07)	610*	(2.71)	502	(2.23)
48	(1219)	B56	202	(0.90)	.435	(11.05)	93	(0.41)	62	(0.27)
		B56A	530	(2.36)	.250	(6.35)	423	(1.88)	282	(1.70)
60	(1524)	B56	162	(0.72)	.680	(17.27)	59	(0.26)	40	(0.18)
		B56A	424	(1.88)	.391	(9.93)	271	(1.20)	181	(0.80)
72	(1829)	B56	135	(0.60)	.980	(24.89)	41	(0.18)	28	(0.12)
		B56A	353	(1.57)	.563	(14.30)	188	(0.83)	125	(0.55)
84	(2133)	B56	116	(0.51)	1.334	(33.88)	30	(0.13)	20	(0.89)
		B56A	303	(1.35)	.766	(19.45)	138	(0.61)	92	(0.41)
96	(2438)	B56	101	(0.45)	1.742	(44.24)	23	(0.10)	15	(0.67)
		B56A	265	(1.18)	1.001	(25.42)	106	(0.47)	71	(0.31)
108	(2743)	B56	90	(0.40)	2.205	(56.01)	18	(0.80)	12	(0.53)
		B56A	236	(1.05)	1.267	(32.18)	84	(0.37)	56	(0.25)
120	(3048)	B56	81	(0.36)	2.722	(69.14)	15	(0.67)	10	(0.44)
		B56A	212	(0.94)	1.564	(39.72)	68	(0.30)	45	(0.20)

Based on simple beam condition using an allowable design stress of 25,000 psi (172 MPa) in accordance with MFMA, with adequate lateral bracing (see page 11 for further explanation). Actual yield point of cold rolled steel is 42,000 psi. To determine concentrated load capacity at mid span, multiply uniform load by 0.5 and corresponding deflection by 0.8. *Failure determined by weld shear.

COLUMN LOADING

Unbraced Height In. mm		Channel Style	Max. Column Loading K = .80				Max. Column Loading (Loaded @ C.G.)					
			Loaded@ C.G.		Loaded@ Slot Face		K = .65		K = 1.0		K = 1.2	
			Lbs.	kN	Lbs.	kN	Lbs.	kN	Lbs.	kN	Lbs.	kN
12	(305)	B56	4968	(22.10)	2182	(9.70)	5044	(22.44)	4845	(21.55)	4702	(20.91)
		B56A	10237	(45.53)	3365	(14.97)	10291	(45.77)	10148	(45.14)	10039	(44.65)
24	(609)	B56	4367	(19.42)	1903	(8.46)	4624	(20.57)	3985	(17.72)	3572	(15.89)
		B56A	9762	(43.42)	3202	(14.24)	9977	(44.38)	9405	(41.83)	8969	(39.89)
36	(914)	B56	3572	(15.89)	1557	(6.92)	4034	(17.94)	2658	(11.82)	1845	(8.21)
		B56A	8969	(39.89)	2955	(13.14)	9454	(42.05)	8167	(36.33)	7186	(31.96)
48	(1219)	B56	2335	(10.38)	1164	(5.18)	3290	(14.63)	1495	(6.65)	1038	(4.62)
		B56A	7860	(34.96)	2649	(11.78)	8722	(38.80)	6434	(28.62)	4731	(21.04)
60	(1524)	B56	1495	(6.65)	862	(3.83)	2264	(10.07)	957	(4.26)	664**	(2.95)
		B56A	6434	(28.62)	2307	(10.26)	7780	(34.61)	4360	(19.39)	3028	(13.47)
72	(1829)	B56	1038	(4.62)	661	(2.94)	1572	(6.99)	664**	(2.95)	461**	(2.05)
		B56A	4731	(21.04)	1937	(8.61)	6629	(29.49)	3028	(13.47)	2103	(9.35)
84	(2133)	B56	763**	(3.39)	522	(2.32)	1155	(5.14)	488**	(2.17)	-	-
		B56A	3476	(15.46)	1619	(7.20)	5269	(23.44)	2224	(9.89)	1545**	(6.87)
96	(2438)	B56	584**	(2.60)	422	(1.88)	884**	(3.93)	-	-	-	-
		B56A	2661	(11.84)	1368	(6.08)	4031	(17.93)	1703**	(7.57)	1183**	(5.26)
108	(2743)	B56	461**	(2.05)	348	(1.55)	699**	(3.11)	-	-	-	-
		B56A	2103	(9.35)	1169	(5.20)	3185	(14.17)	1346**	(5.99)	934**	(4.15)
120	(3048)	B56	-	-	291	(1.29)	566**	(2.42)	-	-	-	-
		B56A	1703**	(7.57)	1008	(4.48)	2580	(11.47)	1090**	(4.85)	-	-

**Where the slenderness ratio $\frac{KL}{r}$ exceeds 200, and K = end fixity factor, L = actual length and r = radius of gyration.

Reference page 14 for general fitting and standard finish specifications.

Telescoping Channel

BTS22TH

- Can be secured at any point of system
- Order BTS22TH & B22TH separately
- Thickness: 12 Gauge (1.5 mm)
- Standard lengths: 10' (3.05 m)
- Standard finishes: DURA-GREEN™, Yellow Zinc Dichromate, Hot-Dipped Galvanized

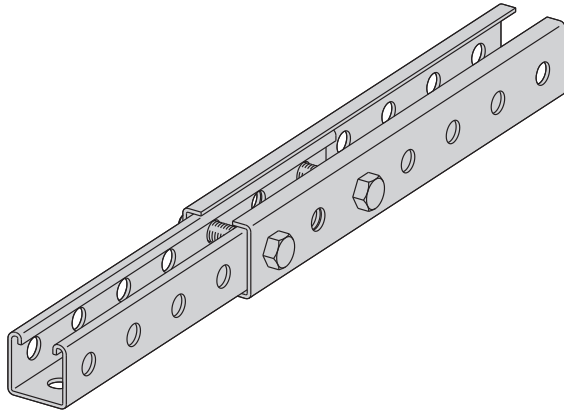

Slip Load Data

Resistance to slip*
700 lbs.

1/4" thick 2-hole fitting with (2) 1/2" bolts & channel nuts.
Typical of many standard fittings.

Resistance to slip*
3600 lbs.

1/2" bolt & nut

*With a safety factor of 3

BTS22TH TELESCOPING STRUT

Fits over all 15/8" x 15/8" channels 9/16" holes on 17/8" centers 12 gauge material thickness

Section Properties			X-X Axis				Y-Y Axis			
Channel	Weight lbs./ft.	Area In ²	C _x In	I _x In ⁴	S _x In ³	r _x In	C _y In	I _y In ⁴	S _y In ³	r _y In
BTS22TH	1.934	0.4578	1.0009	0.2525	0.2523	0.7426	0.9375	0.2757	0.2941	0.7761

Section properties are based on nominal metal thickness, and overall dimensions.

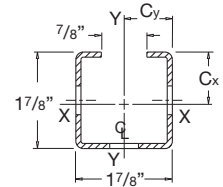

B22TH THREE HOLE STRUT

9/16" holes on 17/8" centers 12 gauge material thickness

Section Properties			X-X Axis				Y-Y Axis			
Channel	Weight lbs./ft.	Area In ²	C _x In	I _x In ⁴	S _x In ³	r _x In	C _y In	I _y In ⁴	S _y In ³	r _y In
B22TH	1.760	0.3863	0.8245	0.1596	0.1936	0.6400	0.8125	0.1719	0.2116	0.6642

Section properties are based on nominal metal thickness, and overall dimensions.

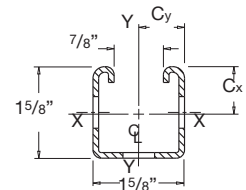

COMBINATION OF BTS22TH & B22TH

Section Properties			X-X Axis				Y-Y Axis			
Channel Combination	Weight lbs./ft.	Area In ²	C _x In	I _x In ⁴	S _x In ³	r _x In	C _y In	I _y In ⁴	S _y In ³	r _y In
BTS22TH/B22TH	3.597	0.8474	0.9773	0.4126	0.4222	0.6978	0.9375	0.4476	0.4774	0.7268

Section properties are based on nominal metal thickness, and overall dimensions.

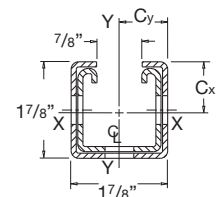

Reference page 14 for general fitting and standard finish specifications.

Telescoping Channel

BEAM LOADING DATA

B22TH

Beam Span in	Beam Load Data x-x Axis			
	Allowable Load lbs*	Resulting Deflection in	Allowable Load @ Deflection=1/240 Span	
			Lbs.	kN
12	2225	0.015	3225	(14.34)
24	1610	0.061	1610	(7.16)
36	1071	0.136	1071	(4.76)
48	800	0.243	658	(2.92)
60	637	0.379	417	(1.85)
72	528	0.546	286	(1.27)
84	449	0.743	206	(0.91)
96	390	0.970	153	(0.68)
108	344	1.228	116	(0.51)
120	306	1.516	90	(0.40)

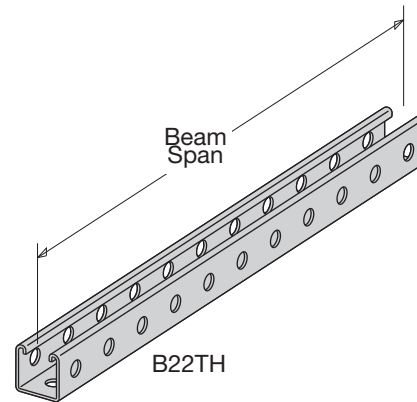

BTS22TH

Beam Span in	Beam Load Data x-x Axis			
	Allowable Load lbs*	Resulting Deflection in	Allowable Load @ Deflection=1/240 Span	
			Lbs.	kN
12	4203	0.012	4203	(18.69)
24	2099	0.050	2099	(9.33)
36	1396	0.112	1396	(6.21)
48	1044	0.200	1044	(4.64)
60	831	0.312	664	(2.95)
72	689	0.450	456	(2.03)
84	587	0.612	330	(1.48)
96	510	0.799	248	(1.10)
108	450	1.012	190	(0.84)
120	401	1.249	149	(0.66)

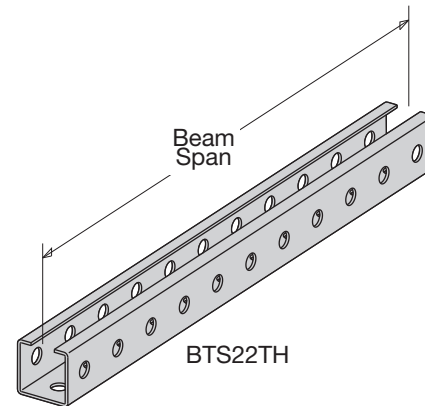

BTS22TH & B22TH TELESCOPING MEMBERS OF EQUAL LENGTH

Beam Span in	Beam Load Data x-x Axis			
	Allowable Load lbs*	Resulting Deflection in	Allowable Load @ Deflection=1/240 Span	
			Lbs.	kN
12	7033	0.013	7033	(31.28)
24	3511	0.051	3511	(15.62)
36	2335	0.115	2335	(10.38)
48	1745	0.205	1705	(7.58)
60	1389	0.320	1082	(4.81)
72	1151	0.460	742	(3.30)
84	980	0.627	536	(2.38)
96	851	0.819	401	(1.78)
108	749	1.036	307	(1.36)
120	668	1.279	239	(1.06)

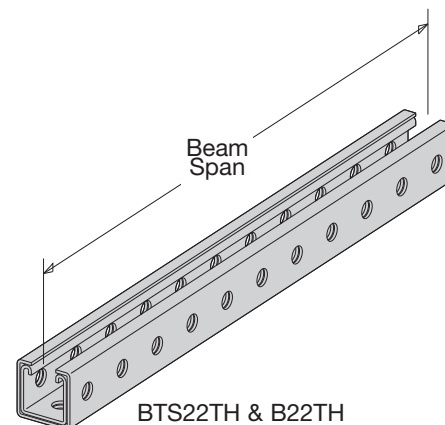

*Based on simple beam condition using an allowable design stress of 25,000 psi (172 MPa) with adequate lateral bracing (see page 11 for further explanation). To determine concentrated load capacity at mid span, multiply uniform load by 0.5 and corresponding deflection by 0.8.

Reference page 14 for general fitting and standard finish specifications.

Channel Hole Patterns

B11SH THRU B56SH SH TYPE CHANNEL

• For beam loads use 90% of Channel Loading Chart

Part No.	Thickness		Height H		Weight	
	In.	mm	In.	mm	Lbs./Ft.	kg/m
B11SH	12 Ga.	(2.6)	3 ¹ / ₄ "	(82.5)	2.97	(4.42)
B12SH	12 Ga.	(2.6)	2 ⁷ / ₁₆ "	(61.9)	2.39	(3.55)
B22SH	12 Ga.	(2.6)	1 ⁵ / ₈ "	(41.3)	1.82	(2.71)
B24SH	14 Ga.	(1.9)	1 ⁵ / ₈ "	(41.3)	1.34	(1.99)
B26SH	16 Ga.	(1.5)	1 ⁵ / ₈ "	(41.3)	1.07	(1.59)
B32SH	12 Ga.	(2.6)	1 ³ / ₈ "	(34.9)	1.62	(2.41)
B42SH	12 Ga.	(2.6)	1"	(25.4)	1.36	(2.02)
B52SH	12 Ga.	(2.6)	1 ³ / ₁₆ "	(20.6)	1.19	(1.77)
B54SH	14 Ga.	(1.9)	1 ³ / ₁₆ "	(20.6)	.91	(1.35)
B56SH	16 Ga.	(1.5)	1 ³ / ₁₆ "	(20.6)	.80	(1.19)

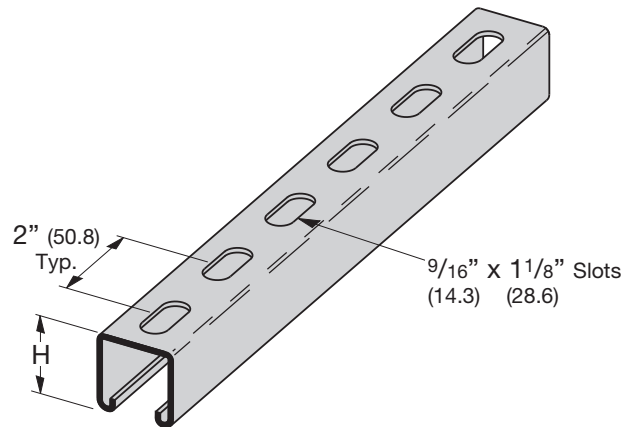

B11S THRU B56S S TYPE CHANNEL

• For beam loads use 90% of Channel Loading Chart

Part No.	Thickness		Height H		Weight	
	In.	mm	In.	mm	Lbs./Ft.	kg/m
B11S	12 Ga.	(2.6)	3 ¹ / ₄ "	(82.5)	2.94	(4.37)
B12S	12 Ga.	(2.6)	2 ⁷ / ₁₆ "	(61.9)	2.36	(3.51)
B22S	12 Ga.	(2.6)	1 ⁵ / ₈ "	(41.3)	1.79	(2.66)
B24S	14 Ga.	(1.9)	1 ⁵ / ₈ "	(41.3)	1.32	(1.96)
B26S	16 Ga.	(1.5)	1 ⁵ / ₈ "	(41.3)	1.06	(1.58)
B32S	12 Ga.	(2.6)	1 ³ / ₈ "	(34.9)	1.59	(2.36)
B42S	12 Ga.	(2.6)	1"	(25.4)	1.33	(1.98)
B52S	12 Ga.	(2.6)	1 ³ / ₁₆ "	(20.6)	1.16	(1.72)
B54S	14 Ga.	(1.9)	1 ³ / ₁₆ "	(20.6)	.89	(1.32)
B56S	16 Ga.	(1.5)	1 ³ / ₁₆ "	(20.6)	.79	(1.17)

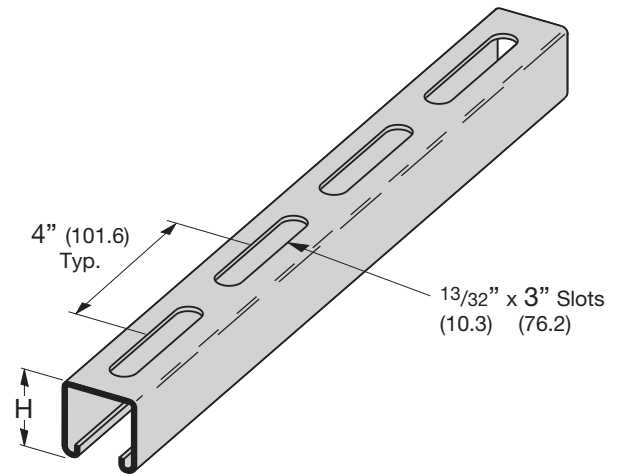

B11H17/8 THRU B56H17/8 H17/8 TYPE CHANNEL

• For beam loads use 90% of Channel Loading Chart

Part No.	Thickness		Height H		Weight	
	In.	mm	In.	mm	Lbs./Ft.	kg/m
B11H17/8	12 Ga.	(2.6)	3 ¹ / ₄ "	(82.5)	3.00	(4.46)
B12H17/8	12 Ga.	(2.6)	2 ⁷ / ₁₆ "	(61.9)	2.42	(3.60)
B22H17/8	12 Ga.	(2.6)	1 ⁵ / ₈ "	(41.3)	1.85	(2.75)
B24H17/8	14 Ga.	(1.9)	1 ⁵ / ₈ "	(41.3)	1.36	(2.02)
B26H17/8	16 Ga.	(1.5)	1 ⁵ / ₈ "	(41.3)	1.09	(1.62)
B32H17/8	12 Ga.	(2.6)	1 ³ / ₈ "	(34.9)	1.65	(2.45)
B42H17/8	12 Ga.	(2.6)	1"	(25.4)	1.39	(2.07)
B52H17/8	12 Ga.	(2.6)	1 ³ / ₁₆ "	(20.6)	1.22	(1.81)
B54H17/8	14 Ga.	(1.9)	1 ³ / ₁₆ "	(20.6)	.93	(1.38)
B56H17/8	16 Ga.	(1.5)	1 ³ / ₁₆ "	(20.6)	.82	(1.22)

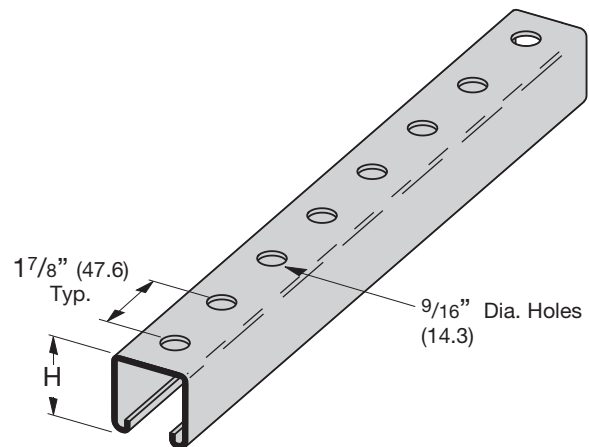

Reference page 14 for general fitting and standard finish specifications.

Channel Hole Patterns

B22TH (TH TYPE CHANNEL)

• For beam loads use 90% of Channel Loading Chart

Part No.	Thickness		Height H		Weight	
	In.	mm	In.	mm	Lbs./Ft.	kg/m
B22TH	12 Ga.	(2.6)	1 ⁵ / ₈ "	(41.3)	1.76	(2.62)

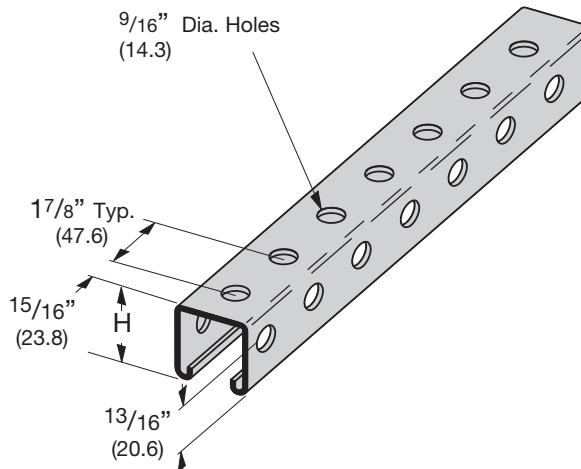

B11KO6 THRU B56KO6 (KO6 TYPE KNOCKOUT CHANNEL)

• For beam loads use 90% of Channel Loading Chart

Part No.	Thickness		Height H		Weight	
	In.	mm	In.	mm	Lbs./Ft.	kg/m
B11KO6	12 Ga.	(2.6)	3 ¹ / ₄ "	(82.5)	3.05	(4.54)
B12KO6	12 Ga.	(2.6)	2 ⁷ / ₁₆ "	(61.9)	2.47	(3.67)
B22KO6	12 Ga.	(2.6)	1 ⁵ / ₈ "	(41.3)	1.90	(2.83)
B24KO6	14 Ga.	(1.9)	1 ⁵ / ₈ "	(41.3)	1.40	(2.08)
B26KO6	16 Ga.	(1.5)	1 ⁵ / ₈ "	(41.3)	1.12	(1.66)
B32KO6	12 Ga.	(2.6)	1 ³ / ₈ "	(34.9)	1.70	(2.53)
B42KO6	12 Ga.	(2.6)	1"	(25.4)	1.44	(2.14)
B52KO6	12 Ga.	(2.6)	1 ³ / ₁₆ "	(20.6)	1.27	(1.89)
B54KO6	14 Ga.	(1.9)	1 ³ / ₁₆ "	(20.6)	.97	(1.44)
B56KO6	16 Ga.	(1.5)	1 ³ / ₁₆ "	(20.6)	.85	(1.26)

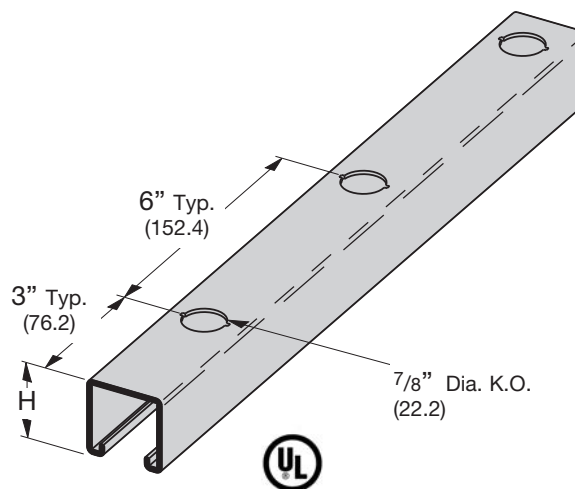

Channel & Combinations

B22SHA (BACK TO BACK SH TYPE CHANNEL)

• For beam loads use 90% of Channel Loading Chart

Part No.	Thickness		Height H		Weight	
	In.	mm	In.	mm	Lbs./Ft.	kg/m
B22SHA	12 Ga.	(2.6)	3 ¹ / ₄ "	(82.5)	3.64	(5.42)
B52SHA	12 Ga.	(2.6)	1 ⁵ / ₈ "	(41.3)	2.38	(1.77)
B54SHA	14 Ga.	(1.9)	1 ⁵ / ₈ "	(41.3)	1.82	(1.35)

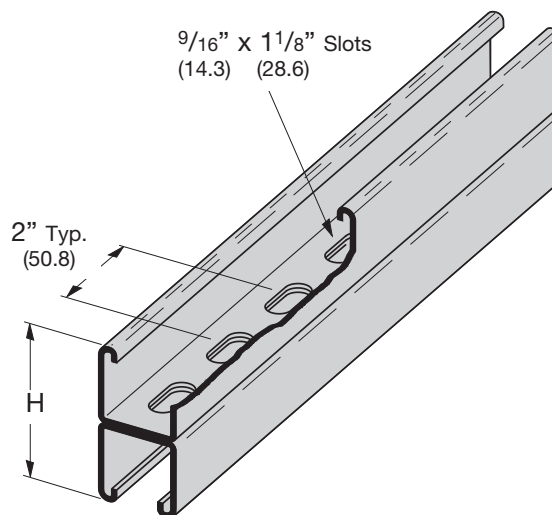

Reference page 14 for general fitting and standard finish specifications.

Channel Hole Patterns

B11S58 THRU B56S58 S58 TYPE CHANNEL

• For beam loads use 90% of Channel Loading Chart

Part No.	Thickness		Height H		Weight	
	In.	mm	In.	mm	Lbs./Ft.	kg/m
B11S58	12 Ga.	(2.6)	3 1/4"	(82.5)	2.94	(4.37)
B12S58	12 Ga.	(2.6)	2 7/16"	(61.9)	2.36	(3.51)
B22S58	12 Ga.	(2.6)	1 5/8"	(41.3)	1.79	(2.66)
B24S58	14 Ga.	(1.9)	1 5/8"	(41.3)	1.32	(1.96)
B26S58	16 Ga.	(1.5)	1 5/8"	(41.3)	1.06	(1.58)
B32S58	12 Ga.	(2.6)	1 3/8"	(34.9)	1.59	(2.36)
B42S58	12 Ga.	(2.6)	1"	(25.4)	1.33	(1.98)
B52S58	12 Ga.	(2.6)	1 3/16"	(20.6)	1.16	(1.72)
B54S58	14 Ga.	(1.9)	1 3/16"	(20.6)	.89	(1.32)
B56S58	16 Ga.	(1.5)	1 3/16"	(20.6)	.79	(1.17)

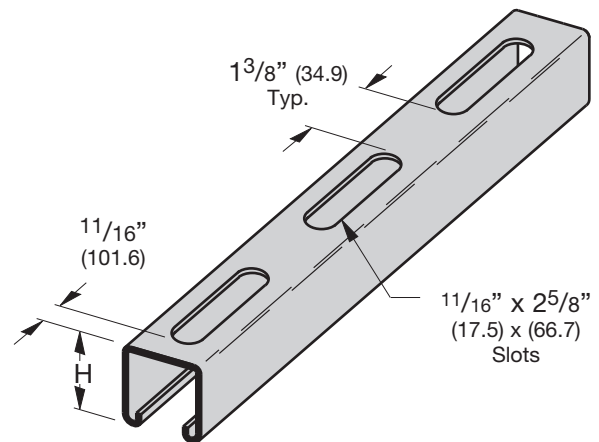

B22M THRU B54M M (MARINE RUNG) TYPE CHANNEL

• For beam loads use 90% of Channel Loading Chart

Part No.	Thickness		Height H		Weight	
	In.	mm	In.	mm	Lbs./Ft.	kg/m
B22M	12 Ga.	(2.6)	1 5/8"	(41.3)	1.79	(2.66)
B24M	14 Ga.	(1.9)	1 5/8"	(41.3)	1.32	(1.96)
B32M	12 Ga.	(2.6)	1 3/8"	(34.9)	1.59	(2.36)
B42M	12 Ga.	(2.6)	1"	(25.4)	1.33	(1.98)
B44M	14 Ga.	(1.9)	1"	(25.4)	0.98	(1.46)
B52M	12 Ga.	(2.6)	1 3/16"	(20.6)	1.16	(1.72)
B54M	14 Ga.	(1.9)	1 3/16"	(20.6)	.89	(1.32)

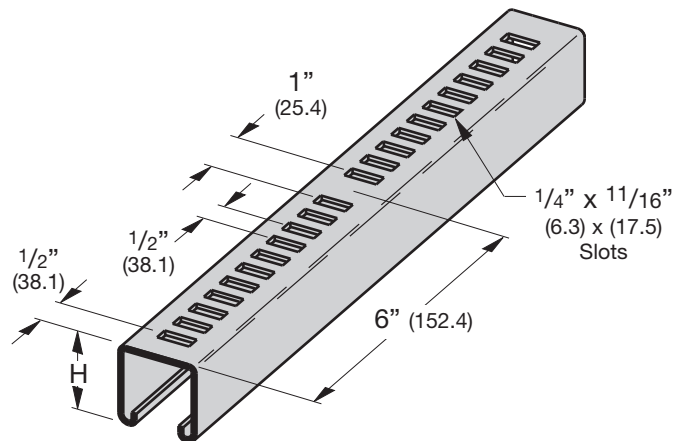

B22H25 THRU B56H25 H25 TYPE CHANNEL

• For beam loads use 90% of Channel Loading Chart

Part No.	Thickness		Height H		Weight	
	In.	mm	In.	mm	Lbs./Ft.	kg/m
B22H25	12 Ga.	(2.6)	1 5/8"	(41.3)	1.85	(2.75)
B24H25	14 Ga.	(1.9)	1 5/8"	(41.3)	1.36	(2.02)
B26H25	16 Ga.	(1.5)	1 5/8"	(41.3)	1.09	(1.62)
B32H25	12 Ga.	(2.6)	1 3/8"	(34.9)	1.65	(2.45)
B42H25	12 Ga.	(2.6)	1"	(25.4)	1.39	(2.07)
B52H25	12 Ga.	(2.6)	1 3/16"	(20.6)	1.22	(1.81)
B54H25	14 Ga.	(1.9)	1 3/16"	(20.6)	.93	(1.38)
B56H25	16 Ga.	(1.5)	1 3/16"	(20.6)	.82	(1.22)

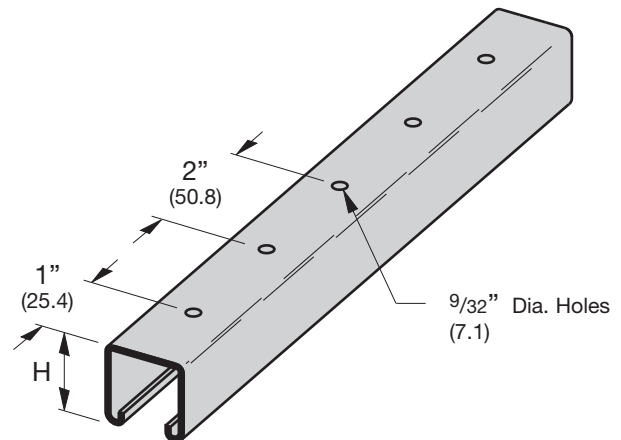

Reference page 14 for general fitting and standard finish specifications.

Channel Nuts & Hardware

Channel Nuts

Channel nuts are one of the main components of our metal framing system. It is designed to provide essential gripping power and ease during installation. Channel nuts are press formed, machined and hardened from steel which meets the requirements of ASTM A108 or ASTM A36 for our larger sizes.

Bolts, Screws, and Nuts

All bolts, screws and nuts meet the physical and chemical requirements of ASTM A307, SAE J429 or ASTM A563, and have unified inch screw threads (coarse, UNC). ISO metric threads are also available on special request.

Recommended Torque

Bolt Size	1/4"-20	5/16"-18	3/8"-16	1/2"-13
Foot/Lbs.	6	11	19	50
Nm	8	15	26	68

Bolt Size	M6x1	M8 x1.25	M10 x 1.5	M12x1.75
Nm	12	17	36	62
Foot/Lbs.	9	13	27	46

Materials & Finishes*

Finish Code	Finish	Specification
PLN	Plain	ASTM A108/A307 Gr. A, ASTM A563, SAE J429
ZN	Electro-Plated Zinc	ASTM B633 SC1 Type III
CZ	Chromium Zinc	ASTM F1136 Gr. 3
HDG	Hot-Dipped Galvanized	ASTM A153
SS6	Stainless Steel Type 316	MPIF 35/ASTM F593
AL	Aluminum	ASTM F468 S4

*Unless otherwise noted.

Note: Channel nuts are not available in HDG, Aluminum, or Stainless Steel Type 304

Metric

Metric dimensions are shown in parentheses. Unless noted, all metric dimensions are in millimeters.



Channel Nuts & Hardware

STANDARD CHANNEL NUTS

Numbering Example:

N 7 25 (*) WO

Nut Type
 N = Standard Nut
 TN = Twirl Nut
 SN = Stud Nut
 STN = Stud Twirl Nut
 NW = Combo Nut Washer

Channel Type
 7 = Tall Channels
 B11
 B12
 2 = Medium Channels
 B22
 B24
 B26
 B32
 5 = Short Channels
 B42
 B52
 B54
 B56

Thread Size
 21 = #8-32
 22 = #10-24
 27 = #10-32
 24 = 1/4-20
 23 = 5/16-18
 28 = 3/8-16
 26 = 7/16-14
 25 = 1/2-13
 55 = 5/8-11
 75 = 3/4-10
 78 = 7/8-9

Stud Length
 * = Specify Length of stud below for Stud Nut or Twirl Stud Nuts
 3/4 = 3/4"
 1 = 1"
 1 1/4 = 1 1/4"
 1 1/2 = 1 1/2"

Suffix
 WO = Without Spring
 ** = Twirl Nuts or nuts with springs have blank suffix

METRIC CHANNEL NUTS

Numbering Example: **BMS 6 M**

Nut Type
 BMS = Spring Nut
 BMS-D = Spring Nut (1/2" thick)
 BMT = Twirl Nut
 BMT-D = Twirl Nut (1/2" thick)
 BMM = Spring Nut (Mini channel)

Metric Thread Size
 3 = M3.5
 4 = M4
 5 = M5
 6 = M6
 8 = M8
 10 = M10
 12 = M12

Suffix
 S = Short Spring
 M = Medium Spring
 L = Long Spring
 * = Twirl Nuts and nuts without springs have blank suffix

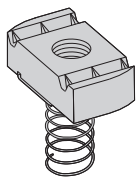

SPRING NUT

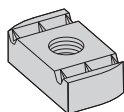

NUT WITHOUT SPRING

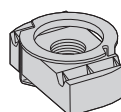

TWIRL-NUT™

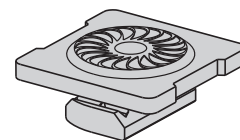

COMBO NUT WASHER

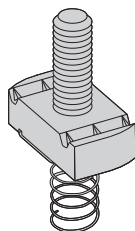

STUD NUT WITH SPRING

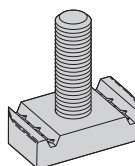

STUD NUT WITHOUT SPRING

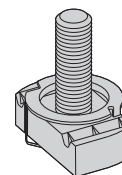

TWIRL STUD NUT

Reference page 44 for general fitting and standard finish specifications.

Channel Nuts

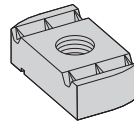

Note: See page 50 for resistance to slip & page 51 for pull-out strength.

NUT WITHOUT SPRING

Part No.	Thread Size	Fits Channel Sizes	Nut Thickness		Wt./C	
					Lbs.	kg
N221WO	#8-32	All sizes except B62 & B72	1/4"	(6.3)	7.0	(3.17)
N227WO	#10-32	All sizes except B62 & B72	1/4"	(6.3)	7.0	(3.17)
N222WO	#10-24	All sizes except B62 & B72	1/4"	(6.3)	7.0	(3.17)
N224WO	1/4-20	All sizes except B62 & B72	1/4"	(6.3)	6.7	(3.04)
N223WO	5/16-18	All sizes except B62 & B72	1/4"	(6.3)	6.7	(3.04)
N228WO	3/8-16	All sizes except B62 & B72	3/8"	(9.5)	9.3	(4.22)
N226WO	7/16-14	All sizes except B62 & B72	3/8"	(9.5)	8.8	(3.99)
N225WO	1/2-13	B11, B12, B22, B24, B26, B32	1/2"	(12.7)	11.6	(5.26)
N525WO	1/2-13	B42, B52, B54, B56	3/8"	(9.5)	8.8	(3.99)
N255WO	5/8-11	B11, B12, B22, B24, B26, B32	1/2"	(12.7)	16.4	(7.44)
N555WO	5/8-11	B42, B52, B54, B56	3/8"	(9.5)	10.2	(4.62)
N275WO	3/4-10	B11, B12, B22, B24, B26, B32	1/2"	(12.7)	14.5	(6.58)
N575WO	3/4-10	B42, B52, B54, B56	3/8"	(9.5)	8.8	(3.99)
N278WO	7/8-9	B11, B12, B22, B24, B26, B32	1/2"	(12.7)	12.5	(5.67)
Metric Threads						
BMS-6	M6 x 1	All sizes except B62 & B72	1/4"	(6.3)	6.9	(3.13)
BMS-8	M8 x 1.25	All sizes except B62 & B72	1/4"	(6.3)	6.7	(3.04)
BMS-10	M10 x 1.5	All sizes except B62 & B72	3/8"	(9.5)	9.6	(4.35)
BMS-12	M12 x 1.75	All sizes except B62 & B72	3/8"	(9.5)	9.2	(4.17)
BMS-D-12	M12 x 1.75	B11, B12, B22, B24, B26, B32	1/2"	(12.7)	12.2	(5.53)

Note: For mini channel nut information see page 203.

Reference page 44 for general fitting and standard finish specifications.

Note: See page 50 for resistance to slip & page 51 for pull-out strength.

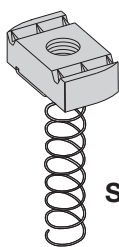

700 Series

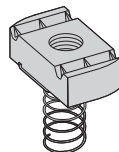

200 Series

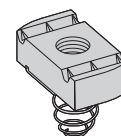

500 Series

SPRING NUT

Part No.	Thread Size	Fits Channel Sizes	Nut Thickness		Wt./C	
					Lbs.	kg
N721	#8-32	B11 & B12	1/4"	(6.3)	7.0	(3.17)
N221	#8-32	B22, B24, B26, B32	1/4"	(6.3)	7.0	(3.17)
N521	#8-32	B42, B52, B54, B56	1/4"	(6.3)	7.0	(3.17)
N727	#10-32	B11 & B12	1/4"	(6.3)	7.0	(3.17)
N227	#10-32	B22, B24, B26, B32	1/4"	(6.3)	7.0	(3.17)
N527	#10-32	B42, B52, B54, B56	1/4"	(6.3)	7.0	(3.17)
N722	#10-24	B11 & B12	1/4"	(6.3)	7.0	(3.17)
N222	#10-24	B22, B24, B26, B32	1/4"	(6.3)	7.0	(3.17)
N522	#10-24	B42, B52, B54, B56	1/4"	(6.3)	7.0	(3.17)
N724	1/4-20	B11 & B12	1/4"	(6.3)	6.7	(3.04)
N224	1/4-20	B22, B24, B26, B32	1/4"	(6.3)	6.7	(3.04)
N524	1/4-20	B42, B52, B54, B56	1/4"	(6.3)	6.7	(3.04)
N723	5/16-18	B11 & B12	1/4"	(6.3)	6.7	(3.04)
N223	5/16-18	B22, B24, B26, B32	1/4"	(6.3)	6.7	(3.04)
N523	5/16-18	B42, B52, B54, B56	1/4"	(6.3)	6.7	(3.04)
N728	3/8-16	B11 & B12	3/8"	(9.5)	9.3	(4.22)
N228	3/8-16	B22, B24, B26, B32	3/8"	(9.5)	9.3	(4.22)
N528	3/8-16	B42, B52, B54, B56	3/8"	(9.5)	9.3	(4.22)
N726	7/16-14	B11 & B12	3/8"	(9.5)	8.8	(3.99)
N226	7/16-14	B22, B24, B26, B32	3/8"	(9.5)	8.8	(3.99)
N526	7/16-14	B42, B52, B54, B56	3/8"	(9.5)	8.8	(3.99)
N725	1/2-13	B11 & B12	1/2"	(12.7)	11.6	(5.26)
N225	1/2-13	B22, B24, B26, B32	1/2"	(12.7)	11.6	(5.26)
N525	1/2-13	B42, B52, B54, B56	3/8"	(9.5)	8.8	(3.99)
N755	5/8-11	B11 & B12	1/2"	(12.7)	16.4	(7.44)
N255	5/8-11	B22, B24, B26, B32	1/2"	(12.7)	16.4	(7.44)
N555	5/8-11	B42, B52, B54, B56	3/8"	(9.5)	10.2	(4.62)
N775	3/4-10	B11 & B12	1/2"	(12.7)	14.5	(6.58)
N275	3/4-10	B22, B24, B26, B32	1/2"	(12.7)	14.5	(6.58)
N575	3/4-10	B42, B52, B54, B56	3/8"	(9.5)	8.8	(3.99)
N778	7/8-9	B11 & B12	1/2"	(12.7)	12.5	(5.67)
N278	7/8-9	B22, B24, B26, B32	1/2"	(12.7)	12.5	(5.67)
Metric Threads						
BMS-6L	M6 x 1	B11 & B12	1/4"	(6.3)	6.9	(3.13)
BMS-6M	M6 x 1	B22, B24, B26, B32	1/4"	(6.3)	6.9	(3.13)
BMS-6S	M6 x 1	B42, B52, B54, B56	1/4"	(6.3)	6.9	(3.13)
BMS-8L	M8 x 1.25	B11 & B12	1/4"	(6.3)	6.7	(3.04)
BMS-8M	M8 x 1.25	B22, B24, B26, B32	1/4"	(6.3)	6.7	(3.04)
BMS-8S	M8 x 1.25	B42, B52, B54, B56	1/4"	(6.3)	6.7	(3.04)
BMS-10L	M10 x 1.5	B11 & B12	3/8"	(9.5)	9.6	(4.35)
BMS-10M	M10 x 1.5	B22, B24, B26, B32	3/8"	(9.5)	9.6	(4.35)
BMS-10S	M10 x 1.5	B42, B52, B54, B56	3/8"	(9.5)	9.6	(4.35)
BMS-12M	M12 x 1.75	B22, B24, B26, B32	3/8"	(9.5)	9.2	(4.17)
BMS-12S	M12 x 1.75	B42, B52, B54, B56	3/8"	(9.5)	9.2	(4.17)
BMS-D-12L	M12 x 1.75	B11 & B12	1/2"	(12.7)	12.2	(5.53)
BMS-D-12M	M12 x 1.75	B22, B24, B26, B32	1/2"	(12.7)	12.2	(5.53)

Note: For mini channel nut information see page 203.

Reference page 44 for general fitting and standard finish specifications.

Channel Nuts

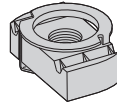

Note: See page 50 for resistance to slip & page 51 for pull-out strength.

TWIRL-NUT™

Part No.	Thread Size	Fits Channel Sizes	Nut Thickness		Wt./C		
					Lbs.	kg	
TN221	#8-32	All sizes except B62 & B72	1/4"	(6.3)	7.0	(3.17)	
TN227	#10-32	All sizes except B62 & B72	1/4"	(6.3)	7.0	(3.17)	
TN222	#10-24	All sizes except B62 & B72	1/4"	(6.3)	7.0	(3.17)	
TN224	1/4-20	All sizes except B62 & B72	1/4"	(6.3)	6.7	(3.04)	
TN223	5/16-18	All sizes except B62 & B72	1/4"	(6.3)	6.7	(3.04)	
TN228	3/8-16	All sizes except B62 & B72	3/8"	(9.5)	9.3	(4.22)	
TN226	7/16-14	All sizes except B62 & B72	3/8"	(9.5)	8.8	(3.99)	
TN225	1/2-13	B11, B12, B22, B24, B26, B32	1/2"	(12.7)	11.6	(5.26)	
TN525	1/2-13	B42, B52, B54, B56	3/8"	(9.5)	8.8	(3.99)	
TN255	5/8-11	B11, B12, B22, B24, B26, B32	1/2"	(12.7)	11.0	(4.99)	
Metric Threads	BMT-6	M6 x 1	All sizes except B62 & B72	1/4"	(6.3)	6.9	(3.13)
	BMT-8	M8 x 1.25	All sizes except B62 & B72	1/4"	(6.3)	6.7	(3.04)
	BMT-10	M10 x 1.5	All sizes except B62 & B72	3/8"	(9.5)	9.6	(4.35)
	BMT-12	M12 x 1.75	All sizes except B62 & B72	3/8"	(9.5)	9.2	(4.17)
	BMT-D-12	M12 x 1.75	B11, B12, B22, B24, B26, B32	1/2"	(12.7)	12.2	(5.53)

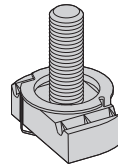

Note: See page 50 for resistance to slip & page 51 for pull-out strength.

TWIRL STUD NUT

Part No.	Thread Size	Fits Channel Sizes	Nut Thickness		Wt./C	
					Lbs.	kg
STN224-*	1/4-20	All sizes except B62 & B72	1/4"	(6.3)	8.1	(3.66)
STN228-*	3/8-16	All sizes except B62 & B72	3/8"	(9.5)	12.9	(5.85)
STN225-*	1/2-13	B11, B12, B22, B24, B26, B32	1/2"	(12.7)	18.2	(8.23)
STN525-*	1/2-13	B42, B52, B54, B56	3/8"	(9.5)	15.4	(6.96)

*Note: Add stud length in inches (3/4, 1, 1 1/4, 1 1/2)

Note: See page 50 for resistance to slip & page 51 for pull-out strength.

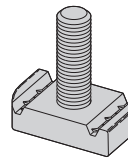

STUD NUT WITHOUT SPRING

Part No.	Thread Size	Fits Channel Sizes	Nut Thickness		Wt./C	
					Lbs.	kg
SN224-*WO	1/4-20	All sizes except B62 & B72	1/4"	(6.3)	8.1	(3.66)
SN228-*WO	3/8-16	All sizes except B62 & B72	3/8"	(9.5)	12.9	(5.85)
SN225-*WO	1/2-13	B11, B12, B22, B24, B26, B32	1/2"	(12.7)	18.2	(8.23)
SN525-*WO	1/2-13	B42, B52, B54, B56	3/8"	(9.5)	15.4	(6.96)

*Note: Add stud length in inches (3/4, 1, 1 1/4, 1 1/2)

Reference page 44 for general fitting and standard finish specifications.

Note: See page 50 for resistance to slip & page 51 for pull-out strength.

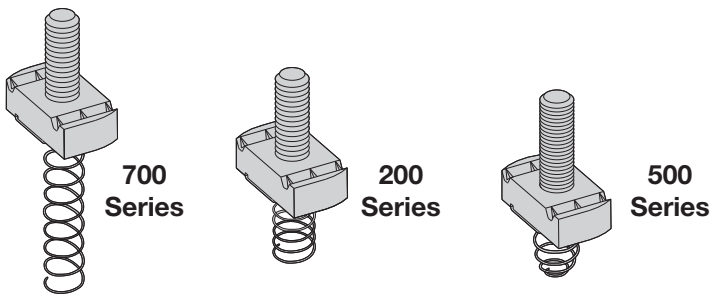

STUD NUT WITH SPRING

Part No.	Thread Size	Fits Channel Sizes	Nut Thickness		Wt./C	
					Lbs.	kg
SN724-*	1/4-20	B11 & B12	1/4"	(6.3)	8.1	(3.66)
SN224-*	1/4-20	B22, B24, B26, B32	1/4"	(6.3)	8.1	(3.66)
SN524-*	1/4-20	B42, B52, B54, B56	1/4"	(6.3)	8.1	(3.66)
SN728-*	3/8-16	B11 & B12	3/8"	(9.5)	12.9	(5.85)
SN228-*	3/8-16	B22, B24, B26, B32	3/8"	(9.5)	12.9	(5.85)
SN528-*	3/8-16	B42, B52, B54, B56	3/8"	(9.5)	12.9	(5.85)
SN725-*	1/2-13	B11 & B12	1/2"	(12.7)	18.2	(8.23)
SN225-*	1/2-13	B22, B24, B26, B32	1/2"	(12.7)	18.2	(8.23)
SN525-*	1/2-13	B42, B52, B54, B56	3/8"	(9.5)	15.4	(6.96)

*Note: Add stud length in inches (3/4, 1, 1 1/4, 1 1/2)

- Finish: Electrodeposited zinc ASTM B633 SC1
- Available in 316 stainless steel - add SS6 to part number
- To lock combo nut washer in place a nex nut (sold separately) is required

Note: See page 50 for resistance to slip & page 51 for pull-out strength.

Patent Number
7,604,444

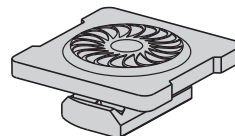

COMBO NUT WASHER

Part No.	Thread Size	Fits Channel Sizes	Nut Thickness		Wt./C	
					Lbs.	kg
NW524	1/4-20	All Channel Sizes	1/4"	(6.3)	11.9	(5.40)
NW528	3/8-16	All Channel Sizes	3/8"	(9.5)	13.8	(6.26)
NW525	1/2-13	All Channel Sizes	3/8"	(9.5)	13.1	(5.94)
NWM6	M6	All Channel Sizes	1/4"	(6.3)	16.6	(7.50)
NWM8	M8	All Channel Sizes	1/4"	(6.3)	15.4	(7.00)
NWM10	M10	All Channel Sizes	3/8"	(9.5)	18.9	(8.57)
NWM12	M12	All Channel Sizes	3/8"	(9.5)	17.7	(8.00)

Reference page 44 for general fitting and standard finish specifications.

Channel Nuts

RESISTANCE TO SLIP

- With Safety Factor of 3

Thread Size	Nut Part Numbers	Resistance to Slip					
		12 ga. Channel		14 ga. Channel		16 ga. Channel	
		Lbs.	N	Lbs.	N	Lbs.	N
#8-32	N221, N221WO, N521, N721, TN221	50	220	50	220	50	220
#10-24	N222, N222WO, N522, N722, TN222	100	440	100	440	100	440
#10-32	N227, N227WO, N527, N727, TN227	100	440	100	440	100	440
1/4"-20	NW524*, N224, N224WO, N524, N724, TN224, STN224, SN224WO, SN224, SN524, SN724	300	1330	300	1330	300	1330
5/16"-18	N223, N223WO, N523, N723, TN223	450	2000	450	2000	450	2000
3/8"-16	NW528*, N228, N228WO, N528, N728 TN228, STN228, SN228WO, SN228, SN528, SN728	800	3560	600	2670	600	2670
7/16"-14	N226, N226WO, N526, N726, TN226	1000	4450	800	3560	800	3560
1/2"-13	N225, N225WO, N725, TN225, STN225, SN225WO, SN225, SN725	1500	6670	1000	4450	1000	4450
	NW525*, N525, N525WO, TN525, STN525, SN525WO, SN525	1500	6670	1000	4450	1000	4450
5/8"-11	N255, N255WO, N755, TN255	1500	6670	1000	4450	1000	4450
	N555, N555WO	1500	6670	1000	4450	1000	4450
3/4"-10	N275, N275WO, N775	1500	6670	1000	4450	1000	4450
	N575, N575WO	1500	6670	1000	4450	1000	4450
7/8"-9	N278, N278WO, N778	1500	6670	1000	4450	1000	4450
M6 x 1	BMS-6, BMS-6L, BMS-6M, BMS-6S, BMT-6	300	1330	300	1330	300	1330
M8 x 1.25	BMS-8, BMS-8L, BMS-8M, BMS-8S, BMT-8	450	2000	450	2000	450	2000
M10 x 1.50	BMS-10, BMS-10L, BMS-10M, BMS-10S, BMT-20	800	3560	600	2760	600	2760
M12 x 1.75	BMS-D-12, BMS-D-12L, BMS-D-12M, BMT-D-12	1500	6670	1000	4450	1000	4450
	BMS-12, BMS-12M, BMS-12S, BMT-12	1500	6670	1000	4450	1000	4450

* Combo Nut Washer (see page 49)

Note: When using stainless steel, reduce slip load by 50% due to hardness of material.

Resistance to Slip of Channel Nut

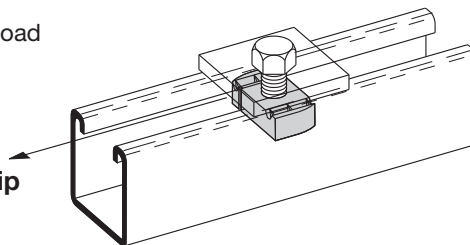

Note: For mini channel nut information see page 203.

Reference page 44 for general fitting and standard finish specifications.

PULL-OUT STRENGTH

- With Safety Factor of 3
- Maximum pullout strength for B11 & B12 channels is limited to 1500 lbs. (6670 N).

Thread Size	Nut Part Numbers	Pull-Out Strength					
		12 ga. Channel		14 ga. Channel		16 ga. Channel	
		Lbs.	N	Lbs.	N	Lbs.	N
#8-32	N221, N221WO, N521, N721, TN221	200	890	200	890	200	890
#10-24	N222, N222WO, N522, N722, TN222	250	1110	250	1110	250	1110
#10-32	N227, N227WO, N527, N727, TN227	250	1110	250	1110	250	1110
1/4"-20	NW524*, N224, N224WO, N524, N724, TN224, STN224, SN224WO, SN224, SN524, SN724	450	2000	450	2000	450	2000
5/16"-18	N223, N223WO, N523, N723, TN223	750	3330	750	3330	750	3330
3/8"-16	NW528*, N228, N228WO, N528, N728, TN228, STN228, SN228WO, SN228, SN528, SN728	1100	4890	1000	4450	1000	4450
7/16"-14	N226, N226WO, N526, N726, TN226	1500	6670	1200	5340	1000	4450
1/2"-13	N225, N225WO, N725, TN225, STN225, SN225WO, SN225, SN725	2000	8900	1400	6230	1000	4450
	NW525*, N525, N525WO, TN525, STN525, SN525WO, SN525	1500	6670	1400	6230	1000	4450
5/8"-11	N255, N255WO, N755, TN255	2000	8900	1400	6230	1000	4450
	N555, N555WO	1500	6670	1400	6230	1000	4450
3/4"-10	N275, N275WO, N775	2000	8900	1400	6230	1000	4450
	N575, N575WO	1500	6670	1400	6230	1000	4450
7/8"-9	N278, N278WO, N778	1500	6670	1400	6230	1000	4450
M6 x 1	BMS-6, BMS-6L, BMS-6M, BMS-6S, BMT-6	450	2000	450	2000	450	2000
M8 x 1.25	BMS-8, BMS-8L, BMS-8M, BMS-8S, BMT-8	750	3330	750	3330	750	3330
M10 x 1.50	BMS-10, BMS-10L, BMS-10M, BMS-10S, BMT-20	1100	4890	1000	4450	1000	4450
M12 x 1.75	BMS-D-12, BMS-D-12L, BMS-D-12M, BMT-D-12	2000	8900	1400	6230	1000	4450
	BMS-12, BMS-12M, BMS-12S, BMT-12	1500	6670	1400	6230	1000	4450

 Channel Nuts & Hardware
Metric Threads

* Combo Nut Washer (see page 49)
 Note: When using stainless steel, reduce slip load by 50% due to hardness of material.

Note: For mini channel nut information see page 203.

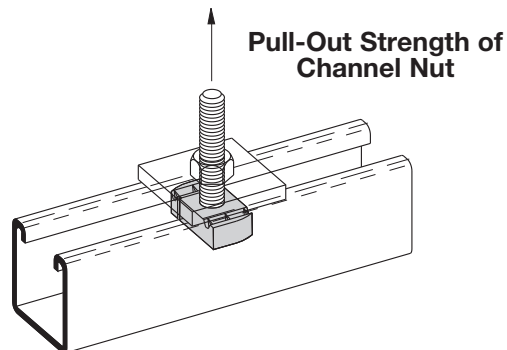

Reference page 44 for general fitting and standard finish specifications.

Hardware

DCN 3/8 DOUBLE CONVEYOR NUT

- Recommended torque - 19 ft./Lbs.
- Allowable slip loading - 700 Lbs.(3.11kN)
- Safety Factor of 3
- Material: ASTM 1011SS Gr. 33
- Finish: Electrodeposited zinc ASTM B633 SC1
- Strut ordered separately

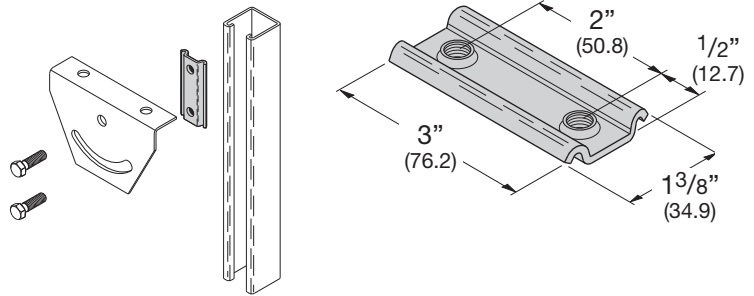

B501 SERIES U-BOLT

- Designed for use with Rigid Conduit or Iron Pipe
- Dimension "C" is dependent on the type of pipe or conduit supported and is a reference only

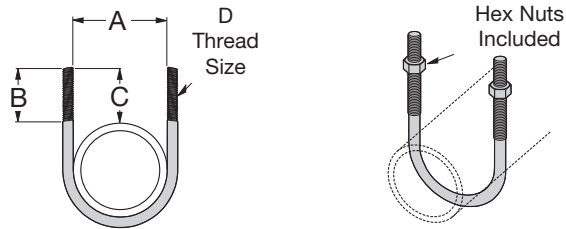

Part No.	A		B		C		D	Design Load		Wt./C	
	Lbs.	kN	Lbs.	kN	Lbs.	kN		Lbs.	kN	Lbs.	kg
B501-1/2	15/16"	(23.8)	13/4"	(44.4)	1 1/2"	(38.1)	5/16"-18	600	(2.67)	12	(5.4)
B501-3/4	1 1/8"	(28.6)	13/4"	(44.4)	1 5/8"	(41.3)	5/16"-18	600	(2.67)	13	(5.9)
B501-1	1 3/8"	(29.9)	1 7/8"	(47.6)	1 5/8"	(41.3)	5/16"-18	900	(4.00)	14	(6.3)
B501-1 1/4	1 23/32"	(43.6)	1 3/4"	(44.4)	1 15/32"	(37.3)	5/16"-18	900	(4.00)	15	(6.8)
B501-1 1/2	2"	(50.8)	1 3/4"	(44.4)	1 7/16"	(36.5)	5/16"-18	900	(4.00)	16	(7.2)
B501-2	2 7/16"	(61.9)	2 1/16"	(52.4)	1 7/8"	(47.6)	3/8"-16	1200	(5.34)	27	(12.2)
B501-2 1/2	2 15/16"	(74.6)	2 1/16"	(52.4)	1 13/16"	(46.0)	3/8"-16	1200	(5.34)	32	(14.5)
B501-3	3 9/16"	(90.5)	2"	(50.8)	1 3/4"	(44.4)	3/8"-16	1800	(8.00)	36	(16.3)
B501-3 1/2	4 3/32"	(94.6)	2"	(50.8)	1 23/32"	(43.6)	3/8"-16	1800	(8.00)	38	(17.2)
B501-4	4 19/32"	(116.7)	2 1/4"	(57.1)	1 21/32"	(50.0)	3/8"-16	1800	(8.00)	42	(19.0)
B501-5	5 21/32"	(143.6)	2 1/4"	(57.1)	2"	(50.8)	1/2"-13	2400	(10.70)	92	(41.7)
B501-6	6 3/4"	(171.4)	2 5/8"	(66.7)	2 3/8"	(60.3)	5/8"-11	2400	(10.70)	176	(79.8)
B501-8	8 3/4"	(222.2)	2 5/8"	(66.7)	2 3/8"	(60.3)	5/8"-11	2400	(10.70)	191	(86.6)

B500 SERIES SQUARE U-BOLT

- Includes:
 - 1 pc. U-Bolt only
 - 2 pcs. 3/8"-16 Hex Nuts
- Additional sizes available
- Standard finish: ZN, SS4

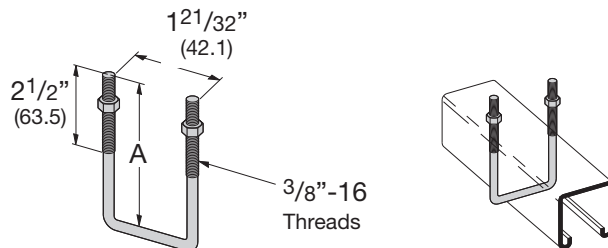

Part No.	A		Channel Size	Wt./C	
	Lbs.	kg		Lbs.	kg
B500-3-3/8	3 3/8"	(85.7)	1 5/8" x 1 5/8"	25	(11.3)
B500-5	5"	(127.0)	3 1/4" x 1 5/8"	33	(14.9)

Reference page 44 for general fitting and standard finish specifications.

HHCS HEX HEAD CAP SCREWS

- Standard finish: Zinc-Plated, Stainless Steel

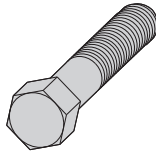

Part No.	Wt./C	
	Lbs.	kg
1/4" x 1/2" HHCS	1.3	(.59)
1/4" x 3/4" HHCS	1.4	(.63)
1/4" x 1" HHCS	1.7	(.77)
1/4" x 1 1/4" HHCS	2.1	(.95)
1/4" x 1 1/2" HHCS	2.4	(1.09)
5/16" x 1" HHCS	2.8	(1.27)
5/16" x 1 1/4" HHCS	3.2	(1.45)
5/16" x 1 1/2" HHCS	3.8	(1.72)
3/8" x 3/4" HHCS	3.4	(1.54)
3/8" x 1" HHCS	4.1	(1.86)
3/8" x 1 1/4" HHCS	4.7	(2.13)
3/8" x 1 1/2" HHCS	5.2	(2.36)
3/8" x 1 3/4" HHCS	5.9	(2.67)
3/8" x 2" HHCS	7.0	(3.17)
3/8" x 2 1/4" HHCS	7.8	(3.54)
3/8" x 2 1/2" HHCS	8.5	(3.85)
1/2" x 7/8" HHCS	8.0	(3.63)
1/2" x 1" HHCS	8.4	(3.81)
1/2" x 1 1/4" HHCS	9.2	(4.17)
1/2" x 1 1/2" HHCS	10.1	(4.58)
1/2" x 1 3/4" HHCS	12.0	(5.44)
1/2" x 2" HHCS	13.2	(5.99)
1/2" x 2 1/2" HHCS	16.0	(7.26)

SRHMS SLOTTED ROUND HEAD MACHINE SCREWS

- Standard finish: Zinc-Plated

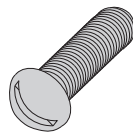

Part No.	Wt./C	
	Lbs.	kg
1/4" x 1/2" SRHMS	.9	(.41)
1/4" x 3/4" SRHMS	1.2	(.54)
1/4" x 1" SRHMS	1.5	(.68)
1/4" x 1 1/4" SRHMS	1.7	(.77)
1/4" x 1 1/2" SRHMS	1.9	(.86)
5/16" x 1" SRHMS	2.5	(1.13)
5/16" x 1 1/4" SRHMS	2.9	(1.31)
5/16" x 1 1/2" SRHMS	3.3	(1.49)
3/8" x 1" SRHMS	4.0	(1.81)
3/8" x 1 1/4" SRHMS	4.5	(2.04)
3/8" x 1 1/2" SRHMS	5.1	(2.31)
3/8" x 2" SRHMS	6.3	(2.86)
3/8" x 2 1/4" SRHMS	7.1	(3.22)
3/8" x 2 1/2" SRHMS	7.7	(3.49)

SFHMS SLOTTED FLAT HEAD MACHINE SCREWS

- Standard finish: Zinc-Plated

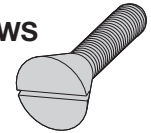

Part No.	Wt./C	
	Lbs.	kg
1/4" x 1/2" SFHMS	1.1	(.50)
1/4" x 5/8" SFHMS	1.2	(.54)
1/4" x 3/4" SFHMS	1.4	(.63)
5/16" x 1" SFHMS	2.8	(1.27)
3/8" x 1 1/2" SFHMS	5.6	(2.54)
3/8" x 2" SFHMS	6.7	(3.04)
3/8" x 2 1/4" SFHMS	7.3	(3.31)
3/8" x 2 1/2" SFHMS	7.9	(3.58)
1/2" x 1" SFHMS	5.9	(2.67)
1/2" x 1 1/4" SFHMS	7.0	(3.17)
1/2" x 1 1/2" SFHMS	8.3	(3.76)
1/2" x 2 1/2" SFHMS	13.8	(6.26)

SHHMS SLOTTED (COMBINATION RECESS) HEX HEAD MACHINE SCREWS

- Standard finish: Zinc-Plated, Stainless Steel

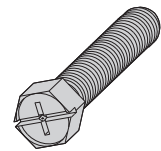

Part No.	Wt./C	
	Lbs.	kg
1/4" x 3/4" SHHMS	1.2	(.54)
1/4" x 1" SHHMS	1.5	(.68)
1/4" x 1 1/4" SHHMS	1.8	(.80)
1/4" x 1 1/2" SHHMS	2.0	(.91)
5/16" x 1" SHHMS	2.6	(1.18)
5/16" x 1 1/4" SHHMS	3.1	(1.40)
5/16" x 1 1/2" SHHMS	3.4	(1.54)
3/8" x 1 1/4" SHHMS	4.6	(2.08)
3/8" x 1 1/2" SHHMS	5.3	(2.40)

CNPSS SQUARE HEAD CONE POINT SET SCREWS

- Standard finish: ZN

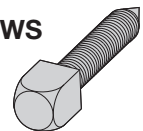

Part No.	Wt./C	
	Lbs.	kg
3/8" x 1 1/2" CNPSS	4.7	(2.13)
3/8" x 2" CNPSS	6.0	(2.72)
1/2" x 1 1/2" CNPSS	9.2	(4.17)
1/2" x 2" CNPSS	11.4	(5.17)
1/2" x 2 1/2" CNPSS	13.7	(6.21)
5/8" x 2" CNPSS	19.0	(8.62)
5/8" x 2 1/2" CNPSS	22.6	(10.25)

Reference page 44 for general fitting and standard finish specifications.

B446A SWIVEL HANGER (FEMALE ONLY)

- Design Load:
(³/₈)-610 Lbs. (2.71 kN)
(¹/₂)-1130 Lbs. (5.02 kN)
- Safety Factor of 3
- Standard finish: ZN

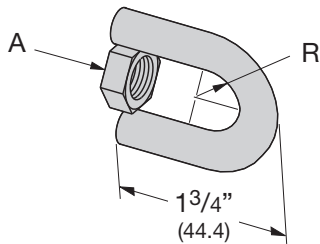

Part No.	A	R	Wt./C	
			Lbs.	kg
B446A- ³ / ₈	³ / ₈ "-16 HN	⁹ / ₃₂ " (7.1)	13	(5.9)
B446A- ¹ / ₂	¹ / ₂ "-13 HN	³ / ₈ " (9.5)	15	(6.8)

B446B SWIVEL HANGER (MALE ONLY)

- Design Load:
(³/₈)-610 Lbs. (2.71 kN)
(¹/₂)-1130 Lbs. (5.02 kN)
- Safety Factor of 3
- Standard finish: ZN

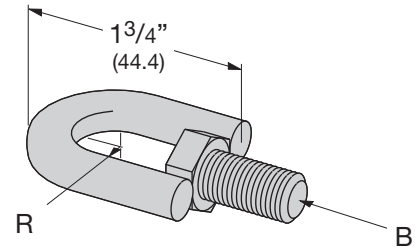

Part No.	A	R	Wt./C	
			Lbs.	kg
B446B- ³ / ₈	³ / ₈ "-16 HHCS	⁹ / ₃₂ " (7.1)	16	(7.2)
B446B- ¹ / ₂	¹ / ₂ "-13 HHCS	³ / ₈ " (9.5)	20	(9.1)

B446C SWIVEL HANGER (FEMALE-FEMALE)

- Design Load:
(³/₈)-610 Lbs. (2.71 kN)
(¹/₂)-1130 Lbs. (5.02 kN)
- Safety Factor of 3
- Standard finish: ZN

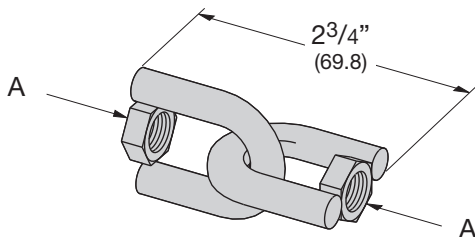

Part No.	A	Wt./C	
		Lbs.	kg
B446C- ³ / ₈	³ / ₈ "-16 HN	26	(11.8)
B446C- ¹ / ₂	¹ / ₂ "-13 HN	31	(14.0)

B446 SWIVEL HANGER (FEMALE-MALE)

- Design Load:
(³/₈)-610 Lbs. (2.71 kN)
(¹/₂)-1130 Lbs. (5.02 kN)
- Safety Factor of 3
- Standard finish: ZN

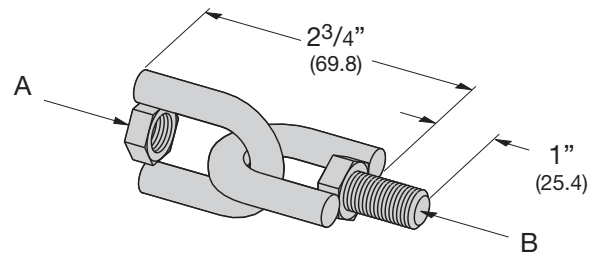

Part No.	A	B	Wt./C	
			Lbs.	kg
B446- ³ / ₈	³ / ₈ "-16 HN	³ / ₈ "-16 HHCS	28	(12.7)
B446- ¹ / ₂	¹ / ₂ "-13 HN	¹ / ₂ "-13 HHCS	36	(16.3)

Reference page 44 for general fitting and standard finish specifications.

B617 SHOULDER BOLT

- Standard finish: ZN
- Wt./C 6 Lbs. (2.7 kg)

$\frac{3}{8}$ "-16 Thread Size

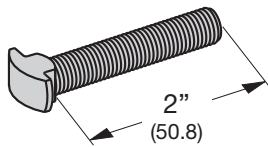
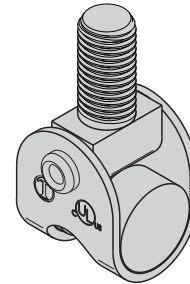

Fig. 75 SWIVEL ATTACHMENT

- Standard finish: ZN
- Sized for $\frac{3}{8}$ "-16 threaded rods
- UL Listed to support up to 4" Pipe per NFPA 13
- Wt./C 13 Lbs. (5.9 kg)



HN HEX NUTS

- Standard finish: Zinc-Plated, Stainless Steel

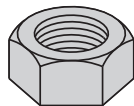

Part No.	Wt./C	
	Lbs.	kg
1/4" HN	.7	(.32)
5/16" HN	1.0	(.45)
3/8" HN	1.5	(.68)
1/2" HN	3.6	(1.63)
5/8" HN	7.2	(3.26)
3/4" HN	11.1	(5.03)
7/8" HN	17.9	(8.12)
1" HN	27.2	(12.34)

MSQN MACHINE SQUARE NUT

- For use with B755 Beam Clamp
- Standard finish: Zinc-Plated

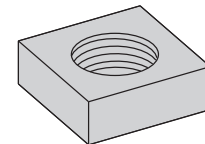

Part No.	Wt./C	
	Lbs.	kg
MSQN 1/4"	.6	(.27)
MSQN 5/16"	1.2	(.54)
MSQN 3/8"	1.8	(.81)

SQN SQUARE NUTS

- Standard finish: Zinc-Plated

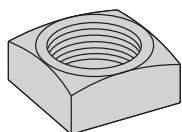

Part No.	Wt./C	
	Lbs.	kg
1/2" SQN	5.7	(2.58)
5/8" SQN	10.1	(4.58)

Reference page 44 for general fitting and standard finish specifications.

Hardware

Buzznut™

- Can be installed at any desired position on the ATR, eliminating the need to thread hex nuts up along ATR.
- Loading Safety Factor of 3.
- Torque: 6 ft./lbs (8 Nm)
- Available in Zinc Plated or 316 stainless steel.

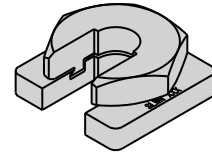

Part No.	Thread Size	Loading		Wt./C	
		Lbs.	kN	Lbs.	kg
SLWN1/4	1/4-20	240	(1.07)	14.4	(6.5)
SLWN3/8	3/8-16	730	(3.24)	15.4	(7.0)
SLWN1/2	1/2-13	1350	(6.00)	18.8	(8.5)
SLWN5/8	5/8-11	2100	(9.33)	25.4	(11.5)
SLWNM6	M6	200	(0.90)	14.1	(6.4)
SLWNM8	M8	380	(1.70)	16.3	(7.4)
SLWNM10	M10	584	(2.60)	17.2	(7.8)
SLWNM12	M12	840	(3.70)	18.9	(8.6)

FW FLAT WASHERS

- Standard finish: Zinc-Plated, Stainless Steel

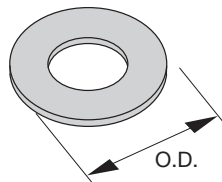

Part No.	O.D. Outside Dia.		Wt./C	
	in.	mm	Lbs.	kg
1/4" FW	47/64"	(18.7)	.7	(.32)
5/16" FW	7/8"	(22.2)	1.4	(.63)
3/8" FW	1"	(25.4)	1.7	(.77)
1/2" FW	1 3/8"	(34.9)	3.9	(1.77)
5/8" FW	1 15/32"	(37.3)	6.4	(2.90)
3/4" FW	2"	(50.8)	10.9	(4.94)
7/8" FW	2 1/4"	(57.1)	13.4	(6.08)
1" FW	2 1/2"	(63.5)	18.8	(8.53)

FFW FLAT FENDER WASHERS

- Standard finish: Zinc-Plated

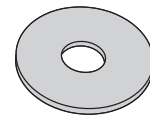

Part No.	Wt./C	
	Lbs.	kg
1/4" x 1 1/4" FFW	2.2	(1.00)
1/4" x 1 1/2" FFW	3.1	(1.40)
3/8" x 1 1/4" FFW	2.0	(.91)
3/8" x 1 1/2" FFW	3.0	(1.36)
1/2" x 2" FFW	5.4	(2.45)

LW LOCK WASHERS

- Standard finish: Zinc-Plated, Stainless Steel

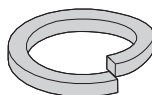

Part No.	Wt./C	
	Lbs.	kg
1/4" LW	.3	(.13)
5/16" LW	.4	(.18)
3/8" LW	.6	(.27)
1/2" LW	1.3	(.59)
5/8" LW	2.4	(1.09)
3/4" LW	3.8	(1.72)
7/8" LW	5.9	(2.67)
1" LW	8.8	(3.99)

Reference page 44 for general fitting and standard finish specifications.

SC228 HANGER ROD STIFFENER

- For $\frac{3}{8}$ " thru $\frac{5}{8}$ " ATR
- Strut ordered separately
- Standard finish: ZN
- Wt./C 21 Lbs. (9.5 kg)

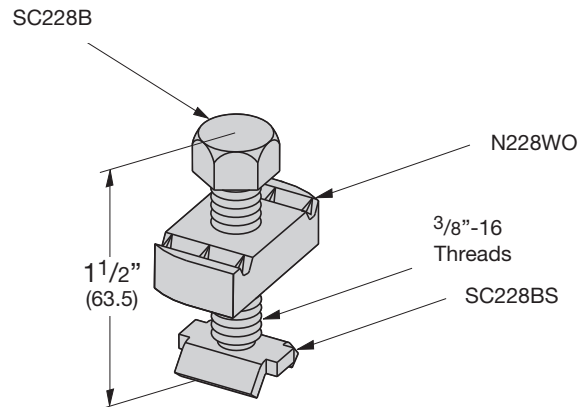
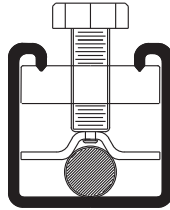

Fig. 98 ROD STIFFENER

- For $\frac{3}{8}$ " thru $\frac{7}{8}$ " ATR
- Use with 12 ga. strut only, ordered separately
- Secures channel to hanger rod for vertical seismic bracing
- Standard finish: ZN
- Wt./C 11 Lbs. (5.0 kg)

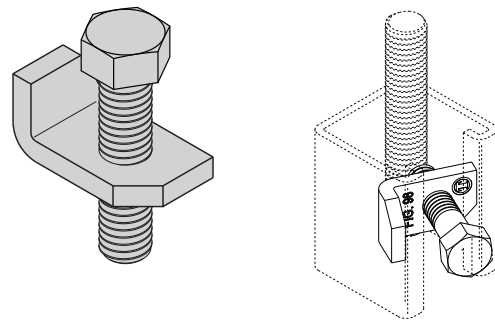
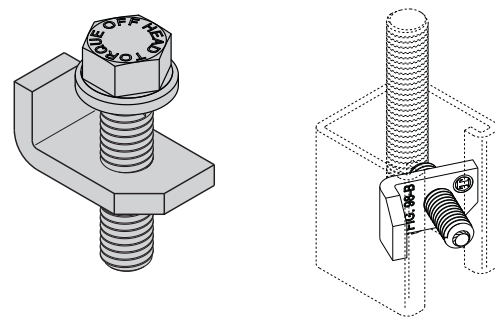

Fig. 98B ROD STIFFENER w/BREAK-OFF BOLT HEAD

- For $\frac{3}{8}$ " thru $\frac{7}{8}$ " ATR
- Use with 12 ga. strut only, ordered separately
- Secures channel to hanger rod for vertical seismic bracing
- Uses a snap-off bolt head
- Standard finish: ZN
- Wt./C 13 Lbs. (5.9 kg)



SC-UB HANGER ROD STIFFENER

- For $\frac{3}{4}$ " thru $\frac{7}{8}$ " ATR
- Strut ordered separately
- Includes: (1) B3188-1 $\frac{1}{2}$ WO U-Bolt
(2) $\frac{3}{8}$ "-16 Hex Nuts
(1) 2-Hole Plate
- Standard finish: ZN
- Wt./C 50 Lbs. (22.7 kg)

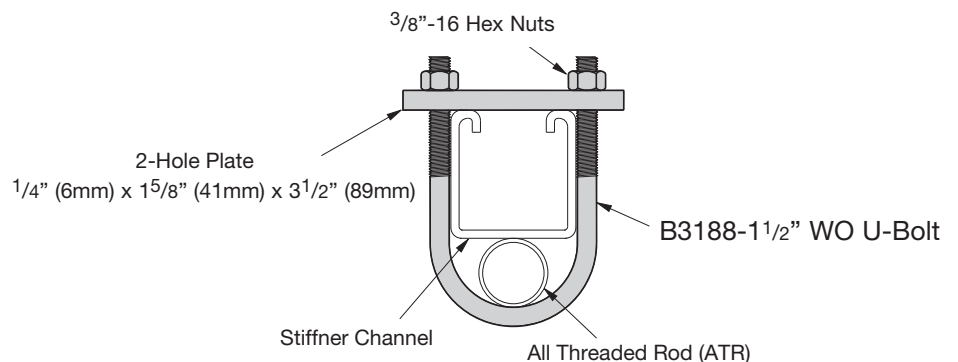

Reference page 44 for general fitting and standard finish specifications.

Hardware

ATR

ALL THREADED ROD

- Available in 36" (91.4 cm), 72" (182.9 cm), 120" (304.8 cm), 144" (365.7 cm) lengths
- Safety Factor of 5 on recommended load
- Standard finish: Zinc-Plated, Stainless Steel Type 304

Part No. & Size	Threads Per Inch	Recommended Load		Wt./C Ft. (3048.0 cm)	
		Lbs.	kN	Lbs.	kg
ATR 1/4"	20	240	(1.07)	12	(5.44)
ATR 5/16"	18	400	(1.78)	19	(8.62)
ATR 3/8"	16	730	(3.24)	29	(13.15)
ATR 1/2"	13	1350	(6.00)	53	(24.04)
ATR 5/8"	11	2160	(9.60)	89	(40.37)
ATR 3/4"	10	3230	(14.37)	123	(55.79)
ATR 7/8"	9	4480	(19.93)	170	(77.11)
ATR 1"	8	5900	(26.24)	225	(102.06)

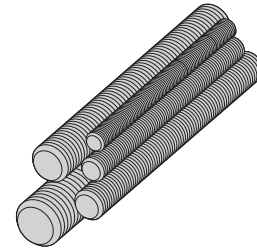

B655 ROD COUPLING B656 REDUCER ROD COUPLING

- Load rating for each coupler meets All Threaded Rod value
- Standard finish: Zinc-Plated, Stainless Steel Type 304

Part No.	Size	Recommended Load		Length	Wt./C	
		Lbs.	kN		Lbs.	kg
B655-1/4	1/4"-20	240	(1.07)	7/8" (22.2)	1.9	(.86)
B655-5/16	5/16"-18	380	(1.69)	7/8" (22.2)	1.8	(.81)
B655-3/8	3/8"-16	730	(3.24)	1 1/8" (28.6)	3.6	(1.63)
B655-1/2	1/2"-13	1350	(6.00)	1 3/4" (44.4)	11.3	(5.12)
B655-5/8	5/8"-11	1810	(8.05)	2 1/8" (54.0)	17.6	(7.98)
B655-3/4	3/4"-10	2710	(12.05)	2 1/4" (57.1)	28.1	(12.74)
B655-7/8	7/8"-9	3770	(16.77)	2 1/2" (63.5)	57.2	(25.94)
B655-1	1"-8	4960	(22.06)	2 3/4" (69.8)	73.7	(33.43)

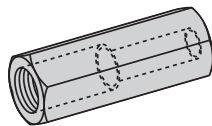
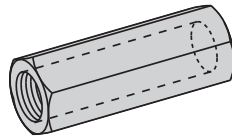

Part No.	Size	Recommended Load		Length	Wt./C	
		Lbs.	kN		Lbs.	kg
B656-3/8 x 1/4	3/8"-16 & 1/4"-20	240	(1.07)	1" (25.4)	3.7	(1.68)
B656-1/2 x 3/8	1/2"-13 & 3/8"-16	730	(3.24)	1 1/4" (31.7)	6.6	(2.99)
B656-5/8 x 1/2	5/8"-11 & 1/2"-13	1350	(6.00)	1 1/4" (31.7)	11.6	(5.26)
B656-3/4 x 5/8	3/4"-10 & 5/8"-11	1810	(8.05)	1 1/2" (38.1)	20.6	(9.34)
B656-7/8 x 3/4	7/8"-9 & 3/4"-10	2710	(12.05)	1 3/4" (44.4)	39.4	(17.87)

BHR SERIES HOT RODS FOR TRAPEZE HANGERS

- 12" length of threaded rod completely assembled with rod coupling, locking hex nuts, square washer, and channel nut.
- Standard finish: Zinc-Plated

Part No.	Rod Size	Recommended Load		Wt./C	
		Lbs.	kN	Lbs.	kg
BHR1225ZN	1/4"-20	240	(1.07)	41	(18.6)
BHR1238ZN	3/8"-16	730	(3.24)	63	(28.6)
BHR1250ZN	1/2"-13	1350	(6.00)	98	(44.4)
BHR1262ZN	5/8"-11	1500	(6.67)	148	(67.1)

Note: Based on use with 12 ga. channel.

(BHR1225, BHR1238, and BHR1250 use combo nut washers instead of square washers and channel nuts)

Reference page 44 for general fitting and standard finish specifications.





KwikWire™ Clamps

Part No.	For Use With Wire Rope Diameters	Box Qty.
BKC100	1/16" & 3/32"	100
BKC200	1/8" & 3/16"	50

See table below for KwikWire™ Clamp Working Loads

KwikWire Clamp Working Loads*

Clamp Part No.	Wire Rope Dia.	Lbs. Safety Factor 5
BKC100	1/16"	0-75
BKC100	3/32"	25-150
BKC200	1/8"	25-250
BKC200	3/16"	50-640

*Working loads shown are for hanging vertically.

For suspending at 15°, 30°, 45° or 60°

angles from vertical, use the following percentage of the working loads from the chart:

15° = 96%
30° = 86%
45° = 70%
60° = 50%



KwikWire™ Wire Rope (Uncoated Galvanized Wire)

Part No.	Rope Dia.		Working Load		Spool
	in.	mm	Lbs.	kg	
BKW063 ⁽¹⁾	1/16"	(1.6)	96	(43.5)	500 ft.
BKW094 ⁽¹⁾	3/32"	(2.3)	184	(83.4)	500 ft.
BKW125 ⁽¹⁾	1/8"	(3.2)	340	(154.2)	500 ft.
BKW188 ⁽²⁾	3/16"	(4.8)	840	(381.0)	250 ft.

(1) Wire Rope Construction Type 7 x 7
(2) Wire Rope Construction Type 7 x 19

Instructions for installing the wire rope in the clamp - No tools are required.



1 Pass the wire rope through the KwikWire Clamp



2 Loop wire rope through/around support



3 Pass wire rope back through KwikWire Clamp



4 Push wire rope through clamp leaving 2" to 3" tail, then apply tension on wire rope

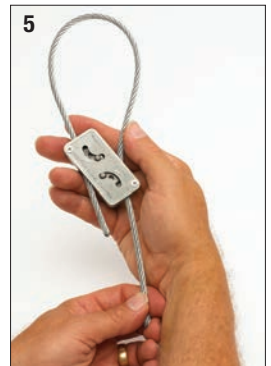

5 To adjust, remove tension and pull wire rope slightly to disengage teeth, slide adjustment pin in direction shown by arrow to release wire rope.



KwikPak™ Wire Rope & Clamps KwikPak

Part No.	For Use With Wire Rope Diameters	Box Qty.
BKP10063	BKC100 (100 pcs.) 1/16"Ø Wire Rope (500 ft.)	1
BKP10094	BKC100 (100 pcs.) 3/32"Ø Wire Rope (500 ft.)	1
BKP20125	BKC200 (50 pcs.) 1/8"Ø Wire Rope (500 ft.)	1
BKP20188	BKC200 (50 pcs.) 3/16"Ø Wire Rope (250 ft.)	1

KwikPak makes handling KwikWire a breeze!

- KwikPaks include KwikWire clamps and a spool of wire rope.
- KwikPaks are shipped in a specially designed dispenser box to ease field cutting of wire.

KwikWire System Recommendations:

- Do not exceed the safe working load of the products
- KwikWire Clamp load ratings are guaranteed only when used in combination with our supplied wire rope
- Do not use for overhead lifting or hoisting
- Do not use if cable or components are visibly distorted or worn. Remove damaged cable end prior to inserting in KwikWire Clamp
- Do not paint cable near working area of KwikWire Clamp
- Do not apply lubricant
- Keep product clean and free of dirt
- Do not use clamp on coated wire rope
- Do not use in chlorinated or caustic atmospheres
- For use in dry locations
- BKCC tool is recommended for cutting wire rope to prevent fraying



KwikWire™ Cable Cutter

Part No.	Box Qty.
BKCC	1

- Wire rope cutter for cutting all wire rope sizes

** Danger: Never use cutters on energized circuits, wire, or cable.



- KwikWire hanger combines the versatility of a bolt with an adjustable wire rope solution.
- Can be quickly installed in existing anchors or metal brackets with a nut.
- ARS, ARC, and ARW anchors are ideal for use with KwikWire Hangers.
- Ideal for supporting light fixtures, wire basket cable tray, HVAC ducts, and sign/banner supports.
- Allows for tool-less adjustment of wire rope.

KwikWire™ Hanger

Part No.	Thread Size	Wire Rope Dia.		Loading* SF5	
		in.	mm	Lbs.	kg
BKF100-4	1/4"-20	1/16"	(1.6)	45	(20.4)
		3/32"	(2.3)	90	(40.8)
BKF100-6	3/8"-16	1/16"	(1.6)	45	(20.4)
		3/32"	(2.3)	90	(40.8)

KwikWire Hanger installation



1
Screw KwikWire Hanger into installed hanger support (ARS anchor pictured)



2
Push cable wire up through the bottom of KwikWire Hanger



3
Continue pushing through until 1/4" minimum is extending out the side of the KwikWire Hanger

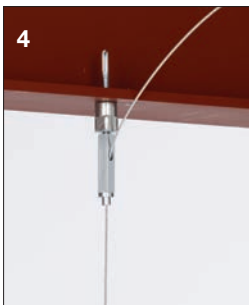

4
To adjust up - pull or push more cable wire through KwikWire Hanger



5
To adjust down - push up on bottom of KwikWire Hanger and allow cable wire to feed down

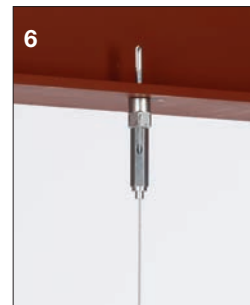

6
When hanging the cable wire is complete, cut off any excess cable wire if desired

KwikWire™ Hardware

KwikWire Accessory Features

- Reduces on the job installation time
- Can be installed quickly without drilling into existing structure
- Increases versatility in the field
- KwikWire accessory system reduces inventory and shipping costs
- No more sawing, filing, or fixing nuts
- Designed for use with cable tray, lighting, and HVAC
- Eliminates the need for all threaded rod
- Cost effective solution for jack chain
- “Y” style accessories require 50% less drilling



KwikWire Accessory Numbering System

Product Line	Assembly Configuration	Leg Termination	Leg Length	Wire Rope Diameter	Straight Length	Assembly or Kit
BK = KwikWire	Blank = Single Leg Y = 2 Legs 3 = 3 Legs	A = Angle Bracket w/Pin H = Hook L = Loop T = Toggle W = Fuse Cut B25 = Bolt w/ 1/4"-20 Thread B38 = Bolt w/ 3/8"-16 Thread BM6 = Bolt w/ M6 Thread BM8 = Bolt w/ M8 Thread BM10 = Bolt w/ M10 Thread	Blank = See Straight Length 18 = 18" Leg 30 = 30" Leg	063 = 1/16" 094 = 3/32"	Blank = Loop w/ Plastic Tube 18 = 18" 30 = 30" 40 = 40" 80 = 80" 120 = 120" 180 = 180" 240 = 240" 360 = 360"	Blank = Assembly Only K = Kit (Assembly & BKC100 Clamp)

Examples

BKYT18-094-120K



B-Line KwikWire Accessory

2 legs - toggle leg termination - 18" legs - 3/32" diameter wire - 120" straight length - kit with clamp

BKL-063-120K



B-Line KwikWire Accessory

single leg - looped leg termination - 1/16" diameter wire - 120" straight length - kit with clamp

Custom assemblies are available as shown by the red dot ● on pages 63 - 70.
Lead time on custom assemblies is 2 to 3 weeks depending on quantities.

KwikWire™ Loop Termination

Part No.	Wire Rope Dia.		Length	
	in.	mm	in.	mm
● BKL-063-40	1/16"	(1.6)	40"	(1016)
● BKL-063-80	1/16"	(1.6)	80"	(2032)
● BKL-063-120	1/16"	(1.6)	120"	(3048)
● BKL-063-180	1/16"	(1.6)	180"	(4572)
● BKL-063-240	1/16"	(1.6)	240"	(6096)
● BKL-063-360	1/16"	(1.6)	360"	(9144)
● BKL-094-40	3/32"	(2.3)	40"	(1016)
● BKL-094-80	3/32"	(2.3)	80"	(2032)
● BKL-094-120	3/32"	(2.3)	120"	(3048)
● BKL-094-180	3/32"	(2.3)	180"	(4572)
● BKL-094-240	3/32"	(2.3)	240"	(6096)
● BKL-094-360	3/32"	(2.3)	360"	(9144)



Box Quantity - 20
5 bags containing 4 pieces per bag

KwikWire™ Loop Termination Kits

Part No.	Wire Rope Dia.		Length	
	in.	mm	in.	mm
● BKL-063-40K	1/16"	(1.6)	40"	(1016)
● BKL-063-80K	1/16"	(1.6)	80"	(2032)
● BKL-063-120K	1/16"	(1.6)	120"	(3048)
● BKL-063-180K	1/16"	(1.6)	180"	(4572)
● BKL-063-240K	1/16"	(1.6)	240"	(6096)
● BKL-063-360K	1/16"	(1.6)	360"	(9144)
● BKL-094-40K	3/32"	(2.3)	40"	(1016)
● BKL-094-80K	3/32"	(2.3)	80"	(2032)
● BKL-094-120K	3/32"	(2.3)	120"	(3048)
● BKL-094-180K	3/32"	(2.3)	180"	(4572)
● BKL-094-240K	3/32"	(2.3)	240"	(6096)
● BKL-094-360K	3/32"	(2.3)	360"	(9144)

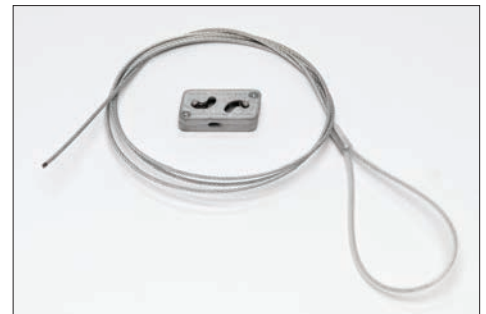

Box Quantity - 20
5 bags containing 4 pieces per bag

Channel Nuts & Hardware

- Available as a wire rope with loop termination only or as a ready-to-use kit with a BKC100 clamp.
- Available in lengths of 40", 80", 120", 180", 240", and 360".

● = Stock item, lead time 2 - 3 working days

● = Non-stock item, lead time 10 - 15 working days

KwikWire™ Single Style Hook Termination



Box Quantity - 20
5 bags containing 4 pieces per bag



Part No.	Wire Rope Dia.		Length	
	in.	mm	in.	mm
● BKH-094-40	3/32"	(2.3)	40"	(1016)
● BKH-094-80	3/32"	(2.3)	80"	(2032)
● BKH-094-120	3/32"	(2.3)	120"	(3048)
● BKH-094-180	3/32"	(2.3)	180"	(4572)
● BKH-094-240	3/32"	(2.3)	240"	(6096)
● BKH-094-360	3/32"	(2.3)	360"	(9144)

KwikWire™ Single Style Hook Termination Kits



Box Quantity - 20
5 bags containing 4 pieces per bag



Part No.	Wire Rope Dia.		Length	
	in.	mm	in.	mm
● BKH-094-40K	3/32"	(2.3)	40"	(1016)
● BKH-094-80K	3/32"	(2.3)	80"	(2032)
● BKH-094-120K	3/32"	(2.3)	120"	(3048)
● BKH-094-180K	3/32"	(2.3)	180"	(4572)
● BKH-094-240K	3/32"	(2.3)	240"	(6096)
● BKH-094-360K	3/32"	(2.3)	360"	(9144)

Channel Nuts & Hardware

KwikWire™ 'Y' Style Hook Termination With Loop

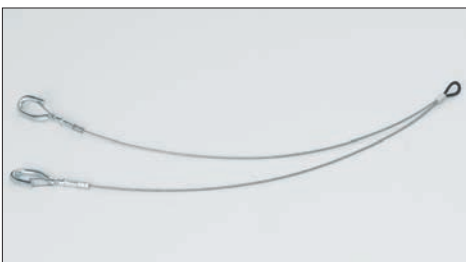

Box Quantity - 10
5 bags containing 2 pieces per bag



Part No.	Wire Rope Dia.		Length	
	in.	mm	in.	mm
● BKYH18-094	3/32"	(2.3)	18"	(457)
● BKYH30-094	3/32"	(2.3)	30"	(762)

- Hook designed to accept up to 3/8" diameter wire.
- Available as a wire rope with hook termination only or as a ready-to-use kit with a BKC100 clamp.
- Available in lengths of 40", 80", 120", 180", 240", and 360".
- Available in single, double (Y), and triple (3) leg styles

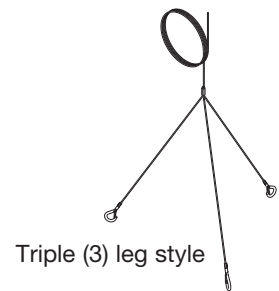

● = Stock item, lead time 2 - 3 working days ● = Non-stock item, lead time 10 - 15 working days

KwikWire™ ‘Y’ Style Hook Termination

Part No.	Leg Length		Wire Rope Dia.		Length	
	in.	mm	in.	mm	in.	mm
● BKYH18-094-40	18"	(457)	3/32"	(2.3)	40"	(1016)
● BKYH18-094-80	18"	(457)	3/32"	(2.3)	80"	(2032)
● BKYH18-094-120	18"	(457)	3/32"	(2.3)	120"	(3048)
● BKYH18-094-180	18"	(457)	3/32"	(2.3)	180"	(4572)
● BKYH18-094-240	18"	(457)	3/32"	(2.3)	240"	(6096)
● BKYH18-094-360	18"	(457)	3/32"	(2.3)	360"	(9144)
● BKYH30-094-40	30"	(762)	3/32"	(2.3)	40"	(1016)
● BKYH30-094-80	30"	(762)	3/32"	(2.3)	80"	(2032)
● BKYH30-094-120	30"	(762)	3/32"	(2.3)	120"	(3048)
● BKYH30-094-180	30"	(762)	3/32"	(2.3)	180"	(4572)
● BKYH30-094-240	30"	(762)	3/32"	(2.3)	240"	(6096)
● BKYH30-094-360	30"	(762)	3/32"	(2.3)	360"	(9144)



Box Quantity - 10
5 bags containing 2 pieces per bag

KwikWire™ ‘Y’ Style Hook Termination Kits

Part No.	Leg Length		Wire Rope Dia.		Length	
	in.	mm	in.	mm	in.	mm
● BKYH18-094-40K	18"	(457)	3/32"	(2.3)	40"	(1016)
● BKYH18-094-80K	18"	(457)	3/32"	(2.3)	80"	(2032)
● BKYH18-094-120K	18"	(457)	3/32"	(2.3)	120"	(3048)
● BKYH18-094-180K	18"	(457)	3/32"	(2.3)	180"	(4572)
● BKYH18-094-240K	18"	(457)	3/32"	(2.3)	240"	(6096)
● BKYH18-094-360K	18"	(457)	3/32"	(2.3)	360"	(9144)
● BKYH30-094-40K	30"	(762)	3/32"	(2.3)	40"	(1016)
● BKYH30-094-80K	30"	(762)	3/32"	(2.3)	80"	(2032)
● BKYH30-094-120K	30"	(762)	3/32"	(2.3)	120"	(3048)
● BKYH30-094-180K	30"	(762)	3/32"	(2.3)	180"	(4572)
● BKYH30-094-240K	30"	(762)	3/32"	(2.3)	240"	(6096)
● BKYH30-094-360K	30"	(762)	3/32"	(2.3)	360"	(9144)



Box Quantity - 10
5 bags containing 2 pieces per bag

Channel Nuts & Hardware

- Hook designed to accept up to 3/8" diameter wire.
- Available as a wire rope with loop termination only or as a ready-to-use kit with a BKC100 clamp.
- Available in lengths of 40", 80", 120", 180", 240", and 360".

● = Stock item, lead time 2 - 3 working days

● = Non-stock item, lead time 10 - 15 working days

KwikWire™ Single Style Toggle Termination



Box Quantity - 20
5 bags containing 4 pieces per bag



Part No.	Wire Rope Dia.		Length	
	in.	mm	in.	mm
● BKT-063-40	1/16"	(1.6)	40"	(1016)
● BKT-063-80	1/16"	(1.6)	80"	(2032)
● BKT-063-120	1/16"	(1.6)	120"	(3048)
● BKT-063-180	1/16"	(1.6)	180"	(4572)
● BKT-063-240	1/16"	(1.6)	240"	(6096)
● BKT-063-360	1/16"	(1.6)	360"	(9144)

KwikWire™ Single Style Toggle Termination Kits

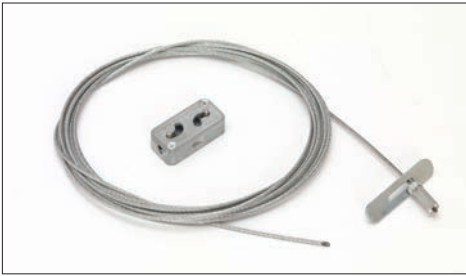

Box Quantity - 20
5 bags containing 4 pieces per bag



Part No.	Wire Rope Dia.		Length	
	in.	mm	in.	mm
● BKT-063-40K	1/16"	(1.6)	40"	(1016)
● BKT-063-80K	1/16"	(1.6)	80"	(2032)
● BKT-063-120K	1/16"	(1.6)	120"	(3048)
● BKT-063-180K	1/16"	(1.6)	180"	(4572)
● BKT-063-240K	1/16"	(1.6)	240"	(6096)
● BKT-063-360K	1/16"	(1.6)	360"	(9144)

KwikWire™ ‘Y’ Style Toggle Termination With Loop



Box Quantity - 10
5 bags containing 2 pieces per bag



Part No.	Wire Rope Dia.		Length	
	in.	mm	in.	mm
● BKYT12-063	1/16"	(1.6)	12"	(305)
● BKYT18-063	1/16"	(1.6)	18"	(457)
● BKYT30-063	1/16"	(1.6)	30"	(762)

- Available as a wire rope with toggle termination only or as a ready-to-use kit with a BKC100 clamp.
- Available in lengths of 40", 80", 120", 180", 240", and 360".
- Available in single, double (Y), and triple (3) leg styles
- All triple (3) leg styles are non-stock, consult B-Line for lead times

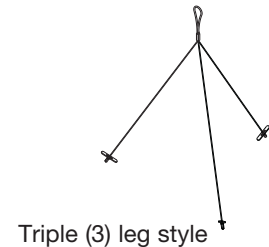

● = Stock item, lead time 2 - 3 working days ● = Non-stock item, lead time 10 - 15 working days

KwikWire™ ‘Y’ Style Toggle Termination

Part No.	Leg Length		Wire Rope Dia.		Length	
	in.	mm	in.	mm	in.	mm
● BKYT12-063-40	12"	(305)	1/16"	(1.6)	40"	(1016)
● BKYT12-063-80	12"	(305)	1/16"	(1.6)	80"	(2032)
● BKYT12-063-120	12"	(305)	1/16"	(1.6)	120"	(3048)
● BKYT12-063-180	12"	(305)	1/16"	(1.6)	180"	(4572)
● BKYT12-063-240	12"	(305)	1/16"	(1.6)	240"	(6096)
● BKYT12-063-360	12"	(305)	1/16"	(1.6)	360"	(9144)
● BKYT18-063-40	18"	(457)	1/16"	(1.6)	40"	(1016)
● BKYT18-063-80	18"	(457)	1/16"	(1.6)	80"	(2032)
● BKYT18-063-120	18"	(457)	1/16"	(1.6)	120"	(3048)
● BKYT18-063-180	18"	(457)	1/16"	(1.6)	180"	(4572)
● BKYT18-063-240	18"	(457)	1/16"	(1.6)	240"	(6096)
● BKYT18-063-360	18"	(457)	1/16"	(1.6)	360"	(9144)
● BKYT30-063-40	30"	(762)	1/16"	(1.6)	40"	(1016)
● BKYT30-063-80	30"	(762)	1/16"	(1.6)	80"	(2032)
● BKYT30-063-120	30"	(762)	1/16"	(1.6)	120"	(3048)
● BKYT30-063-180	30"	(762)	1/16"	(1.6)	180"	(4572)
● BKYT30-063-240	30"	(762)	1/16"	(1.6)	240"	(6096)
● BKYT30-063-360	30"	(762)	1/16"	(1.6)	360"	(9144)



Box Quantity - 10
5 bags containing 2 pieces per bag

KwikWire™ ‘Y’ Style Toggle Termination Kits

Part No.	Leg Length		Wire Rope Dia.		Length	
	in.	mm	in.	mm	in.	mm
● BKYT12-063-40K	12"	(305)	1/16"	(1.6)	40"	(1016)
● BKYT12-063-80K	12"	(305)	1/16"	(1.6)	80"	(2032)
● BKYT12-063-120K	12"	(305)	1/16"	(1.6)	120"	(3048)
● BKYT12-063-180K	12"	(305)	1/16"	(1.6)	180"	(4572)
● BKYT12-063-240K	12"	(305)	1/16"	(1.6)	240"	(6096)
● BKYT12-063-360K	12"	(305)	1/16"	(1.6)	360"	(9144)
● BKYT18-063-40K	18"	(457)	1/16"	(1.6)	40"	(1016)
● BKYT18-063-80K	18"	(457)	1/16"	(1.6)	80"	(2032)
● BKYT18-063-120K	18"	(457)	1/16"	(1.6)	120"	(3048)
● BKYT18-063-180K	18"	(457)	1/16"	(1.6)	180"	(4572)
● BKYT18-063-240K	18"	(457)	1/16"	(1.6)	240"	(6096)
● BKYT18-063-360K	18"	(457)	1/16"	(1.6)	360"	(9144)
● BKYT30-063-40K	30"	(762)	1/16"	(1.6)	40"	(1016)
● BKYT30-063-80K	30"	(762)	1/16"	(1.6)	80"	(2032)
● BKYT30-063-120K	30"	(762)	1/16"	(1.6)	120"	(3048)
● BKYT30-063-180K	30"	(762)	1/16"	(1.6)	180"	(4572)
● BKYT30-063-240K	30"	(762)	1/16"	(1.6)	240"	(6096)
● BKYT30-063-360K	30"	(762)	1/16"	(1.6)	360"	(9144)



Box Quantity - 10
5 bags containing 2 pieces per bag

Channel Nuts & Hardware

- Available as a wire rope with loop termination only or as a ready-to-use kit with a BKC100 clamp.
- Available in lengths of 40", 80", 120", 180", 240", and 360".

● = Stock item, lead time 2 - 3 working days

● = Non-stock item, lead time 10 - 15 working days

KwikWire™ Bolt Termination



Box Quantity - 20
5 bags containing 4 pieces per bag

Part No.	Thread Size	Wire Rope Dia.		Length	
		in.	mm	in.	mm
● BKB25-063-40	1/4"-20	1/16"	(1.6)	40"	(1016)
● BKB25-063-80	1/4"-20	1/16"	(1.6)	80"	(2032)
● BKB25-063-120	1/4"-20	1/16"	(1.6)	120"	(3048)
● BKB25-063-180	1/4"-20	1/16"	(1.6)	180"	(4572)
● BKB25-063-240	1/4"-20	1/16"	(1.6)	240"	(6096)
● BKB25-063-360	1/4"-20	1/16"	(1.6)	360"	(9144)
● BKB38-094-40	3/8"-16	3/32"	(2.3)	40"	(1016)
● BKB38-094-80	3/8"-16	3/32"	(2.3)	80"	(2032)
● BKB38-094-120	3/8"-16	3/32"	(2.3)	120"	(3048)
● BKB38-094-180	3/8"-16	3/32"	(2.3)	180"	(4572)
● BKB38-094-240	3/8"-16	3/32"	(2.3)	240"	(6096)
● BKB38-094-360	3/8"-16	3/32"	(2.3)	360"	(9144)

- Ideal for use with ARS, ARC, ADI, ACPW, or ACPD anchors.
- Available as a wire rope with bolt termination only or as a ready-to-use kit with a BKC100 clamp.
- Available in lengths of 40", 80", 120", 180", 240", and 360".
- Available in single, double (Y), and triple leg (3) styles
- All (Y) and triple (3) styles are non-stock, consult B-Line for lead times

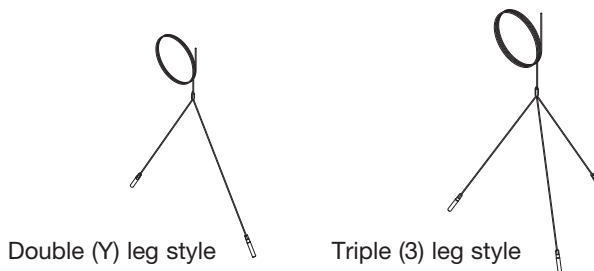

● = Stock item, lead time 2 - 3 working days ● = Non-stock item, lead time 10 - 15 working days

KwikWire™ Bolt Termination Kits

Part No.	Thread Size	Wire Rope Dia.		Length	
		in.	mm	in.	mm
● BKB25-063-40K	1/4"-20	1/16"	(1.6)	40"	(1016)
● BKB25-063-80K	1/4"-20	1/16"	(1.6)	80"	(2032)
● BKB25-063-120K	1/4"-20	1/16"	(1.6)	120"	(3048)
● BKB25-063-180K	1/4"-20	1/16"	(1.6)	180"	(4572)
● BKB25-063-240K	1/4"-20	1/16"	(1.6)	240"	(6096)
● BKB25-063-360K	1/4"-20	1/16"	(1.6)	360"	(9144)
● BKB38-094-40K	3/8"-16	3/32"	(2.3)	40"	(1016)
● BKB38-094-80K	3/8"-16	3/32"	(2.3)	80"	(2032)
● BKB38-094-120K	3/8"-16	3/32"	(2.3)	120"	(3048)
● BKB38-094-180K	3/8"-16	3/32"	(2.3)	180"	(4572)
● BKB38-094-240K	3/8"-16	3/32"	(2.3)	240"	(6096)
● BKB38-094-360K	3/8"-16	3/32"	(2.3)	360"	(9144)



Box Quantity - 20
5 bags containing 4 pieces per bag

- Ideal for use with ARS, ARC, ADI, ACPW, or ACPD anchors.
- Available as a wire rope with bolt termination only or as a ready-to-use kit with a BKC100 clamp.
- Available in lengths of 40", 80", 120", 180", 240", and 360".
- Available in single, double (Y), and triple (3) styles
- All double (Y) and triple (3) styles are non-stock, consult B-Line for lead times

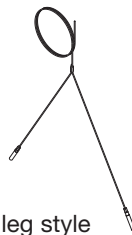

Double (Y) leg style



Triple (3) leg style

● = Stock item, lead time 2 - 3 working days

● = Non-stock item, lead time 10 - 15 working days

KwikWire™ Angle Bracket Termination



Box Quantity - 20
5 bags containing 4 pieces per bag



Part No.	Wire Rope Dia.		Length	
	in.	mm	in.	mm
● BKA-063-40	1/16"	(1.6)	40"	(1016)
● BKA-063-80	1/16"	(1.6)	80"	(2032)
● BKA-063-120	1/16"	(1.6)	120"	(3048)
● BKA-063-180	1/16"	(1.6)	180"	(4572)
● BKA-063-240	1/16"	(1.6)	240"	(6096)
● BKA-063-360	1/16"	(1.6)	360"	(9144)

KwikWire™ Angle Bracket Termination Kits



Box Quantity - 20
5 bags containing 4 pieces per bag



Part No.	Wire Rope Dia.		Length	
	in.	mm	in.	mm
● BKA-063-40K	1/16"	(1.6)	40"	(1016)
● BKA-063-80K	1/16"	(1.6)	80"	(2032)
● BKA-063-120K	1/16"	(1.6)	120"	(3048)
● BKA-063-180K	1/16"	(1.6)	180"	(4572)
● BKA-063-240K	1/16"	(1.6)	240"	(6096)
● BKA-063-360K	1/16"	(1.6)	360"	(9144)

- Available as a wire rope with angle bracket termination only or as a ready-to-use kit with a BKC100 clamp.
- Available in lengths of 40", 80", 120", 180", 240", and 360".

● = Stock item, lead time 2 - 3 working days

● = Non-stock item, lead time 10 - 15 working days

Fittings

This section offers a full selection of fittings and accessories to complete our strut system. Fittings are made from hot rolled, pickled and oiled plate or strip steel in accordance with ASTM A1018 33,000 PSI min. yield, unless noted.

Dimensions

The following dimensions apply to all fittings except as noted:

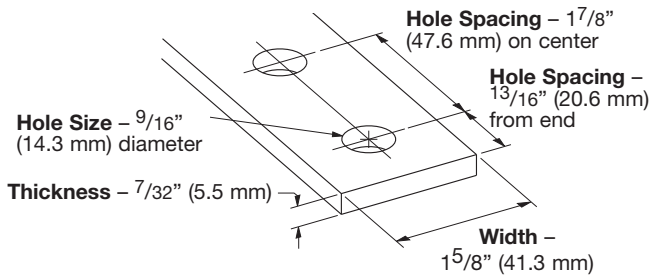

Materials & Finishes (Unless otherwise noted)

Finish Code	Finish	Specification
PLN	Plain	ASTM A1018 33,000 PSI min. yield
ZN	Electro-Plated Zinc	ASTM B633 SC3 Type III or ASTM A653
GRN	DURA-GREEN™	
HDG	Hot-Dipped Galvanized	ASTM A123
SS4	Stainless Steel Type 304	ASTM A240
SS6	Stainless Steel Type 316	ASTM A240
AL	Aluminum	ASTM B209

Note: A minimum order may apply on special material and finishes.

Load Data

The load data published includes safety factor of 2.5 when used with 12 ga. (2.6) channel (safety factor = ratio of ultimate load to the design load).

Use $\frac{1}{2}$ "-13 x $\frac{7}{8}$ " hex head cap screws and $\frac{1}{2}$ "-13 (N225 or TN225) channel nuts for the rated results.

Recommended Bolt Torque

Bolt Size	$\frac{1}{4}$ "-20	$\frac{5}{16}$ "-18	$\frac{3}{8}$ "-16	$\frac{1}{2}$ "-13
Foot/Lbs.	6	11	19	50
Nm	8	15	26	68

See chart on page 112 for setscrew torque.

Hardware

Nuts and bolts are not included with the fittings and must be ordered separately, unless noted.

Pre-Assembled Fittings

Some fittings are available with hex head cap screws and channel nuts pre-assembled. These fittings and finishes will be flagged using the following symbol.



Metric

Metric dimensions are shown in parentheses. Unless noted, all metric dimensions are in millimeters.



Flat Plate Fittings

B200-B202-2

- Standard finishes: ZN, GRN, HDG, SS4, SS6, AL

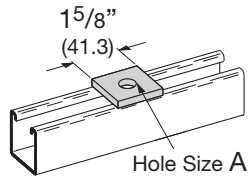

SQUARE WASHER

Part No.	A	(A)	Bolt Size	Wt./C	
				Lbs.	kg
B200	3/8"	(9.5)	5/16" (7.9)	18	(8.1)
B201	7/16"	(11.1)	3/8" (9.5)	18	(8.1)
B202	9/16"	(14.2)	1/2" (12.7)	17	(7.7)
B202-1	11/16"	(17.4)	5/8" (15.9)	16	(7.2)
B202-2	13/16"	(20.6)	3/4" (19.0)	15	(6.8)

B200D-B202-2D

- Standard finishes: ZN, GRN, HDG, SS4, SS6, AL

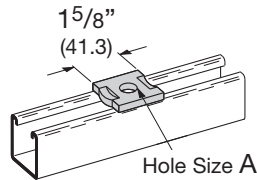

NO TWIST SQUARE WASHER

Part No.	A	(A)	Bolt Size	Wt./C	
				Lbs.	kg
B200D	3/8"	(9.5)	5/16" (7.9)	18	(8.1)
B201D	7/16"	(11.1)	3/8" (9.5)	18	(8.1)
B202D	9/16"	(14.2)	1/2" (12.7)	17	(7.7)
B202-1D	11/16"	(17.4)	5/8" (15.9)	16	(7.2)
B202-2D	13/16"	(20.6)	3/4" (19.0)	15	(6.8)

B129 TWO HOLE SPLICE PLATE

- Standard finishes: ZN, GRN
- Wt./C 37 Lbs. (16.8 kg)

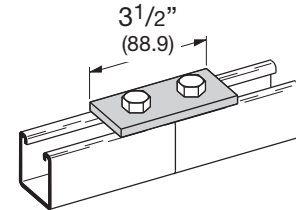

B340 TWO HOLE SPLICE PLATE

- Standard finishes: ZN, GRN
- Wt./C 34 Lbs. (15.4 kg)

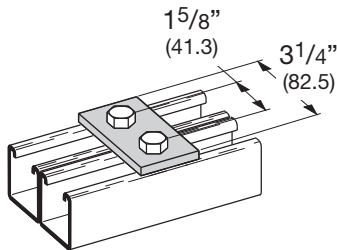

B528 TWO HOLE SPLICE PLATE

- Standard finishes: ZN, GRN
- Wt./C 50 Lbs. (22.7 kg)

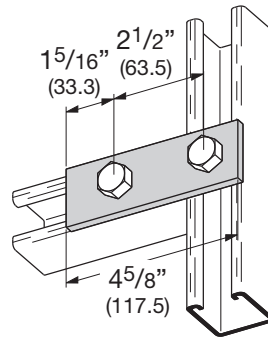

B141 THREE HOLE SPLICE PLATE

- Standard finishes: ZN, GRN
- Wt./C 55 Lbs. (24.9 kg)

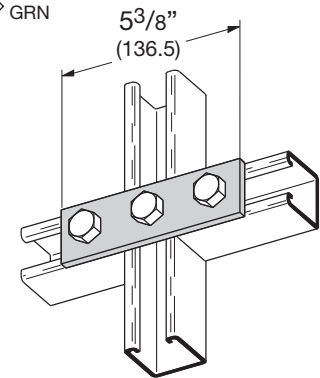

B557 THREE HOLE SPLICE PLATE

- Standard finishes: ZN, GRN
- Wt./C 50 Lbs. (22.7 kg)

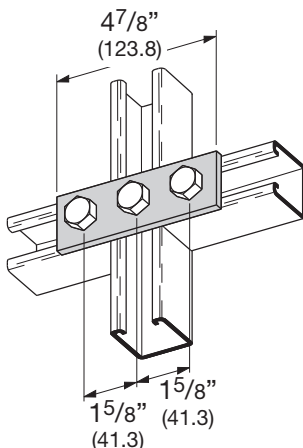

B341 FOUR HOLE SPLICE PLATE

- Standard finishes: ZN, GRN, HDG
- Wt./C 76 Lbs. (34.5 kg)

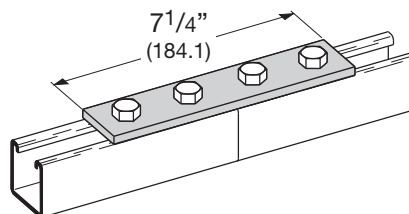

B342 FIVE HOLE SPLICE PLATE

- Standard finishes: ZN, GRN
- Wt./C 96 Lbs. (43.5 kg)

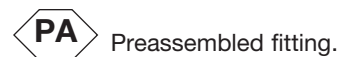
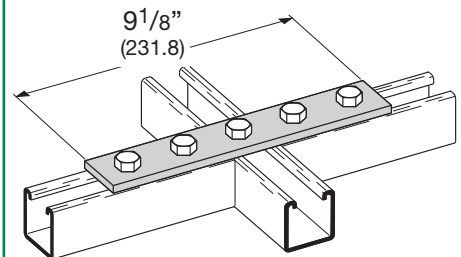

Reference page 72 for general fitting and standard finish specifications.

Flat Plate Fittings

B138 TWO HOLE SWIVEL PLATE

- Standard finishes: ZN, GRN
- Wt./C 48 Lbs. (21.8 kg)

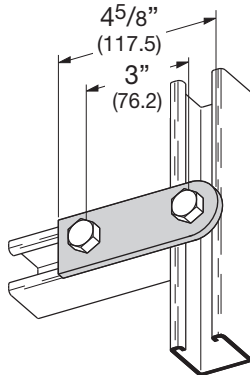

B139 THREE HOLE SWIVEL PLATE

- Standard finishes: ZN, GRN
- Wt./C 69 Lbs. (31.3 kg)

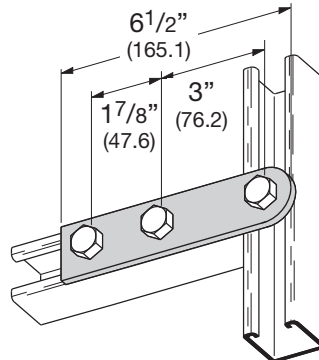

B504 FOUR HOLE SPLICE PLATE

- Standard finishes: ZN, GRN
- Wt./C 73 Lbs. (33.1 kg)

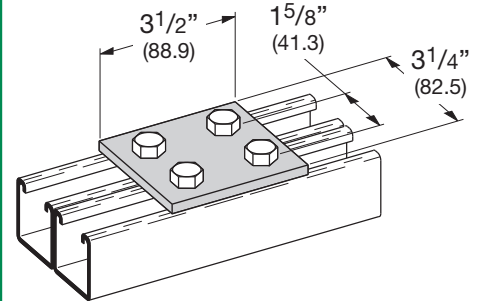

B140 THREE HOLE CORNER PLATE

- Standard finishes: ZN, GRN, HDG, SS4
- Wt./C 56 Lbs. (25.4 kg)

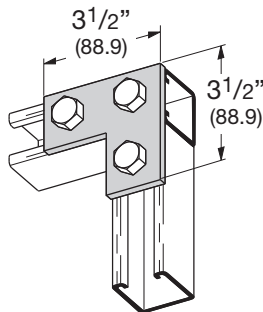

B143 FOUR HOLE CORNER PLATE

- Standard finishes: ZN, GRN, HDG, SS4
- Wt./C 75 Lbs. (34.0 kg)

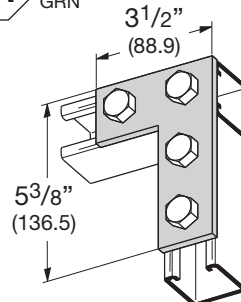

B133 FOUR HOLE TEE PLATE

- Standard finishes: ZN, GRN, HDG, SS4, AL
- Wt./C 75 Lbs. (34.0 kg)

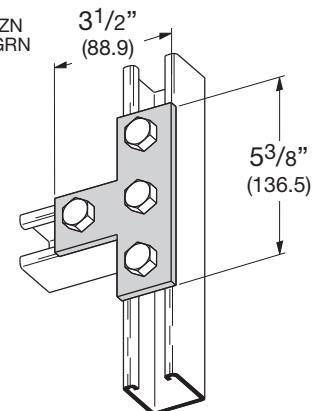

B132 FIVE HOLE CROSS PLATE

- Standard finishes: ZN, GRN, HDG
- Wt./C 100 Lbs. (45.3 kg)

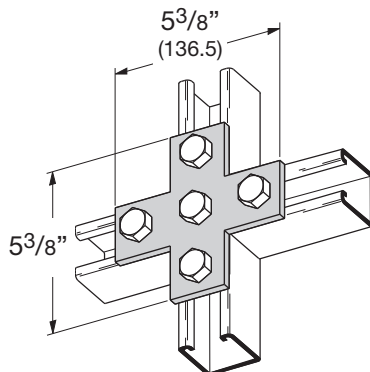

B135 THREE HOLE CORNER GUSSET PLATE

- Standard finishes: ZN, GRN
- Wt./C 70 Lbs. (31.7 kg)

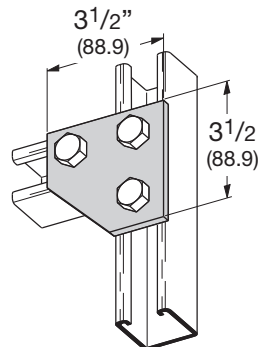

B142 FOUR HOLE CORNER GUSSET PLATE

- Standard finishes: ZN, GRN, HDG
- Wt./C 102 Lbs. (46.2 kg)

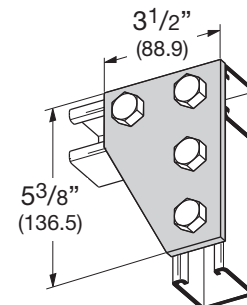

PA Preassembled fitting.

Reference page 72 for general fitting and standard finish specifications.

Flat Plate Fittings

B137 FOUR HOLE CORNER GUSSET PLATE

- Standard finishes: ZN, GRN
- Wt./C 273 Lbs. (123.8 kg)

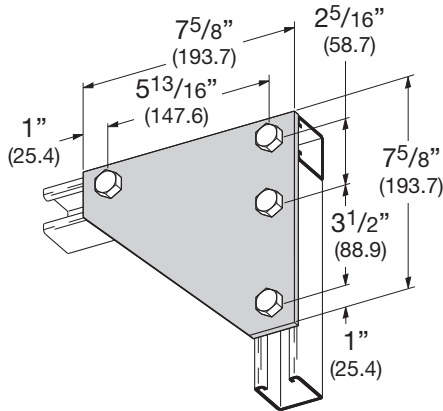

B556 FIVE HOLE CORNER GUSSET PLATE

- Standard finishes: ZN, GRN
- Wt./C 145 Lbs. (65.8 kg)

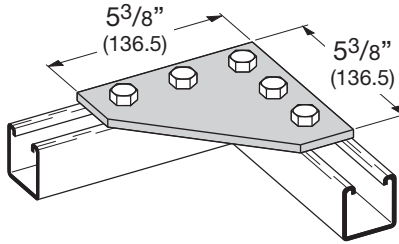

B337 THREE HOLE TEE GUSSET PLATE

- Standard finishes: ZN, GRN
- Wt./C 70 Lbs. (31.7 kg)

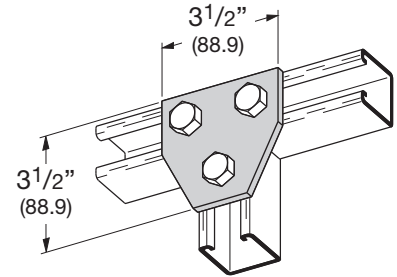

B432 FOUR HOLE TEE GUSSET PLATE

- Standard finishes: ZN, GRN
- Wt./C 100 Lbs. (45.3 kg)

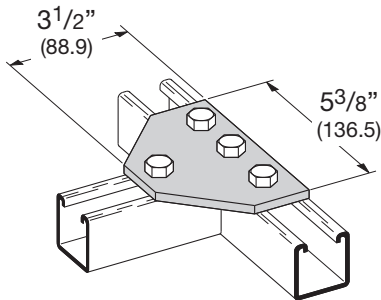

B136 FOUR HOLE TEE GUSSET PLATE

- Standard finishes: ZN, GRN, HDG
- Wt./C 100 Lbs. (45.3 kg)

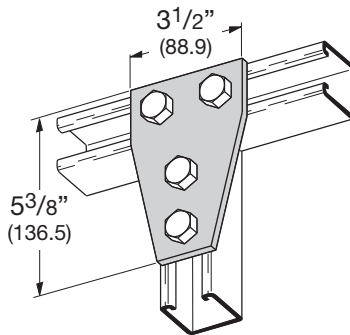

B532 FIVE HOLE TEE GUSSET PLATE

- Standard finishes: ZN, GRN
- Wt./C 143 Lbs. (64.8 kg)

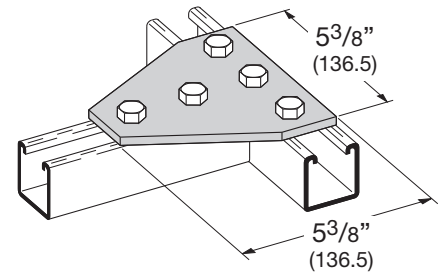

B339 SIX HOLE TEE GUSSET PLATE

- Standard finishes: ZN, GRN
- Wt./C 149 Lbs. (67.6 kg)

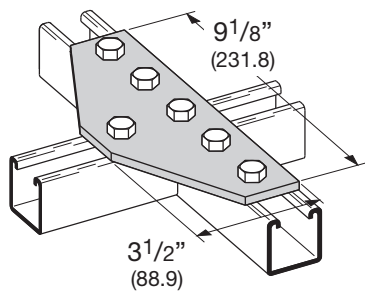

B568 SIX HOLE CROSS GUSSET PLATE

- Standard finishes: ZN, GRN
- Wt./C 166 Lbs. (75.3 kg)

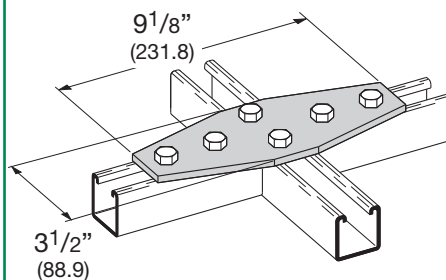

B334 SEVEN HOLE CROSS GUSSET PLATE

- Standard finishes: ZN, GRN
- Wt./C 232 Lbs. (105.2 kg)

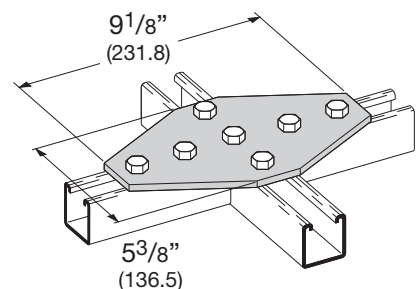

Reference page 75 for general fitting and standard finish specifications.

90° Angle Fittings

B420-378 ONE HOLE CORNER ANGLE

- Standard finishes: ZN, GRN
- Wt./C 60 Lbs. (27.2 kg)

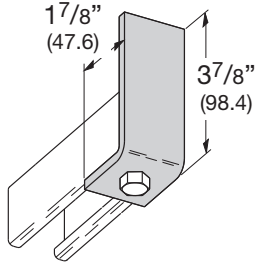

B420-578 ONE HOLE CORNER ANGLE

- Standard finishes: ZN, GRN
- Wt./C 85 Lbs. (38.5 kg)

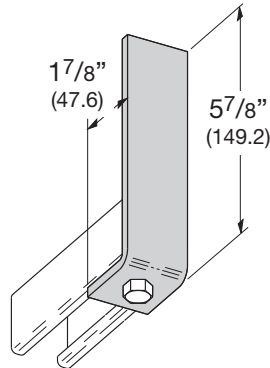

B420-778 ONE HOLE CORNER ANGLE

- Standard finishes: ZN, GRN
- Wt./C 107 Lbs. (48.5 kg)

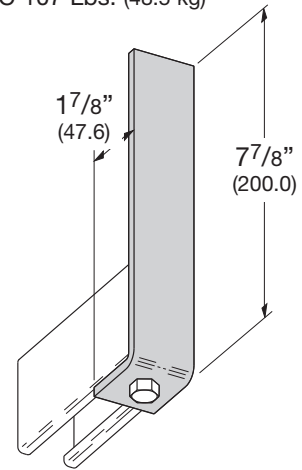

B420-978 ONE HOLE CORNER ANGLE

- Standard finishes: ZN, GRN
- Wt./C 129 Lbs. (58.5 kg)

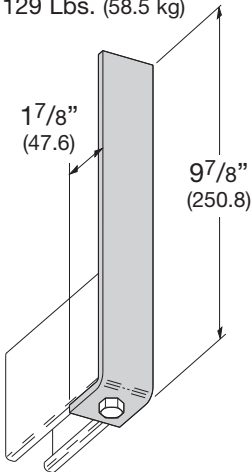

B101 TWO HOLE CORNER ANGLE

- Standard finishes: ZN, GRN, HDG, SS4, AL
- Wt./C 37 Lbs. (16.8 kg)

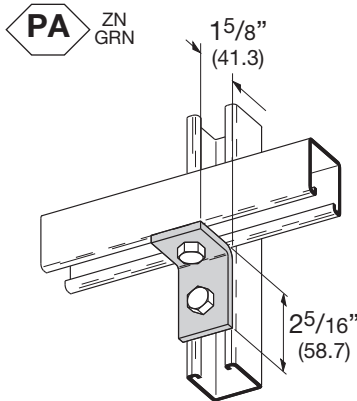

B230 TWO HOLE CORNER ANGLE

- Standard finishes: ZN, GRN, HDG, SS4, AL
- Wt./C 37 Lbs. (16.8 kg)

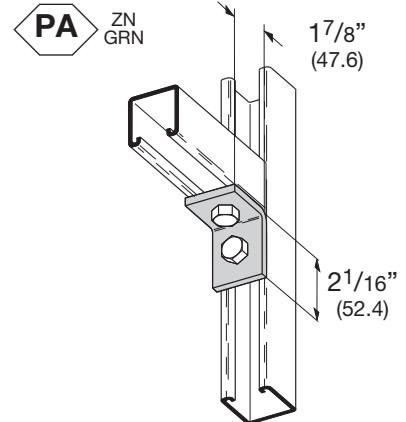

B231 TWO HOLE "NO-TWIST" CORNER ANGLE

- Standard finishes: ZN, GRN, HDG
- Wt./C 41 Lbs. (18.6 kg)

PA ZN GRN

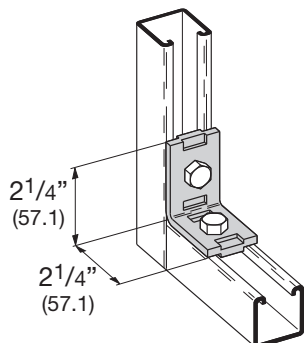

B359 TWO HOLE CORNER ANGLE

- Standard finishes: ZN, GRN
- Wt./C 48 Lbs. (21.8 kg)

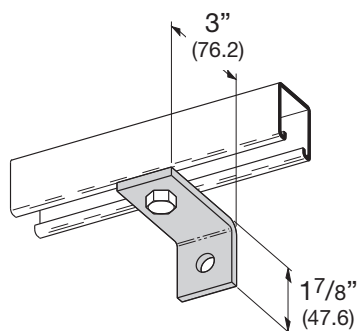

B360 TWO HOLE CORNER ANGLE

- Standard finishes: ZN, GRN
- Wt./C 53 Lbs. (24.0 kg)

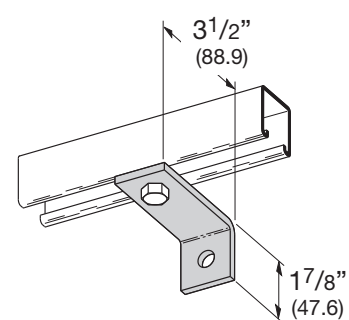

Strut Fittings

PA Preassembled fitting.

Reference page 72 for general fitting and standard finish specifications.

90° Angle Fittings

B361 TWO HOLE CORNER ANGLE

- Standard finishes: ZN, GRN
- Wt./C 60 Lbs. (27.2 kg)

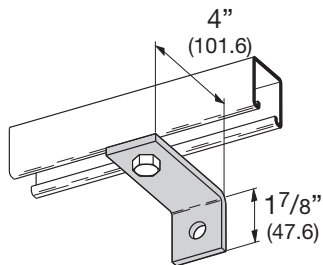

B102 THREE HOLE CORNER ANGLE

- Standard finishes: ZN, GRN, HDG, SS4
- Wt./C 56 Lbs. (25.4 kg)

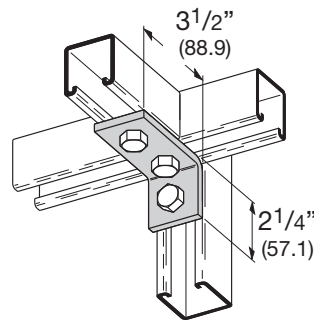

B103 THREE HOLE CORNER ANGLE

- Standard finishes: ZN, GRN, HDG, SS4
- Wt./C 56 Lbs. (25.4 kg)

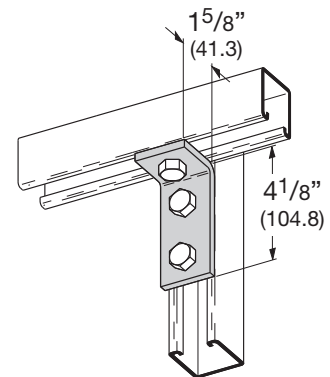

B232 THREE HOLE CORNER ANGLE

- Standard finishes: ZN, GRN, HDG, SS4
- Wt./C 56 Lbs. (25.4 kg)

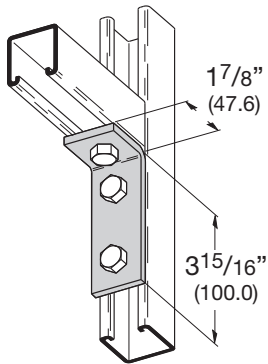

B374 THREE HOLE CORNER ANGLE

- Standard finishes: ZN, GRN, HDG
- Wt./C 56 Lbs. (25.4 kg)

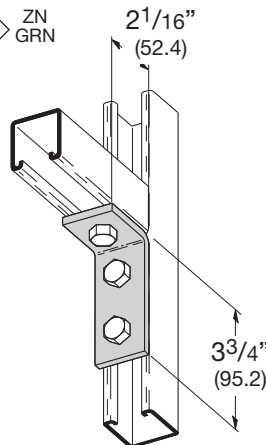

B529 THREE HOLE CORNER ANGLE

- Standard finishes: ZN, GRN
- Wt./C 78 Lbs. (35.4 kg)

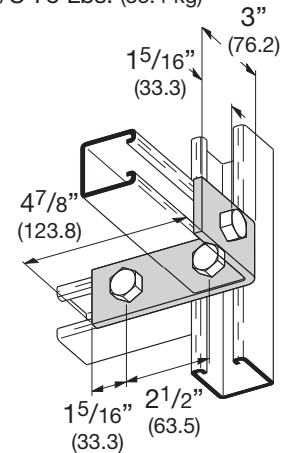

B104 FOUR HOLE CORNER ANGLE

- Standard finishes: ZN, GRN, HDG, SS4, SS6, AL
- Wt./C 78 Lbs. (35.4 kg)

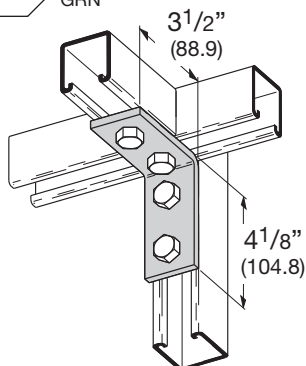

B115 FOUR HOLE CORNER ANGLE

- Standard finishes: ZN, GRN, HDG, SS4, AL
- Wt./C 76 Lbs. (34.5 kg)

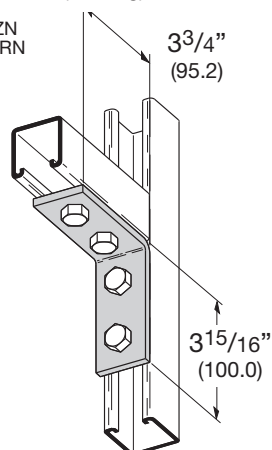

B558 FOUR HOLE CORNER ANGLE

- Standard finishes: ZN, GRN
- Wt./C 73 Lbs. (33.1 kg)

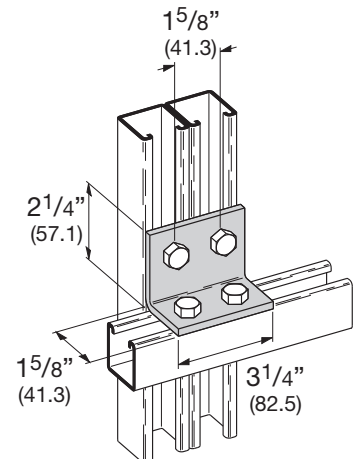

Preassembled fitting.

Reference page 72 for general fitting and standard finish specifications.

90° Angle Fittings

B235R THREE HOLE (RIGHT HAND) OFFSET BENT ANGLE

- 15/8" (41.3) from center to center of the holes that are shown with bolt heads
- Standard finishes: ZN, GRN
- Wt./C 53 Lbs. (24.0 kg)

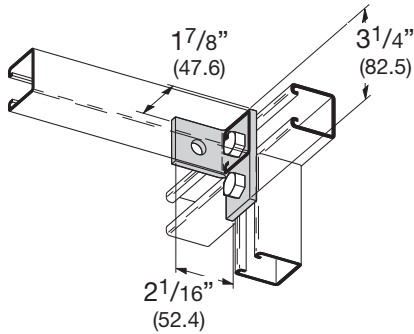

B235L THREE HOLE (LEFT HAND) OFFSET BENT ANGLE

- 15/8" (41.3) from center to center of the holes that are shown with bolt heads
- Standard finishes: ZN, GRN
- Wt./C 53 Lbs. (24.0 kg)

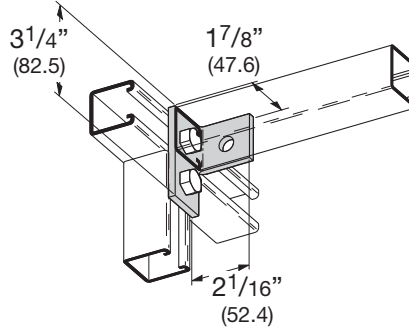

B236R THREE HOLE (RIGHT HAND) OFFSET BENT ANGLE

- Standard finishes: ZN, GRN
- Wt./C 65 Lbs. (29.5 kg)

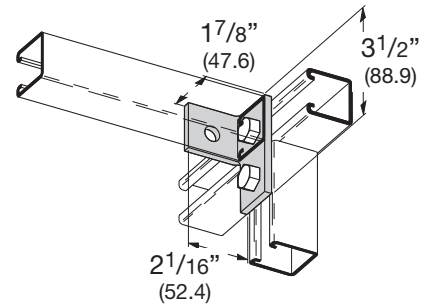

B236L THREE HOLE (LEFT HAND) OFFSET BENT ANGLE

- Standard finishes: ZN, GRN
- Wt./C 65 Lbs. (29.5 kg)

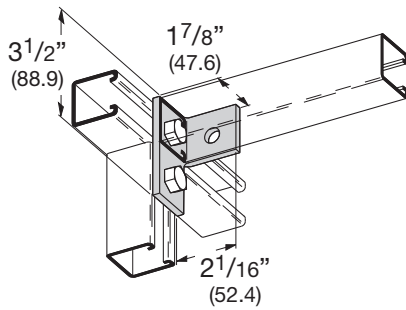

B237 THREE HOLE OFFSET BENT TEE

- Standard finishes: ZN, GRN
- Wt./C 71 Lbs. (32.2 kg)

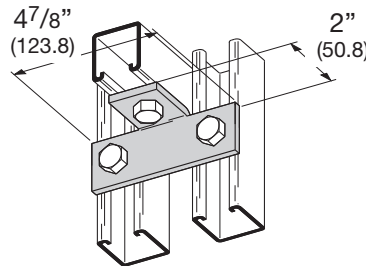

B357 FOUR HOLE OFFSET BENT TEE

- Standard finishes: ZN, GRN
- Wt./C 77 Lbs. (34.9 kg)

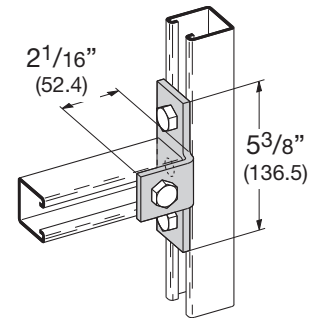

B238R FOUR HOLE (RIGHT HAND) OFFSET BENT TEE

- Standard finishes: ZN, GRN
- Wt./C 76 Lbs. (34.5 kg)

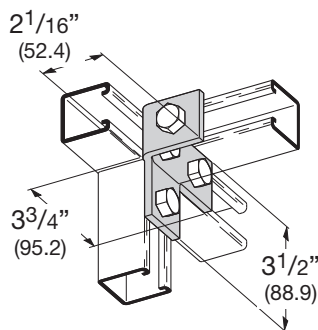

B238L FOUR HOLE (LEFT HAND) OFFSET BENT TEE

- Standard finishes: ZN, GRN
- Wt./C 76 Lbs. (34.5 kg)

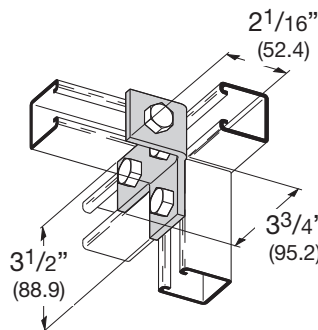

B239 FIVE HOLE OFFSET BENT TEE

- Standard finishes: ZN, GRN
- Wt./C 96 Lbs. (43.5 kg)

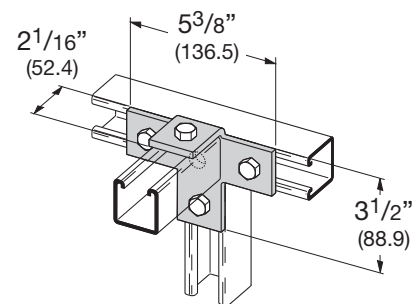

Reference page 72 for general fitting and standard finish specifications.

90° Angle Fittings

B844 UNIVERSAL SHELF BRACKET

- Standard finishes: ZN, GRN, HDG, SS4
- Wt./C 132 Lbs. (59.9 kg)

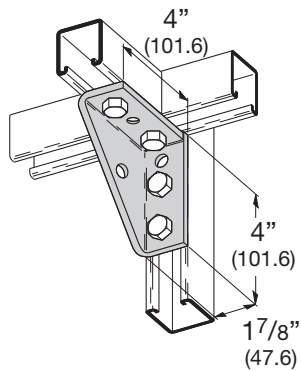

B844W UNIVERSAL SHELF BRACKET- WELDED

- Standard finishes: ZN, GRN
- Wt./C 134 Lbs. (60.8 kg)

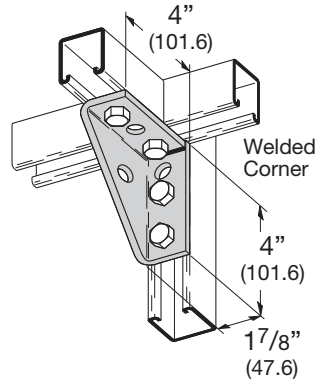

B888W UNIVERSAL SHELF BRACKET- WELDED

- Standard finishes: ZN, GRN
- Wt./C 197 Lbs. (89.4 kg)

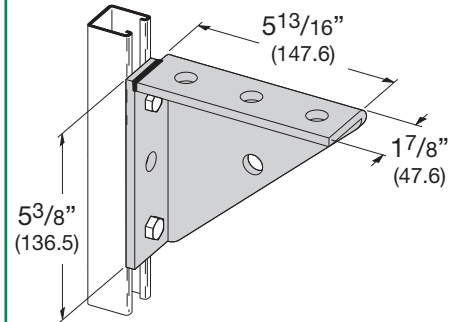

B234R FOUR HOLE (RIGHT HAND) CORNER GUSSET

- Standard finishes: ZN, GRN, HDG
- Wt./C 100 Lbs. (45.3 kg)

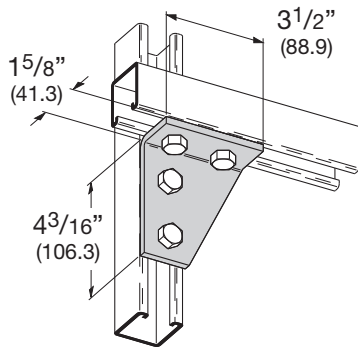

B234L FOUR HOLE (LEFT HAND) CORNER GUSSET

- Standard finishes: ZN, GRN, HDG
- Wt./C 100 Lbs. (45.3 kg)

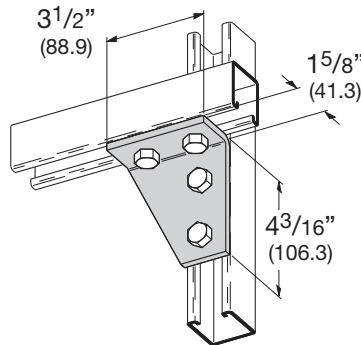

B134R FOUR HOLE (RIGHT HAND) CORNER GUSSET

- Standard finishes: ZN, GRN
- Wt./C 100 Lbs. (45.3 kg)

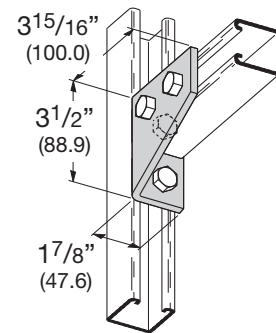

B134L FOUR HOLE (LEFT HAND) CORNER GUSSET

- Standard finishes: ZN, GRN
- Wt./C 100 Lbs. (45.3 kg)

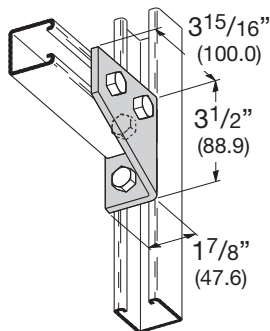

B125 THREE HOLE GUSSETED SHELF ANGLE

- Standard finishes: ZN, GRN
- Wt./C 67 Lbs. (30.4 kg)

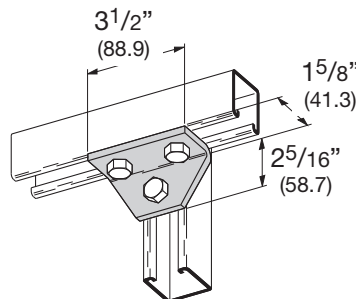

B118 FOUR HOLE GUSSETED SHELF ANGLE

- Standard finishes: ZN, GRN, HDG
- Wt./C 102 Lbs. (46.2 kg)

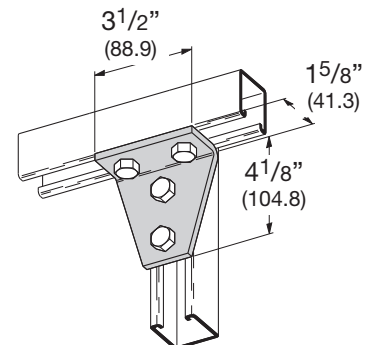

Reference page 72 for general fitting and standard finish specifications.

90° Angle Fittings

B485 FOUR HOLE GUSSETED SHELF ANGLE

- Standard finishes: ZN, GRN
- Wt./C 148 Lbs. (67.1 kg)

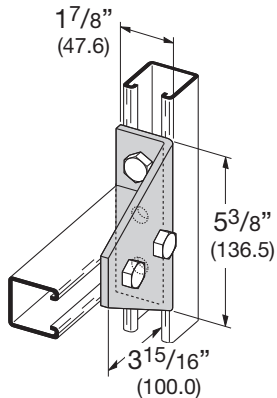

B533 FIVE HOLE GUSSETED SHELF ANGLE

- Standard finishes: ZN, GRN
- Wt./C 141 Lbs. (63.9 kg)

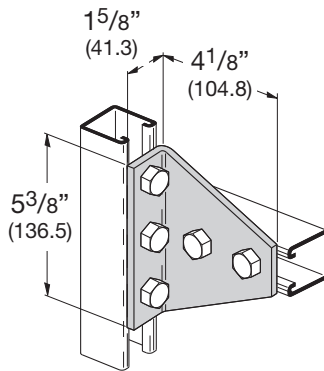

B126 FOUR HOLE GUSSETED THREE WAY SHELF ANGLE

- Standard finishes: ZN, GRN
- Wt./C 101 Lbs. (45.8 kg)

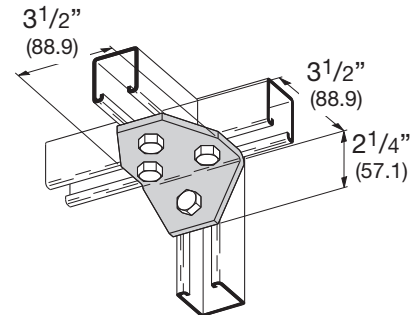

B127 FIVE HOLE GUSSETED THREE WAY SHELF ANGLE

- Standard finishes: ZN, GRN
- Wt./C 135 Lbs. (61.2 kg)

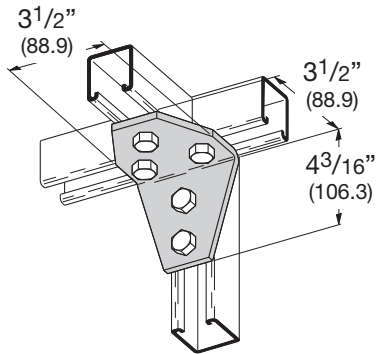

B503R SIX HOLE (RIGHT HAND) GUSSETED CORNER CONNECTION

- Standard finishes: ZN, GRN
- Wt./C 229 Lbs. (103.9 kg)

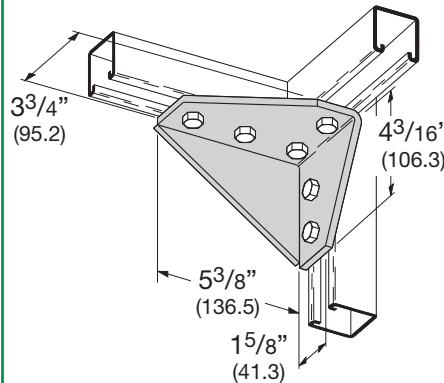

B503L SIX HOLE (LEFT HAND) GUSSETED CORNER CONNECTION

- Standard finishes: ZN, GRN
- Wt./C 229 Lbs. (103.9 kg)

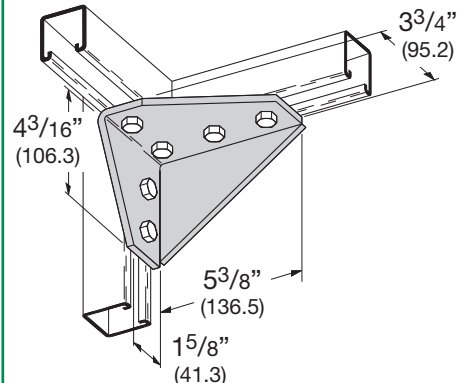

B663 SEVEN HOLE GUSSETED CORNER CONNECTION

- Standard finishes: ZN, GRN
- Wt./C 289 Lbs. (131.1 kg)

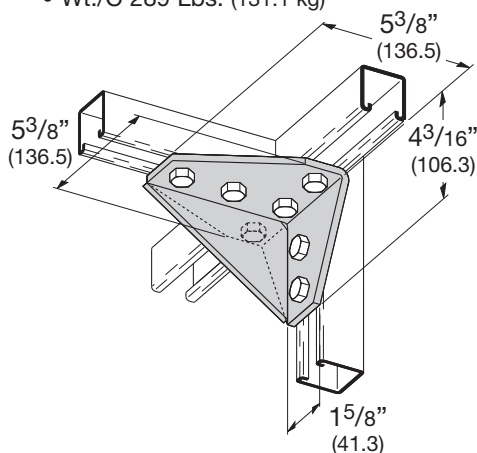

B371 TWO HOLE ADJUSTABLE CORNER ANGLE

- Standard finishes: ZN, GRN
- Wt./C 41 Lbs. (18.6 kg)

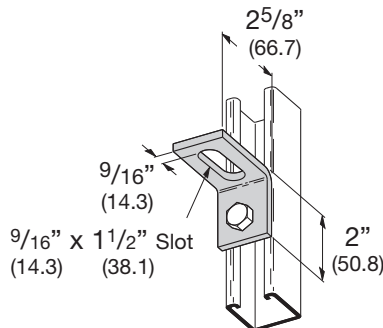

B372 TWO HOLE ADJUSTABLE CORNER ANGLE

- Standard finishes: ZN, GRN
- Wt./C 38 Lbs. (17.2 kg)

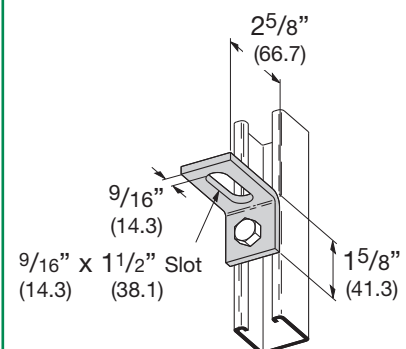

Strut Fittings

Reference page 72 for general fitting and standard finish specifications.

90° Angle Fittings

B496 TWO HOLE ADJUSTABLE CORNER ANGLE

- Standard finishes: ZN, GRN
- Wt./C 85 Lbs. (38.5 kg)

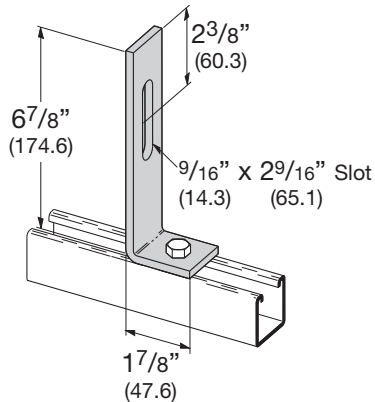

B496-1 TWO HOLE ADJUSTABLE CORNER ANGLE

- Standard finishes: ZN, GRN, HDG
- Wt./C 58 Lbs. (26.3 kg)

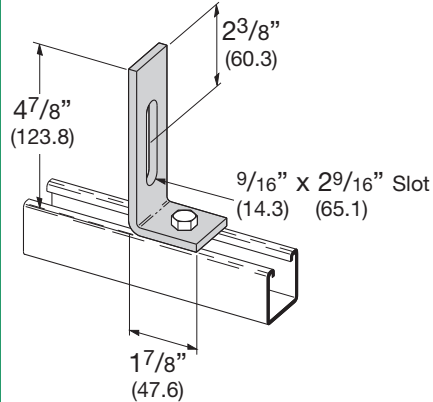

B371-2 THREE HOLE ADJUSTABLE CORNER ANGLE

- Standard finishes: ZN, GRN
- Wt./C 61 Lbs. (27.6 kg)

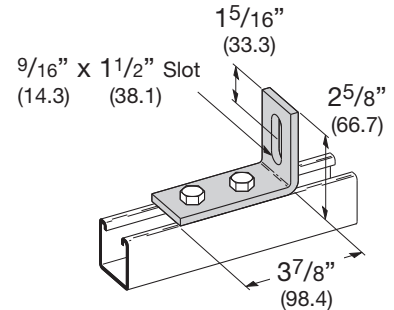

B104SH THREE HOLE ADJUSTABLE CORNER ANGLE

- Standard finishes: ZN, GRN
- Wt./C 68 Lbs. (30.8 kg)

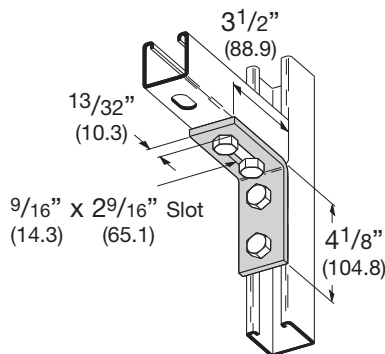

B461 TWO HOLE ADJUSTABLE CORNER ANGLE

- Standard finishes: ZN, GRN
- Wt./C 87 Lbs. (39.4 kg)

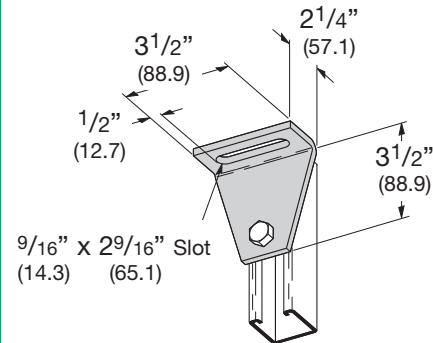

B112 FOUR HOLE ADJUSTABLE CORNER ANGLE

- Standard finishes: ZN, GRN
- Wt./C 180 Lbs. (81.6 kg)

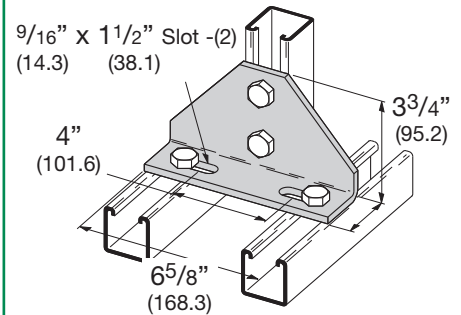

B113 FOUR HOLE ADJUSTABLE CORNER ANGLE

- Standard finishes: ZN, GRN
- Wt./C 256 Lbs. (116.1 kg)

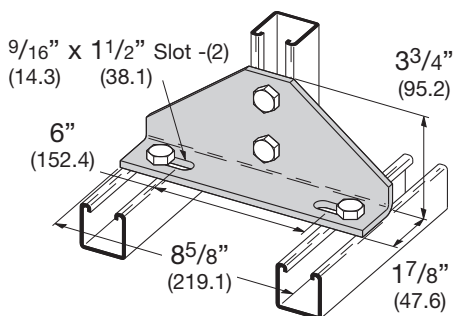

B109S TWO HOLE TAPPED CORNER ANGLE

- Standard finishes: ZN, GRN
- Wt./C 33 Lbs. (14.9 kg)

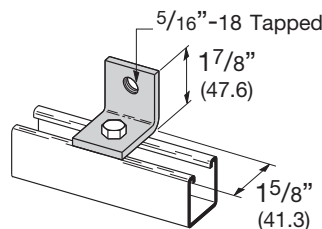

B521 TWO HOLE BUS DUCT ANGLE

- Standard finishes: ZN, GRN
- Wt./C 37 Lbs. (16.8 kg)

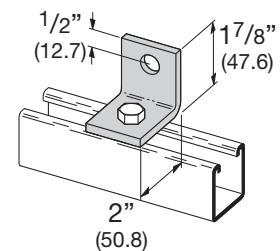

Reference page 72 for general fitting and standard finish specifications.

Angular Fittings

B147-B152 TWO HOLE OPEN ANGLE

- Standard finishes: ZN, GRN

Part No.	A	Wt./C	
		Lbs.	kg
B147	82 ¹ / ₂ °	63	(28.6)
B148	75°		
B149	67 ¹ / ₂ °		
B150	60°		
B151	52 ¹ / ₂ °		
B152	37 ¹ / ₂ °		

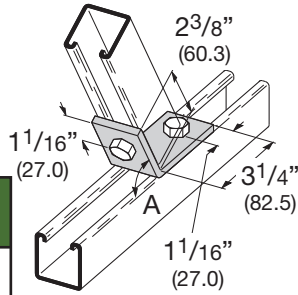

B243-B253 FOUR HOLE OPEN ANGLE

- Standard finishes: ZN, GRN

Part No.	A	Wt./C	
		Lbs.	kg
B243	71 ¹ / ₂ °	77	(34.9)
B244	15°		
B245	22 ¹ / ₂ °		
B246	30°		
B247	37 ¹ / ₂ °		
B248	45°		
B249	52 ¹ / ₂ °		
B250	60°		
B251	67 ¹ / ₂ °		
B252	75°		
B253	82 ¹ / ₂ °		

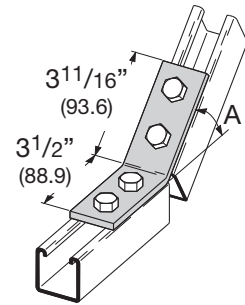

B162-B165 TWO HOLE OPEN ANGLE

- Standard finishes: ZN, GRN

Part No.	A	Wt./C	
		Lbs.	kg
B162	30°	59	(26.7)
B163	22 ¹ / ₂ °		
B164	15°		
B165	7 ¹ / ₂ °		

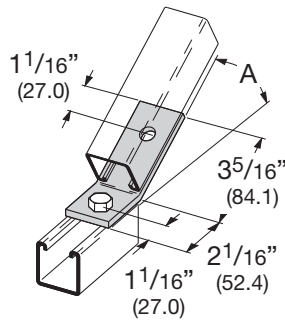

B322-B332 TWO HOLE OPEN SHORT ANGLE

- Standard finishes: ZN, GRN

Part No.	A	Wt./C	
		Lbs.	kg
B322	71 ¹ / ₂ °	35	(15.9)
B323	15°		
B324	22 ¹ / ₂ °		
B325	30°		
B326	37 ¹ / ₂ °		
B327	45°		
B328	52 ¹ / ₂ °		
B329	60°		
B330	67 ¹ / ₂ °		
B331	75°		
B332	82 ¹ / ₂ °		

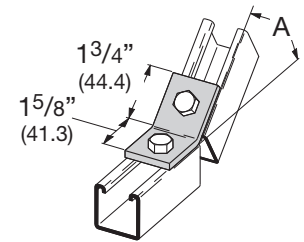

B154 TWO HOLE OPEN ANGLE

- Standard finishes: ZN, GRN, SS4
- Wt./C 58 Lbs. (26.3 kg)

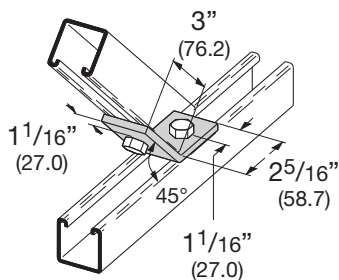

B522 THREE HOLE 95° OPEN ANGLE FITTING

- Standard finishes: ZN, GRN
- Wt./C 54 Lbs. (24.5 kg)

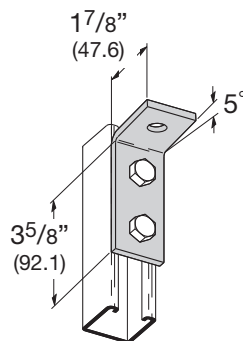

B488 TWO HOLE LEG CONNECTION

- Standard finishes: ZN, GRN
- Wt./C 100 Lbs. (45.3 kg)

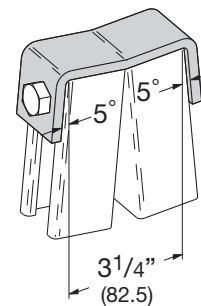

Reference page 72 for general fitting and standard finish specifications.

B156 - B161 TWO HOLE CLOSED ANGLE

- Standard finishes: ZN, GRN

Part No.	A	Wt./C	
		Lbs.	kg
B156	82 ¹ / ₂ °	56	(25.4)
B157	75°		
B158	67 ¹ / ₂ °		
B159	60°		
B160	52 ¹ / ₂ °		
B161	37 ¹ / ₂ °		

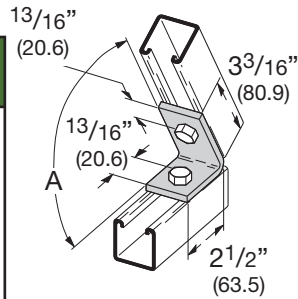

B155 TWO HOLE CLOSED ANGLE

- Standard finishes: ZN, GRN, HDG, SS4
- Wt./C 63 Lbs. (28.6 kg)

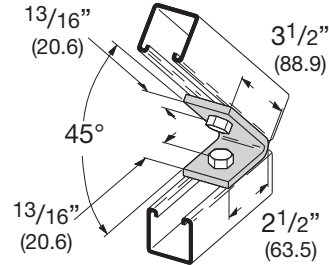

B363 - B369 FOUR HOLE CLOSED ANGLE

- Standard finishes: ZN, GRN

Part No.	A	Wt./C	
		Lbs.	kg
B363	82 ¹ / ₂ °	95	(43.1)
B364	75°		
B365	67 ¹ / ₂ °		
B366	60°		
B367	52 ¹ / ₂ °		
B368	45°		
B369	37 ¹ / ₂ °		

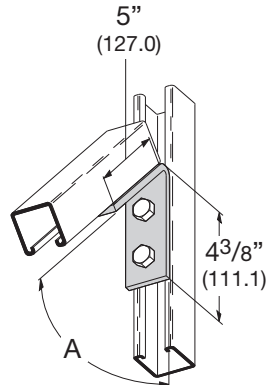

B335-2 SERIES THREE HOLE ADJUSTABLE HINGE

- OSHPD approved for Seismic Zone 4
- Standard finishes: ZN, GRN

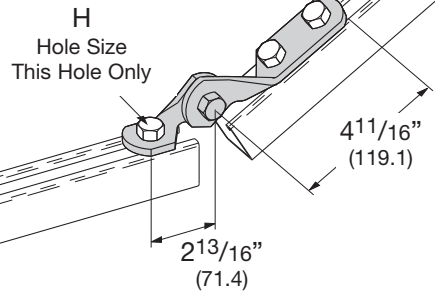

Part No. & Size	Hole Size H		Wt./C	
	H		Lbs.	kg
B335-2-3/8	7/16"	(11.1)	96	(43.2)
B335-2-1/2	9/16"	(14.3)	94	(42.3)
B335-2-5/8	11/16"	(17.4)	92	(41.4)
B335-2-3/4	13/16"	(20.6)	90	(40.5)

B335 FOUR HOLE ADJUSTABLE HINGE

- Standard finishes: ZN, GRN
- Wt./C 110 Lbs. (49.9 kg)

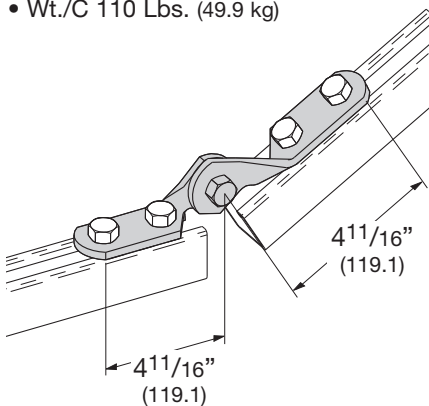

B335V TWO HOLE HALF HINGE

- Standard finishes: ZN, GRN

Part No. & Size	Hole Size H		Wt./C	
	H		Lbs.	kg
B335V-1/2	9/16"	(14.3)	53	(24.1)
B335V-5/8	11/16"	(17.4)	54	(24.5)
B335V-3/4	13/16"	(20.6)	55	(24.9)

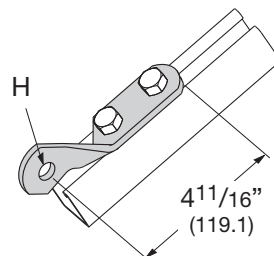

B335-1 TWO HOLE ADJUSTABLE HINGE

- Standard finishes: ZN, GRN
- Wt./C 78 Lbs. (35.4 kg)

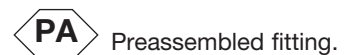
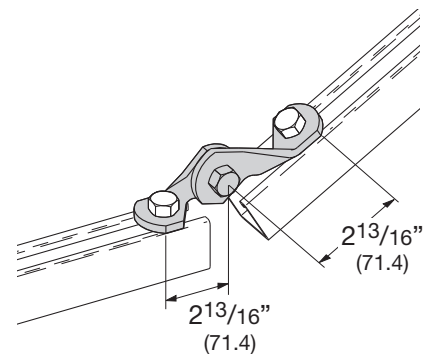

Reference page 72 for general fitting and standard finish specifications.

Angular Fittings

B634 SINGLE CHANNEL ADJUSTABLE BRACE

- Standard finishes: ZN, GRN
- Wt./C 306 Lbs. (138.8 kg)

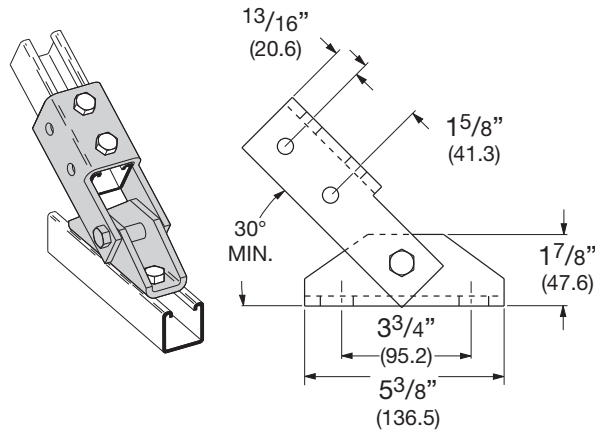

B635 DOUBLE CHANNEL ADJUSTABLE BRACE

- Standard finishes: ZN, GRN
- Wt./C 518 Lbs. (234.9 kg)

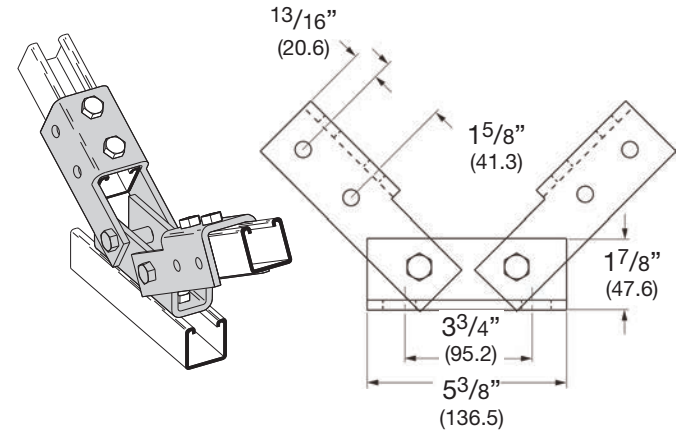

B650 SERIES SEISMIC RETROFIT BRACKET

- OSHPD approved for Seismic Zone 4.
- Available for 3/8", 1/2", 5/8", and 3/4" threaded rods.
- Allows installer to easily brace existing trapeze supports.
- Includes: Bracket, B129 plate, & key. Hardware sold separately.
- Standard finish: ZN, GRN

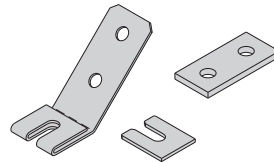

Part No. & Size	For Rod Size	TL		LL		Wt./C	
		Lbs.	kN	Lbs.	kN	Lbs.	kg
B650-3/8	3/8"	1100	(4.89)	1100	(4.89)	92	(41.4)
B650-1/2	1/2"	1500	(6.67)	1500	(6.67)	97	(43.6)
B650-5/8	5/8"	1500	(6.67)	1500	(6.67)	95	(42.7)
B650-3/4	3/4"	1500	(6.67)	1500	(6.67)	107	(48.5)

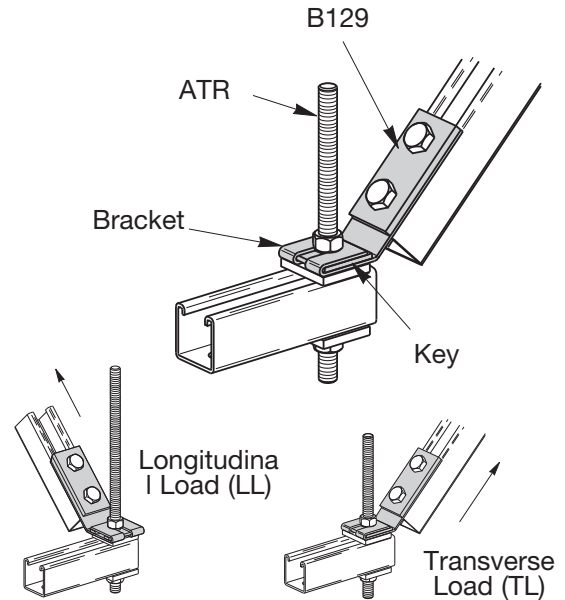

B633 ADJUSTABLE SEISMIC HINGE FITTING

- B633-1/2 thru B633-7/8 - OSHPD approved for Seismic Zone 4.
- Use 1/2" Bolt & Channel Nut on two hole side of Connector Fitting (Torque to 50 ft.-lbs.)
- Allows for swivel in two planes.
- Standard finish: ZN

Part No. & Size	A		B		Hole Size H		Wt./C	
	Lbs.	kN	Lbs.	kN	Lbs.	kN	Lbs.	kg
B633-1/2	31/2"	(82.5)	15/8"	(41.3)	9/16"	(14.3)	92	(41.4)
B633-5/8	31/2"	(82.5)	15/8"	(41.3)	11/16"	(17.4)	97	(43.6)
B633-3/4	31/2"	(82.5)	15/8"	(41.3)	13/16"	(20.6)	95	(42.7)
B633-7/8	39/16"	(90.5)	2"	(50.8)	15/16"	(23.8)	107	(48.5)
B633-1	39/16"	(90.5)	2"	(50.8)	11/16"	(27.0)	120	(54.0)
B633-11/8	39/16"	(90.5)	2"	(50.8)	13/16"	(30.2)	104	(47.2)
B633-11/4	37/8"	(98.4)	21/4"	(57.1)	15/16"	(33.3)	114	(51.7)

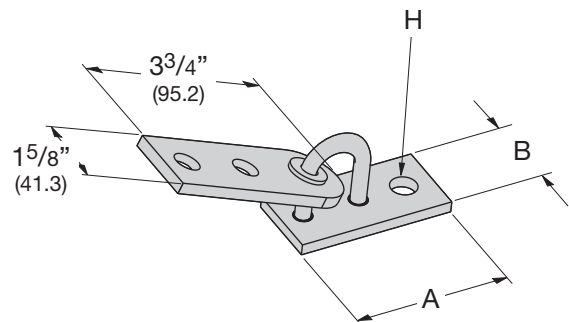

Reference page 72 for general fitting and standard finish specifications.

B261 - TWO HOLE 45° KNEE BRACE

- Standard finishes: ZN, GRN
- Design load determined by testing using a B335 hinged corner connection.
- Load ratings are for brace members only. Do not exceed allowable beam or column loads for strut channels.
- Safety Factor of 3

Part No.	A	(A)	B	(B)	Design Load		Wt./C	
					Lbs.	kN	Lbs.	kg
B261-8	8"	(203.2)	7 ³ / ₈ "	(187.3)	1500	(6.67)	119	(54.0)
B261-12	12"	(304.8)	10 ¹ / ₈ "	(257.2)	1020	(4.54)	165	(74.8)
B261-16	16 ⁵ / ₈ "	(422.3)	13 ³ / ₈ "	(339.7)	530	(2.36)	218	(98.9)
B261-18	18"	(457.2)	14 ⁷ / ₁₆ "	(366.7)	450	(2.00)	234	(106.1)
B261-24	24"	(609.6)	18 ¹¹ / ₁₆ "	(474.7)	250	(1.11)	303	(137.4)
B261-36	36"	(914.4)	27 ³ / ₁₆ "	(690.6)	110	(.49)	441	(200.0)

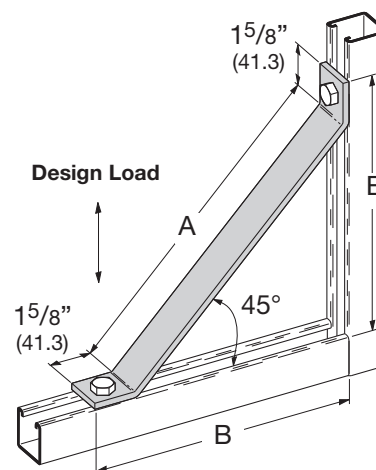

B631 - TWO HOLE 45° TUBING KNEE BRACE

- 1" (25.4) Square steel tubing
- Material: ASTM A513
- Standard finishes: ZN, GRN
- Design load determined by testing using a B335 hinged corner connection.
- Load ratings are for brace members only. Do not exceed allowable beam or column loads for strut channels.
- Safety Factor of 3

Part No.	A	(A)	Design Load		Wt./C	
			Lbs.	kN	Lbs.	kg
B631-18	18"	(457.2)	1500	(6.67)	145	(65.8)
B631-24	24"	(609.6)	1500	(6.67)	186	(84.4)
B631-30	30"	(762.0)	1500	(6.67)	225	(102.0)
B631-36	36"	(914.4)	1500	(6.67)	266	(120.6)
B631-42	42"	(1066.8)	1230	(5.47)	307	(139.2)
B631-48	48"	(1219.2)	940	(4.18)	348	(157.8)
B631-54	54"	(1371.6)	740	(3.29)	389	(176.4)
B631-60	60"	(1524.0)	600	(2.67)	430	(195.0)
B631-72	72"	(1828.8)	420	(1.87)	508	(230.4)
B631-84	84"	(2133.6)	310	(1.38)	589	(267.2)
B631-96	96"	(2438.4)	240	(1.07)	669	(303.5)

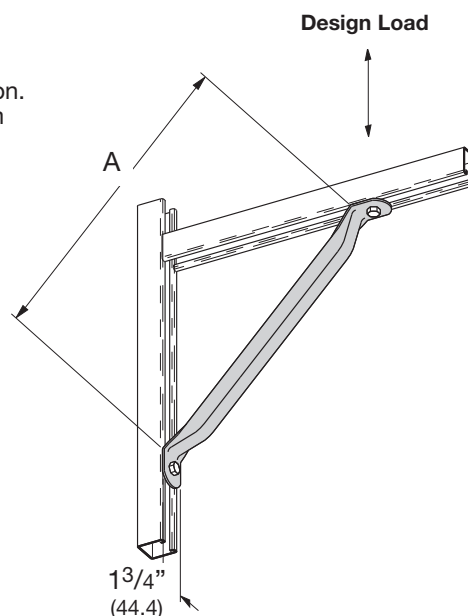

B632 - TWO HOLE STRAIGHT TUBING BRACE

- 1" (25.4) Square steel tubing
- Material: ASTM A513
- Standard finishes: ZN, GRN

Part No.	A	(A)	Wt./C	
			Lbs.	kg
B632-18	18"	(457.2)	133	(60.3)
B632-24	24"	(609.6)	174	(78.9)
B632-30	30"	(762.0)	215	(97.5)
B632-36	36"	(914.4)	256	(116.1)
B632-42	42"	(1066.8)	295	(133.8)
B632-48	48"	(1219.2)	335	(151.9)
B632-54	54"	(1371.6)	380	(172.3)
B632-60	60"	(1524.0)	420	(190.5)
B632-72	72"	(1828.8)	500	(226.8)
B632-84	84"	(2133.6)	585	(265.3)
B632-96	96"	(2438.4)	670	(303.9)

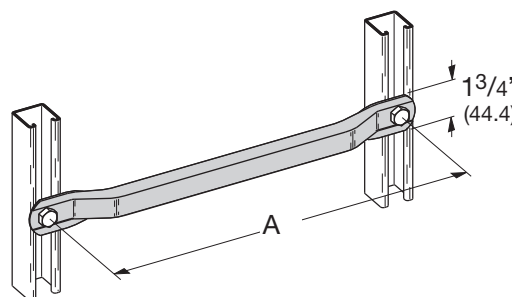

Reference page 72 for general fitting and standard finish specifications.

Clevis Fittings

B169 TWO HOLE SPLICE CLEVIS FOR B52

- Standard finishes: ZN, GRN
- Wt./C 84 Lbs. (38.1 kg)

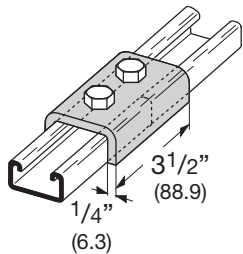

B168 THREE HOLE SPLICE CLEVIS FOR B52

- Standard finishes: ZN, GRN
- Wt./C 126 Lbs. (57.1 kg)

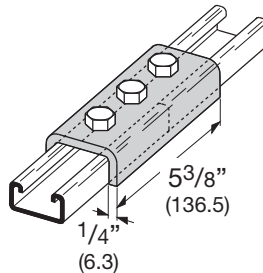

B167 FOUR HOLE SPLICE CLEVIS FOR B52

- Standard finishes: ZN, GRN
- Wt./C 178 Lbs. (80.7 kg)

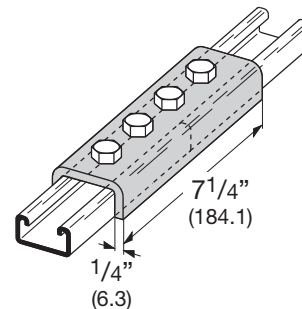

B170 TWO HOLE SPLICE CLEVIS FOR B22 OR B52A

- Standard finishes: ZN, GRN
- Wt./C 123 Lbs. (55.8 kg)

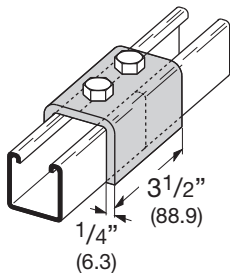

B171 THREE HOLE SPLICE CLEVIS FOR B22 OR B52A

- Standard finishes: ZN, GRN
- Wt./C 195 Lbs. (88.4 kg)

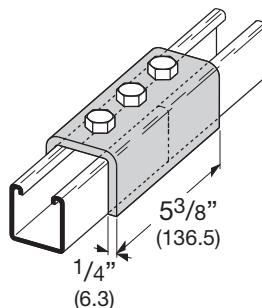

B172 FOUR HOLE SPLICE CLEVIS FOR B22 OR B52A

- Standard finishes: ZN, GRN
- Wt./C 266 Lbs. (120.6 kg)

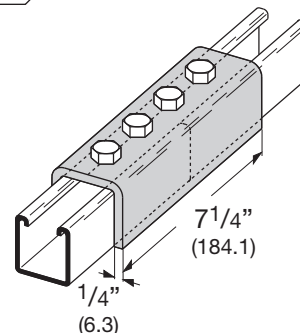

B172-12 FOUR HOLE SPLICE CLEVIS FOR B12

- Standard finishes: ZN, GRN
- Wt./C 326 Lbs. (147.8 kg)

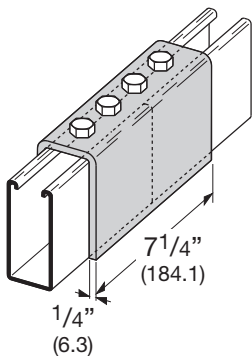

B172-22A FOUR HOLE SPLICE CLEVIS FOR B11 OR B22A

- Standard finishes: ZN, GRN
- Wt./C 406 Lbs. (184.1 kg)

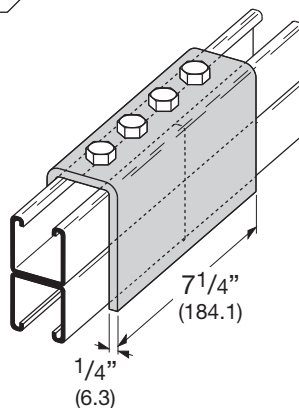

B450 U-WASHER

- Material: ASTM A1011 HSLAS Gr. 50
- Standard finishes: ZN, GRN

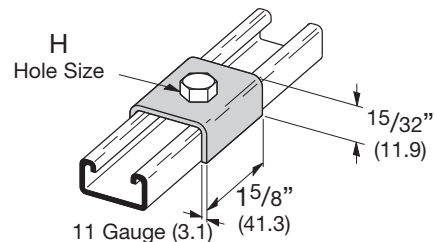

Part No. & Size	Hole Size H	Wt./C Lbs. kg
B450-1/4	5/16" (7.9)	14 (6.3)
B450-3/8	7/16" (11.1)	14 (6.3)
B450-1/2	9/16" (14.3)	13 (5.8)
B450-5/8	11/16" (17.4)	13 (5.8)
B450-3/4	13/16" (20.6)	13 (5.8)

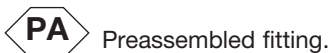

Reference page 72 for general fitting and standard finish specifications.

B527 THREE HOLE OFFSET PLATE CONNECTION

- Standard finishes: ZN, GRN
- Wt./C 54 Lbs. (24.5 kg)

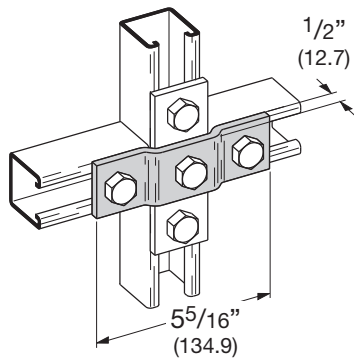

B116-52 THREE HOLE U-SUPPORT

- Standard finishes: ZN, GRN
- Wt./C 70 Lbs. (31.7 kg)

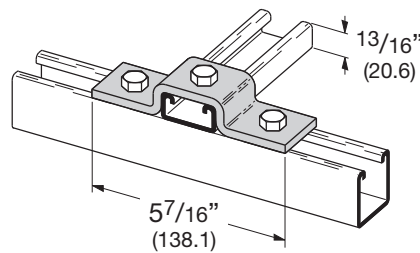

B116-42 THREE HOLE U-SUPPORT

- Standard finishes: ZN, GRN
- Wt./C 75 Lbs. (34.0 kg)

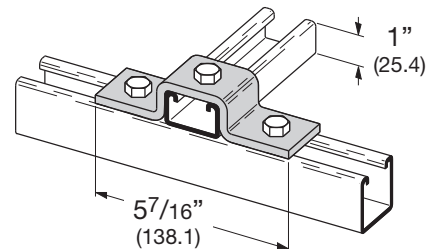

B116-32 THREE HOLE U-SUPPORT

- Standard finishes: ZN, GRN
- Wt./C 84 Lbs. (38.1 kg)

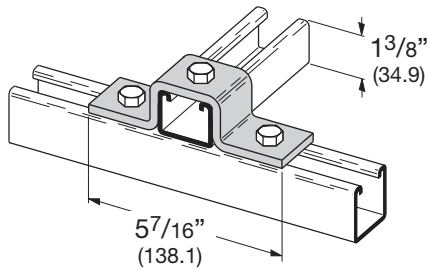

B116-32A THREE HOLE U-SUPPORT

- Standard finishes: ZN, GRN
- Wt./C 116 Lbs. (52.6 kg)

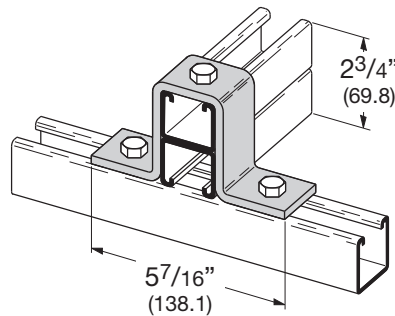

B116-12 THREE HOLE U-SUPPORT

- Standard finishes: ZN, GRN
- Wt./C 108 Lbs. (49.0 kg)

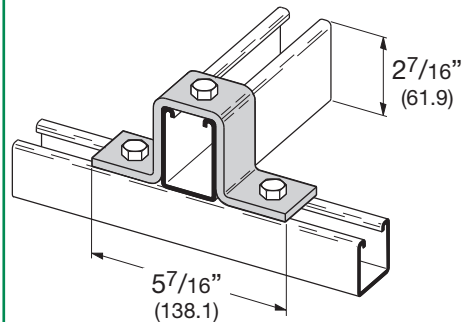

B107 FIVE HOLE U-SUPPORT

- Standard finishes: ZN, GRN, HDG
- Wt./C 85 Lbs. (38.5 kg)

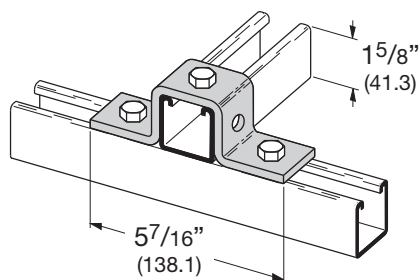

B107-22A THREE HOLE U-SUPPORT

- Standard finishes: ZN, GRN
- Wt./C 126 Lbs. (57.1 kg)

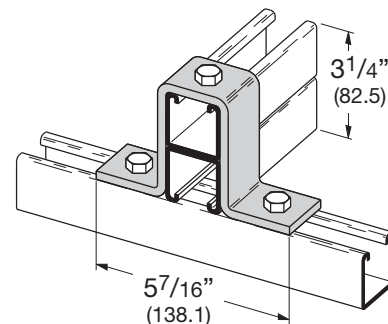

B588 THREE HOLE U-SUPPORT

- Standard finishes: ZN, GRN
- Wt./C 157 Lbs. (71.2 kg)

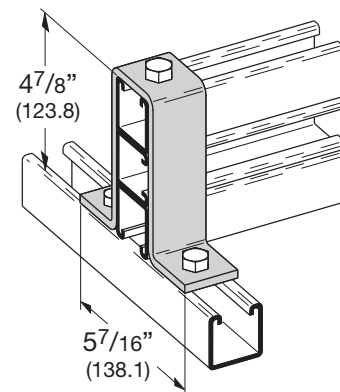

PA Preassembled fitting.

Reference page 72 for general fitting and standard finish specifications.

'U' Fittings

B412 THREE HOLE OFFSET U-SUPPORT

- Standard finishes: ZN, GRN
- Wt./C 89 Lbs. (40.3 kg)

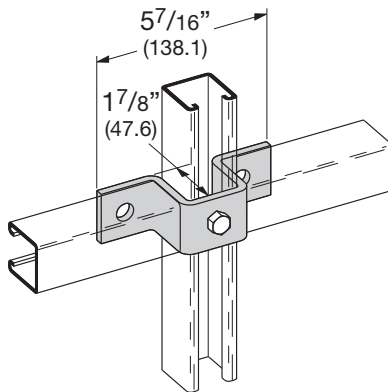

B107S FIVE HOLE U-SUPPORT

- Material: 7 Gauge (4.5)
ASTM A1011 33,000 PSI min. yield
- Standard finishes: ZN, GRN
- Wt./C 51 Lbs. (23.1 kg)

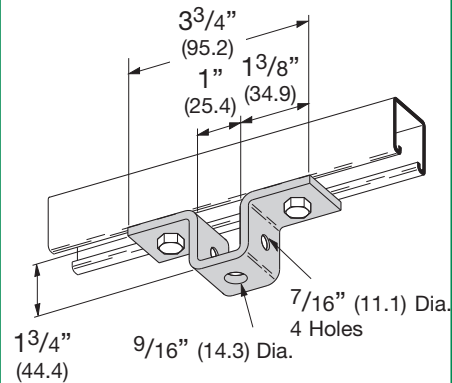

B596 THREE HOLE SWIVEL CLEVIS

- Material: 7 Gauge (4.5)
- Standard finishes: ZN, GRN
- Wt./C 53 Lbs. (24.0 kg)

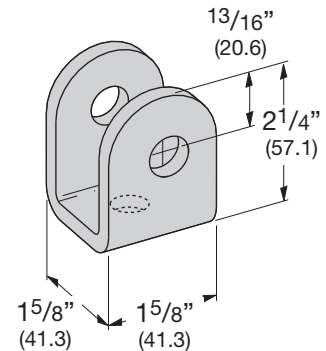

B578 THREE HOLE LIGHT-WEIGHT U-SUPPORT

- Material: 10 Gauge (3.4)
ASTM A1011 HSLAS Gr. 50
- Standard finishes: ZN, GRN
- Wt./C 18 Lbs. (8.1 kg)

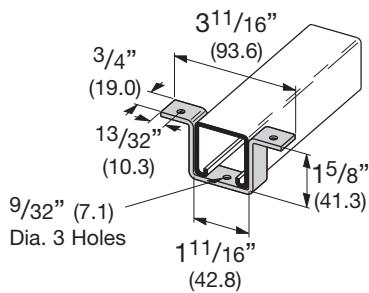

B594 FIVE HOLE U-SUPPORT

- Standard finishes: ZN, GRN
- Wt./C 106 Lbs. (48.1 kg)

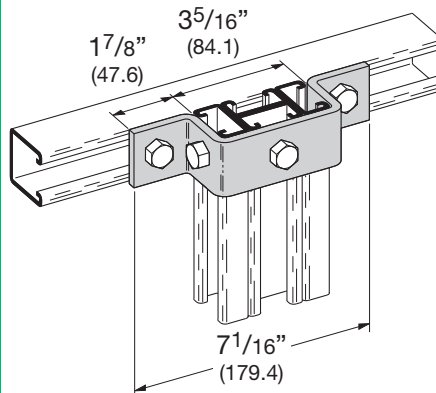

B266 SIX HOLE U-SUPPORT

- Standard finishes: ZN, GRN
- Wt./C 105 Lbs. (47.6 kg)

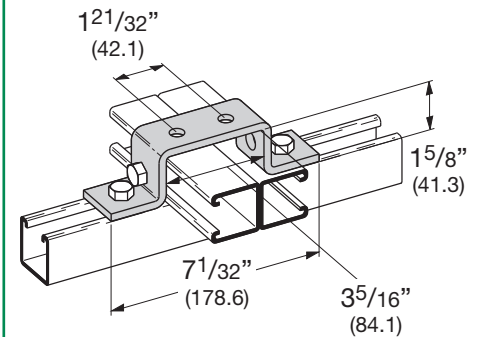

B425 SIX HOLE U-SUPPORT

- Standard finishes: ZN, GRN
- Wt./C 167 Lbs. (75.7 kg)

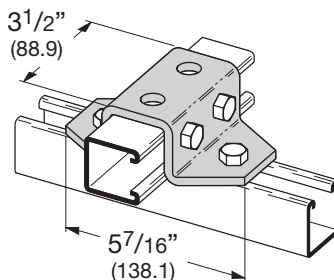

B581 EIGHT HOLE U-SUPPORT

- Standard finishes: ZN, GRN
- Wt./C 201 Lbs. (91.2 kg)

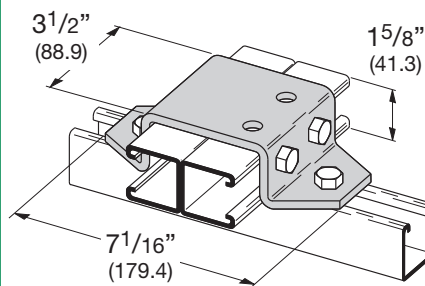

B519 EIGHT HOLE U-SUPPORT

- Standard finishes: ZN, GRN
- Wt./C 266 Lbs. (102.5 kg)

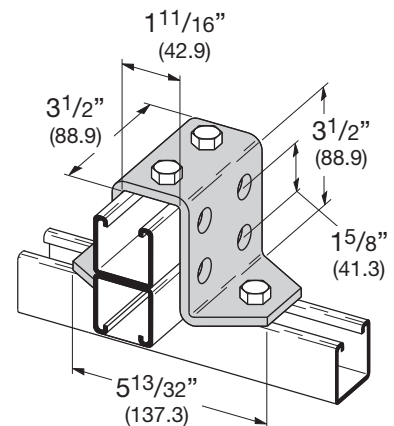

Reference page 72 for general fitting and standard finish specifications.

B333 SLOTTED THREE HOLE U-SUPPORT FOR B22

- Standard finishes: ZN, GRN

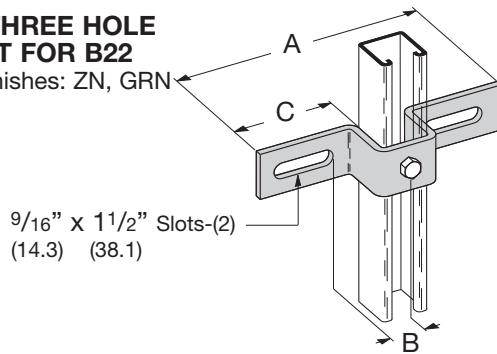

Part No.	A		B		C		Wt./C	
	(A)	(A)	(B)	(B)	(C)	(C)	Lbs.	kg
B333-1	7 ¹ / ₂ "	(190.5)	1 ⁵ / ₁₆ "	(33.3)	2 ⁷ / ₈ "	(73.0)	103	(46.7)
B333-2	8 ¹ / ₂ "	(215.9)	1 ¹⁵ / ₁₆ "	(49.2)	3 ³ / ₈ "	(85.7)	115	(52.1)
B333-3	10 ³ / ₈ "	(263.5)	2 ⁷ / ₈ "	(73.0)	4 ⁵ / ₁₆ "	(109.5)	135	(61.2)

B451 SLOTTED THREE HOLE U-SUPPORT WITH GUSSET FOR B22

- Consists of B333-1, 2, or 3 with gusset plate welded on back.
- Material: ASTM A1011 HSLAS Gr. 50
- Standard finishes: ZN, GRN

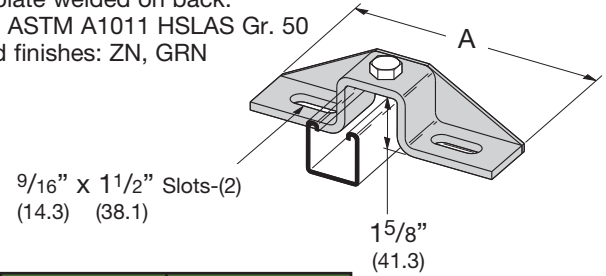

Part No.	A		Wt./C	
	(A)	(A)	Lbs.	kg
B451-1	7 ¹ / ₂ "	(190.5)	137	(62.1)
B451-2	8 ¹ / ₂ "	(215.9)	156	(70.7)
B451-3	10 ³ / ₈ "	(263.5)	172	(78.0)

B408 TWO HOLE BUS DUCT CLEVIS

- Standard finishes: ZN, GRN

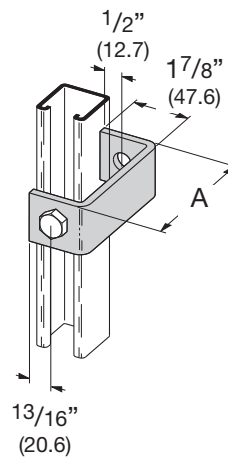

Part No.	A		Wt./C	
	(A)	(A)	Lbs.	kg
B408-1	2 ¹³ / ₃₂ "	(61.1)	58	(26.3)
B408-2	3 ²⁵ / ₃₂ "	(96.0)	76	(34.5)
B408-3	4 ³ / ₄ "	(762.0)	88	(39.9)

B358 TWO HOLE CLEVIS

- Standard finishes: ZN, GRN

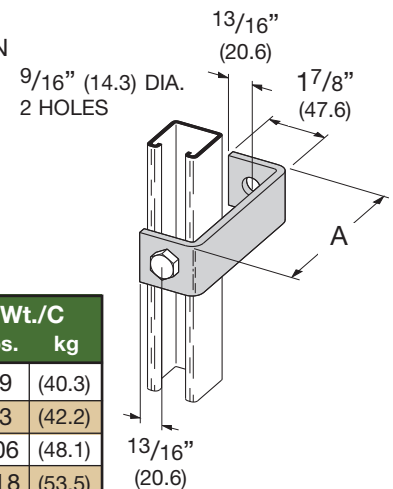

Part No.	A		Wt./C	
	(A)	(A)	Lbs.	kg
B358-4	4"	(101.6)	89	(40.3)
B358-5	5"	(127.0)	93	(42.2)
B358-6	6"	(152.4)	106	(48.1)
B358-7	7"	(177.8)	118	(53.5)
B358-8	8"	(203.2)	132	(59.9)

B173 FOUR HOLE CLEVIS

- Standard finishes: ZN, GRN
- Wt./C 71 Lbs. (32.2 kg)

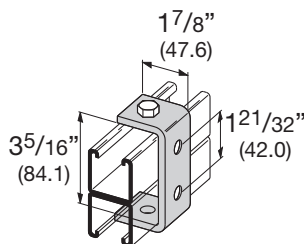

B595 THREE HOLE CLEVIS

- Standard finishes: ZN, GRN
- Wt./C 75 Lbs. (34.0 kg)

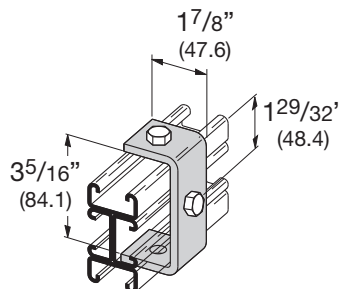

B405 THREE HOLE SUSPENSION CLEVIS

- Standard finishes: ZN, GRN
- Wt./C 75 Lbs. (34.0 kg)

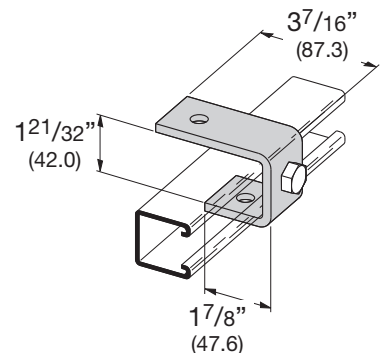

Reference page 72 for general fitting and standard finish specifications.

'U' Fittings

B398-1 THREE HOLE CUP SUPPORT

- Standard finishes: ZN, GRN
- Wt./C 73 Lbs. (33.1 kg)

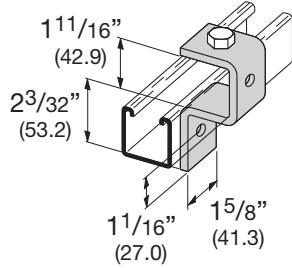

B415 TWO HOLE BUS DUCT CONNECTION

- Standard finishes: ZN, GRN
- Wt./C 56 Lbs. (25.4 kg)

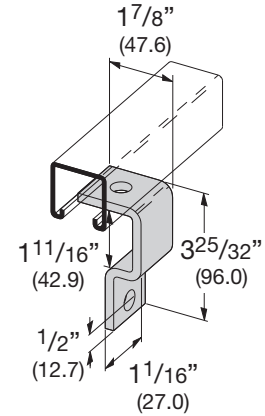

B400 THREE STUD RING CONNECTION

- 1/2"-13 stud protrudes 1" (25.4mm)
- Standard finishes: ZN
- Wt./C 85 Lbs. (38.5 kg)

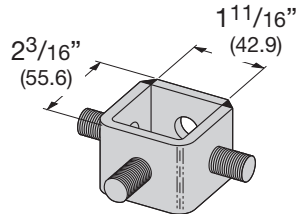

B400-1 ONE STUD RING CONNECTION

- 1/2"-13 stud protrudes 1" (25.4mm)
- Standard finishes: ZN
- Wt./C 53 Lbs. (24.0 kg)

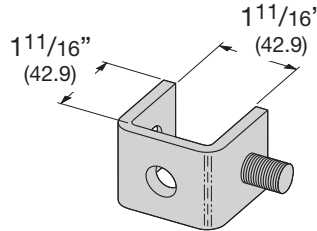

B400-2 ONE STUD RING CONNECTION

- 1/2"-13 stud protrudes 1" (25.4mm)
- Standard finishes: ZN
- Wt./C 40 Lbs. (18.1 kg)

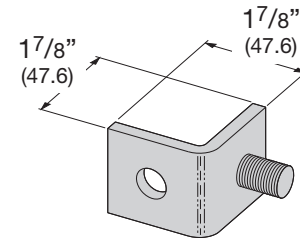

B400-3 TWO STUD RING CONNECTION

- 1/2"-13 stud protrudes 1" (25.4mm)
- Standard finishes: ZN
- Wt./C 59 Lbs. (26.7 kg)

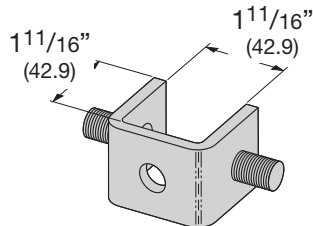

B400-4 TWO STUD RING CONNECTION

- 1/2"-13 stud protrudes 1" (25.4mm)
- Standard finishes: ZN
- Wt./C 59 Lbs. (26.7 kg)

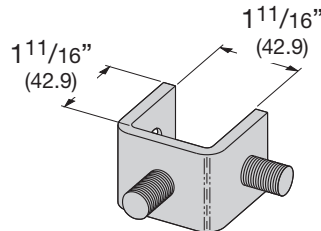

B536 TAPPED U-SUPPORT

- Standard finishes: ZN
- Wt./C 87 Lbs. (39.4 kg)

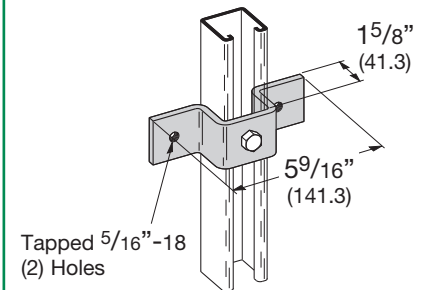

Tapped 5/16"-18
(2) Holes

B526
TWO HOLE
OFFSET Z-SUPPORT

- Standard finishes: ZN, GRN
- Wt./C 38 Lbs. (17.2 kg)

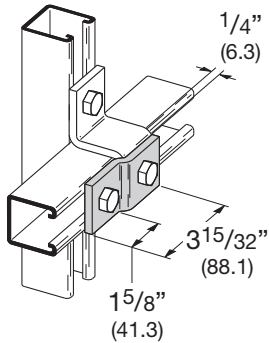

B106-52
TWO HOLE
Z-SUPPORT FOR B52

- Standard finishes: ZN, GRN
- Wt./C 40 Lbs. (18.1 kg)

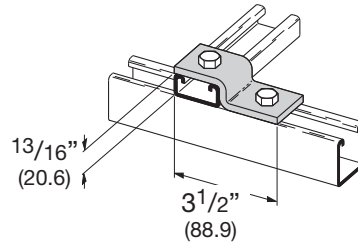

B106-42
TWO HOLE
Z-SUPPORT FOR B42

- Standard finishes: ZN, GRN
- Wt./C 44 Lbs. (20.0 kg)

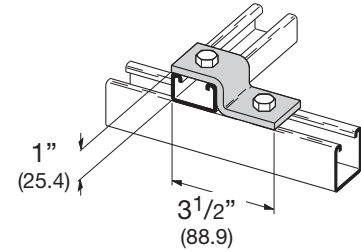

B106-32
TWO HOLE
Z-SUPPORT FOR B32

- Standard finishes: ZN, GRN
- Wt./C 51 Lbs. (23.1 kg)

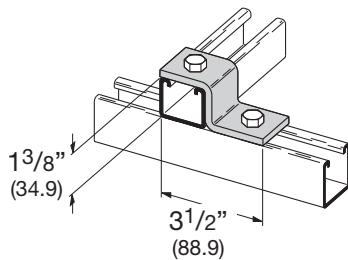

B106-12
TWO HOLE
Z-SUPPORT FOR B12

- Standard finishes: ZN, GRN
- Wt./C 63 Lbs. (28.6 kg)

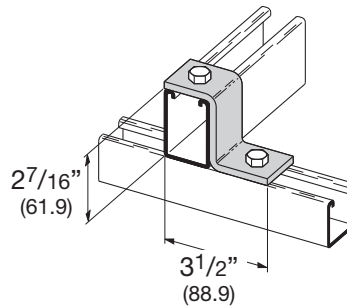

B105
THREE HOLE
Z-SUPPORT FOR B22

- Standard finishes: ZN, GRN, HDG
- Wt./C 51 Lbs. (23.1 kg)

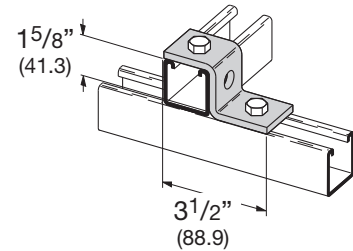

B110
THREE HOLE
Z-SUPPORT FOR B11

- Standard finishes: ZN, GRN
- Wt./C 70 Lbs. (31.7 kg)

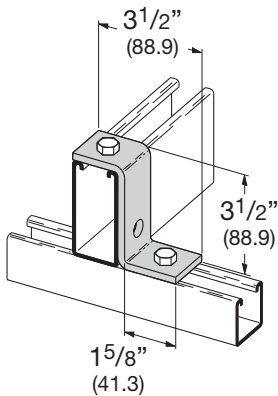

B586
TWO HOLE
Z-SUPPORT

- Standard finishes: ZN, GRN
- Wt./C 90 Lbs. (40.8 kg)

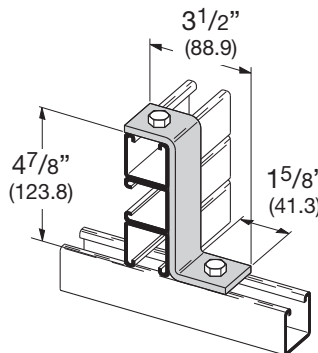

B108
TWO HOLE
OFFSET Z-SUPPORT

- Standard finishes: ZN, GRN
- Wt./C 55 Lbs. (24.9 kg)

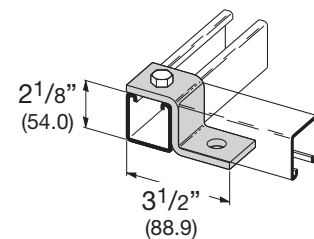

Reference page 72 for general fitting and standard finish specifications.

'Z' Fittings

B387 TWO HOLE Z-BUS DUCT CONNECTION

- Standard finishes: ZN, GRN

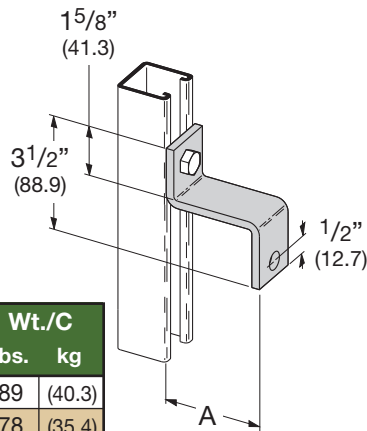

Part No.	A	(A)	Wt./C	
			Lbs.	kg
B387	4 ³ / ₄ "	(120.6)	89	(40.3)
B387-1	3 ²⁵ / ₃₂ "	(96.0)	78	(35.4)
B387-2	2 ¹³ / ₃₂ "	(61.1)	62	(28.1)

B407 TWO HOLE Z-SUPPORT

- Standard finishes: ZN, GRN

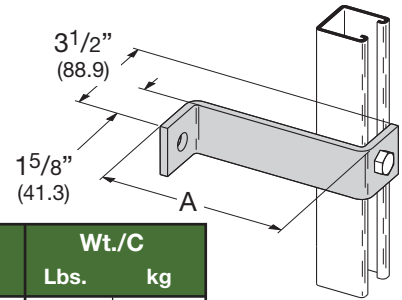

Part No.	A	(A)	Wt./C	
			Lbs.	kg
B407-4	4"	(101.6)	77	(34.9)
B407-5	5"	(127.0)	95	(43.1)
B407-6	6"	(152.4)	98	(44.4)
B407-7	7"	(177.8)	105	(47.6)
B407-8	8"	(203.2)	120	(54.4)
B407-9 ⁵ / ₈	9 ⁵ / ₈ "	(244.5)	138	(62.6)

B534 TAPPED Z-SUPPORT

- Standard finishes: ZN
- Wt./C 51 Lbs. (23.1 kg)

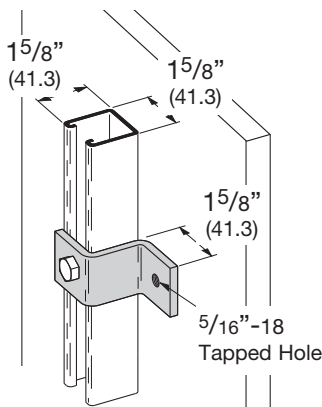

B535 TAPPED Z-SUPPORT

- Standard finishes: ZN
- Wt./C 50 Lbs. (22.7 kg)

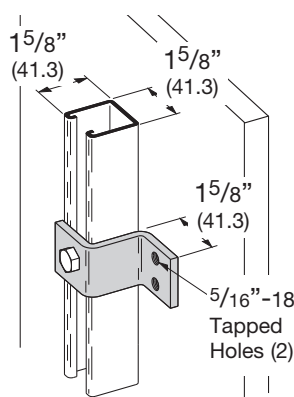

B111 THREE HOLE SHEATH CORNER CONNECTION

- Standard finishes: ZN, GRN
- Wt./C 68 Lbs. (30.8 kg)

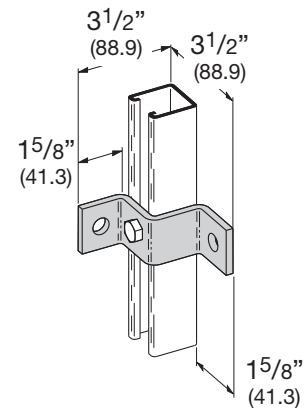

B538 TAPPED CORNER CONNECTION

- Standard finishes: ZN
- Wt./C 71 Lbs. (32.2 kg)

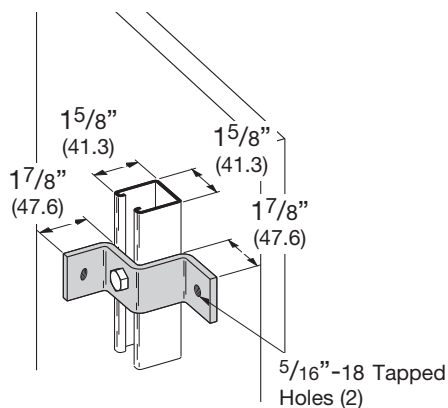

B539 TAPPED CORNER CONNECTION

- Standard finishes: ZN
- Wt./C 68 Lbs. (30.8 kg)

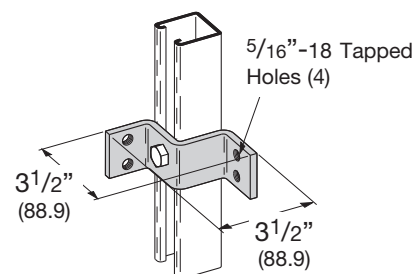

B410-52 CHANNEL HANGER BRACKET FOR B52

- Material: 11 Gauge (3.0)
ASTM A1011 HSLAS Gr. 50
- Standard finishes: ZN, GRN
- Wt./C 6.7 Lbs. (3.0 kg)

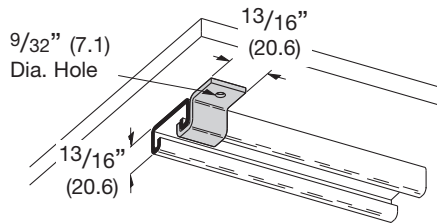

B410-32 CHANNEL HANGER BRACKET FOR B32

- Material: 11 Gauge (3.0)
ASTM A1011 HSLAS Gr. 50
- Standard finishes: ZN, GRN
- Wt./C 8.3 Lbs. (3.7 kg)

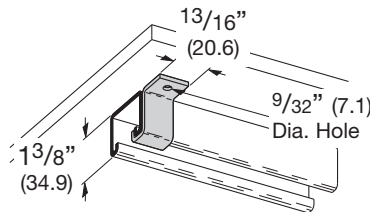

B410-22 CHANNEL HANGER BRACKET FOR B22

- Material: 11 Gauge (3.0)
ASTM A1011 HSLAS Gr. 50
- Standard finishes: ZN, GRN
- Wt./C 9 Lbs. (4.1 kg)

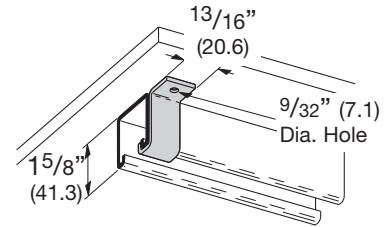

B410-12 CHANNEL HANGER BRACKET FOR B12

- Material: 11 Gauge (3.0)
ASTM A1011 HSLAS Gr. 50
- Standard finishes: ZN, GRN
- Wt./C 11.2 Lbs. (5.1 kg)

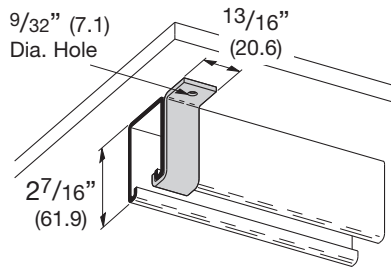

B410-11 CHANNEL HANGER BRACKET FOR B11

- Material: 11 Gauge (3.0)
ASTM A1011 HSLAS Gr. 50
- Standard finishes: ZN, GRN
- Wt./C 13.4 Lbs. (6.1 kg)

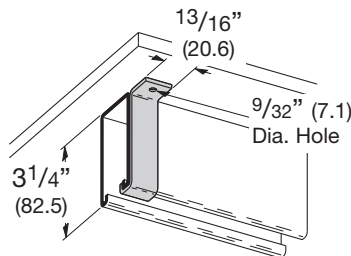

B580 FIVE HOLE GUSSETED Z-SUPPORT

- Standard finishes: ZN, GRN
- Wt./C 100 Lbs. (45.3 kg)

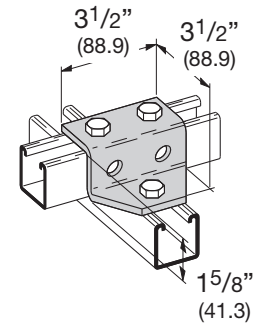

B515 ADJUSTABLE OFFSET GUSSETED Z-SUPPORT

- Standard finishes: ZN, GRN
- Wt./C 93 Lbs. (42.2 kg)

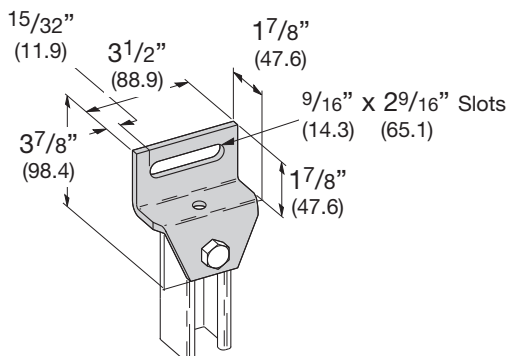

B428 EIGHT HOLE GUSSETED CORNER CONNECTION

- Standard finishes: ZN, GRN
- Wt./C 203 Lbs. (92.1 kg)

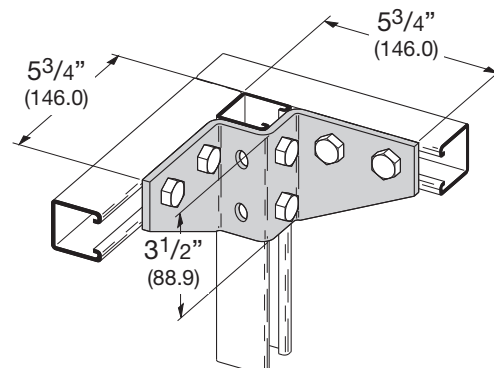

Reference page 72 for general fitting and standard finish specifications.

Wing Fittings

B267R THREE HOLE SINGLE CORNER CONNECTION (RIGHT HAND)

- Standard finishes: ZN, GRN
- Wt./C 54 Lbs. (24.5 kg)

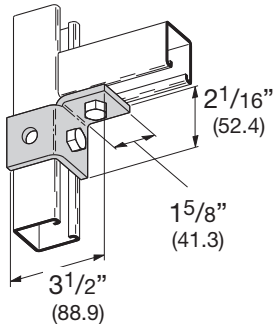

B267L THREE HOLE SINGLE CORNER CONNECTION (LEFT HAND)

- Standard finishes: ZN, GRN
- Wt./C 54 Lbs. (24.5 kg)

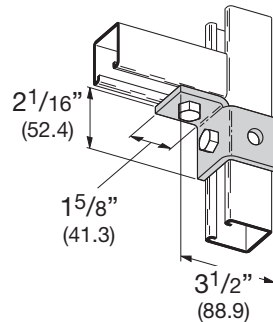

B270R FOUR HOLE SINGLE CORNER CONNECTION (RIGHT HAND)

- Standard finishes: ZN, GRN
- Wt./C 77 Lbs. (34.9 kg)

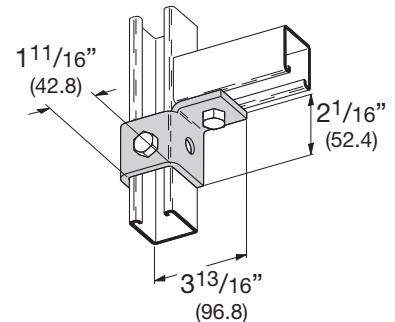

B270L FOUR HOLE SINGLE CORNER CONNECTION (LEFT HAND)

- Standard finishes: ZN, GRN
- Wt./C 77 Lbs. (34.9 kg)

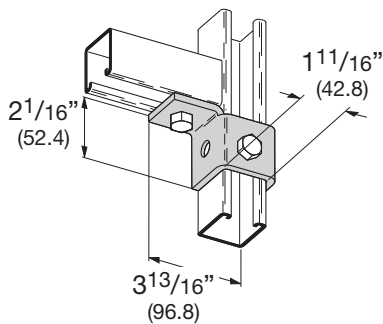

B268R FIVE HOLE SINGLE CORNER CONNECTION (RIGHT HAND)

- Standard finishes: ZN, GRN
- Wt./C 100 Lbs. (45.3 kg)

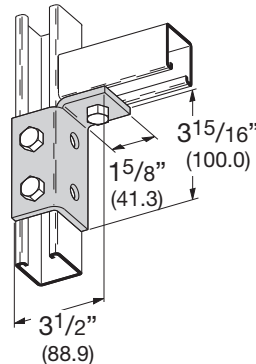

B268L FIVE HOLE SINGLE CORNER CONNECTION (LEFT HAND)

- Standard finishes: ZN, GRN
- Wt./C 100 Lbs. (45.3 kg)

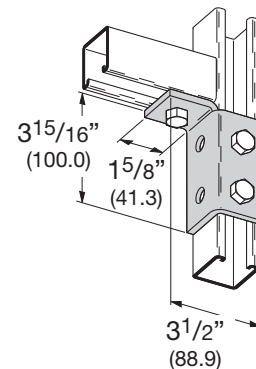

B269R SIX HOLE SINGLE CORNER CONNECTION (RIGHT HAND)

- Standard finishes: ZN, GRN
- Wt./C 120 Lbs. (54.4 kg)

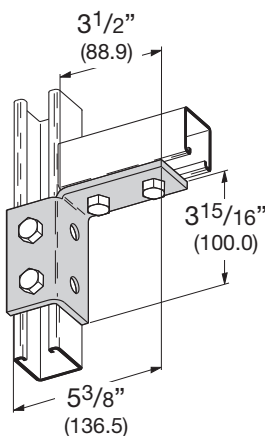

B269L SIX HOLE SINGLE CORNER CONNECTION (LEFT HAND)

- Standard finishes: ZN, GRN
- Wt./C 120 Lbs. (54.4 kg)

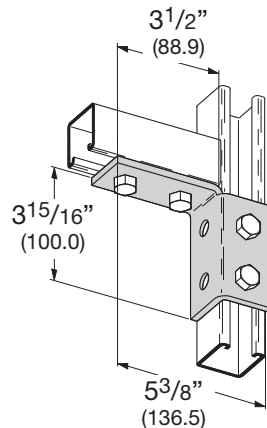

B119 FOUR HOLE DOUBLE CORNER CONNECTION

- Standard finishes: ZN, GRN
- Wt./C 71 Lbs. (32.2 kg)

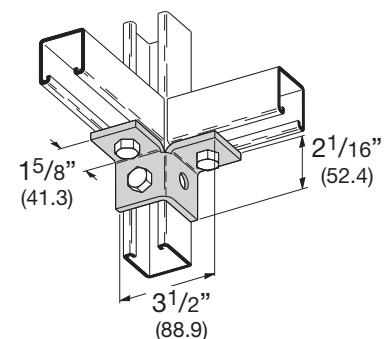

Reference page 72 for general fitting and standard finish specifications.

B120 SIX HOLE DOUBLE CORNER CONNECTION

- Standard finishes: ZN, GRN
- Wt./C 110 Lbs. (49.9 kg)

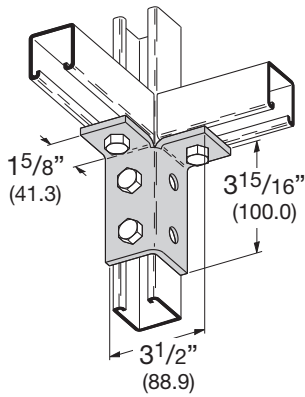

B121 EIGHT HOLE DOUBLE CORNER CONNECTION

- Standard finishes: ZN, GRN
- Wt./C 152 Lbs. (68.9 kg)

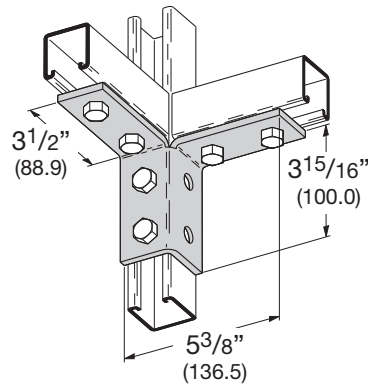

B271 FIVE HOLE DOUBLE WING CONNECTION

- Standard finishes: ZN, GRN
- Wt./C 95 Lbs. (43.1 kg)

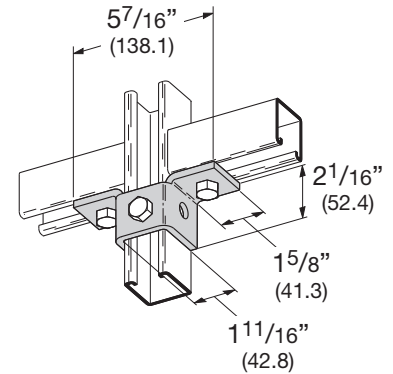

B272 EIGHT HOLE DOUBLE WING CONNECTION

- Standard finishes: ZN, GRN
- Wt./C 156 Lbs. (70.7 kg)

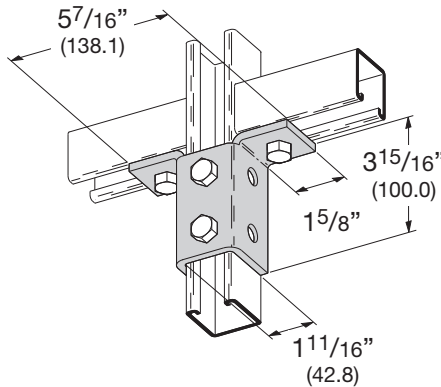

B273 TEN HOLE DOUBLE WING CONNECTION

- Standard finishes: ZN, GRN
- Wt./C 185 Lbs. (83.9 kg)

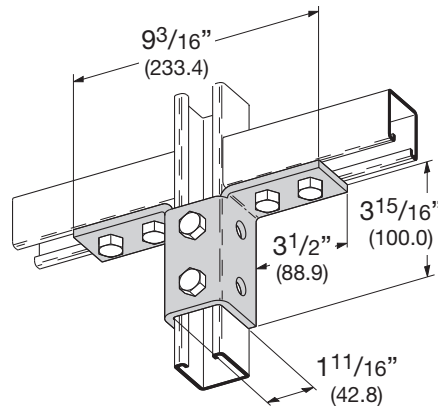

B122 SIX HOLE TRIPLE WING CONNECTION

- Standard finishes: ZN, GRN
- Wt./C 110 Lbs. (49.9 kg)

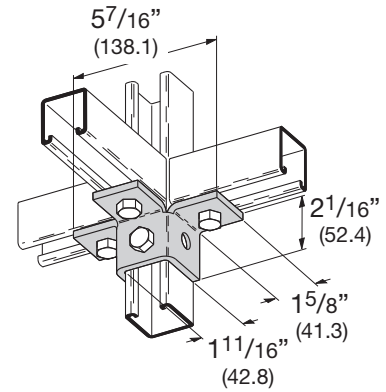

B123 TWELVE HOLE TRIPLE WING CONNECTION

- Standard finishes: ZN, GRN
- Wt./C 234 Lbs. (106.1 kg)

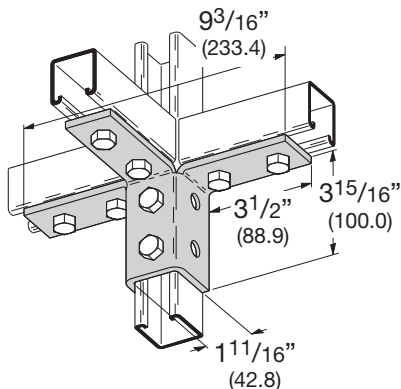

B124 NINE HOLE TRIPLE WING CONNECTION

- Standard finishes: ZN, GRN
- Wt./C 177 Lbs. (80.3 kg)

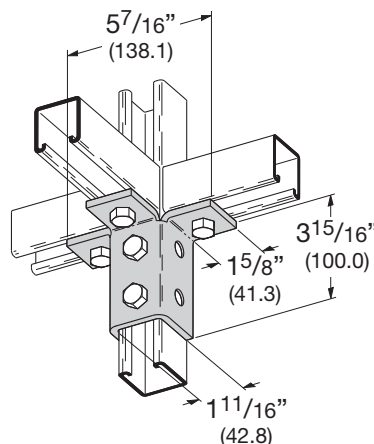

B276 FOURTEEN HOLE DOUBLE CORNER GUSSETED CONNECTION

- Standard finishes: ZN, GRN
- Wt./C 196 Lbs. (88.9 kg)

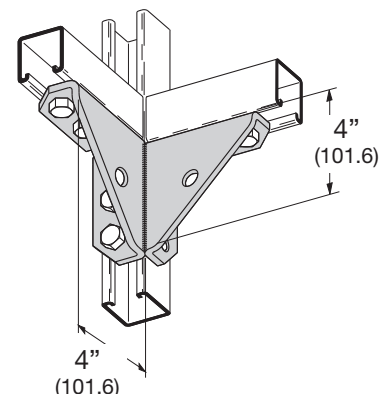

Reference page 72 for general fitting and standard finish specifications.

Wing Fittings

B274R EIGHT HOLE SINGLE CORNER GUSSETED CONNECTION (RIGHT HAND)

- Standard finishes: ZN, GRN
- Wt./C 176 Lbs. (79.8 kg)

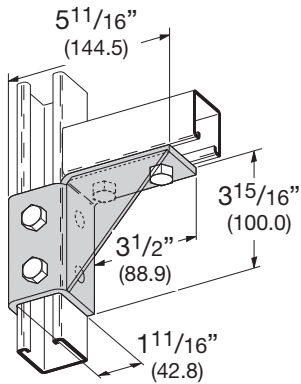

B274L EIGHT HOLE SINGLE CORNER GUSSETED CONNECTION (LEFT HAND)

- Standard finishes: ZN, GRN
- Wt./C 176 Lbs. (79.8 kg)

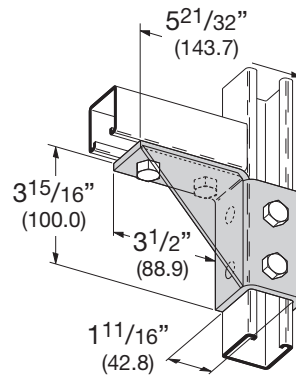

B495 TEN HOLE DOUBLE WING GUSSETED CONNECTION

- Standard finishes: ZN, GRN
- Wt./C 240 Lbs. (108.8 kg)

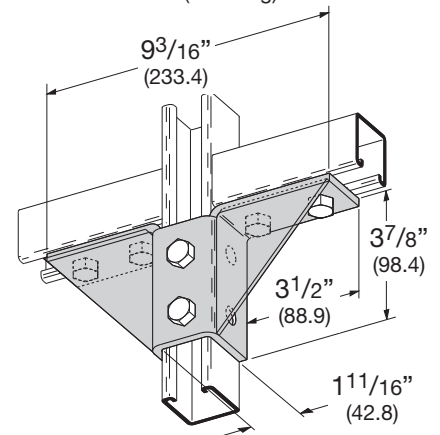

B277 TWELVE HOLE TRIPLE WING GUSSETED CONNECTION

- Standard finishes: ZN, GRN
- Wt./C 285 Lbs. (129.3 kg)

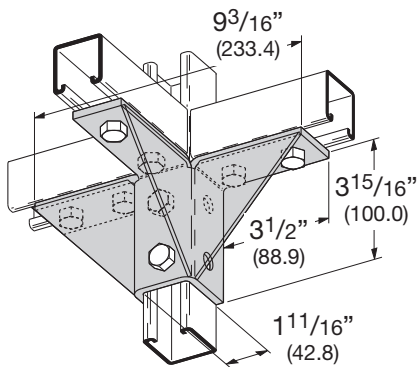

B362 EIGHT HOLE DOUBLE CORNER GUSSETED CONNECTION

- Standard finishes: ZN, GRN
- Wt./C 226 Lbs. (102.5 kg)

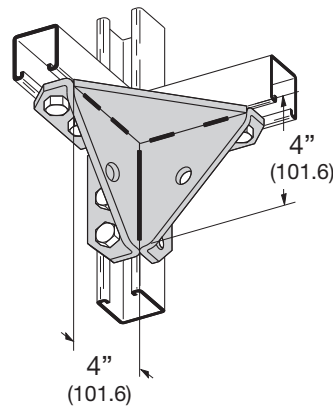

B571 EIGHT HOLE WING CONNECTION

- Standard finishes: ZN, GRN
- Wt./C 201 Lbs. (91.2 kg)

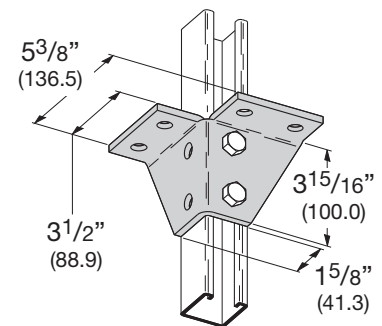

B346L EIGHT HOLE DOUBLE CORNER GUSSETED CONNECTION (LEFT HAND)

- Standard finishes: ZN, GRN
- Wt./C 242 Lbs. (109.8 kg)

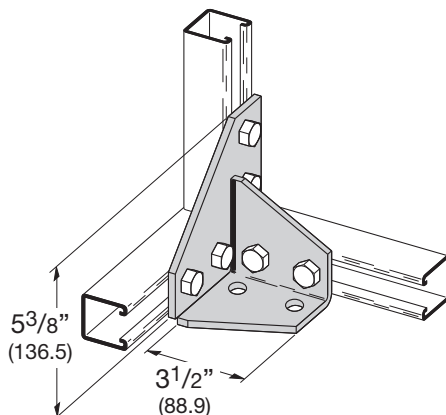

B346R EIGHT HOLE DOUBLE CORNER GUSSETED CONNECTION (RIGHT HAND)

- Standard finishes: ZN, GRN
- Wt./C 242 Lbs. (109.8 kg)

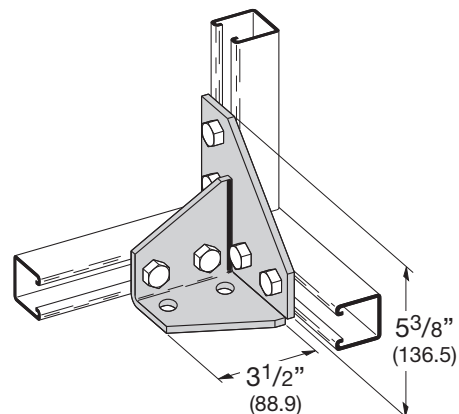

Reference page 72 for general fitting and standard finish specifications.

B279 POST BASE FOR B22

- Standard finishes: ZN, GRN
- Wt./C 314 Lbs. (142.4 kg)

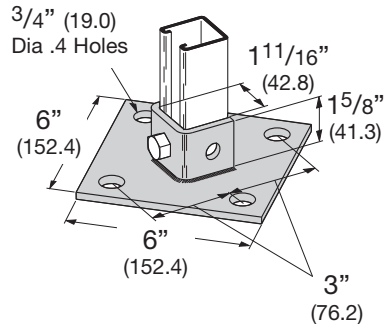

B279SQ POST BASE FOR B22

- Standard finishes: ZN, GRN
- Wt./C 314 Lbs. (142.4 kg)

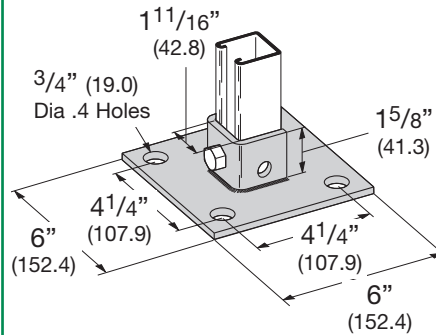

B279FL POST BASE FOR B22

- Standard finishes: ZN, GRN
- Wt./C 230 Lbs. (104.3 kg)

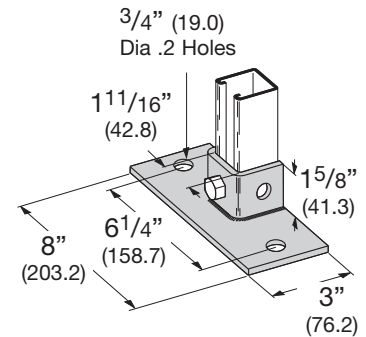

B280 POST BASE FOR B22

- Standard finishes: ZN, GRN, HDG, SS4, AL
- Wt./C 392 Lbs. (177.8 kg)

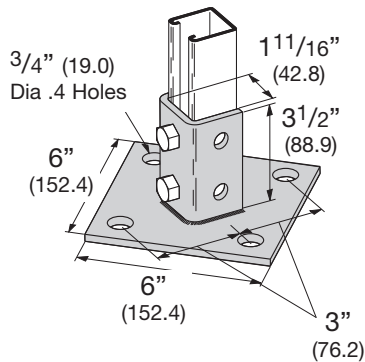

B280SQ POST BASE FOR B22

- Standard finishes: ZN, GRN, HDG, SS4, AL
- Wt./C 392 Lbs. (177.8 kg)

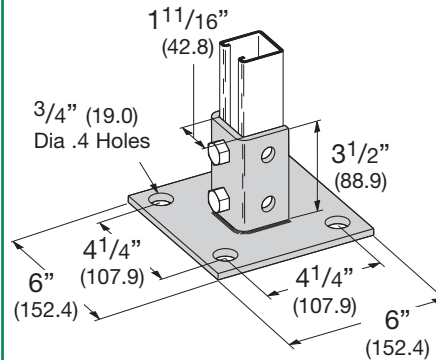

B280FL POST BASE FOR B22

- Standard finishes: ZN, GRN, HDG, SS4
- Wt./C 312 Lbs. (141.5 kg)

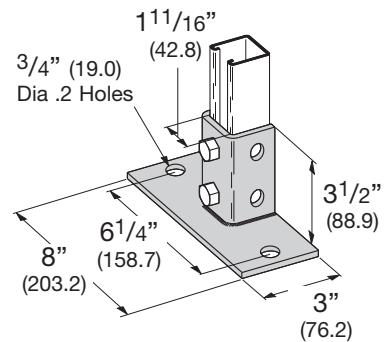

B281A POST BASE FOR B22A, B, C, ETC.

- Standard finishes: ZN, GRN
- Wt./C 330 Lbs. (149.7 kg)

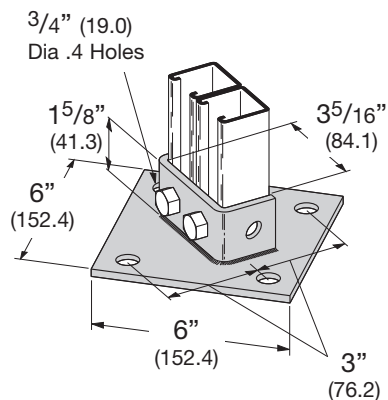

B281ASQ POST BASE FOR B22A, B, C, ETC.

- Standard finishes: ZN, GRN
- Wt./C 330 Lbs. (149.7 kg)

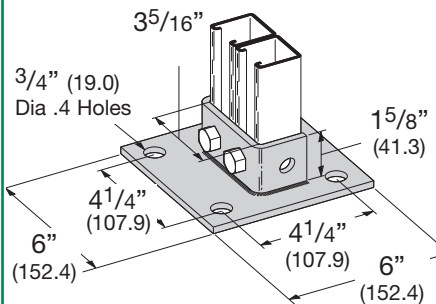

B281AFL POST BASE FOR B22A, B, C, ETC.

- Standard finishes: ZN, GRN
- Wt./C 250 Lbs. (113.4 kg)

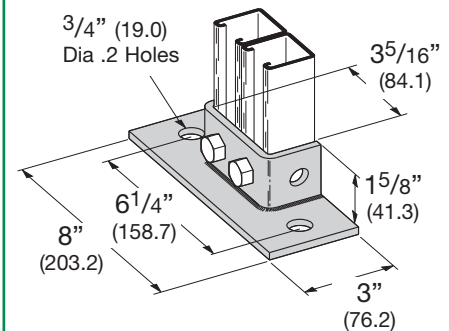

Reference page 72 for general fitting and standard finish specifications.

Post Bases

B281 POST BASE FOR B22A, B, C, ETC.

- Standard finishes: ZN, GRN, HDG
- Wt./C 400 Lbs. (181.4 kg)

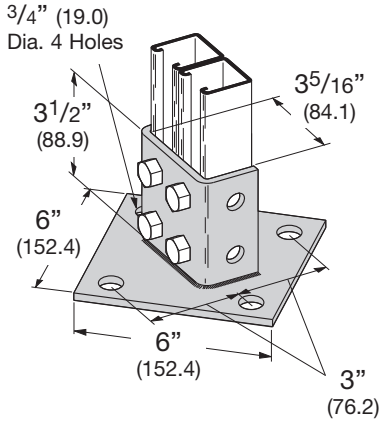

B281SQ POST BASE FOR B22A, B, C, ETC.

- Standard finishes: ZN, GRN, HDG, SS4
- Wt./C 400 Lbs. (181.4 kg)

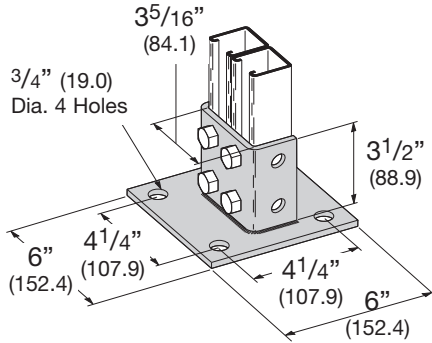

B281FL POST BASE FOR B22A, B, C, ETC.

- Standard finishes: ZN, GRN
- Wt./C 320 Lbs. (145.1 kg)

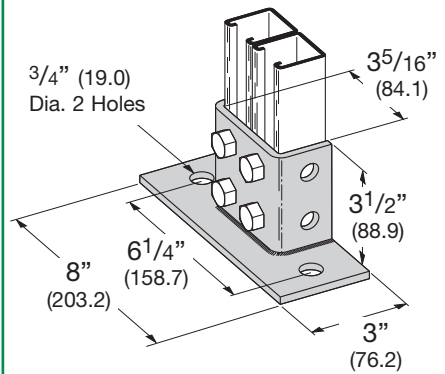

B281M POST BASE FOR B22-2PL

- Standard finishes: ZN, GRN
- Wt./C 470 Lbs. (213.2 kg)

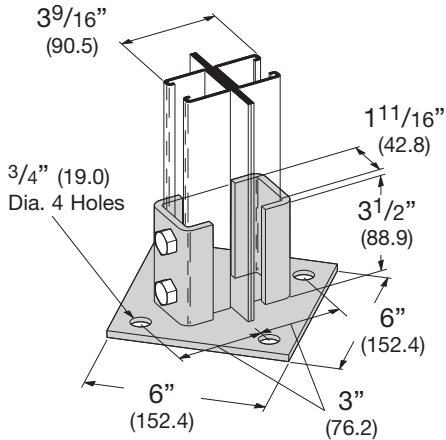

B281MSQ POST BASE FOR B22-2PL

- Standard finishes: ZN, GRN
- Wt./C 470 Lbs. (213.2 kg)

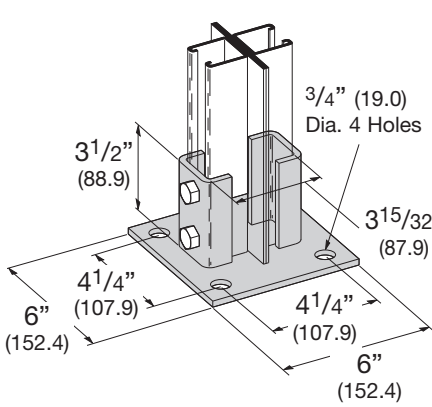

B570 POST BASE FOR FOUR CHANNEL COMBINATIONS

- Standard finishes: ZN, GRN
- Wt./C 397 Lbs. (180.1 kg)

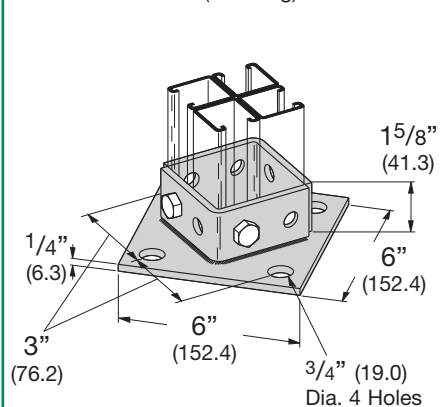

B570A POST BASE FOR FOUR CHANNEL COMBINATIONS

- Standard finishes: ZN, GRN
- Wt./C 550 Lbs. (249.5 kg)

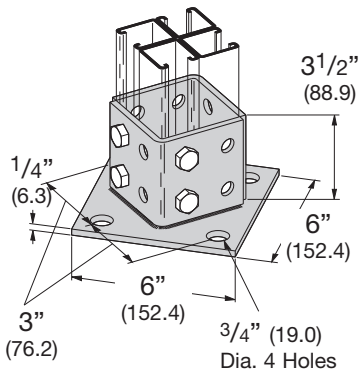

B278 POST BASE FOR B22

- Standard finishes: ZN, GRN
- Wt./C 288 Lbs. (130.6 kg)

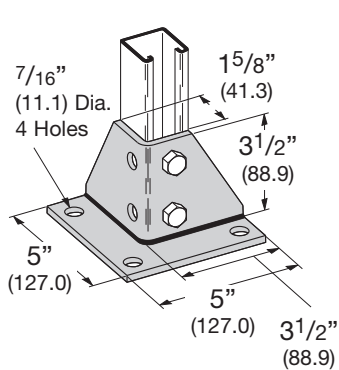

B585 POST BASE FOR B22A

- Standard finishes: ZN, GRN
- Wt./C 97 Lbs. (44.0 kg)

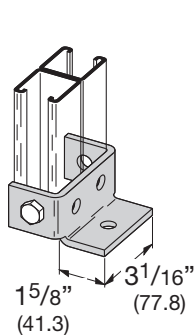

B300 POST BASE

- Material: Malleable Iron
- Standard finishes: ZN, GRN
- Wt./C 259 Lbs. (117.5 kg)

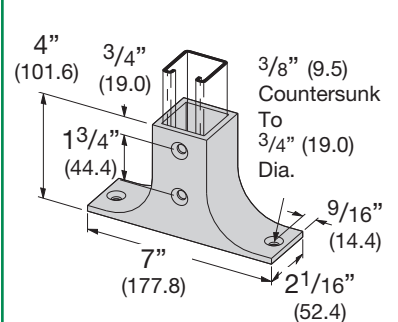

Strut Fittings

Reference page 72 for general fitting and standard finish specifications.

B187 BRACKET

- Uniform Loading 1450 Lbs. (6.45 kN)
- Safety Factor of 2.5
- Hole Spacing on Bracket Top $5\frac{5}{16}$ " (150.8) Center to Center
- Standard finishes: ZN, GRN
- Wt./C 193 Lbs. (87.5 kg)

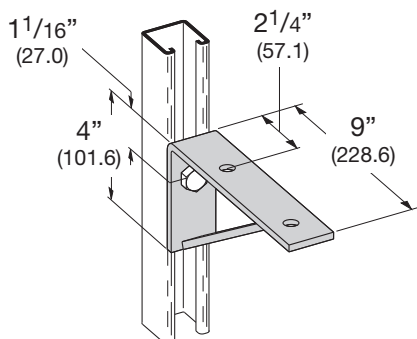

B188 BRACKET

- Uniform Loading 1080 Lbs. (4.80 kN)
- Safety Factor of 2.5
- Hole Spacing on Bracket Top $8\frac{15}{16}$ " (227.0) Center to Center
- Standard finishes: ZN, GRN
- Wt./C 241 Lbs. (109.3 kg)

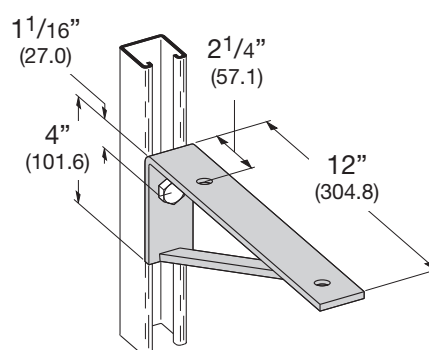

B189 BRACKET

- Uniform Loading 870 Lbs. (3.87 kN)
- Safety Factor of 2.5
- Hole Spacing on Bracket Top $11\frac{15}{16}$ " (303.2) Center to Center
- Standard finishes: ZN, GRN
- Wt./C 308 Lbs. (139.7 kg)

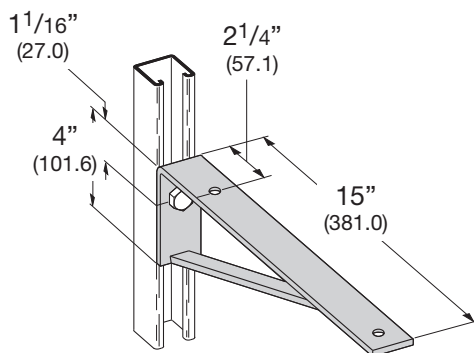

B541 BRACKET

- Uniform Loading 1240 Lbs. (5.51 kN)
- Safety Factor of 2.5
- Hole Spacing on Bracket Top $7\frac{7}{16}$ " (188.9) Center to Center
- Standard finishes: ZN, GRN
- Wt./C 201 Lbs. (91.2 kg)

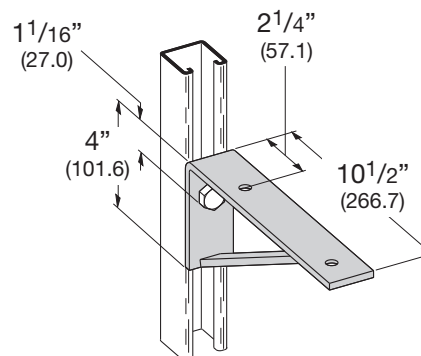

B190 12" (304.8) BRACKET

- Uniform Loading 900 Lbs. (4.00 kN)
- Safety Factor of 2.5
- Standard finishes: ZN, GRN
- Wt./C 260 Lbs. (117.9 kg)

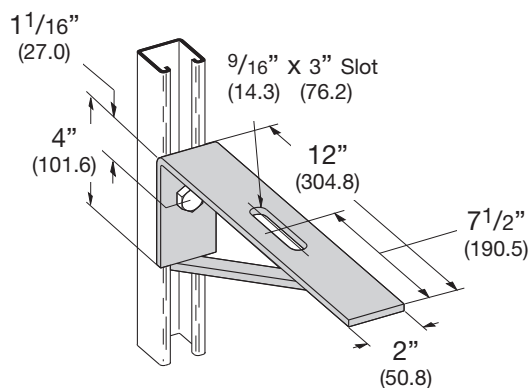

B191-18 18" (457.2) BRACKET

- Uniform Loading 600 Lbs. (2.67 kN)
- Safety Factor of 2.5
- Standard finishes: ZN, GRN
- Wt./C 377 Lbs. (171.0 kg)

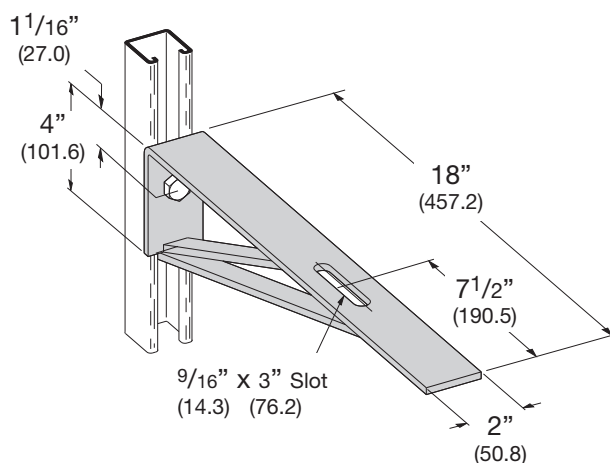

Reference page 72 for general fitting and standard finish specifications.

Brackets

B191-24 24" (609.6) BRACKET

- Uniform Loading 450 Lbs. (2.00 kN)
- Safety Factor of 2.5
- Standard finishes: ZN, GRN
- Wt./C 377 Lbs. (171.0 kg)

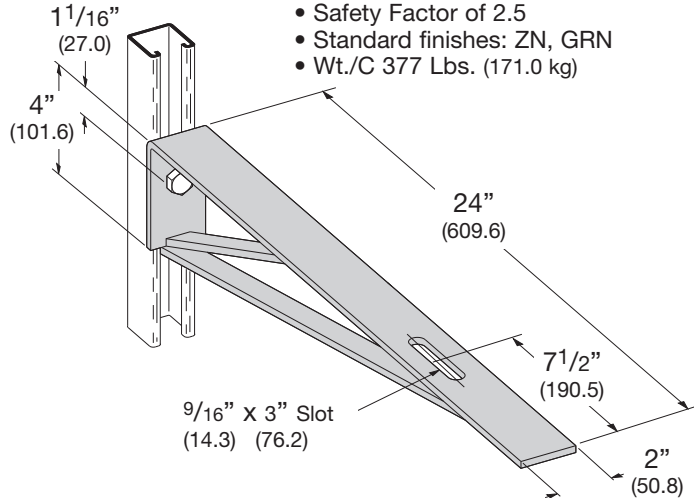

B192 24" (609.6) BRACKET

- Uniform Loading 820 Lbs. (3.65 kN)
- Safety Factor of 2.5
- Standard finishes: ZN, GRN
- Wt./C 576 Lbs. (261.3 kg)

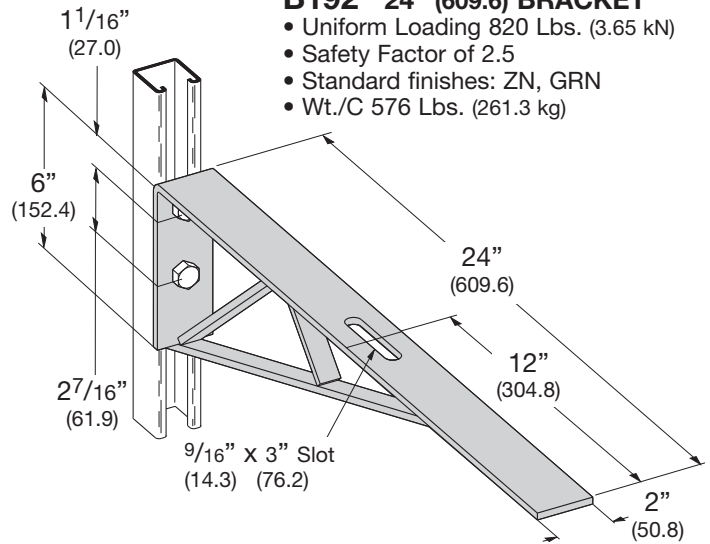

B290 16 1/2" (419.1) BRACKET

- Uniform Loading 1200 Lbs. (5.34 kN)
- Safety Factor of 2.5
- Standard finishes: ZN, GRN
- Wt./C 405 Lbs. (183.7 kg)

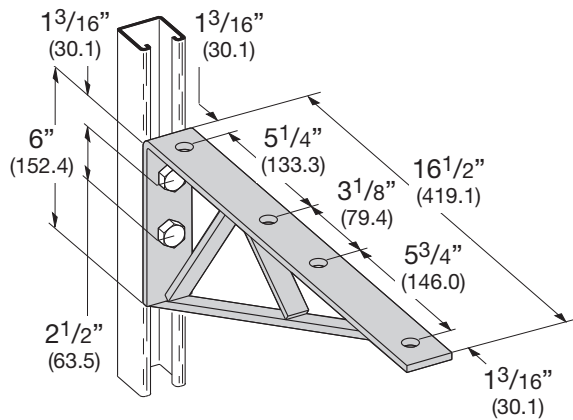

B289-12 12 1/2" (317.5) BRACKET

- Uniform Loading 1040 Lbs. (4.63 kN)
- Safety Factor of 2.5
- Standard finishes: ZN, GRN
- Wt./C 285 Lbs. (129.3 kg)

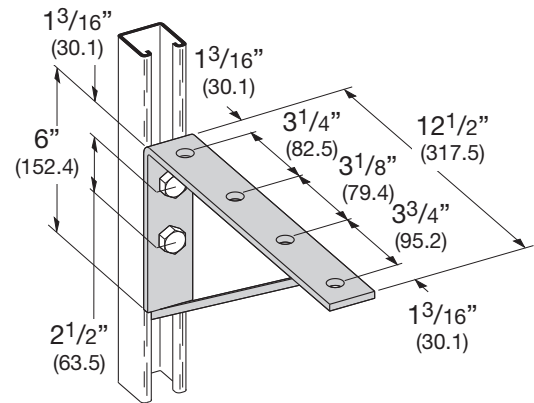

B289-14 14 1/2" (368.3) BRACKET

- Uniform Loading 900 Lbs. (4.00 kN)
- Safety Factor of 2.5
- Standard finishes: ZN, GRN
- Wt./C 295 Lbs. (133.8 kg)

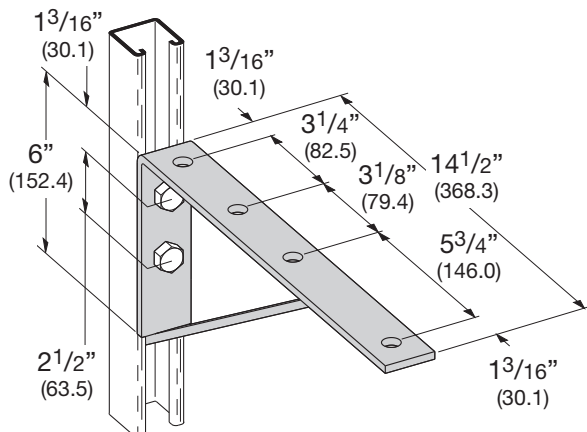

B291 18 1/2" (469.9) BRACKET

- Uniform Loading 1070 Lbs. (4.76 kN)
- Safety Factor of 2.5
- Standard finishes: ZN, GRN
- Wt./C 468 Lbs. (212.3 kg)

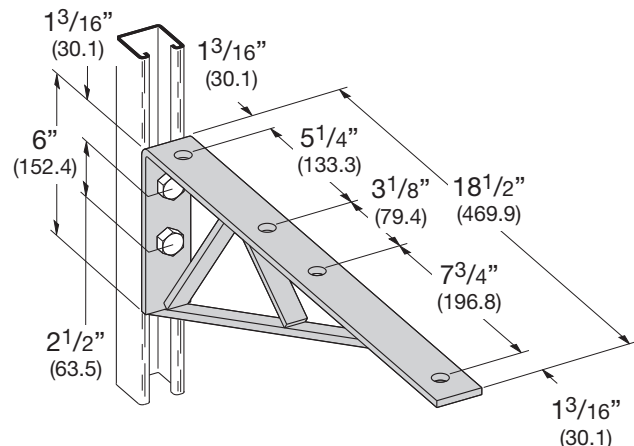

Reference page 72 for general fitting and standard finish specifications.

B292 20¹/₂" (520.7) BRACKET

- Uniform Loading 600 Lbs. (2.67 kN)
- Safety Factor of 2.5
- Standard finishes: ZN, GRN, HDG, SS4
- Wt./C 490 Lbs. (222.2 kg)

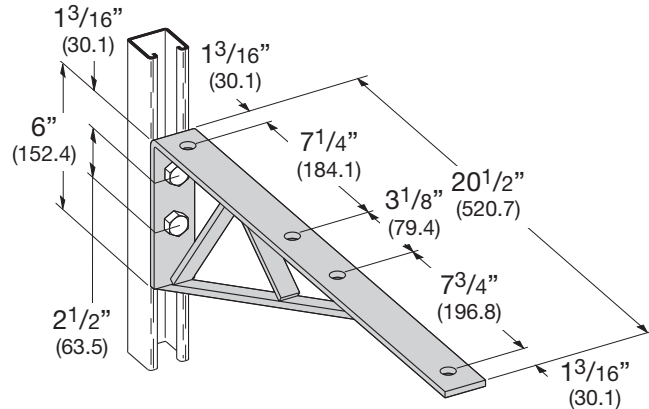

B297 DOUBLE CHANNEL BRACKET

- Safety Factor of 2.5
- Standard finishes: ZN, GRN, HDG

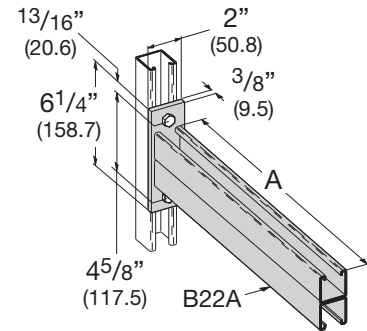

Part No.	A	Uniform Load		Wt./C	
		Lbs.	kN	Lbs.	kg
B297-12	12" (304.8)	1660	(7.37)	485	(220.0)
B297-18	18" (457.2)	1100	(4.88)	668	(303.0)
B297-24	24" (609.6)	835	(3.71)	857	(388.7)
B297-30	30" (762.0)	665	(2.95)	1040	(471.7)
B297-36	36" (914.4)	550	(2.44)	1240	(562.4)
B297-42	42" (1066.8)	465	(2.06)	1440	(653.2)

B409 SINGLE CHANNEL BRACKET

- Safety Factor of 2.5
- Standard finishes: ZN, GRN, SS4

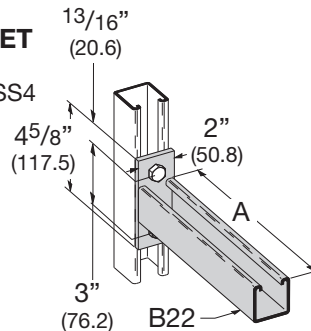

Part No.	A	Uniform Load		Wt./C	
		Lbs.	kN	Lbs.	kg
B409-6	6" (152.4)	1920	(8.54)	152	(68.9)
B409-9	9" (228.6)	1280	(5.69)	195	(88.4)
B409-12	12" (304.8)	960	(4.27)	232	(105.2)
B409-14	14" (355.6)	800	(3.56)	274	(124.3)
B409-16	16" (406.4)	730	(3.25)	314	(142.4)
B409-18	18" (457.2)	640	(2.84)	347	(157.4)
B409-24	24" (609.6)	480	(2.13)	450	(204.1)

B494 BRACED SINGLE BRACKET

- Safety Factor of 2.5
- Standard finishes: ZN, GRN

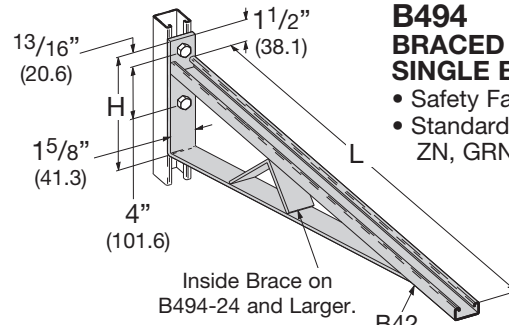

Part No.	L	H	Uniform Load		Wt. /C	
			Lbs.	kN	Lbs.	kg
B494-12	12" (304.8)	8 ³ / ₄ " (222.2)	1580	(7.02)	364	(165.1)
B494-18	18" (475.2)	8 ³ / ₄ " (222.2)	1000	(4.45)	479	(217.3)
B494-24	24" (609.6)	8 ³ / ₄ " (222.2)	996	(4.43)	716	(324.8)
B494-30	30" (762.0)	11 ¹ / ₄ " (285.7)	924	(4.11)	927	(420.5)
B494-36	36" (914.4)	11 ¹ / ₄ " (285.7)	864	(3.84)	1095	(496.7)
B494-42	42" (1066.8)	16" (406.4)	580	(2.58)	1400	(635.0)
B494-48	48" (1219.2)	16" (406.4)	500	(2.22)	1510	(684.9)

B174SH-B186SH L&R SLOTTED BRACKET

- Safety Factor of 2.5
- Specify L for left or R for right bracing
- Material: ASTM A1011 33,000 PSI min. yield
- Standard finishes: ZN, GRN

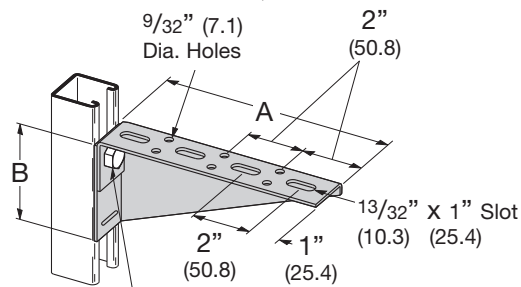

Mounting Hole
7/16" (11.1) Dia.

Right bracket shown, left bracket
gusset on opposite side.

Part No.	A	B	Uniform Load		Wt./C	
			Lbs.	kN	Lbs.	kg
B174SH	24" (609.6)	6 ⁷ / ₁₆ " (163.5)	225	(1.00)	370	(167.8)
B175SH	26" (660.4)	6 ¹⁵ / ₁₆ " (176.2)	225	(1.00)	425	(192.8)
B176SH	28" (711.2)	7 ⁷ / ₁₆ " (188.9)	225	(1.00)	480	(217.7)
B177SH	30" (762.0)	7 ¹⁵ / ₁₆ " (201.6)	225	(1.00)	520	(235.9)
B178SH	12" (304.8)	3 ⁷ / ₁₆ " (87.3)	350	(1.55)	143	(64.8)
B179SH	14" (355.6)	3 ¹⁵ / ₁₆ " (100.0)	350	(1.55)	162	(73.5)
B180SH	16" (406.4)	4 ⁷ / ₁₆ " (112.7)	250	(1.11)	204	(92.5)
B181SH	18" (457.2)	4 ¹⁵ / ₁₆ " (125.4)	250	(1.11)	232	(105.2)
B182SH	20" (508.0)	5 ⁷ / ₁₆ " (138.1)	250	(1.11)	275	(124.7)
B183SH	22" (558.8)	5 ¹⁵ / ₁₆ " (150.8)	250	(1.11)	317	(143.8)
B184SH	6" (152.4)	1 ¹⁵ / ₁₆ " (49.2)	225	(1.00)	58	(26.3)
B185SH	8" (203.2)	2 ⁷ / ₁₆ " (61.9)	225	(1.00)	82	(37.2)
B186SH	10" (254.0)	2 ¹⁵ / ₁₆ " (74.6)	325	(1.44)	103	(46.7)

Reference page 72 for general fitting and standard finish specifications.

Brackets

B196 CHANNEL CLEVIS BRACKET

- Safety Factor of 2.5
- Standard finishes: ZN, GRN

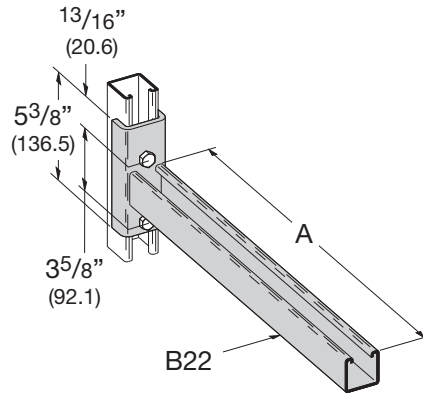

Part No.	A	(A)	Uniform Load		Wt./C	
			Lbs.	kN	Lbs.	kg
B196-18	18"	(457.2)	600	(2.67)	430	(195.0)
B196-24	24"	(609.6)	450	(2.00)	510	(231.3)

B198A CHANNEL CLEVIS BRACKET

- Safety Factor of 2.5
- Standard finishes: ZN, GRN

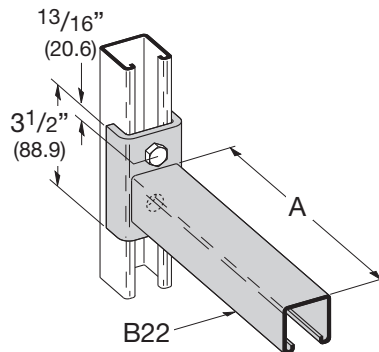

Part No.	A	(A)	Uniform Load		Wt./C	
			Lbs.	kN	Lbs.	kg
B198A-6	6"	(152.4)	1600	(7.12)	185	(83.9)
B198A-12	12"	(304.8)	800	(3.56)	284	(128.8)

B293A CHANNEL BRACKET

- Safety Factor of 2.5
- Standard finishes: ZN, GRN

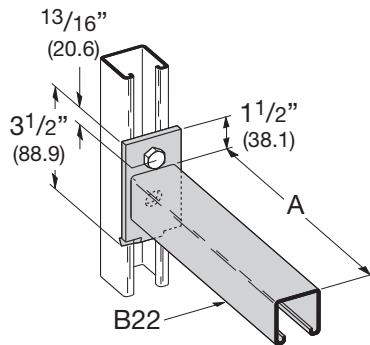

Part No.	A	(A)	Uniform Load		Wt./C	
			Lbs.	kN	Lbs.	kg
B293A-6	6"	(152.4)	1200	(5.34)	144	(65.3)
B293A-12	12"	(304.8)	600	(2.67)	252	(114.3)
B293A-18	18"	(457.2)	400	(1.78)	340	(154.2)
B293A-24	24"	(609.6)	300	(1.33)	412	(186.9)

B198 CHANNEL CLEVIS BRACKET

- Safety Factor of 2.5
- Standard finishes: ZN, GRN

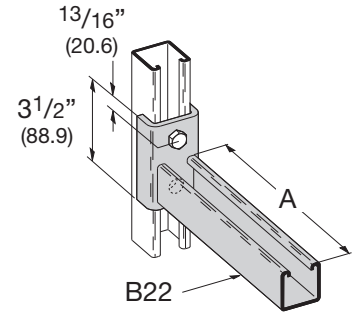

Part No.	A	(A)	Uniform Load		Wt./C	
			Lbs.	kN	Lbs.	kg
B198-6	6"	(152.4)	1600	(7.12)	185	(83.9)
B198-12	12"	(304.8)	800	(3.56)	284	(128.8)

B293 CHANNEL BRACKET

- Safety Factor of 2.5
- Standard finishes: ZN, GRN

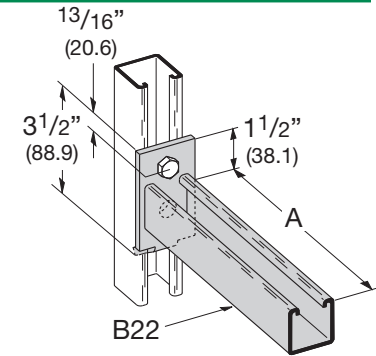

Part No.	A	(A)	Uniform Load		Wt./C	
			Lbs.	kN	Lbs.	kg
B293-6	6"	(152.4)	1200	(5.34)	144	(65.3)
B293-12	12"	(304.8)	600	(2.67)	252	(114.3)
B293-18	18"	(457.2)	400	(1.78)	340	(154.2)
B293-24	24"	(609.6)	300	(1.33)	412	(186.9)

B194 BRACKET FOR B22 & B24

- Safety Factor of 2.5
- 6300 In.-Lbs (712 N•m) applies to fitting only, not to strength of strut arm
- Refer to page 223 for strut loading data
- Standard finishes: ZN, GRN
- Wt./C 210 Lbs. (95.2 kg)

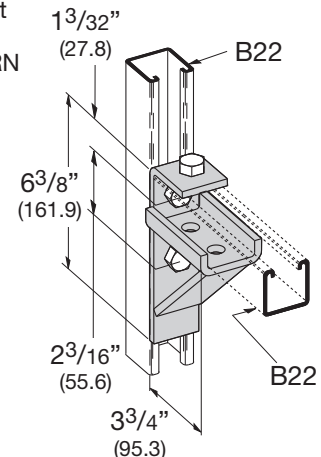

Reference page 72 for general fitting and standard finish specifications.

B370 BRACKET FOR B22A & B11

- Safety Factor of 2.5
- 13000 In.-Lbs (1469 N•m) applies to fitting only, not to strength of strut arm
- Refer to page 217 for strut loading data
- Standard finishes: ZN, GRN
- Wt./C 266 Lbs. (120.6 kg)

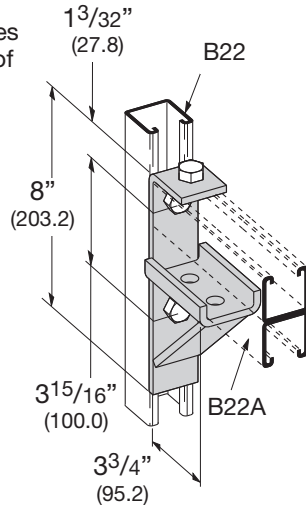

B195 BRACKET FOR B42

- Safety Factor of 2.5
- 2500 In.-Lbs (282 N•m) applies to fitting only, not to strength of strut arm
- Refer to page 217 for strut loading data
- Standard finishes: ZN, GRN
- Wt./C 174 Lbs. (78.9 kg)

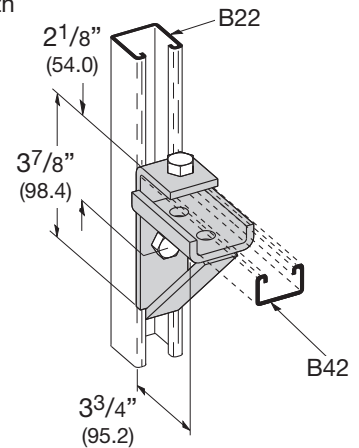

B440 BRACKET FOR B52 & B54

- Safety Factor of 2.5
- 2000 In.-Lbs (226 N•m) applies to fitting only, not to strength of strut arm
- Refer to page 217 for strut loading data
- Standard finishes: ZN, GRN
- Wt./C 177 Lbs. (80.3 kg)

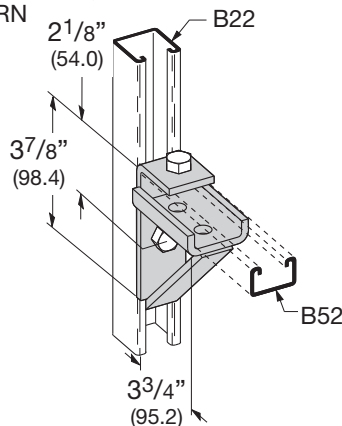

B449-4, 8 & 12 CABLE SADDLE BRACKET

- Safety Factor of 2.5
- Material: 11 Gauge (3.0) ASTM A1011 HSLAS Gr. 50
- Standard finishes: ZN, GRN

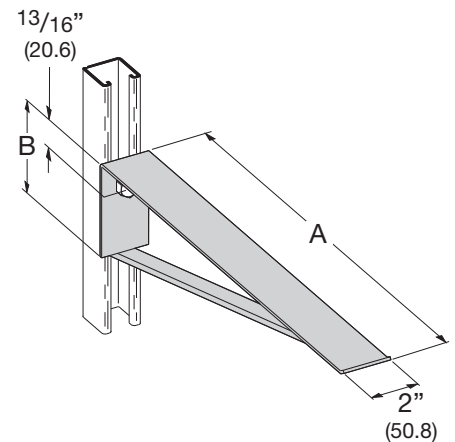

Part No.	A	B	Uniform Load		Wt./C	
			Lbs.	kN	Lbs.	kg
B449-4	4 1/2" (114.3)	2 3/8" (60.3)	2400	(10.67)	74	(33.5)
B449-8	8 1/2" (215.9)	2 3/8" (60.3)	1270	(5.65)	124	(56.2)
B449-12	12 1/2" (317.5)	4" (101.6)	860	(3.82)	184	(83.4)

B449-18 18" (457.2) CABLE SADDLE BRACKET

- Safety Factor of 2.5
- Uniform Load 960 Lbs. (4.17 kN)
- Material: 11 Gauge (3.0) ASTM A1011 HSLAS Gr. 50
- Standard finishes: ZN, GRN
- Wt./C 312 Lbs. (141.5 kg)

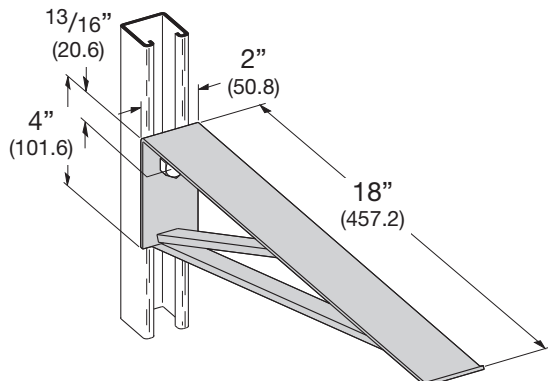

B293PL BRACKET PLATE ONLY

- Standard finishes: ZN, GRN
- Wt./C 46 Lbs. (20.8 kg)

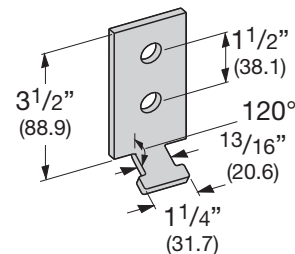

Reference page 72 for general fitting and standard finish specifications.

Brackets

B816

- Standard finishes: ZN, HDG

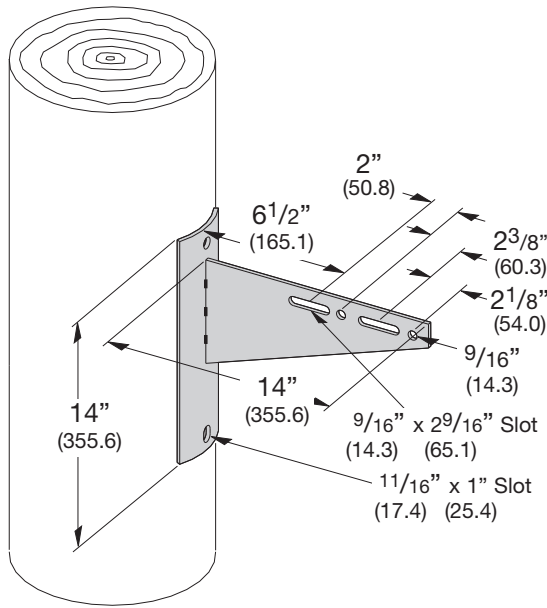

B852S-W-D

- Specify W = 8, 12, 16
- Specify D = 6, 8, 10, 12, 16, 18, 24
- 13/16" (20.6mm) x 1" (25.4mm) banding slots for steel band
- Standard finishes: ZN, HDG

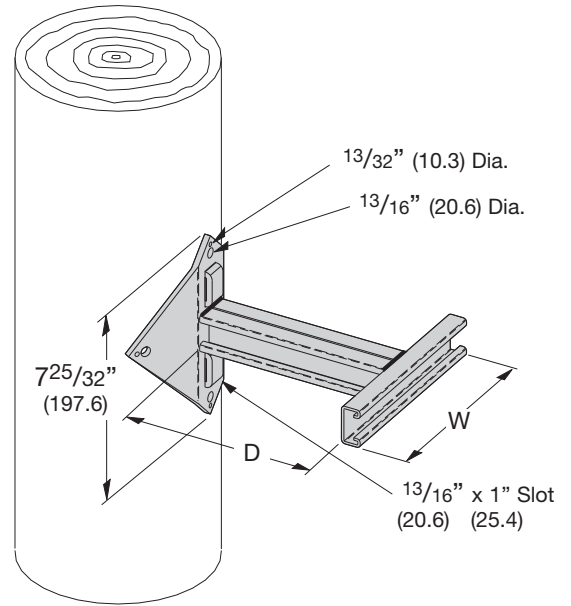

B802D-W

- Specify W = 8, 12, 16
- Standard finishes: ZN, HDG

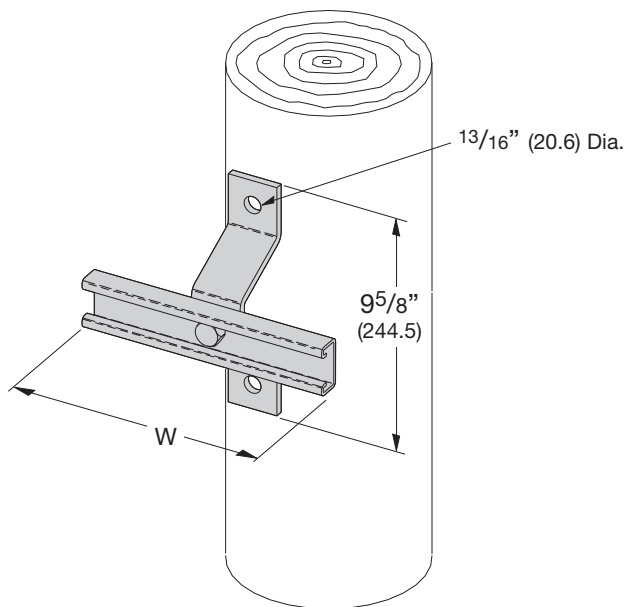

B810-W

- Specify W = 8, 12, 16
- 13/16" (20.6mm) x 1" (25.6mm) banding slots for steel band
- Standard finishes: ZN, HDG

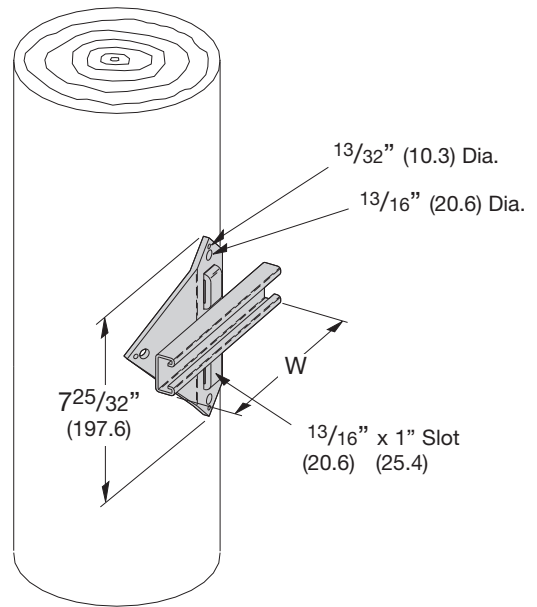

Reference page 72 for general fitting and standard finish specifications.

B811-W

- Can be attached directly to B809 & B812
- Specify W = 8, 12, 16
- Standard finishes: ZN, HDG

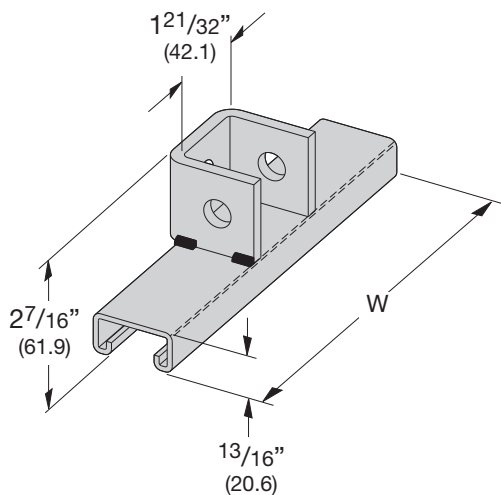

B812-*

- Specify D = 6, 8, 10, 12, 16, 18, 24
- 13/16" (20.6mm) x 1" (25.4mm) banding slots for steel band
- Standard finishes: ZN, HDG

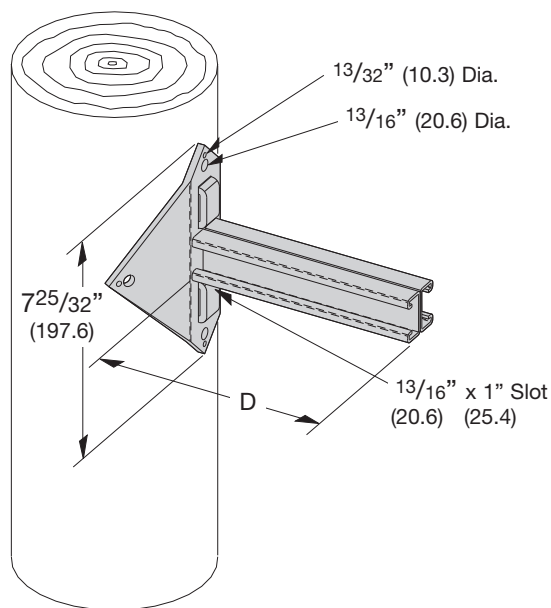

B809B-*

- Specify D = 6, 8, 10, 12, 16, 18, 24
- 13/16" (20.6mm) x 1" (25.4mm) banding slots for steel band
- Standard finishes: ZN, HDG

Part No.	D		H	
	In.	mm	In.	mm
B809B-6	6"	(152.4)	12 ³ / ₄ "	(323.9)
B809B-8	8"	(203.2)	14 ³ / ₄ "	(374.7)
B809B-10	10"	(254.0)	16 ³ / ₄ "	(425.5)
B809B-12	12"	(304.8)	18 ³ / ₄ "	(476.2)
B809B-16	16"	(406.4)	22 ³ / ₄ "	(577.8)
B809B-18	18"	(457.2)	24 ³ / ₄ "	(628.6)
B809B-24	24"	(609.6)	27 ³ / ₄ "	(704.8)

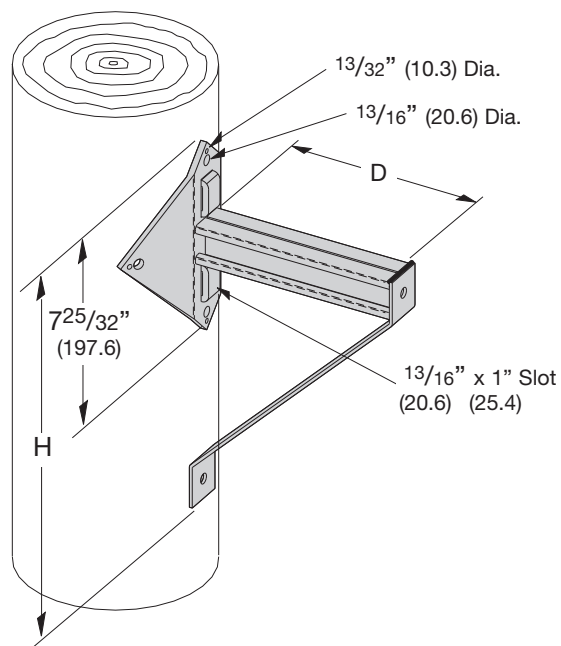

Reference page 72 for general fitting and standard finish specifications.

Miscellaneous Fittings

B214 R&L REEL RACK SUPPORT FOR 1 1/4" (32) PIPE

- Standard finishes: ZN, GRN
- Wt./C 200 Lbs. (90.7 kg)

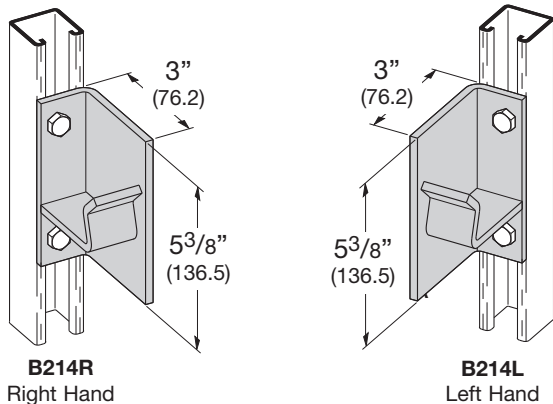

B514 R&L REEL RACK SUPPORT FOR 2" (50) PIPE

- Standard finishes: ZN, GRN
- Wt./C 246 Lbs. (111.6 kg)

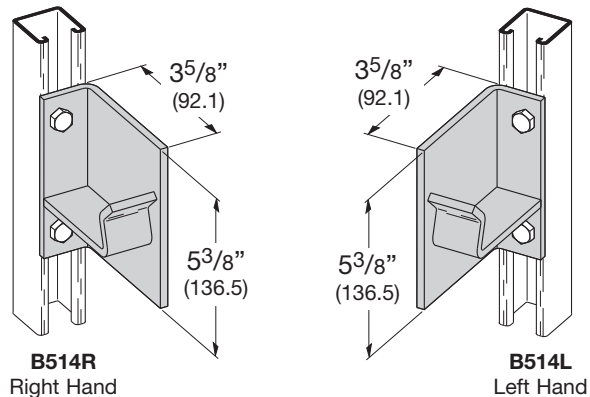

B475 DOUBLE REEL RACK SUPPORT ON SINGLE CHANNEL FOR 1 1/4" (32) PIPE

- Standard finishes: ZN, GRN
- Wt./C 326 Lbs. (147.9 kg)

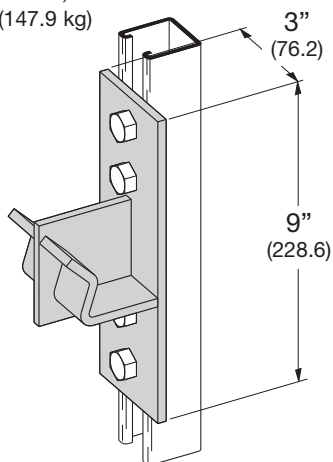

B473 DOUBLE REEL RACK SUPPORT ON SINGLE CHANNEL FOR 2" (50) PIPE

- Standard finishes: ZN, GRN
- Wt./C 351 Lbs. (159.2 kg)

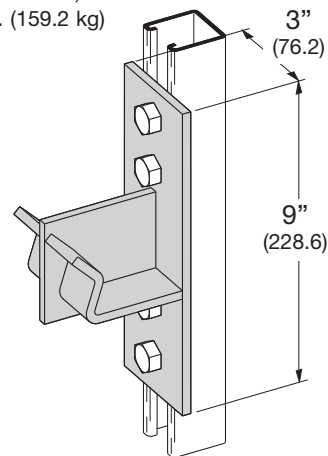

B474 DOUBLE REEL RACK CHANNEL FOR 1 1/4" (32) PIPE

- Standard finishes: ZN, GRN
- Wt./C 257 Lbs. (116.6 kg)

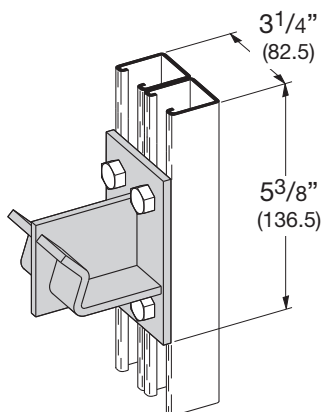

B472 DOUBLE REEL RACK SUPPORT ON DOUBLE CHANNEL FOR 2" (50) PIPE

- Standard finishes: ZN, GRN
- Wt./C 299 Lbs. (135.6 kg)

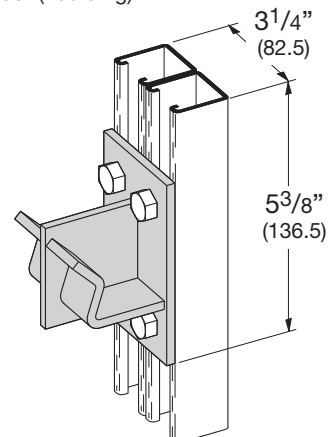

Reference page 72 for general fitting and standard finish specifications.

B438 PIPE SUPPORT BRACKET

- Standard finishes: ZN, GRN
- Material: ASTM A36
- Wt./C 132 Lbs. (59.9 kg)

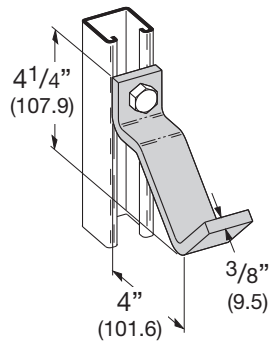

B439 PIPE SUPPORT BRACKET

- Standard finishes: ZN, GRN
- Wt./C 88 Lbs. (39.9 kg)

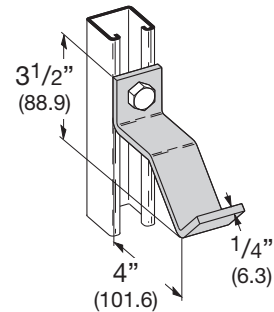

B411 SERIES LADDER RUNGS

- Standard finishes: ZN, GRN

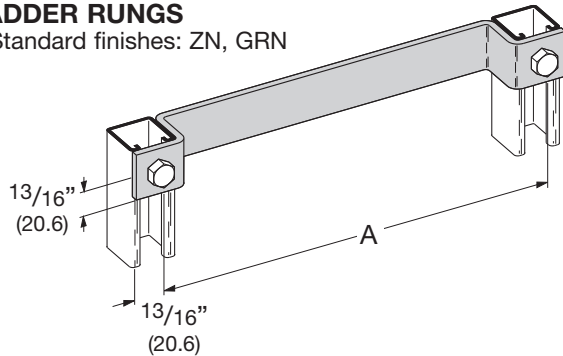

Part No.	A	(A)	Wt./C	
			Lbs.	kg
B411-12	12"	(304.8)	176	(79.8)
B411-15	15"	(381.0)	202	(91.6)
B411-18	18"	(457.2)	234	(106.1)

B381-B385 WALL LADDER BRACKETS

- Standard finishes: ZN, GRN

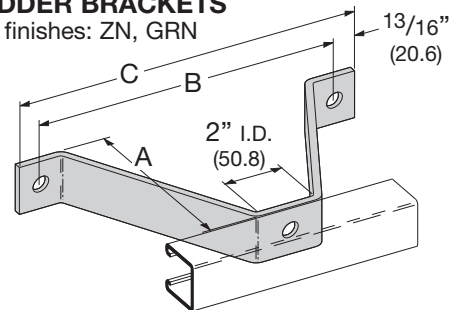

Part No.	A	(A)	B	(B)	C	(C)	Wt./C	
							Lbs.	kg
B381	2 ³ / ₈ "	(60.3)	6"	(152.4)	7 ⁵ / ₈ "	(193.7)	110	(49.9)
B382	4 ³ / ₈ "	(111.1)	8"	(203.2)	9 ⁵ / ₈ "	(244.5)	164	(74.4)
B383	6 ³ / ₈ "	(161.9)	10"	(254.0)	11 ⁵ / ₈ "	(295.3)	200	(90.7)
B384	8 ³ / ₈ "	(212.7)	12"	(304.8)	13 ⁵ / ₈ "	(346.1)	253	(114.7)
B385	10 ³ / ₈ "	(263.5)	14"	(355.6)	15 ⁵ / ₈ "	(396.9)	318	(144.2)

B587-1/2, 3/4 & 1 PIPE COUPLING FITTING

- Safety Factor of 2.5
- Standard finishes: ZN, GRN

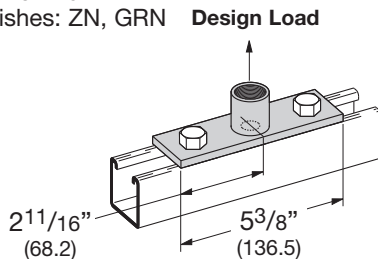

Part No.	For Pipe Size		Wt./C		Design Load	
	Lbs.	kg	Lbs.	kg	Lbs.	kN
B587-1/2	1/2"	(15)	77	(34.9)	1000	(4.45)
B587-3/4	3/4"	(20)	84	(38.1)	1400	(6.23)
B587-1	1"	(25)	105	(47.6)	1900	(8.45)

Reference page 72 for general fitting and standard finish specifications.

Miscellaneous Fittings

B349

TROLLEY BEAM SUPPORT

- Design Load 1200 Lbs. (5.34 kN)
- Safety Factor of 2.5
- Use $\frac{3}{8}$ " x 3" bolts in side hole to clamp strut together (not included)
- Standard finishes: ZN, GRN
- Wt./C 107 Lbs. (48.5 kg)

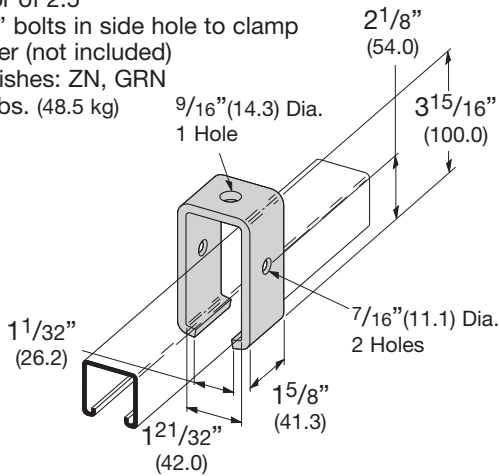

B350

TROLLEY BEAM JOINT SUPPORT

- Design Load 1200 Lbs. (5.34 kN)
- Use $\frac{3}{8}$ " x 3" bolts in side hole to clamp strut together (not included)
- Standard finishes: ZN, GRN
- Wt./C 233 Lbs. (105.7 kg)

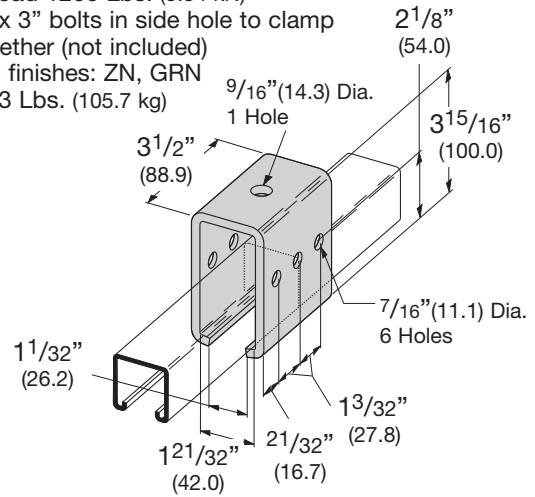

B614

COLUMN SUPPORT FOR B22

- Quick installation (one bolt to tighten)
- Design Load 800 Lbs. (3.56 kN) Slip with Safety Factor of 3
- Use with B22 and B24 Channel
- Sold in pairs
- Standard finish: ZN
- Wt./C 50 Lbs. (22.6 kg)

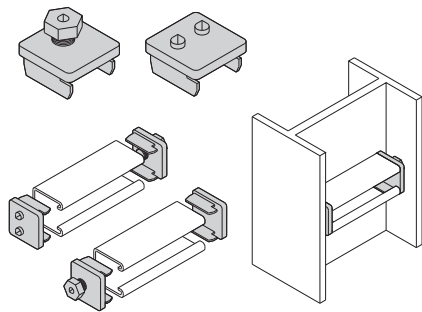

B613

COLUMN SUPPORT FOR B22

- Design Load 800 Lbs. (3.56 kN) Slip with Safety Factor of 3
- Use with B22 and B24 Channel
- Setscrews to be torqued to 19 ft./Lbs
- Sold in pairs
- Standard finishes: ZN, GRN, HDG
- Wt./C 100 Lbs. (45.3 kg)

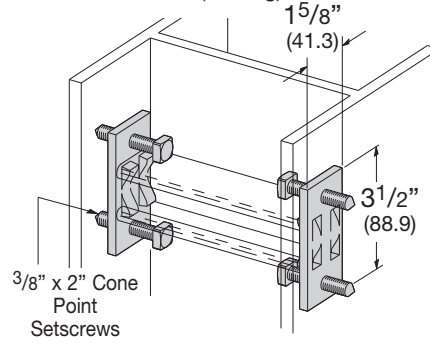

B613A

COLUMN SUPPORT FOR B52

- Design Load 800 Lbs. (3.56 kN) Slip with Safety Factor of 3
- Use with B52 and B54 Channel
- Setscrews to be torqued to 19 ft./Lbs
- Sold in pairs
- Standard finishes: ZN, GRN, HDG
- Wt./C 100 Lbs. (45.3 kg)

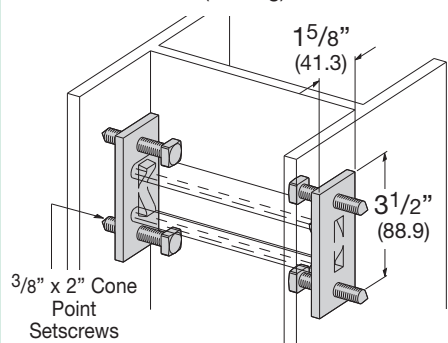

B560

45° STAIR SUPPORT

- Standard finishes: ZN, GRN
- Wt./C 220 Lbs. (99.8 kg)

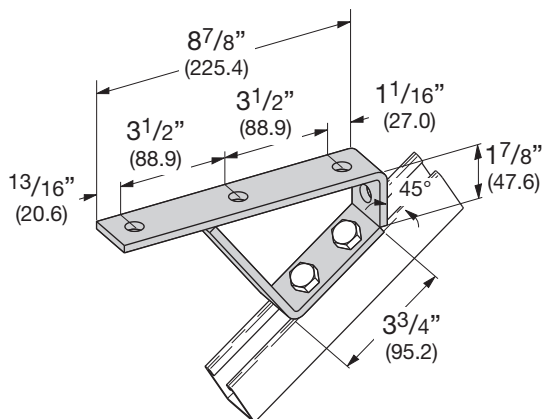

B562

37-1/2° STAIR SUPPORT

- Standard finishes: ZN, GRN
- Wt./C 206 Lbs. (93.4 kg)

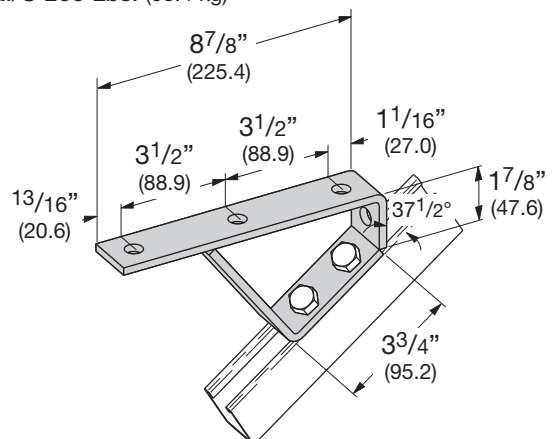

B376 FOUR BEARING TROLLEY ASSEMBLY

- Safety Factor of 2.5
- Stainless steel ball bearings
- Not for continuous cycling applications
- Standard finishes: ZN
- Wt./C 110 Lbs. (49.9 kg)

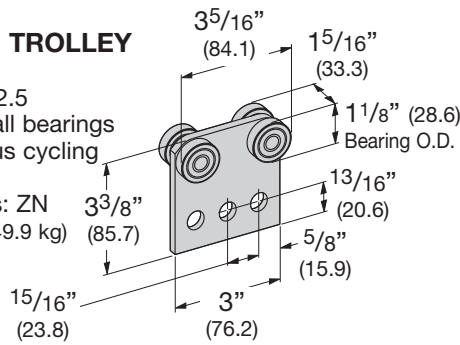

Design Load in B22		
Lbs.	kN	RPM
300	(1.33)	@600
450	(2.00)	@300
600	(2.67)	@100

Design Load

B377 TWO BEARING TROLLEY ASSEMBLY

- Safety Factor of 2.5
- Stainless steel ball bearings
- Not for continuous cycling applications
- Standard finishes: ZN
- Wt./C 48 Lbs. (21.8 kg)

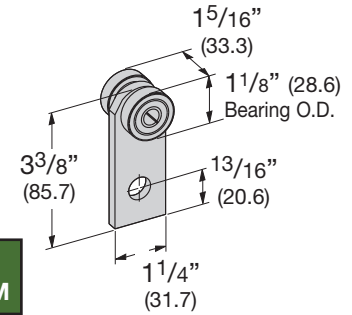

Design Load in B22		
Lbs.	kN	RPM
150	(.67)	@600
225	(1.00)	@300
437	(1.94)	@100

Design Load

B477 TWO BEARING LIGHT DUTY TROLLEY ASSEMBLY

- Design Load 50 Lbs. (.22 kN)
- Safety Factor of 2.5
- Stainless steel ball bearings
- Not for continuous cycling applications
- Material: 12 Gauge (2.6) ASTM A1011 33,000 PSI min. yield
- Standard finishes: ZN
- Wt./C 30 Lbs. (13.6 kg)

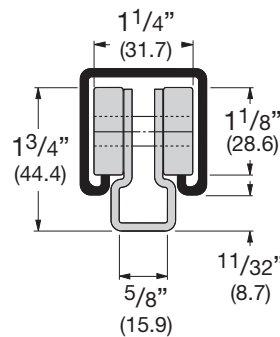

B477P WITH PLASTIC BEARINGS

- Design Load 10 Lbs. (.045 kN)

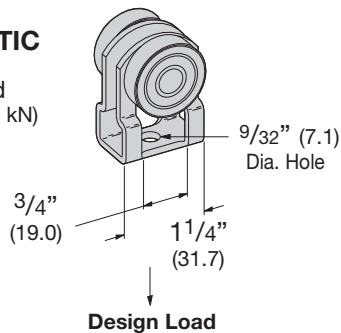

Design Load

B478 FOUR BEARING LIGHT DUTY TROLLEY ASSEMBLY

- Design Load 100 Lbs. (.44 kN)
- Safety Factor of 2.5
- Stainless steel ball bearings
- Not for continuous cycling applications
- Material: 12 Gauge (2.6) ASTM A1011 33,000 PSI min. yield
- Standard finishes: ZN
- Wt./C 68 Lbs. (30.8 kg)

B478P WITH PLASTIC BEARINGS

- Design Load 20 Lbs. (.090 kN)

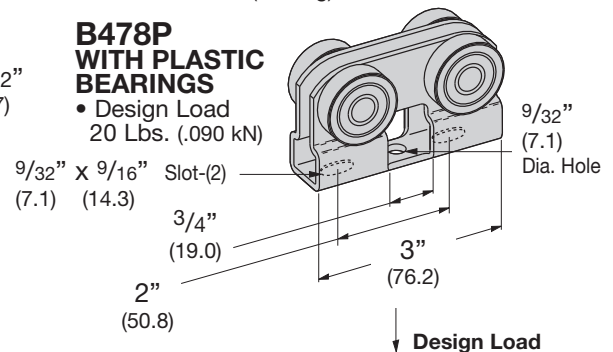

Design Load

B477H TWO BEARING LIGHT DUTY TROLLEY ASSEMBLY WITH EYE HOOK

- Design Load 50 Lbs. (.22 kN)
- Safety Factor of 2.5
- Stainless steel ball bearings
- Not for continuous cycling applications
- Material: 12 Gauge (2.6) ASTM A1011 33,000 PSI min. yield
- Standard finishes: ZN
- Wt./C 36 Lbs. (16.3 kg)

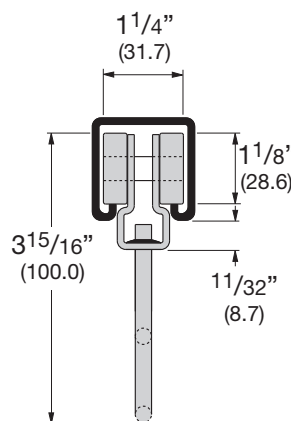

B477HP WITH PLASTIC BEARINGS

- Design Load 10 Lbs. (.045 kN)

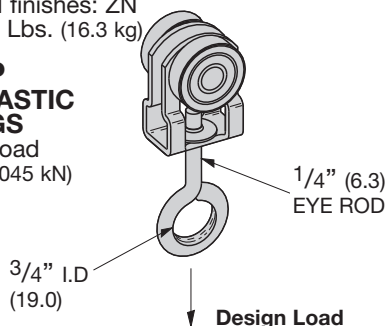

Design Load

B478H FOUR BEARING LIGHT DUTY TROLLEY ASSEMBLY WITH EYE HOOK

- Design Load 100 Lbs. (.44 kN)
- Safety Factor of 2.5
- Stainless steel ball bearings
- Not for continuous cycling applications
- Material: 12 Gauge (2.6) ASTM A1011 33,000 PSI min. yield
- Standard finishes: ZN
- Wt./C 72 Lbs. (32.6 kg)

B478HP WITH PLASTIC BEARINGS

- Design Load 20 Lbs. (.090 kN)

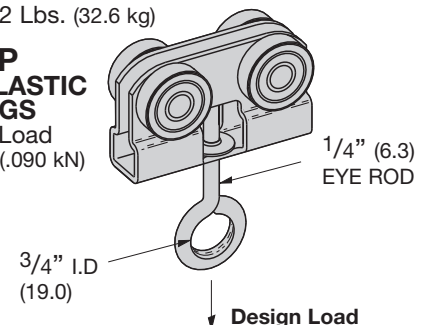

Design Load

Reference page 72 for general fitting and standard finish specifications.

Miscellaneous Fittings

B203-B206 & B220-B223 CHANNEL END CAPS TYPE X

- Material: ASTM A1011 CS Type B
- Standard finishes: ZN, GRN, HDG, SS4, AL

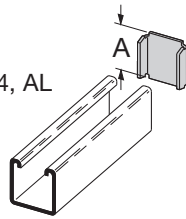

Part No.	Use With	A	(A)	Wt./C	
				Lbs.	kg
B203	B42	1.015	(25.8)	6	(2.7)
B204	B54	.827	(21.0)	5	(2.2)
B205	B22	1.640	(41.6)	10	(4.5)
B206	B32	1.390	(35.3)	8	(3.6)
B220	B52	.827	(21.0)	4	(1.8)
B221	B12	2.452	(62.3)	15	(6.8)
B222	B11	3.265	(82.9)	20	(9.1)
B223	B24	1.640	(41.6)	10	(4.5)

B283-B286 CHANNEL END CAPS

- Material: ASTM A1011 33,000 PSI min. yield
- Standard finishes: ZN, GRN

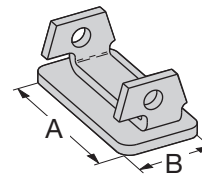

Part No.	Use With	A	(A)	B	(B)	Wt./C	
						Lbs.	kg
B283	B52	1 ¹⁹ / ₃₂ "	(40.5)	2 ⁵ / ₃₂ "	(19.8)	6	(2.7)
B284	B54 & B56	1 ¹⁹ / ₃₂ "	(40.5)	2 ⁵ / ₃₂ "	(19.8)	6	(2.7)
B285	B22	1 ¹⁹ / ₃₂ "	(40.5)	1 ¹⁹ / ₃₂ "	(40.5)	13	(5.9)
B286	B24 & B26	1 ¹⁹ / ₃₂ "	(40.5)	1 ¹⁹ / ₃₂ "	(40.5)	14	(6.3)

B287 & B288 CHANNEL END CAPS

- Material: ASTM A1011 33,000 PSI min. yield
- Standard finishes: ZN, GRN

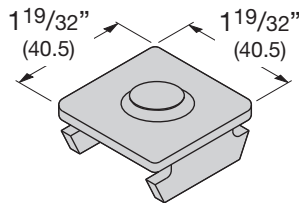

Part No.	Use With	Wt./C	
		Lbs.	kg
B287	B22	13	(5.9)
B288	B24	14	(6.3)

B3322, B3332, B3342, B3352 ANCHOR END CAPS TYPE Y

- Material: ASTM A1011 33,000 PSI min. yield
- Standard finishes: ZN

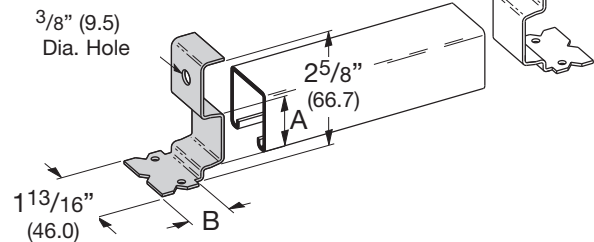

Part No.	Use With	A	(A)	B	(B)	Wt./C	
						Lbs.	kg
B3322	B22I	1.270	(32.2)	1 ³ / ₁₆ "	(30.2)	15	(6.8)
B3332	B32I	1.000	(25.4)	1 ³ / ₁₆ "	(30.2)	15	(6.8)
B3342	B42I	.645	(16.4)	1 ¹ / ₄ "	(31.8)	15	(6.8)
B3352	B52I	.460	(11.7)	1 ⁵ / ₁₆ "	(33.3)	15	(6.8)

B822 PLASTIC END CAP FOR B22 & B24

- Material: Soft White PVC
- Wt./C 3 Lbs. (1.3 kg)
- Available in colors: White (W), Yellow (Y), Black (BLK), Gray (GRY), Green (GRN)

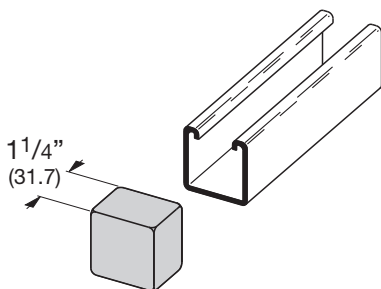

B822A PLASTIC END CAP FOR B22A & B11

- Material: Soft White PVC
- Wt./C 5 Lbs. (2.2 kg)
- Available in colors: White (W), Yellow (Y), Black (BLK), Gray (GRY), Green (GRN)

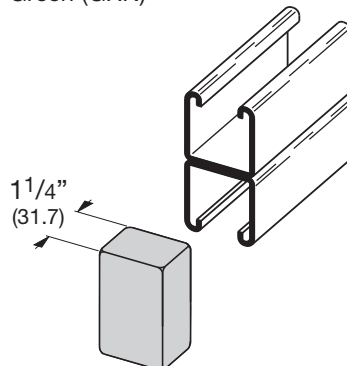

B852 PLASTIC END CAP FOR B52

- Material: Soft White PVC
- Wt./C 2.5 Lbs. (1.1 kg)
- Available in colors: White (W), Yellow (Y), Black (BLK), Gray (GRY), Green (GRN)

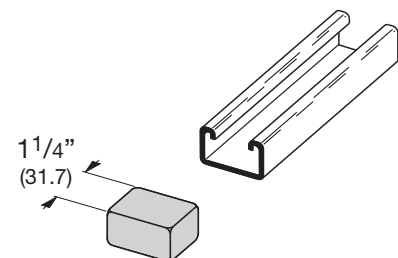

Reference page 72 for general fitting and standard finish specifications.

B823 PROFILE END CAPS

- Material: PVC
- Available in colors: White (W), Yellow (Y), Black (BLK), Gray (GRY), Green (GRN)

Approx. $\frac{3}{4}$ " deep
(19.0)

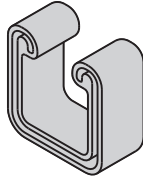

Part No.	Fits Channel Sizes	Wt./C	
		Lbs.	kg
B823-22A	B22A, B24A, B26A	6.9	(3.1)
B823-22	B22, B24, B26	4.1	(1.8)
B823-42	B42	3.8	(1.7)
B823-52	B52, B54, B56	3.5	(1.6)

B825 PLASTIC END CAPS

- Material: Polyurethane
- Available in colors: Gray (GRY), Green (GRN)

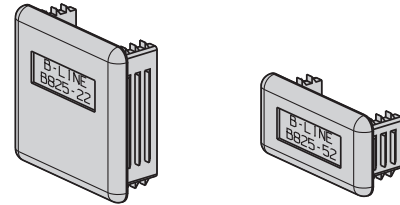

Part No.	Fits Channel Sizes	Wt./C	
		Lbs.	kg
B825-22	B22 & B24	2.0	(0.9)
B825-52	B52 & B54	1.0	(0.4)

B408SLBVNS Series STAND-OFF BRACKETS

- Material: $\frac{1}{4}$ " (6.3)
- Standard Finishes: HDG, ZN, GRN
- For pipe or rigid conduit sizes of $1\frac{1}{2}$ " (32) and 2" (50) use with B501 Series 'U'-Bolts
- For strut channels $1\frac{5}{8}$ " (41.3) wide use with B500 Series Square 'U'-Bolts
- Hardware is not included

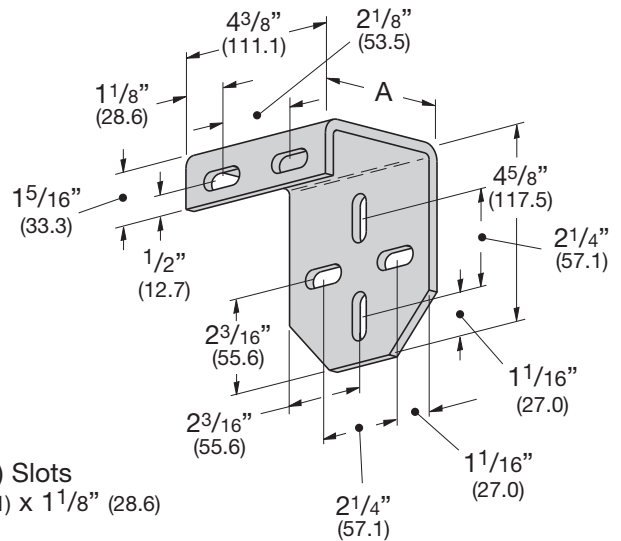
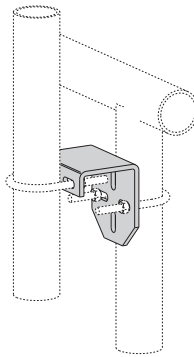

Part No.	A		Wt./C	
	In.	(mm)	Lbs.	kg
B408SLBVNS	$3\frac{1}{2}$ "	(88.9)	189	(85.7)
B408SLBVNS1	3"	(76.2)	220	(99.8)
B408SLBVNS2	2"	(50.8)	236	(107.0)

Reference page 72 for general fitting and standard finish specifications.

Beam Clamps

Our beam attachments and pipe supports offered in this section are designed to provide supports without drilling or welding. A complete selection of beam clamps, pipe clamps, rollers, supports and accessories are designed for use with B-Line channels and offer many installation advantages.

Materials & Finishes (Unless otherwise noted)

Pipe clamps, pipe hangers, beam clamps, brackets, and rollers are made from low carbon steel strips, plates or rod unless noted.

Finish Code	Finish	Specification
PLN	Plain	ASTM A1018 Gr. 33 ASTM A1011 SS Grade 33
ZN	Electro-Plated Zinc	ASTM B633 SC3 Type III or ASTM A653
GRN	DURA-GREEN™	
-	Malleable Iron	ASTM A47 Gr. 32510
HDG	Hot-Dipped Galvanized	ASTM A123
CZ	Chromium Zinc	ASTM F1136
SS4	Stainless Steel Type 304	ASTM A240
SS6	Stainless Steel Type 316	ASTM A240
AL	Aluminum	ASTM B209

Note: A minimum order may apply on special material and finishes.

Load Data

The load data published includes a safety factor of 5.0 unless noted (safety factor = ratio of ultimate load to the design load).

Recommended Torque For Setscrews (unless noted)

Setscrew Size	1/4"-20	3/8"-16	1/2"-13
Foot/Lbs.	4	5	11
Nm	5	7	15

Setscrew Size	5/8"-11	3/4"-10
Foot/Lbs.	21	34
Nm	28	46

See chart on page 72 for bolt torque.

Metric

Metric dimensions are shown in parentheses. Unless noted, all metric dimensions are in millimeters.



B351L STEEL C-CLAMP WITH LOCKNUT

- Safety Factor of 5
- Setscrew and locknut included
- When Retaining Strap is required, order B3362, B3363 or B3365 separately
- Standard finishes: ZN, SS4, PLN

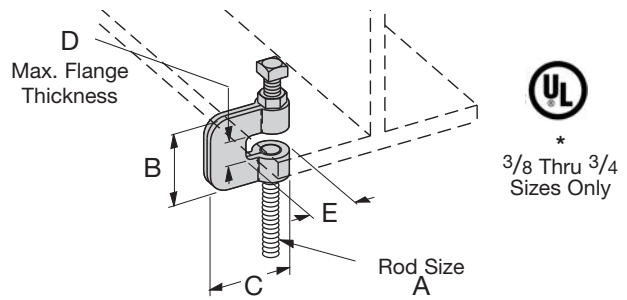

Part Number With Locknut	Rod Size A	B		C		D		E		Design Load		Wt./C	
		Lbs.	kg	Lbs.	kg	Lbs.	kg	Lbs.	kg	Lbs.	kg	Lbs.	kg
B351L-3/8 *	3/8"-16	2 3/8"	(60.3)	2 3/8"	(60.3)	3/4"	(19.0)	1 3/8"	(34.9)	230	(1.03)	41	(18.6)
B351L-1/2 *	1/2"-13	2 3/8"	(60.3)	2 3/8"	(60.3)	3/4"	(19.0)	1 3/8"	(34.9)	380	(1.71)	41	(18.6)
B351L-5/8 *	5/8"-11	2 3/8"	(60.3)	2 1/4"	(57.1)	3/4"	(19.0)	1 3/8"	(34.9)	550	(2.47)	60	(27.2)
B351L-3/4 *	3/4"-10	2 3/8"	(60.3)	3 1/4"	(82.5)	3/4"	(19.0)	1 3/8"	(34.9)	630	(2.83)	71	(32.2)
B351L-7/8	7/8"-9	3"	(76.2)	3 1/4"	(82.5)	1"	(25.4)	1 7/8"	(47.6)	1200	(5.34)	184	(83.4)

B3036L C-CLAMP WITH LOCKNUT

- Safety Factor of 5
- When Retaining Strap is required, order B3363 or B3364 separately
- Setscrew and locknut included
- Material: Malleable iron
- Standard finishes: ZN, PLN

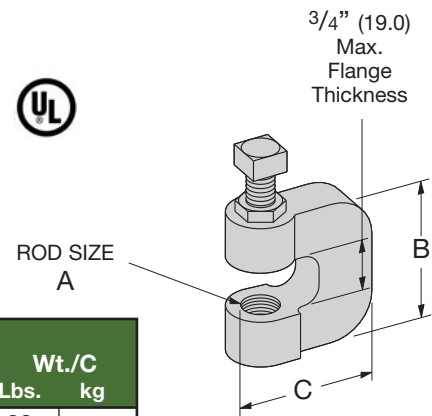

Part Number With Locknut	Rod Size A	B		C		Design Load		Wt./C	
		Lbs.	kg	Lbs.	kg	Lbs.	kg	Lbs.	kg
B3036L-3/8	3/8"-16	1 3/4"	(44.4)	1 3/4"	(44.4)	300	(0.89)	29	(13.1)
B3036L-1/2	1/2"-13	1 3/4"	(44.4)	1 3/4"	(44.4)	380	(1.69)	28	(12.7)
B3036L-5/8	5/8"-11	2"	(50.8)	1 7/8"	(47.6)	530	(2.36)	55	(24.9)
B3036L-3/4	3/4"-10	2"	(50.8)	2"	(50.8)	530	(2.36)	72	(32.6)

B3362 THRU B3365 RETAINING STRAP

- *When ordering specify L (Length) as a suffix to the part number
- Material: 14 Gauge (1.9)
- Standard finishes: GALV, SS4

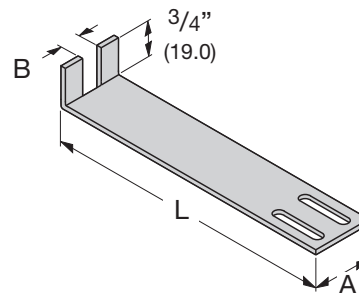

Part No.	Wt./C for Length L of				A	B	For Use With
	6" (152.4) Lbs. kg	8" (203.2) Lbs. kg	10" (254.0) Lbs. kg	12" (304.8) Lbs. kg			
B3362*	17 (7.7)	24 (10.9)	31 (14.0)	38 (17.2)	1 1/4" (31.7)	7/16" (11.1)	B351-3/8 & 1/2
B3363*	16 (7.2)	23 (10.4)	30 (13.6)	37 (16.8)	1 1/4" (31.7)	5/8" (15.9)	B351-5/8 & 3/4 B3036-3/8 & 1/2
B3364*	16 (7.2)	23 (10.4)	30 (13.6)	37 (16.8)	1 1/4" (31.7)	1 1/16" (17.4)	B3036-5/8 & 3/4
B3365*	21 (9.5)	29 (13.1)	37 (16.8)	46 (20.8)	1 1/2" (38.1)	3/4" (19.0)	B351-7/8

*See note above.

Reference page 112 for general fitting and standard finish specifications.

Beam Clamps

B3033 REVERSIBLE WIDE JAW WEDGE C-CLAMP (MALLEABLE IRON)

- Safety Factor of 5
- Setscrew and locknut included
- Material: Malleable iron
- Standard finishes: ZN, PLN

Throat Openings
 1 1/4" (31.7) For
 3/8 & 1/2 Sizes
 1 5/16" (33.3) For
 5/8 & 3/4 Sizes

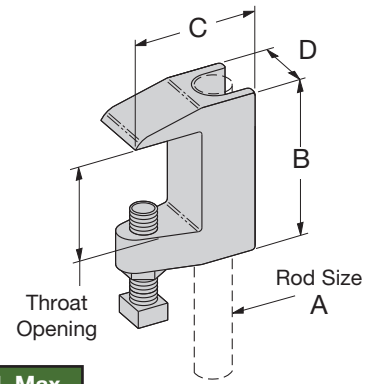

Part No.	Rod Size A	B	C	D	Design Load Lbs. kN	Wt./C Lbs. kg	UL Max. Pipe Size
B3033-3/8	3/8"-16	2 1/4" (57.1)	2" (50.8)	1 1/8" (28.6)	500 (2.22)	46 (20.8)	4" (100)
B3033-1/2	1/2"-13	2 5/16" (58.7)	2 3/16" (55.5)	1 1/4" (31.7)	810 (3.60)	64 (29.0)	8" (200)
B3033-5/8	5/8"-11	2 5/8" (66.7)	2 1/2" (63.5)	1 3/8" (34.9)	1000 (4.48)	116 (52.6)	8" (200)
B3033-3/4	3/4"-10	2 11/16" (68.3)	2 1/2" (63.5)	1 7/16" (36.5)	1400 (6.22)	140 (63.5)	10" (250)

B3034 WEDGE C-CLAMP

- Safety Factor of 5
- 3/4" (19.0) Max. Flange Thickness
- Setscrew and locknut included
- Material: Malleable iron
- Standard finishes: ZN, PLN

Note:
 3/8" & 1/2" Sizes
 Are Reversible
 Style



*
 3/8 & 1/2
 Sizes Only

3/4" (19.0) Max.
 Flange Thickness

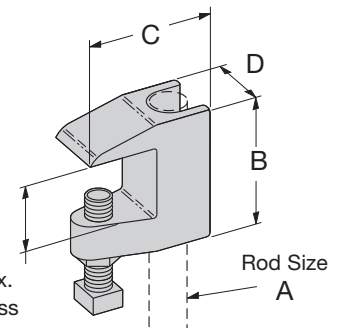

Part No.	Rod Size A	B	C	D	Design Load Lbs. kN	Wt./C Lbs. kg	UL Max. Pipe Size
B3034-3/8*	3/8"-16	1 5/8" (41.3)	2" (50.8)	7/8" (22.2)	560 (2.49)	54 (24.5)	4" (100)
B3034-1/2*	1/2"-13	1 13/16" (46.0)	2 3/16" (55.5)	1 3/16" (30.2)	810 (3.60)	51 (23.1)	8" (200)
B3034-5/8	5/8"-11	1 3/4" (44.5)	2 1/8" (54.0)	1 1/8" (28.6)	1000 (4.48)	70 (31.7)	-- --
B3034-3/4	3/4"-10	2" (50.8)	2 1/4" (57.2)	1 1/8" (28.6)	1500 (6.67)	98 (44.4)	-- --

Fig. 65XT REVERSIBLE C-TYPE BEAM CLAMP

- Safety Factor of 5
- 3/4" (19.0) Max. Flange Thickness
- Setscrew and locknut included
- Maximum Pipe Size 4" (100)
- Design Load 610 Lbs. (2.71kN)
- Material: Steel
- Standard finishes: ZN, PLN



Rod Size
 3/8"-16

3/4" (19.0) Max.
 Flange Thickness

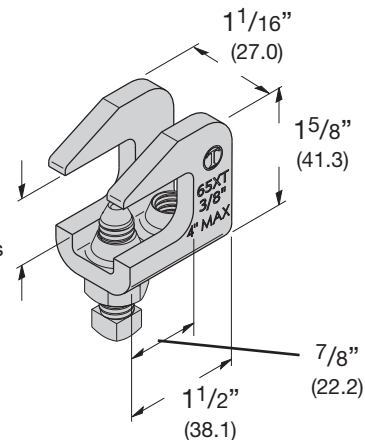

Reference page 112 for general fitting and standard finish specifications.

Fig. 69 (Formally B-Line B3367)
RETAINING STRAP

- Specify 'L' lengths required
- Minimum recommended return on strap is 1" (25.4)
- Material: Pre-Galvanized Steel
- Standard finishes: GALV

Part No.	Hole Dia. D		For Use With	Wt./C**	
	Lbs.	kg		Lbs.	kg
69-3/8-L	7/16"	(30.1)	B3033-3/8 & B3034-3/8 65XT-3/8	23.9	(10.8)
69-1/2-L	9/16"	(30.1)	B3033-1/2 & B3034-1/2	23.6	(10.7)
69-5/8-L	11/16"	(50.8)	B3033-5/8	23.2	(10.5)
69-3/4-L	13/16"	(63.5)	B3033-3/4	22.7	(10.3)

** Wt./C based on 6" (152.4) length. For each additional inch in strap length add 4.2 Lbs (1.9 kg) to Wt./C.

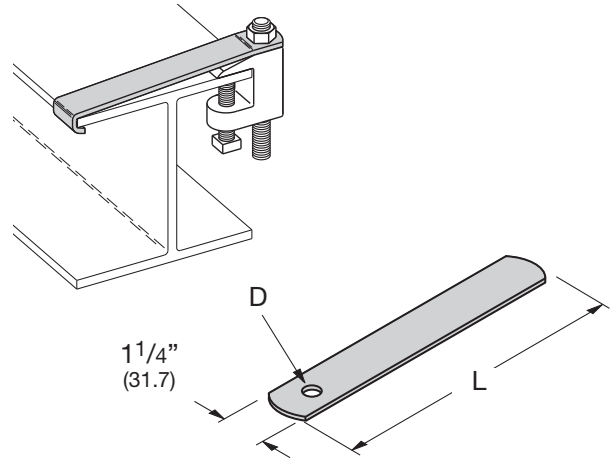
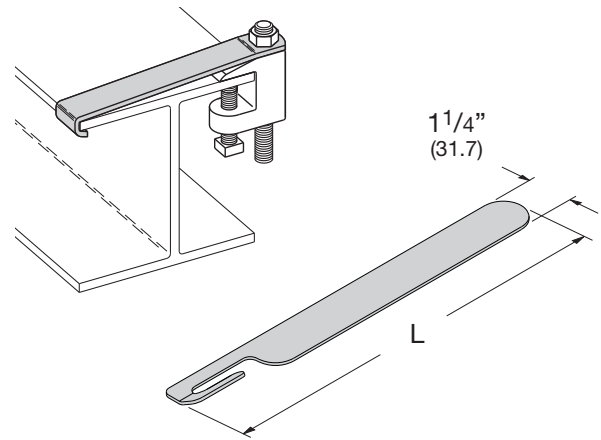

Fig. 69R
RETROFIT RETAINING STRAP

- Specify 'L' lengths required
- Minimum recommended return on strap is 1" (25.4)
- Material: Pre-Galvanized Steel
- Standard finishes: GALV

Part No.	Slot Width		For Use With	Wt./C**	
	Lbs.	kg		Lbs.	kg
69R-3/8-L	7/16"	(30.1)	B3033-3/8 & B3034-3/8 65XT-3/8	22.9	(10.4)
69R-1/2-L	9/16"	(30.1)	B3033-1/2 & B3034-1/2	22.6	(10.2)

** Wt./C based on 6" (152.4) length. For each additional inch in strap length add 4.2 Lbs (1.9 kg) to Wt./C.



B3037Z
Z-PURLIN C-CLAMP

- Design Load 500 Lbs. (2.22 kN)
- Safety Factor of 5
- Designed for attaching a 3/8"-16 hanger rod to the bottom flange of a Z-purlin
- Setscrew and locknut included
- Material: Malleable iron
- Standard finishes: ZN, PLN

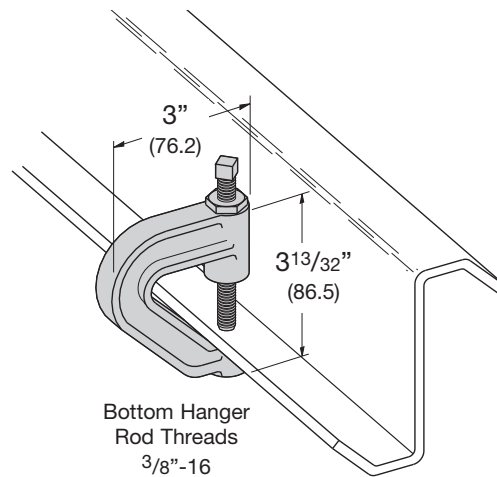

Reference page 112 for general fitting and standard finish specifications.

Beam Clamps

B444 SERIES ROD SUPPORT

- Safety Factor of 5
- Max. Flange Thickness
3/4" (19.0) for 1/4" & 5/16" sizes
1" (25.4) for 3/8" & 1/2" sizes
- Setscrew included
- Material: Malleable iron
- Standard finish: ZN
Available in HDG with CZ Hardware

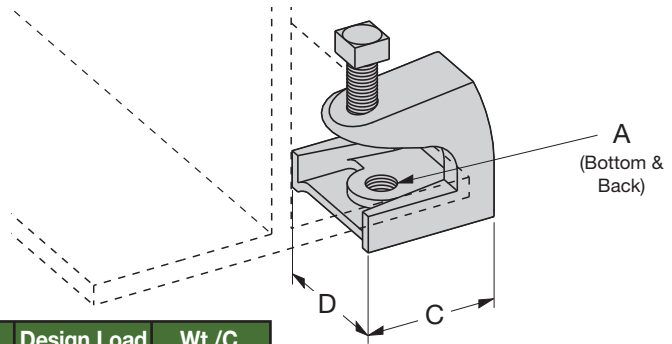

Part No.	Thread Size A	Set Screw	C	D	Design Load		Wt./C	
					Lbs.	kN	Lbs.	kg
B444-1/4	1/4"-20	1/4"-20	1 3/8" (34.9)	1 3/16" (30.1)	150	(.66)	24	(10.9)
B444-5/16	5/16"-18	1/4"-20	1 3/8" (34.9)	1 3/16" (30.1)	150	(.66)	23	(10.4)
B444-3/8	3/8"-16	1/2"-13	1 7/8" (47.6)	2" (50.8)	350	(7.12)	65	(29.5)
B444-1/2	1/2"-13	5/8"-11	2 3/8" (60.3)	2 1/2" (63.5)	1000	(4.45)	132	(59.9)

BC442 LIGHT DUTY BEAM CLAMP

- Design Load 75 Lbs. (.33 kN)
- Safety Factor of 5
- 1 1/16" (17.5) Max. Flange Thickness
- Setscrew included
- Holes tapped 1/4"-20 (Bottom & Back)
- Material: 13 Gauge (2.3)
- Standard finish: ZN
- Wt./C 13 Lbs. (3.9 kg)

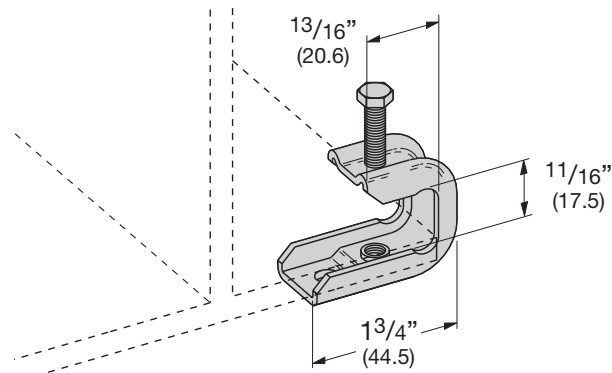

B210 BEAM CLAMP

- Design Load 800 Lbs. (3.56 kN)
- Safety Factor of 5
- 5/8" (15.9) Max. Flange Thickness
- 1/2"-13 Setscrew included
- Standard finish: ZN
- Wt./C 100 Lbs. (45.3 kg)

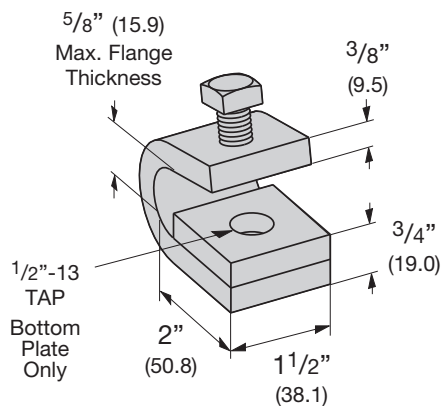

B210A BEAM CLAMP

- Design Load 300 Lbs. (1.33 kN)
- Safety Factor of 5
- 3/4" (19.0) Max. Flange Thickness
- 3/8"-16 Setscrew included
- Standard finish: ZN
- Wt./C 60 Lbs. (27.2 kg)

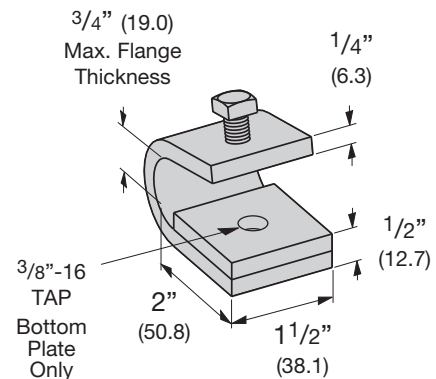

Reference page 112 for general fitting and standard finish specifications.

B303 THRU B309 BEAM CLAMPS

- Safety Factor of 5
- Max. Flange Thickness $\frac{1}{16}$ " (1.6) thru $\frac{7}{8}$ " (22.2)
- Setscrew included
- When Retaining Strap is required, order B312 separately
- Recommended Setscrew Torque: $\frac{3}{8}$ "-16 150 in-lbs. (16.9 N•m)
 $\frac{1}{2}$ "-13 350 in-lbs. (39.5 N•m)
- Standard finishes: ZN, HDG

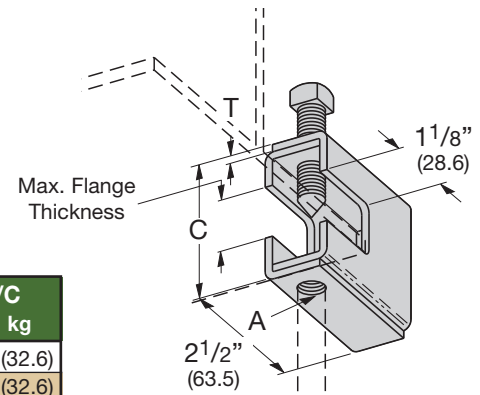

Part No.	Rod Size A	Set Screw	C	T	Design Load		Wt./C	
					Lbs.	kN	Lbs.	kg
B303	$\frac{1}{4}$ "-20	$\frac{3}{8}$ "-16	$2\frac{5}{16}$ " (58.7)	11 Ga. (3.0)	400 (1.78)	72 (32.6)		
B304	$\frac{5}{16}$ "-18	$\frac{3}{8}$ "-16	$2\frac{5}{16}$ " (58.7)	11 Ga. (3.0)	600 (2.67)	72 (32.6)		
B305	$\frac{3}{8}$ "-16	$\frac{3}{8}$ "-16	$2\frac{5}{16}$ " (58.7)	11 Ga. (3.0)	600 (2.67)	72 (32.6)		
B306	$\frac{3}{8}$ "-16	$\frac{1}{2}$ "-13	$2\frac{7}{16}$ " (61.9)	7 Ga. (4.5)	1100 (4.89)	97 (44.0)		
B307	$\frac{1}{2}$ "-13	$\frac{1}{2}$ "-13	$2\frac{7}{16}$ " (61.9)	7 Ga. (4.5)	1100 (4.89)	97 (44.0)		
B308	$\frac{1}{2}$ "-13	$\frac{1}{2}$ "-13	$2\frac{9}{16}$ " (65.1)	$\frac{1}{4}$ " (6.3)	1500 (6.67)	133 (60.3)		
B309	$\frac{5}{8}$ "-11	$\frac{1}{2}$ "-13	$2\frac{9}{16}$ " (65.1)	$\frac{1}{4}$ " (6.3)	1500 (6.67)	133 (60.3)		

B321 SERIES BEAM CLAMPS

- Safety Factor of 5
- $1\frac{1}{16}$ " (42.8) Max. Flange Thickness
- Setscrew included
- When Retaining Strap is required, order B312 separately
- Recommended Setscrew Torque: $\frac{1}{2}$ "-13 350 in-lbs. (39.5 N•m)
 $\frac{5}{8}$ "-11 700 in-lbs. (79.0 N•m)
- Minimum flange thickness: B321-1 thru B321-3 $\frac{1}{4}$ " (6.3)
B321-4 and B321-5 $\frac{3}{8}$ " (9.5)
- Standard finishes: ZN, HDG

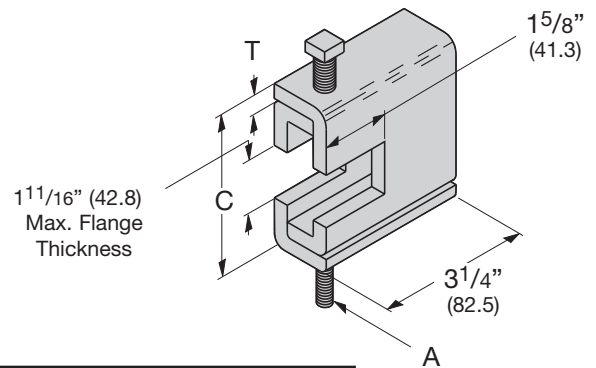

Part No.	Rod Size A	Setscrew	C	T	Design Load		Wt./C	
					Lbs.	kN	Lbs.	kg
B321-1	$\frac{3}{8}$ "-16	$\frac{1}{2}$ "-13	$3\frac{9}{16}$ " (92.1)	$\frac{1}{4}$ " (6.3)	1300 (5.78)	187 (84.8)		
B321-2	$\frac{1}{2}$ "-13	$\frac{1}{2}$ "-13	$3\frac{9}{16}$ " (92.1)	$\frac{1}{4}$ " (6.3)	1400 (6.23)	186 (84.3)		
B321-3	$\frac{5}{8}$ "-11	$\frac{1}{2}$ "-13	$3\frac{9}{16}$ " (92.1)	$\frac{1}{4}$ " (6.3)	1600 (7.12)	185 (83.9)		
B321-4	$\frac{5}{8}$ "-11	$\frac{5}{8}$ "-11	$3\frac{23}{32}$ " (94.4)	$\frac{5}{16}$ " (7.9)	1800 (8.00)	239 (108.4)		
B321-5	$\frac{3}{4}$ "-10	$\frac{5}{8}$ "-11	$3\frac{23}{32}$ " (94.4)	$\frac{5}{16}$ " (7.9)	2000 (8.89)	238 (107.9)		

B312 SERIES RETAINING STRAP FOR USE WITH B303 THRU B309 AND B321 SERIES

- $\frac{3}{4}$ " (19.0) Max. Flange Thickness
- For thicker beams, step up one flange width size
- Material: 14 Gauge (1.9)
- Standard finishes: GALV, HDG

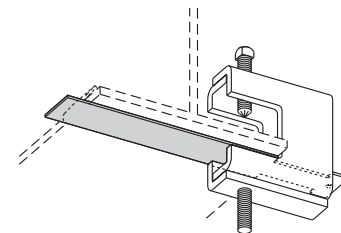

Part No.	For Flange Width		A	Wt./C	
	Lbs.	kg		Lbs.	kg
B312-6	6"	(152.4)	9"	(228.6)	22 (10.0)
B312-9	9"	(228.6)	12"	(304.8)	30 (13.6)
B312-12	12"	(304.8)	15"	(381.0)	40 (18.1)
B312-15	15"	(381.0)	18"	(457.2)	49 (22.2)

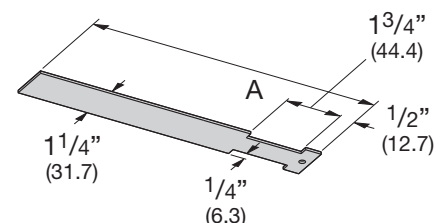

Reference page 112 for general fitting and standard finish specifications.

Beam Clamps

B751 BEAM CLAMP

- Safety Factor of 5
- 3/4" (19.0) Max. Flange Thickness
- Setscrew and Locknut included
- Maximum ATR Size 1/2"
- Use B753 Swivel Nut (not included)
- Material: 12 Gauge (2.6)
- Standard finish: ZN, HDG
- Wt./C 42 Lbs. (19.0 kg)

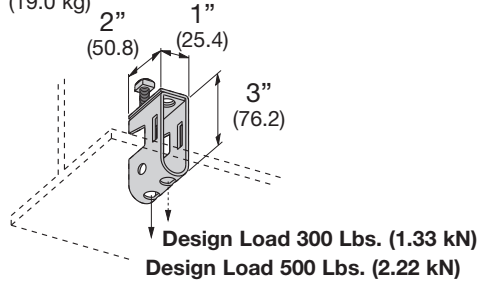

B752 BEAM CLAMP SWIVEL

- Design Load 500 Lbs. (2.22 kN)
- Safety Factor of 5
- Material: 12 Gauge (2.6)
- Use B753 Swivel Nut (not included)
- Includes:
 - 1 pc. B752 Swivel Body
 - 1 pc. 5/16"-18 x 1 3/4" HHCS
 - 1 pc. 5/16"-18 Hex Nut
- Standard finish: ZN
- Wt./C 30 Lbs. (13.6 kg)

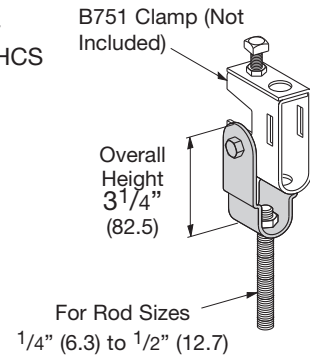

B751-J_-3/8 BEAM CLAMP ASSEMBLY

- Includes:
 - 1 pc. B751 Beam Clamp
 - 1 pc. B701 Type J-Hook only
 - 1 pc. SA203-158 Clip
 - 1 pc. 3/8"-16 Hex Nut
- 1/4" (6.3) Diameter J-Hook available upon request
Part Number changes to B751-J_-1/4 and a 1/4-20 Machine Square Nut (MSQN) is used
- Use B753 Swivel Nut (not included)
- Standard finishes: ZN

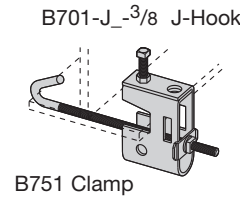

Part No.	For Flange Width		Wt./C	
			Lbs.	kg
B751-J4-3/8	3"-6"	(76.2-152.4)	70	(31.7)
B751-J6-3/8	5"-9"	(127.0-228.6)	78	(35.4)
B751-J9-3/8	8"-12"	(203.2-304.8)	83	(37.6)
B751-J12-3/8	11"-15"	(279.4-381.0)	88	(39.9)

B753 SWIVEL NUT

- Provides a full swivel of 15° in any direction
Specify rod size
- Standard finish: ZN

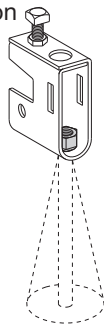

Part No.	For Rod Size	Wt./C	
		Lbs.	kg
B753-3/8	3/8"-16	4.0	(1.8)
B753-1/2	1/2"-13	3.4	(1.5)

B701 SERIES J-HOOK

- 1/4" (6.3) Diameter J-Hook available upon request
Part Number changes to B751-J_-1/4 and a 1/4-20 Machine Square Nut (MSQN) is used
- Standard finish: ZN

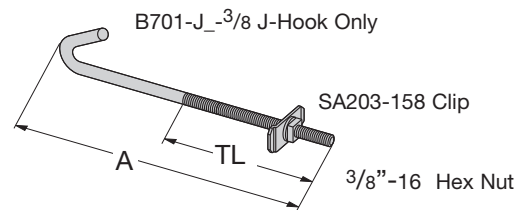

Part No.	A	Thread Length TL		Wt./C	
		Lbs.	kg	Lbs.	kg
B701-J4-3/8	8 3/4"	(222.2)	5 1/2"	(139.7)	26 (11.8)
B701-J6-3/8	11 3/4"	(298.4)	6 1/2"	(165.1)	34 (15.4)
B701-J9-3/8	14 3/4"	(374.6)	6 1/2"	(165.1)	41 (18.6)
B701-J12-3/8	17 3/4"	(450.8)	6 1/2"	(165.1)	48 (21.8)

Reference page 112 for general fitting and standard finish specifications.

B755 3/8" BEAM CLAMP

- Safety Factor of 5
- 5/8" (15.9) Max. Flange Thickness
- For 3/8"-16 Hanger Rod only
- Material: 12 Gauge (2.6)
- Includes:
 - 1 pc. B755 Beam Clamp
 - 1 pc. 3/8" x 2" Square Head Set Screw
 - 2 pcs. 3/8" Square Nut
- Standard finish: ZN
- Wt./C 30 Lbs. (13.6 kg)

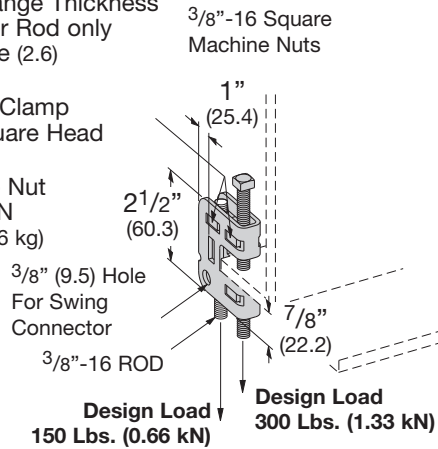

B756-3/8 SWING CONNECTOR

- Design Load 150 Lbs. (0.66 kN)
- Safety Factor of 5
- Material: 12 Gauge (2.6)
- Includes:
 - 1 pc. B756-3/8 Swing Connector Body
 - 1 pc. 5/16"-18 x 1 1/4" SHHMS
 - 1 pc. 5/16"-18 Square Nut
- Use B753 Swivel Nut (not included)
- Standard finish: ZN
- Wt./C 15 Lbs. (6.8 kg)

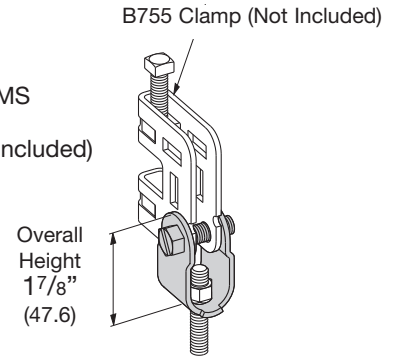

B755-3/8-J BEAM CLAMP ASSEMBLY

- Includes:
 - 1 pc. B755-3/8 Beam Clamp
 - 1 pc. B705 Type J-Hook only
 - 1 pc. B705 Clip
 - 1 pc. 1/4"-20 Square Nut
- Standard finish: ZN

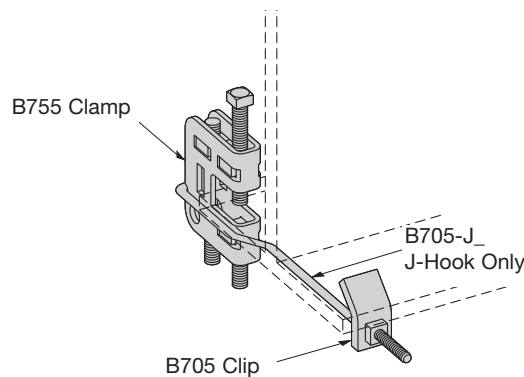

Part No.	For Flange Width		Wt./C	
			Lbs.	kg
B755-3/8-J4	4"-6"	(101.6-152.4)	47	(21.3)
B755-3/8-J6	6"-10"	(152.4-254.0)	51	(23.1)
B755-3/8-J10	10"-12"	(254.0-304.8)	53	(24.0)
B755-3/8-J12	12"-14"	(304.8-355.6)	55	(24.9)

B702 CLEAT

- To eliminate the swiveling of the rod when required, use the B702 Cleat and a locking nut. This can be used with the B751 Beam Clamp, B752 Swivel or B756 Swing Connector.
- Material: 12 Gauge (2.6)
- Standard finish: ZN
- Wt./C 6 Lbs. (2.7 kg)

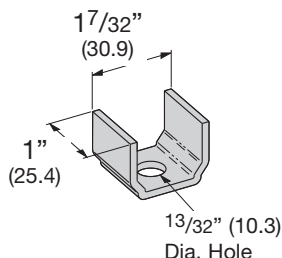

B705 SERIES

J-HOOK

- Use with B755-3/8
- Standard finish: ZN

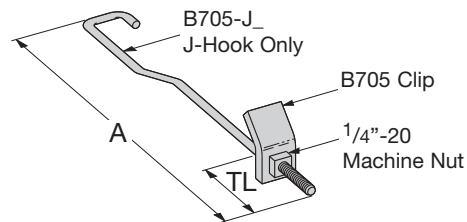

Part No.	A	Thread Length TL		Wt./C	
		Lbs.	kg	Lbs.	kg
B705-J4	7 3/8"	(187.3)	3"	(76.2)	17 (7.7)
B705-J6	11 3/8"	(288.9)	4 1/2"	(114.3)	21 (9.5)
B705-J10	13 3/8"	(339.7)	4 1/2"	(114.3)	23 (10.4)
B705-J12	15 3/8"	(390.5)	4 1/2"	(114.3)	25 (11.3)

Reference page 112 for general fitting and standard finish specifications.

Beam Clamps

B750 SERIES BEAM CLAMP

- Safety Factor of 5
- Design Load 500 Lbs. (2.22 kN)
- Recommended Torque:
J-Hook Nut 125 in-lbs. (14.1 N•m)
- Maximum Flange Thickness $\frac{5}{8}$ " (15.9)
- Standard finish: ZN

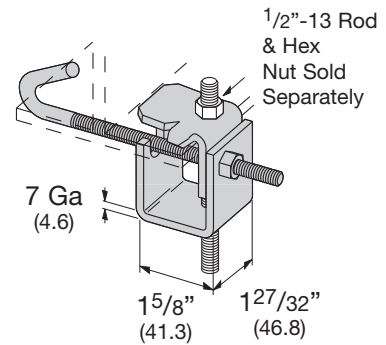

Part No.	For Flange Width		Wt./C	
			Lbs.	kg
B750-J4	3"-6"	(76.2-152.4)	109	(49.4)
B750-J6	5"-9"	(127.0-228.6)	124	(56.2)
B750-J9	8"-12"	(203.2-304.8)	135	(61.2)
B750-J12	11"-15"	(279.4-381.0)	147	(66.7)

B700 SERIES J-HOOK

- Includes:
1 pc. J-Bolt
1 pc. Hex Nut
- Maximum Flange Thickness $\frac{5}{8}$ " (15.9)
- Standard finish: ZN

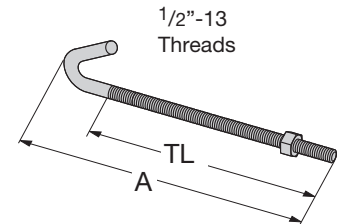

Part No.	A		Thread Length TL		Wt./C	
	Lbs.	kg	Lbs.	kg	Lbs.	kg
B700-J4	8 $\frac{1}{2}$ "	(215.9)	6 $\frac{3}{4}$ "	(171.4)	44	(19.9)
B700-J6	11 $\frac{1}{2}$ "	(292.1)	9 $\frac{3}{4}$ "	(247.6)	53	(24.0)
B700-J9	14 $\frac{1}{2}$ "	(368.3)	12 $\frac{3}{4}$ "	(323.8)	63	(28.6)
B700-J12	17 $\frac{1}{2}$ "	(444.5)	15 $\frac{3}{4}$ "	(400.0)	78	(35.4)

B500 SERIES SQUARE U-BOLT

- Includes:
1 pc. U-Bolt only
2 pcs. $\frac{3}{8}$ "-16 Hex Nuts
- Additional sizes available
- Standard finish: ZN, SS4

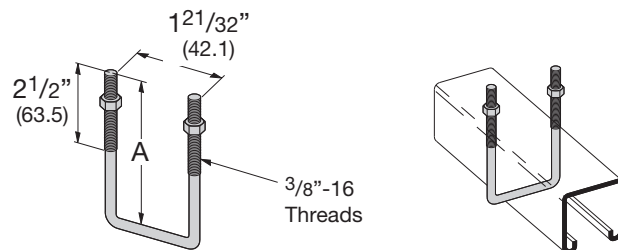

Part No.	A		Channel Size	Wt./C	
	Lbs.	kg		Lbs.	kg
B500-3-$\frac{3}{8}$	3 $\frac{3}{8}$ "	(85.7)	1 $\frac{5}{8}$ " x 1 $\frac{5}{8}$ "	25	(11.3)
B500-5	5"	(127.0)	3 $\frac{1}{4}$ " x 1 $\frac{5}{8}$ "	33	(14.9)

Reference page 112 for general fitting and standard finish specifications.

B441-22 BEAM CLAMP

- Design Load 1200 Lbs. (5.34 kN) when used in pairs
- Safety Factor of 5
- 3/4" (19.0) Max. Flange Thickness
- For use with 13/16" (20.6) to 15/8" (41.3) high channel
- Recommended Torque: 150 in-lbs. (16.9 N•m)
- Sold in pieces
- Other flange thickness variations are available, contact B-Line Engineering for sizes
- Standard finishes: ZN, HDG, SS4
- Wt./C 87 Lbs. (39.4 kg)

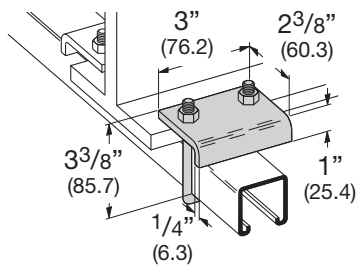

B441-22A BEAM CLAMP

- Design Load 1200 Lbs. (5.34 kN) when used in pairs
- Safety Factor of 5
- 3/4" (19.0) Max. Flange Thickness
- For use with 15/8" (41.3) to 3 1/4" (82.5) high channel
- Recommended Torque: 150 in-lbs. (16.9 N•m)
- Sold in pieces
- Other flange thickness variations are available, contact B-Line Engineering for sizes
- Standard finishes: ZN, HDG, SS4
- Wt./C 93 Lbs. (42.2 kg)

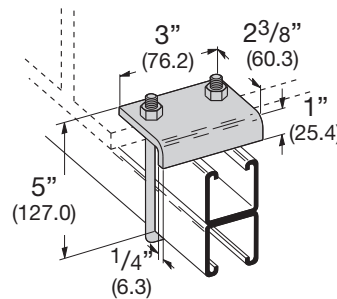

B314 BEAM CLAMP

- Design Load 900 Lbs. (4.00 kN) when used in pairs
- Safety Factor of 5
- 5/8" (15.9) Max. Flange Thickness
- For use with channel 15/8" (41.3) in height
- Setscrew included
- Sold in pieces
- Standard finishes: ZN, GRN, HDG, SS4
- Wt./C 105 Lbs. (47.6 kg)

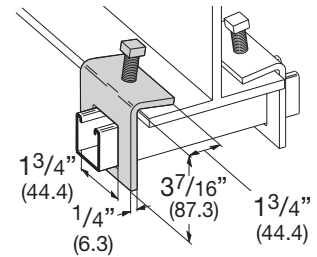

B441Z-22 BEAM CLAMP

- Design Load 1200 Lbs. (5.34 kN) when used in series
- Safety Factor of 5
- Sold in pieces
- For use with 13/16" (20.6) to 15/8" (41.3) high channel
- Recommended Torque: 150 in-lbs. (16.9 N•m)
- Standard finishes: ZN
- Wt./C 95 Lbs. (43.1 kg)

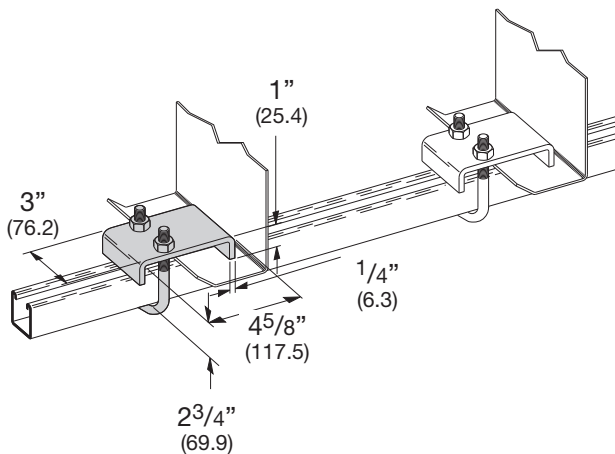

B441Z-22A BEAM CLAMP

- Design Load 1200 Lbs. (5.34 kN) when used in series
- Safety Factor of 5
- Sold in pieces
- For use with 15/8" (41.3) to 3 1/4" (82.5) high channel
- Recommended Torque: 150 in-lbs. (16.9 N•m)
- Standard finishes: ZN
- Wt./C 101 Lbs. (45.8 kg)

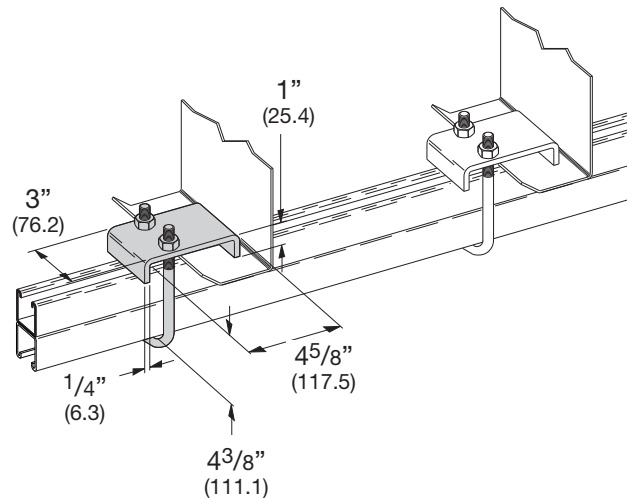

Reference page 112 for general fitting and standard finish specifications.

Beam Clamps

B211 ZEE BEAM CLAMP

- Design Load 600 Lbs. (2.67 kN) when used in pairs
- Safety Factor of 5
- 1" (25.4) Max. Flange Thickness
- 1/2"-13 Setscrew included
- Sold in pieces
- Order 1/2"-13 HHCS and Channel Nut separately
- Standard finishes: ZN, HDG
- Wt./C 66 Lbs. (29.9 kg)

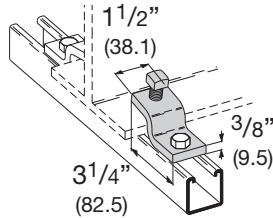

B213 I-BEAM CLAMP

- Design Load 900 Lbs. (4.00 kN) when used in pairs
- Safety Factor of 5
- 7/8" (22.2) Max. Flange Thickness
- 1/2"-13 Setscrew included
- Sold in pieces
- Order 1/2"-13 x 2 1/4" HHCS and Channel Nut separately
- Material: Malleable iron
- Standard finishes: ZN, GRN
- Wt./C 95 Lbs. (43.1 kg)

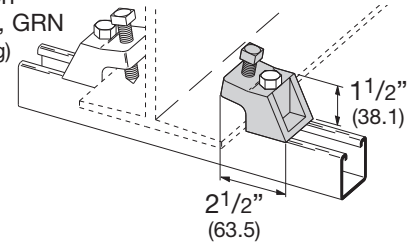

B355 BEAM CLAMP

- Design Load 1200 Lbs. (5.34 kN) when used in pairs
- Safety Factor of 5
- 5/8" (15.9) Max. Flange Thickness
- Sold in pieces
- Order 1/2"-13 x 1 1/2" HHCS and Channel Nut separately
- Standard finishes: ZN, GRN, HDG, SS4
- Wt./C 30 Lbs. (13.6 kg)

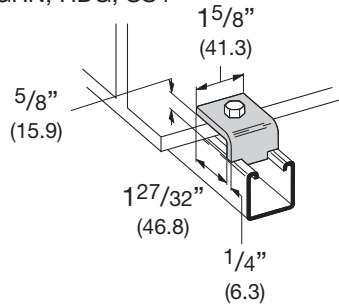

B212-1/4 I-BEAM CLAMP

- Design Load 600 Lbs. (2.67 kN) when used in pairs
- Safety Factor of 5
- 7/8" (22.2) Max. Flange Thickness
- 3/8"-16 Setscrew included
- Sold in pieces
- Standard finish: ZN
- Wt./C 41 Lbs. (18.6 kg)

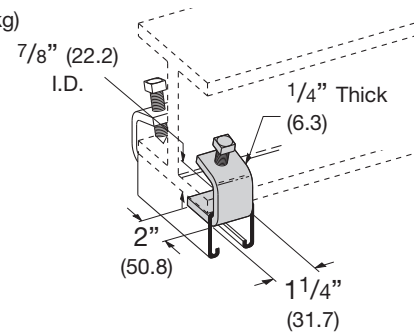

B212-3/8 I-BEAM CLAMP

- Design Load 1000 Lbs. (4.45 kN) when used in pairs
- Safety Factor of 5
- 1 1/8" (28.6) Max. Flange Thickness
- 1/2"-13 Setscrew included
- Sold in pieces
- Standard finishes: ZN, HDG
- Wt./C 62 Lbs. (28.1 kg)

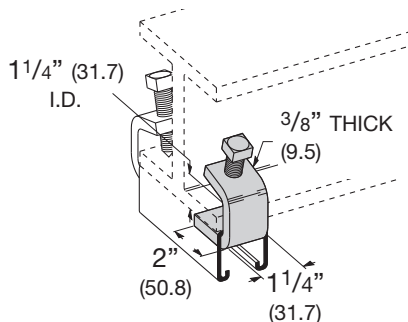

B435 BEAM CLAMP

- Design Load 900 Lbs. (4.00 kN) when used in pairs
- Safety Factor of 5
- 2 1/8" (54.0) Max. Flange Thickness
- 1/2"-13 x 2" Setscrew included
- Sold in pieces
- Standard finish: ZN
- Wt./C 82 Lbs. (37.2 kg)

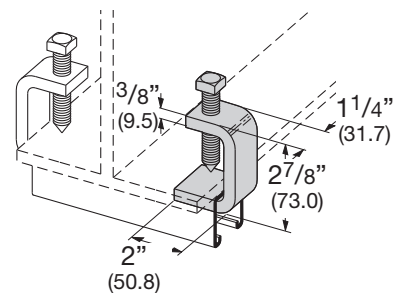

Reference page 112 for general fitting and standard finish specifications.

B427 BEAM CLAMP

- Design Load 1100 Lbs. (4.89 kN) when used in pairs
- Safety Factor of 5
- 2 1/2" (63.5) Max. Flange Thickness without channel
- 1/2"-13 x 1 1/2" Setscrew included
- Sold in pieces
- Standard finish: ZN
- Wt./C 92 Lbs. (41.7 kg)

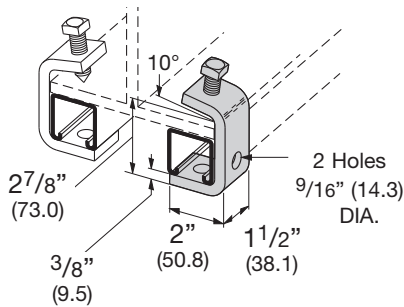

B405 SUSPENSION MEMBER

- Standard finishes: ZN, GRN
- Wt./C 75 Lbs. (34.0 kg)

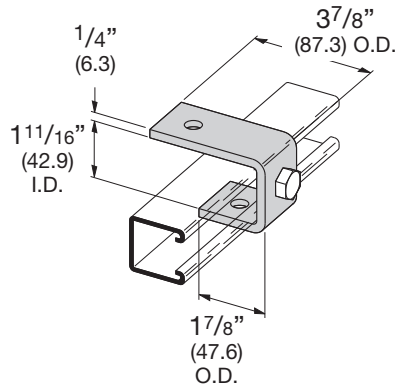

B405A SUSPENSION MEMBER WITH BEAM CLAMP

- 7/8" (22.2) Max. Flange Thickness
- Includes:
 - 1 pc. B405 Suspension Member
 - 1 pc. B213 I-Beam Clamp
 - 1 pc. 1/2"-13 x 2 1/2" HHCS
 - 1 pc. 1/2"-13 Hex Nut
- Material: Malleable iron
- Standard finishes: ZN, GRN
- Wt./C 183 Lbs. (83.0 kg)

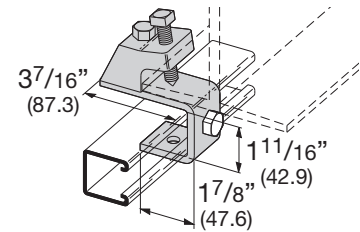

B318 THRU B320 BEAM CLAMP ASSEMBLY

- Safety Factor of 5
- 7/8" (22.2) Max. Flange Thickness
- Includes:
 - 1 pc. B333 Slotted U-Support
 - 2 pcs. B213 I-Beam Clamp
 - 2 pcs. 1/2"-13 x 2 1/2" HHCS
 - 2 pcs. 1/2"-13 Hex Nuts
- Material: Malleable iron
- Standard finishes: ZN, GRN

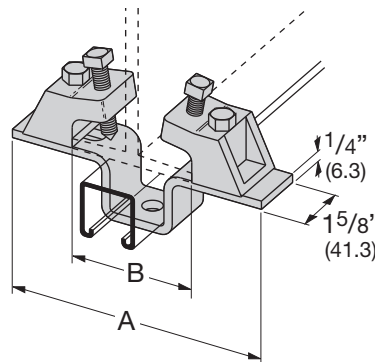

Part No.	A		For Flange Width B		Design Load		Wt./C	
	Lbs.	mm	Lbs.	mm	Lbs.	kN	Lbs.	kg
B318	7 1/4"	(184.1)	2 3/8"-4 1/2"	(60.3-114.3)	1200	(5.34)	325	(147.4)
B319	8 1/2"	(215.9)	3 3/4"-5 3/4"	(95.2-146.0)	800	(3.56)	340	(154.2)
B320	10 3/8"	(263.5)	5 5/8"-7 5/8"	(142.9-193.7)	560	(2.49)	357	(161.9)

B602A THRU B602C BEAM CLAMP WITH GUSSET ASSEMBLY

- Safety Factor of 5
- 7/8" (22.2) Max. Flange Thickness
- Includes:
 - 1 pc. B451 Slotted Three Hole U Support with Gusset
 - 2 pcs. B213 I-Beam Clamp
 - 2 pcs. 1/2"-13 x 2 1/2" HHCS
 - 2 pcs. 1/2"-13 Hex Nuts
- Material: Malleable iron
- Standard finishes: ZN, GRN

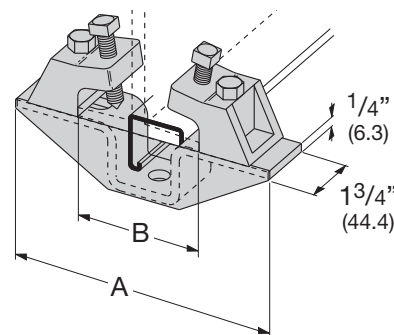

Part No.	A		For Flange Width B		Design Load		Wt./C	
	Lbs.	mm	Lbs.	mm	Lbs.	kN	Lbs.	kg
B602A	7 1/4"	(184.1)	2 3/8"-4 1/2"	(60.3-114.3)	1200	(5.34)	365	(165.1)
B602B	8 1/2"	(215.9)	3 3/4"-5 3/4"	(95.2-146.0)	1200	(5.34)	383	(173.7)
B602C	10 3/8"	(263.5)	5 5/8"-7 5/8"	(142.9-193.7)	1200	(5.34)	408	(185.0)

Reference page 112 for general fitting and standard finish specifications.

Beam Clamps

B760-22 SERIES BEAM CLAMP

- 1" (25.4) Max. Flange Thickness
- For use with 1³/₁₆" (20.6) to 1⁵/₈" (41.3) high channel
- Recommended Torques:
U-Bolt Nuts 150 in-lbs. (16.9 N•m)
J-Hook Nut 60 in-lbs. (6.8 N•m)
- Includes:
1 pc. B760 Plate
1 pc. B701 Type J-Hook only
1 pc. B500-3³/₈" U-Bolt only
3 pcs. 3/8"-16 Hex Nuts
- Standard finish: ZN

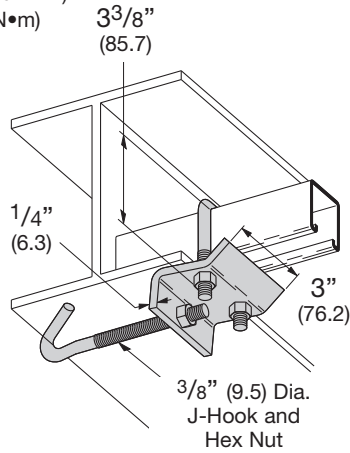

Part No.	For Flange Width		Wt./C	
	Lbs.	kg	Lbs.	kg
B760-22-J4	4"-5 ⁷ / ₈ "	(101.6-149.2)	122	(55.3)
B760-22-J6	6"-8 ⁷ / ₈ "	(152.4-225.4)	129	(58.5)
B760-22-J9	9"-11 ⁷ / ₈ "	(228.6-301.6)	135	(61.2)
B760-22-J12	12"-14 ⁷ / ₈ "	(304.8-377.8)	141	(63.9)

B760-22A SERIES BEAM CLAMP

- 1" (25.4) Max. Flange Thickness
- For use with 1⁵/₈" (41.3) to 3¹/₄" (82.5) high channel
- Recommended Torques:
U-Bolt Nuts 150 in-lbs. (16.9 N•m)
J-Hook Nut 60 in-lbs. (6.8 N•m)
- Includes:
1 pc. B760 Plate
1 pc. B701 Type J-Hook only
1 pc. B500-5" U-Bolt only
3 pcs. 3/8"-16 Hex Nuts
- Standard finish: ZN

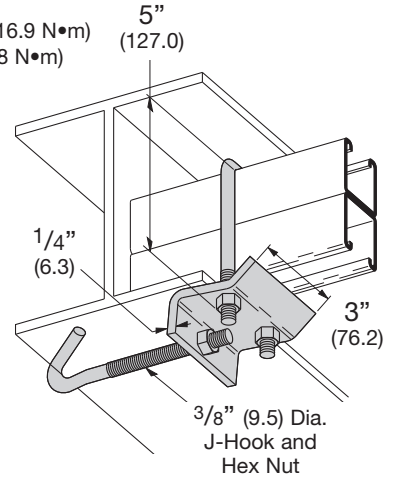

Part No.	For Flange Width		Wt./C	
	Lbs.	kg	Lbs.	kg
B760-22A-J4	4"-5 ⁷ / ₈ "	(101.6-149.2)	129	(58.5)
B760-22A-J6	6"-8 ⁷ / ₈ "	(152.4-225.4)	136	(61.7)
B760-22A-J9	9"-11 ⁷ / ₈ "	(228.6-301.6)	142	(64.4)
B760-22A-J12	12"-14 ⁷ / ₈ "	(304.8-377.8)	148	(67.1)

B761-22 SERIES BEAM CLAMP

- 1" (25.4) Max. Flange Thickness
- For use with 1³/₁₆" (20.6) to 1⁵/₈" (41.3) high channel
- Recommended Torques:
U-Bolt Nuts 150 in-lbs. (16.9 N•m)
ATR Nuts 60 in-lbs. (6.8 N•m)
- Includes:
2 pcs. B700 Plates
2 pcs. B500-3³/₈" U-Bolts only
1 pc. 3/8"-16 ATR (Length)
6 pcs. 3/8"-16 Hex Nuts
- Standard finish: ZN

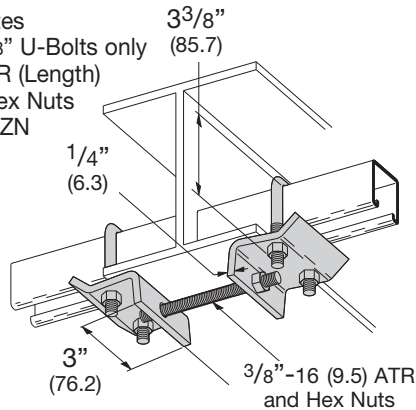

Part No.	For Flange Width		ATR Length	Wt./C	
	Lbs.	kg		Lbs.	kg
B761-22-4	4"-5 ⁷ / ₈ "	(101.6-149.2)	4"	(101.6)	202 (91.6)
B761-22-6	6"-8 ⁷ / ₈ "	(152.4-225.4)	6"	(152.4)	206 (93.4)
B761-22-9	9"-11 ⁷ / ₈ "	(228.6-301.6)	9"	(228.6)	214 (97.0)
B761-22-12	12"-14 ⁷ / ₈ "	(304.8-377.8)	12"	(304.8)	221 (100.2)

B761-22A SERIES BEAM CLAMP

- 1" (25.4) Max. Flange Thickness
- For use with 1⁵/₈" (41.3) to 3¹/₄" (82.5) high channel
- Recommended Torques:
U-Bolt Nuts 150 in-lbs. (16.9 N•m)
ATR Nuts 60 in-lbs. (6.8 N•m)
- Includes:
2 pcs. B700 Plates
2 pcs. B500-5" U-Bolts only
1 pc. 3/8"-16 ATR (Length)
6 pcs. 3/8"-16 Hex Nuts
- Standard finish: ZN

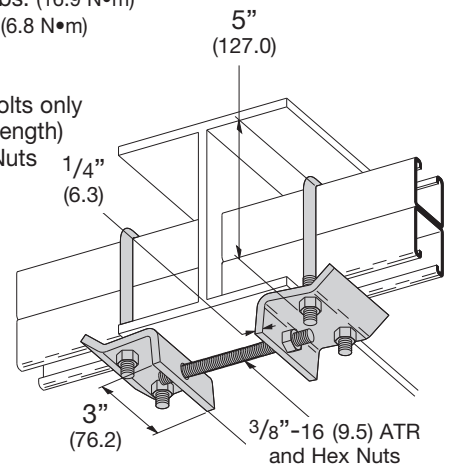

Part No.	For Flange Width		ATR Length	Wt./C	
	Lbs.	kg		Lbs.	kg
B761-22A-4	4"-5 ⁷ / ₈ "	(101.6-149.2)	4"	(101.6)	216 (98.0)
B761-22A-6	6"-8 ⁷ / ₈ "	(152.4-225.4)	6"	(152.4)	220 (99.8)
B761-22A-9	9"-11 ⁷ / ₈ "	(228.6-301.6)	9"	(228.6)	228 (103.4)
B761-22A-12	12"-14 ⁷ / ₈ "	(304.8-377.8)	12"	(304.8)	235 (106.6)

Reference page 112 for general fitting and standard finish specifications.

B614 COLUMN SUPPORT FOR B22

- Quick installation (one bolt to tighten)
- Design Load 800 Lbs. (3.56 kN) Slip with Safety Factor of 3
- Use with B22 and B24 Channel
- Sold in pairs
- Standard finish: ZN
- Wt./C 50 Lbs. (22.6 kg)

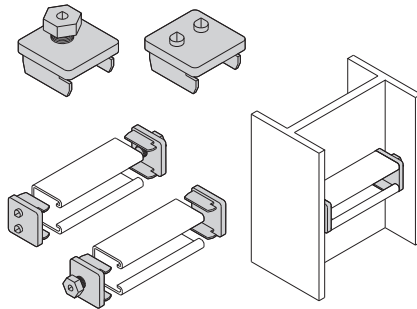

B613 COLUMN SUPPORT FOR B22

- Design Load 800 Lbs. (3.56 kN) Slip with Safety Factor of 3
- Use with B22 and B24 Channel
- Setscrews to be torqued to 19 ft./Lbs
- Sold in pairs
- Standard finishes: ZN, GRN, HDG
- Wt./C 100 Lbs. (45.3 kg)

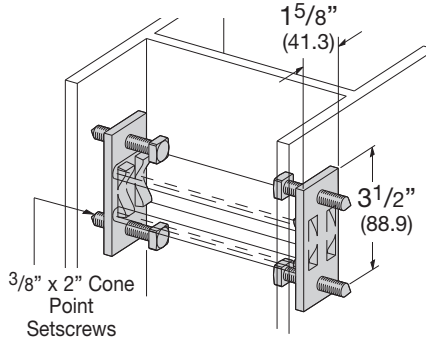

B613A COLUMN SUPPORT FOR B52

- Design Load 800 Lbs. (3.56 kN) Slip with Safety Factor of 3
- Use with B52 and B54 Channel
- Setscrews to be torqued to 19 ft./Lbs
- Sold in pairs
- Standard finishes: ZN, GRN, HDG
- Wt./C 100 Lbs. (45.3 kg)

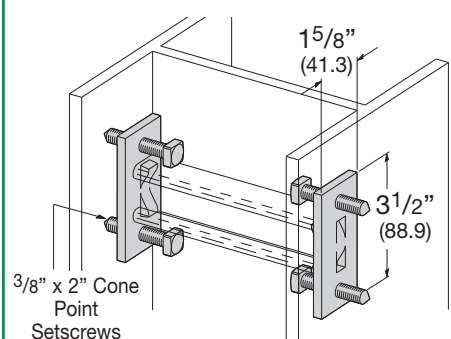

B422 SERIES RIGHT ANGLE CLAMP

- Safety Factor of 5
- Material: 7 Gauge (4.5)
- Standard finishes: ZN, SS4

Part No.	Conduit Size		A	Design Load Vertical Pull		Wt./C	
	Size	(mm)		Lbs.	kg	Lbs.	kg
B422-1/2	1/2"	(15)	2 ³ / ₈ "	(60.3)	250	(1.11)	38 (17.2)
B422-3/4	3/4"	(20)	2 ³ / ₈ "	(60.3)	300	(1.33)	39 (17.7)
B422-1	1"	(25)	2 ⁷ / ₈ "	(73.0)	400	(1.78)	48 (21.8)
B422-1 ¹ / ₄	1 ¹ / ₄ "	(32)	2 ⁷ / ₈ "	(73.0)	400	(1.78)	50 (22.7)
B422-1 ¹ / ₂	1 ¹ / ₂ "	(40)	3 ¹ / ₄ "	(82.5)	500	(2.22)	59 (26.7)
B422-2	2"	(50)	3 ¹¹ / ₁₆ "	(93.7)	600	(2.67)	75 (34.0)
B422-2 ¹ / ₂	2 ¹ / ₂ "	(65)	4 ¹ / ₄ "	(107.9)	700	(3.11)	98 (44.4)
B422-3	3"	(80)	4 ⁷ / ₈ "	(123.8)	800	(3.56)	111 (50.3)
B422-3 ¹ / ₂	3 ¹ / ₂ "	(90)	5 ⁷ / ₁₆ "	(138.1)	900	(4.00)	123 (55.8)
B422-4	4"	(100)	6"	(152.4)	1000	(4.45)	135 (61.2)

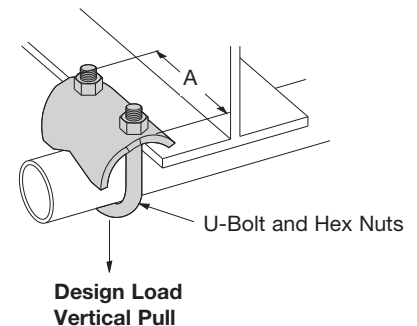

B107S U-SUPPORT

- Material: 7 Gauge (4.5)
- Standard finishes: ZN, GRN
- Wt./C 51 Lbs. (23.1 kg)

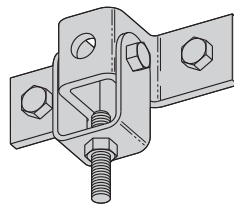
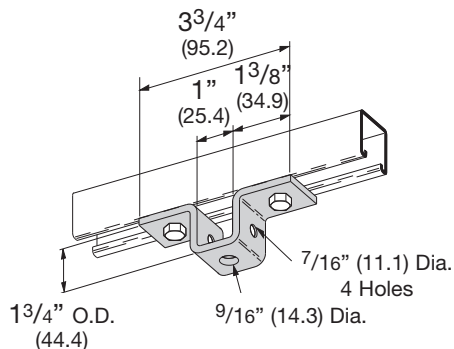

- Illustration shows B107S and B593 used together
- Design Load 900 Lbs., strength of assembly only
- Verify anchorage

B593 CLEVIS SWIVEL

- Includes:
 - 1 pc. 3/8"-16 x 2" HHCS
 - 1 pc. 3/8"-16 Hex Nut
- Material: 11 Gauge (3.0)
- Standard finishes: ZN, GRN
- Wt./C 31 Lbs. (14.0 kg)

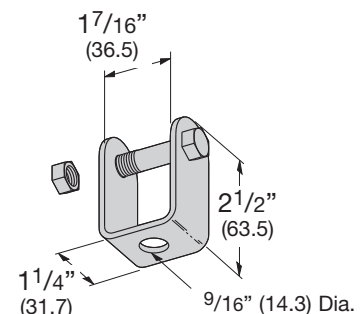

Reference page 112 for general fitting and standard finish specifications.

Pipe/Conduit Clamps & Hangers

Our beam attachments and pipe supports offered in this section are designed to provide supports without drilling or welding. A complete selection of beam clamps, pipe clamps, rollers, supports and accessories are designed for use with our channels and offer many installation advantages.

Materials & Finishes*

Pipe clamps, pipe hangers, beam clamps, brackets, and rollers are made from low carbon steel strips, plates or rod unless noted.

Finish Code	Finish	Specification
PLN	Plain	ASTM A1011 33,000 PSI min. yield
ZN	Electro-Plated Zinc	ASTM B633 SC3 Type III or ASTM A653
GRN	DURA-GREEN™	
DCU	DURA-COPPER™	
HDG	Hot-Dipped Galvanized	ASTM A123
YZN	Yellow Zinc Chromate	ASTM B633 SC3 Type II
SS4	Stainless Steel Type 304	ASTM A240
SS6	Stainless Steel Type 316	ASTM A240
AL	Aluminum	ASTM B209

*Unless otherwise noted.

Load Data

The load data published includes a safety factor of 5.0 unless noted (safety factor = ratio of ultimate load to the design load).

Recommended Torque For Setscrews (unless noted)

Setscrew Size	1/4"-20	3/8"-16	1/2"-13
Foot/Lbs.	4	5	11
Nm	5	7	15

Setscrew Size	5/8"-11	3/4"-10
Foot/Lbs.	21	34
Nm	28	46

*See chart on page 72 for bolt torque.

Metric

Metric dimensions are shown in parentheses. Unless noted, all metric dimensions are in millimeters.



B2207 THRU B2213 MULTI-GRIP PIPE CLAMPS FOR THINWALL (EMT), I.M.C., RIGID CONDUIT OR PIPE

- Safety Factor of 5
- Add PA to suffix for pre-assembled pipe clamps
- Includes Combination Recess Hex Head Machine Screw and Square Nut
- Material: ASTM A1011 33,000 PSI min. yield
- Standard finish: ZN

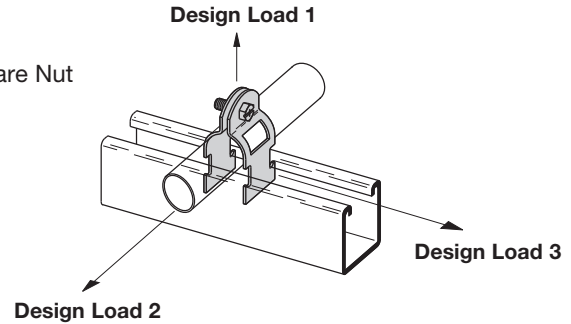

Part No.	Nominal Size		Material Thickness		O.D. Size Range		Alternate For Clamp No.'s	Design Load 1		Design Load 2		Design Load 3		Wt./C	
								Lbs.	kN	Lbs.	kg	Lbs.	kg	Lbs.	kg
B2207	3/8"	(10)	16 Ga.	(1.5)	.557-.706	(14.2-17.9)	B2000, B2001, B2026	400	(1.78)	50	(.22)	50	(.22)	9	(4.1)
B2208	1/2"	(15)	16 Ga.	(1.5)	.701-.875	(17.8-22.2)	B2001, B2008, B2027, B2028	400	(1.78)	50	(.22)	50	(.22)	11	(5.0)
B2209	3/4"	(20)	14 Ga.	(1.9)	.917-1.081	(23.2-27.4)	B2002, B2009,	400	(1.78)	50	(.22)	50	(.22)	12	(5.4)
B2210	1"	(25)	14 Ga.	(1.9)	1.125-1.375	(28.6-34.9)	B2003, B2010, B2030, B2031,	400	(1.78)	50	(.22)	50	(.22)	13	(5.9)
B2211	1 1/4"	(32)	14 Ga.	(1.9)	1.500-1.691	(38.1-42.9)	B2004, B2011, B2033, B2034	400	(1.78)	50	(.22)	50	(.22)	15	(6.8)
B2212	1 1/2"	(40)	12 Ga.	(2.6)	1.735-1.931	(44.0-49.0)	B2005, B2012, B2035	600	(2.67)	75	(.33)	75	(.33)	23	(10.4)
B2213	2"	(50)	12 Ga.	(2.6)	2.192-2.400	(55.7-60.9)	B2006, B2013 B2039	600	(2.67)	75	(.33)	75	(.33)	26	(11.8)

Pipe/Conduit Clamps & Hangers

BPC-8 THRU BPC-64 BREAK-APART CONDUIT CLAMP

- Design Load 200 Lbs. (.896 kN)
- Includes Combination Recess Hex Head Machine Screw
- Material: ASTM A1011 33,000 PSI min. yield
- Standard finish: ZN

Part No.	A Rigid or EMT Conduit Size		Wt./C	
			Lbs.	kg
BPC-8	1/2"	(21.3)	11.2	(5.1)
BPC-12	3/4"	(26.7)	12.7	(5.8)
BPC-16	1"	(33.4)	14.5	(6.6)
BPC-20	1 1/4"	(42.2)	16.5	(7.5)
BPC-24	1 1/2"	(48.3)	18.5	(8.4)
BPC-32	2"	(60.3)	21.5	(9.8)
BPC-40	2 1/2"	(73.0)	21.5	(9.8)
BPC-48	3"	(88.9)	22.0	(10.0)
BPC-56	3 1/2"	(101.6)	23.0	(10.4)
BPC-64	4"	(114.3)	27.5	(12.5)

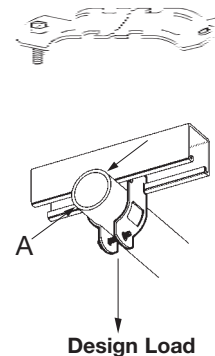

Reference page 126 for general fitting and standard finish specifications.

Pipe Clamps

B2000 SERIES PIPE AND CONDUIT CLAMPS

- Safety Factor of 5
- Add PA to suffix for pre-assembled pipe clamps
- Includes Combination Recess Hex Head Machine Screw and Square Nut
- Material: 16 Ga. (1.5), 14 Ga. (1.9), 12 Ga. (2.6) ASTM A1011 33,000 PSI min. yield and 11 Ga. (3.0) ASTM A1011HSLA Gr. 50
- Standard finishes: ZN, HDG, SS4, SS6, AL

Note: For EMT sizes 2¹/₂" and larger use rigid conduit sizes.

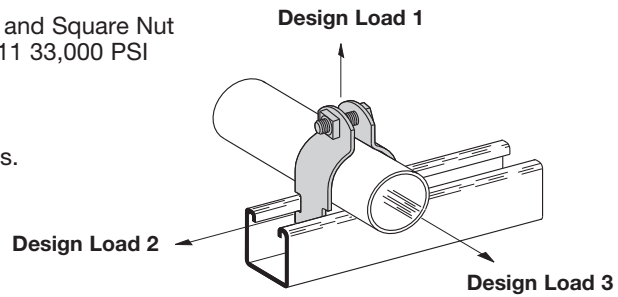

THINWALL CONDUIT (EMT) CLAMPS

Part No.	Conduit Size		Material Thickness		Design Load 1		Design Load 2		Design Load 3		Wt./C	
					Lbs.	kN	Lbs.	kg	Lbs.	kg	Lbs.	kg
B2000	3/8"	(10)	16 Ga.	(1.5)	400	(1.78)	50	(.22)	50	(.22)	10	(4.5)
B2001	1/2"	(15)	16 Ga.	(1.5)	400	(1.78)	50	(.22)	50	(.22)	10	(4.5)
B2002	3/4"	(20)	16 Ga.	(1.9)	400	(1.78)	50	(.22)	50	(.22)	11	(5.0)
B2003	1"	(25)	14 Ga.	(1.9)	600	(2.67)	75	(.33)	75	(.33)	16	(7.2)
B2004	1 1/4"	(32)	14 Ga.	(1.9)	600	(2.67)	75	(.33)	75	(.33)	19	(8.6)
B2005	1 1/2"	(40)	12 Ga.	(2.6)	800	(3.56)	125	(.56)	125	(.56)	28	(12.7)
B2006	2"	(50)	12 Ga.	(2.6)	800	(3.56)	125	(.56)	125	(.56)	33	(14.9)

RIGID CONDUIT OR PIPE CLAMPS

Part No.	Conduit Size		Material Thickness		Design Load 1		Design Load 2		Design Load 3		Wt./C	
					Lbs.	kN	Lbs.	kg	Lbs.	kg	Lbs.	kg
B2001	3/8"	(10)	16 Ga.	(1.5)	400	(1.78)	50	(.22)	50	(.22)	10	(4.5)
B2008	1/2"	(15)	16 Ga.	(1.5)	400	(1.78)	50	(.22)	50	(.22)	11	(5.0)
B2009	3/4"	(20)	14 Ga.	(1.9)	600	(2.67)	75	(.33)	75	(.33)	15	(6.8)
B2010	1"	(25)	14 Ga.	(1.9)	600	(2.67)	75	(.33)	75	(.33)	16	(7.2)
B2011	1 1/4"	(32)	14 Ga.	(1.9)	600	(2.67)	75	(.33)	75	(.33)	20	(9.1)
B2012	1 1/2"	(40)	12 Ga.	(2.6)	800	(3.56)	125	(.56)	125	(.56)	30	(13.6)
B2013	2"	(50)	12 Ga.	(2.6)	800	(3.56)	125	(.56)	125	(.56)	34	(15.4)
B2014	2 1/2"	(65)	12 Ga.	(2.6)	800	(3.56)	125	(.56)	125	(.56)	38	(17.2)
B2015	3"	(80)	12 Ga.	(2.6)	800	(3.56)	125	(.56)	125	(.56)	44	(19.9)
B2016	3 1/2"	(90)	11 Ga.	(3.0)	1000	(4.45)	200	(.89)	150	(.67)	61	(27.6)
B2017	4"	(100)	11 Ga.	(3.0)	1000	(4.45)	200	(.89)	150	(.67)	66	(29.9)
B2018	4 1/2"	(115)	11 Ga.	(3.0)	1000	(4.45)	200	(.89)	150	(.67)	70	(31.7)
B2019	5"	(125)	11 Ga.	(3.0)	1000	(4.45)	200	(.89)	150	(.67)	77	(34.9)
B2020	6"	(150)	11 Ga.	(3.0)	1000	(4.45)	200	(.89)	150	(.67)	100	(45.3)
B2021	7"	(175)	11 Ga.	(3.0)	1000	(4.45)	250	(1.11)	200	(.89)	115	(52.1)
B2022	8"	(200)	11 Ga.	(3.0)	1000	(4.45)	250	(1.11)	200	(.89)	128	(58.0)
B2130	10"	(254)	11 Ga.	(3.0)	1000	(4.45)	250	(1.11)	200	(.89)	160	(72.6)
B2132	12"	(305)	11 Ga.	(3.0)	1000	(4.45)	250	(1.11)	200	(.89)	185	(83.9)

Reference page 126 for general fitting and standard finish specifications.

B2000 SERIES PVC CLAMPS

- Safety Factor of 5
- Add PA to suffix for pre-assembled pipe clamps
- Includes Combination Recess Hex Head Machine Screw and Square Nut
- Material: 16 Ga. (1.5), 14 Ga. (1.9), 12 Ga. (2.6) ASTM A1011 33,000 PSI min. yield and 11 Ga. (3.0) ASTM A1011HSLA Gr. 50
- Standard finishes: PVC

CLAMP SIZING CHART FOR PVC COATED RIGID CONDUIT AND CLAMPS

Nominal Conduit Size		Conduit Coating			
		.020 (.51mm)		.040 (1.01mm)	
		Clamp Coating 0	.020 (.51mm)	Clamp Coating 0	.020 (.51mm)
1/2"	(15)	B2008	B2002	B2002	B2009
3/4"	(20)	B2030	B2030	B2030	B2003
1"	(25)	B2032	B2010	B2010	B2004
1 1/4"	(32)	B2005	B2005	B2005	B2005
1 1/2"	(40)	B2012	B2037	B2037	B2037
2"	(50)	B2013	B2041	B2041	B2041
2 1/2"	(65)	B2014	B2045	B2045	B2045
3"	(80)	B2015	B2050	B2050	B2050
3 1/2"	(90)	B2016	B2054	B2054	B2054
4"	(100)	B2017	B2058	B2058	B2058
5"	(125)	B2019	B2066	B2066	B2066
6"	(150)	B2020	B2115	B2115	B2115

*See B2000 O.D. pipe and conduit clamp chart on pgs. 130-131 for corresponding clamp load data.

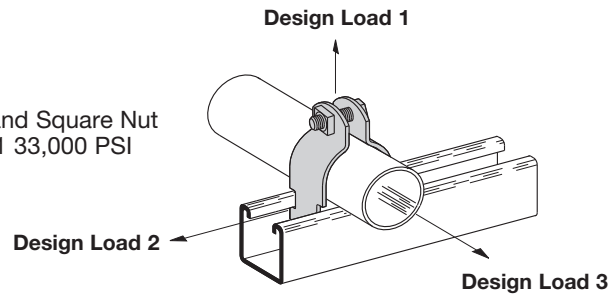

CLAMP SIZING CHART FOR PVC COATED THINWALL (EMT) CONDUIT AND CLAMPS

Nominal Conduit Size		Conduit Coating			
		.020 (.51mm)		.040 (1.01mm)	
		Clamp Coating 0	.020 (.51mm)	Clamp Coating 0	.020 (.51mm)
3/8"	(10)	B2026	B2026	B2026	B2001
1/2"	(15)	B2027	B2027	B2027	B2008
3/4"	(20)	B2009	B2009	B2009	B2009
1"	(25)	B2003	B2031	B2031	B2031
1 1/4"	(32)	B2004	B2011	B2011	B2011
1 1/2"	(40)	B2005	B2005	B2005	B2012
2"	(50)	B2039	B2039	B2039	B2013

*See B2000 O.D. pipe and conduit clamp chart on pgs. 130-131 for corresponding clamp load data.

B2000 SERIES COPPER TUBING CLAMPS

- Safety Factor of 5
- Add PA to suffix for pre-assembled pipe clamps
- Includes Combination Recess Hex Head Machine Screw and Square Nut
- Material: 16 Ga. (1.5), 14 Ga. (1.9), 12 Ga. (2.6) ASTM A1011 33,000 PSI min. yield and 11 Ga. (3.0) ASTM A1011HSLA Gr. 50
- Standard finish: Exclusive DURA-COPPER™ Finish (DCU)

COPPER TUBING CLAMPS

Part No.	Tubing Size	O.D. Size In. (mm)	Material Thickness	Design Load 1		Design Load 2		Design Load 3		Wt./C	
				Lbs.	kN	Lbs.	kg	Lbs.	kg	Lbs.	kg
B2024DCU	1/4"	.375 (9.5)	16 Ga. (1.5)	400	(1.78)	50	(.22)	50	(.22)	8	(3.6)
B2025DCU	3/8"	.500 (12.7)	16 Ga. (1.5)	400	(1.78)	50	(.22)	50	(.22)	9	(4.1)
B2026DCU	1/2"	.625 (15.9)	16 Ga. (1.5)	400	(1.78)	50	(.22)	50	(.22)	10	(4.5)
B2027DCU	5/8"	.750 (19.0)	16 Ga. (1.5)	400	(1.78)	50	(.22)	50	(.22)	10	(4.5)
B2008DCU	3/4"	.875 (22.2)	16 Ga. (1.5)	400	(1.78)	50	(.22)	50	(.22)	11	(5.0)
B2030DCU	1"	1.125 (28.6)	14 Ga. (1.9)	600	(2.67)	75	(.33)	75	(.33)	15	(6.8)
B2010DCU	1 1/4"	1.375 (34.9)	14 Ga. (1.9)	600	(2.67)	75	(.33)	75	(.33)	17	(7.7)
B2011DCU	1 1/2"	1.625 (41.3)	14 Ga. (1.9)	600	(2.67)	75	(.33)	75	(.33)	19	(8.6)
B2038DCU	2	2.125 (54.0)	12 Ga. (2.6)	800	(3.56)	125	(.56)	125	(.56)	32	(14.5)
B2042DCU	2 1/2"	2.625 (66.7)	12 Ga. (2.6)	800	(3.56)	125	(.56)	125	(.56)	35	(15.9)
B2046DCU	3	3.125 (79.4)	12 Ga. (2.6)	800	(3.56)	125	(.56)	125	(.56)	39	(17.7)
B2050DCU	3 1/2"	3.625 (92.1)	11 Ga. (3.0)	1000	(4.45)	200	(.89)	150	(.67)	54	(24.5)
B2054DCU	4	4.125 (104.8)	11 Ga. (3.0)	1000	(4.45)	200	(.89)	150	(.67)	61	(27.6)
B2062DCU	5	5.125 (130.2)	11 Ga. (3.0)	1000	(4.45)	200	(.89)	150	(.67)	70	(31.7)
B2110DCU	6	6.125 (155.6)	11 Ga. (3.0)	1000	(4.45)	250	(1.11)	200	(.89)	94	(42.6)
B2126DCU	8	8.125 (206.4)	11 Ga. (3.0)	1000	(4.45)	250	(1.11)	200	(.89)	123	(55.8)

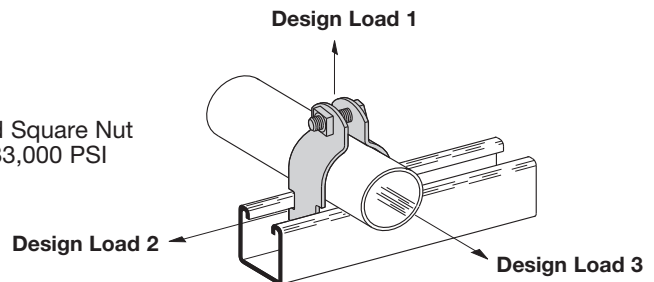

Reference page 126 for general fitting and standard finish specifications.

Pipe Clamps

B2000 SERIES O.D. PIPE AND CONDUIT CLAMPS

- Safety Factor of 5
- Add PA to suffix for pre-assembled pipe clamps
- Other sizes available upon request
- Includes Combination Recess Hex Head Machine Screw and Square Nut.
- Material: 16 Ga. (1.5), 14 Ga. (1.9), 12 Ga. (2.6)
ASTM A1011 33,000 PSI min. yield and 11 Ga. (3.0)
ASTM A1011HSLA Gr. 50
- Standard finishes: ZN, HDG, SS4

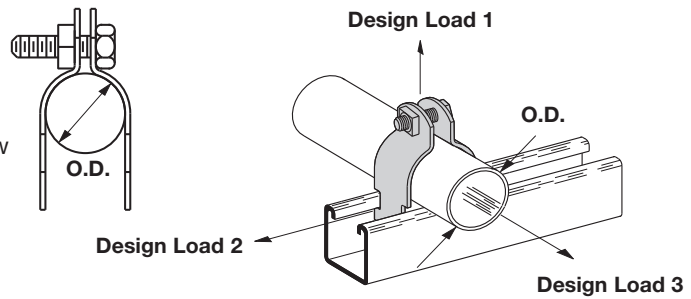

O.D. CLAMPS

Part No.	O.D. Size (in.)		Hardware Size	Material Gauge Thickness		Design Load 1		Design Load 2		Design Load 3		Wt./C	
						Lbs.	kN	Lbs.	kN	Lbs.	kN	Lbs.	kg
B2023	1/4"	(6.3)	1/4"-20	16	(1.5)	120	(.54)	30	(.13)	30	(.13)	8	(3.6)
B2024	3/8"	(9.5)	1/4"-20	16	(1.5)	300	(1.33)	40	(.18)	40	(.18)	8	(3.6)
B2025	1/2"	(12.7)	1/4"-20	16	(1.5)	400	(1.78)	50	(.22)	50	(.22)	9	(4.1)
B2026	5/8"	(15.9)	1/4"-20	16	(1.5)	400	(1.78)	50	(.22)	50	(.22)	10	(4.5)
B2027	3/4"	(19.0)	1/4"-20	16	(1.5)	400	(1.78)	50	(.22)	50	(.22)	10	(4.5)
B2008	7/8"	(22.2)	1/4"-20	16	(1.5)	400	(1.78)	50	(.22)	50	(.22)	11	(5.0)
B2009	1"	(25.4)	1/4"-20	14	(1.9)	500	(2.22)	75	(.33)	75	(.33)	15	(6.8)
B2030	1 1/8"	(28.6)	1/4"-20	14	(1.9)	600	(2.67)	75	(.33)	75	(.33)	15	(6.8)
B2031	1 1/4"	(31.7)	1/4"-20	14	(1.9)	600	(2.67)	75	(.33)	75	(.33)	16	(7.3)
B2010	1 3/8"	(34.9)	1/4"-20	14	(1.9)	600	(2.67)	75	(.33)	75	(.33)	17	(7.7)
B2004	1 1/2"	(38.1)	1/4"-20	14	(1.9)	600	(2.67)	75	(.33)	75	(.33)	18	(8.2)
B2011	1 5/8"	(41.3)	1/4"-20	14	(1.9)	600	(2.67)	75	(.33)	75	(.33)	19	(8.6)
B2005	1 3/4"	(44.4)	5/16"-18	12	(2.6)	800	(3.56)	125	(.56)	125	(.56)	29	(13.1)
B2012	1 7/8"	(47.6)	5/16"-18	12	(2.6)	800	(3.56)	125	(.56)	125	(.56)	30	(13.6)
B2037	2	(50.8)	5/16"-18	12	(2.6)	800	(3.56)	125	(.56)	125	(.56)	30	(13.6)
B2038	2 1/8"	(54.0)	5/16"-18	12	(2.6)	800	(3.56)	125	(.56)	125	(.56)	32	(14.5)
B2039	2 1/4"	(57.1)	5/16"-18	12	(2.6)	800	(3.56)	125	(.56)	125	(.56)	32	(14.5)
B2013	2 3/8"	(60.3)	5/16"-18	12	(2.6)	800	(3.56)	125	(.56)	125	(.56)	34	(15.4)
B2041	2 1/2"	(63.5)	5/16"-18	12	(2.6)	800	(3.56)	125	(.56)	125	(.56)	35	(15.9)
B2042	2 5/8"	(66.7)	5/16"-18	12	(2.6)	800	(3.56)	125	(.56)	125	(.56)	35	(15.9)
B2043	2 3/4"	(69.8)	5/16"-18	12	(2.6)	800	(3.56)	125	(.56)	125	(.56)	38	(17.2)
B2014	2 7/8"	(73.0)	5/16"-18	12	(2.6)	800	(3.56)	125	(.56)	125	(.56)	38	(17.2)
B2045	3	(76.2)	5/16"-18	12	(2.6)	800	(3.56)	125	(.56)	125	(.56)	38	(17.2)
B2046	3 1/8"	(79.4)	5/16"-18	12	(2.6)	800	(3.56)	125	(.56)	125	(.56)	39	(17.7)
B2047	3 1/4"	(82.5)	5/16"-18	12	(2.6)	800	(3.56)	125	(.56)	125	(.56)	41	(18.6)
B2048	3 3/8"	(85.7)	5/16"-18	12	(2.6)	800	(3.56)	125	(.56)	125	(.56)	43	(19.5)
B2015	3 1/2"	(88.9)	5/16"-18	12	(2.6)	800	(3.56)	125	(.56)	125	(.56)	44	(20.0)
B2050	3 5/8"	(92.1)	5/16"-18	11	(3.0)	1000	(4.45)	200	(.89)	150	(.67)	54	(24.5)
B2051	3 3/4"	(95.2)	5/16"-18	11	(3.0)	1000	(4.45)	200	(.89)	150	(.67)	57	(25.8)
B2052	3 7/8"	(98.4)	5/16"-18	11	(3.0)	1000	(4.45)	200	(.89)	150	(.67)	55	(25.0)
B2016	4	(101.6)	5/16"-18	11	(3.0)	1000	(4.45)	200	(.89)	150	(.67)	57	(25.8)
B2054	4 1/8"	(104.8)	5/16"-18	11	(3.0)	1000	(4.45)	200	(.89)	150	(.67)	61	(27.7)
B2055	4 1/4"	(107.9)	5/16"-18	11	(3.0)	1000	(4.45)	200	(.89)	150	(.67)	62	(28.1)
B2056	4 3/8"	(111.1)	5/16"-18	11	(3.0)	1000	(4.45)	200	(.89)	150	(.67)	64	(29.0)
B2017	4 1/2"	(114.3)	5/16"-18	11	(3.0)	1000	(4.45)	200	(.89)	150	(.67)	66	(29.9)
B2058	4 5/8"	(117.5)	5/16"-18	11	(3.0)	1000	(4.45)	200	(.89)	150	(.67)	66	(29.9)

Reference page 126 for general fitting and standard finish specifications.

B2000 SERIES O.D. PIPE AND CONDUIT CLAMPS

- Safety Factor of 5
- Add PA to suffix for pre-assembled pipe clamps
- Other sizes available upon request
- Includes Combination Recess Hex Head Machine Screw and Square Nut.
- Material: 16 Ga. (1.5), 14 Ga. (1.9), 12 Ga. (2.6) ASTM A1011 33,000 PSI min. yield and 11 Ga. (3.0) ASTM A1011HSLA Gr. 50
- Standard finishes: ZN, HDG, SS4

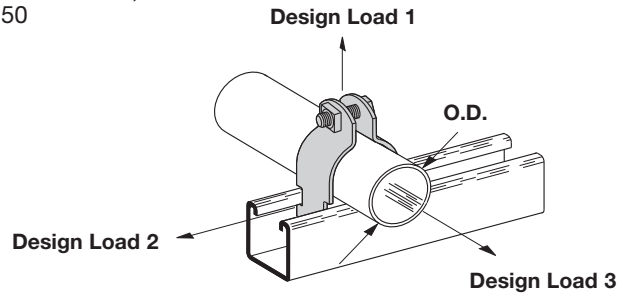

O.D. CLAMPS

Part No.	O.D. Size (in.)		Hardware Size	Material Gauge Thickness		Design Load 1		Design Load 2		Design Load 3		Wt./C	
		(mm)				Lbs.	kN	Lbs.	kN	Lbs.	kN	Lbs.	kg
B2059	4 ³ / ₄ "	(120.6)	5/16"-18	11	(3.0)	1000	(4.45)	200	(.89)	150	(.67)	68	(30.8)
B2060	4 ⁷ / ₈ "	(123.8)	5/16"-18	11	(3.0)	1000	(4.45)	200	(.89)	150	(.67)	69	(31.3)
B2018	5	(127.0)	5/16"-18	11	(3.0)	1000	(4.45)	200	(.89)	150	(.67)	70	(31.8)
B2062	5 ¹ / ₈ "	(130.2)	5/16"-18	11	(3.0)	1000	(4.45)	200	(.89)	150	(.67)	70	(31.8)
B2063	5 ¹ / ₄ "	(133.3)	5/16"-18	11	(3.0)	1000	(4.45)	200	(.89)	150	(.67)	70	(31.8)
B2064	5 ³ / ₈ "	(136.5)	5/16"-18	11	(3.0)	1000	(4.45)	200	(.89)	150	(.67)	77	(34.9)
B2019	5 ¹ / ₂ "	(139.7)	5/16"-18	11	(3.0)	1000	(4.45)	200	(.89)	150	(.67)	78	(35.4)
B2066	5 ⁵ / ₈ "	(142.9)	5/16"-18	11	(3.0)	1000	(4.45)	200	(.89)	150	(.67)	83	(37.6)
B2067	5 ³ / ₄ "	(146.0)	5/16"-18	11	(3.0)	1000	(4.45)	200	(.89)	150	(.67)	84	(38.1)
B2068	5 ⁷ / ₈ "	(149.2)	5/16"-18	11	(3.0)	1000	(4.45)	200	(.89)	150	(.67)	85	(38.6)
B2069	6"	(152.4)	5/16"-18	11	(3.0)	1000	(4.45)	200	(.89)	150	(.67)	87	(39.5)
B2110	6 ¹ / ₈ "	(155.6)	3/8"-16	11	(3.0)	1000	(4.45)	250	(1.11)	200	(.89)	94	(42.6)
B2111	6 ¹ / ₄ "	(158.7)	3/8"-16	11	(3.0)	1000	(4.45)	250	(1.11)	200	(.89)	96	(43.5)
B2112	6 ³ / ₈ "	(161.9)	3/8"-16	11	(3.0)	1000	(4.45)	250	(1.11)	200	(.89)	98	(44.4)
B2113	6 ¹ / ₂ "	(165.1)	3/8"-16	11	(3.0)	1000	(4.45)	250	(1.11)	200	(.89)	99	(44.9)
B2020	6 ⁵ / ₈ "	(168.3)	3/8"-16	11	(3.0)	1000	(4.45)	250	(1.11)	200	(.89)	100	(45.4)
B2115	6 ³ / ₄ "	(171.4)	3/8"-16	11	(3.0)	1000	(4.45)	250	(1.11)	200	(.89)	102	(46.3)
B2116	6 ⁷ / ₈ "	(174.6)	3/8"-16	11	(3.0)	1000	(4.45)	250	(1.11)	200	(.89)	104	(47.2)
B2117	7"	(177.8)	3/8"-16	11	(3.0)	1000	(4.45)	250	(1.11)	200	(.89)	106	(48.1)
B2118	7 ¹ / ₈ "	(181.0)	3/8"-16	11	(3.0)	1000	(4.45)	250	(1.11)	200	(.89)	108	(49.0)
B2119	7 ¹ / ₄ "	(184.1)	3/8"-16	11	(3.0)	1000	(4.45)	250	(1.11)	200	(.89)	110	(49.9)
B2120	7 ³ / ₈ "	(187.3)	3/8"-16	11	(3.0)	1000	(4.45)	250	(1.11)	200	(.89)	112	(50.8)
B2121	7 ¹ / ₂ "	(190.5)	3/8"-16	11	(3.0)	1000	(4.45)	250	(1.11)	200	(.89)	114	(51.7)
B2021	7 ⁵ / ₈ "	(193.7)	3/8"-16	11	(3.0)	1000	(4.45)	250	(1.11)	200	(.89)	115	(52.2)
B2123	7 ³ / ₄ "	(196.8)	3/8"-16	11	(3.0)	1000	(4.45)	250	(1.11)	200	(.89)	117	(53.1)
B2124	7 ⁷ / ₈ "	(200.0)	3/8"-16	11	(3.0)	1000	(4.45)	250	(1.11)	200	(.89)	119	(54.0)
B2125	8"	(203.2)	3/8"-16	11	(3.0)	1000	(4.45)	250	(1.11)	200	(.89)	121	(54.9)
B2126	8 ¹ / ₈ "	(206.4)	3/8"-16	11	(3.0)	1000	(4.45)	250	(1.11)	200	(.89)	123	(55.8)
B2127	8 ¹ / ₄ "	(209.5)	3/8"-16	11	(3.0)	1000	(4.45)	250	(1.11)	200	(.89)	125	(56.7)
B2128	8 ³ / ₈ "	(212.7)	3/8"-16	11	(3.0)	1000	(4.45)	250	(1.11)	200	(.89)	126	(57.2)
B2129	8 ¹ / ₂ "	(215.9)	3/8"-16	11	(3.0)	1000	(4.45)	250	(1.11)	200	(.89)	128	(58.1)
B2022	8 ⁵ / ₈ "	(219.1)	3/8"-16	11	(3.0)	1000	(4.45)	250	(1.11)	200	(.89)	128	(58.1)
B2130	10 ³ / ₄ "	(273.0)	3/8"-16	11	(3.0)	1000	(4.45)	250	(1.11)	200	(.89)	160	(72.6)
B2132	12 ³ / ₄ "	(323.8)	3/8"-16	11	(3.0)	1000	(4.45)	250	(1.11)	200	(.89)	185	(83.9)

Reference page 126 for general fitting and standard finish specifications.

Pipe Clamps

B1508 THRU B1564S CONDUIT/STRUT CLAMPS

- Safety Factor of 3
- Clamps without saddles are not recommended for flexible conduit or cable
- All Sizes Include:
1/4"-20 Slotted Hex Head Machine Screw
- Standard finish: ZN

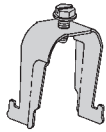
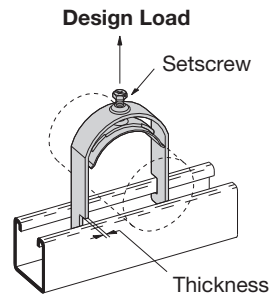

B1508 THRU B1520

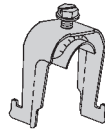

B1508S THRU B1524S

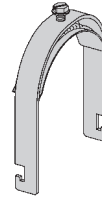

B1532S THRU B1564S

Part No.	Use With				Thickness		Design Load		Wt./C	
	EMT		Rigid Conduit				Lbs.	kN	Lbs.	kg
B1508	1/2"	(15)	-	-	16 Ga.	(1.5)	200	(.89)	7.4	(3.4)
B1512	3/4"	(20)	1/2"	(15)	16 Ga.	(1.5)	200	(.89)	8.0	(3.6)
B1516	1"	(25)	3/4"	(20)	14 Ga.	(1.9)	300	(1.33)	11.0	(5.0)
B1520	1 1/4"	(32)	1"	(25)	14 Ga.	(1.9)	300	(1.33)	12.5	(5.7)
B1508S	1/2"	(15)	-	-	16 Ga.	(1.5)	200	(.89)	8.6	(3.9)
B1512S	3/4"	(20)	1/2"	(15)	16 Ga.	(1.5)	200	(.89)	9.2	(4.2)
B1516S	1"	(25)	3/4"	(20)	14 Ga.	(1.9)	300	(1.33)	12.7	(5.8)
B1520S	1 1/4"	(32)	1"	(25)	14 Ga.	(1.9)	300	(1.33)	14.6	(6.6)
B1524S	1 1/2"	(40)	1 1/4"	(32)	12 Ga.	(2.6)	400	(1.78)	20.5	(9.3)
B1532S	2"	(50)	1 1/2"	(40)	12 Ga.	(2.6)	400	(1.78)	21.5	(9.8)
B1534S	-	-	2"	(50)	12 Ga.	(2.6)	400	(1.78)	22.7	(10.3)
B1540S	2 1/2"	(65)	2 1/2"	(65)	12 Ga.	(2.6)	400	(1.78)	26.0	(11.9)
B1548S	3"	(80)	3"	(80)	12 Ga.	(2.6)	400	(1.78)	30.2	(13.7)
B1556S	3 1/2"	(90)	3 1/2"	(90)	12 Ga.	(2.6)	400	(1.78)	33.3	(15.1)
B1564S	4"	(100)	4"	(100)	12 Ga.	(2.6)	400	(1.78)	36.6	(16.6)

Reference page 126 for general fitting and standard finish specifications.

B2601 THRU B2610 TWIST EAR™ PIPE CLAMP

- One piece break apart, screw retainer, thread impressions
- Tighter alignment, no need to leave additional space between clamps in order to access nut and bolt
- Easier access bolt can be tightened directly from front
- Available in 1/2", 3/4", 1" rigid and EMT Conduit
- Recommended Torque 30 in. - lbs.
- Safety Factor of 3
- Standard finish: ZN

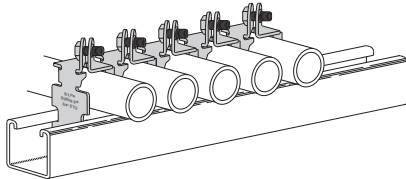

Allows for multiple clamps to be used in succession, with easier access than other pipe clamps.

Design Load

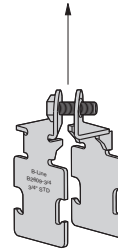

Break-apart - break in the middle, bolt the ends together.

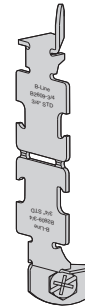

No loose pieces. One piece break apart with screw retainer and thread impressions.

Part No.	Use With		Thickness	Design Load		Wt./C	
	EMT	Rigid Conduit		Lbs.	kN	Lbs.	kg
B2601	1/2" (17.9)	-	16 Ga.	300	(1.34)	8.2	(3.7)
B2602	3/4" (23.4)	-	14 Ga.	500	(2.24)	13.5	(6.1)
B2603	1" (29.5)	-	14 Ga.	500	(2.24)	15.6	(7.1)
B2608	-	1/2" (21.3)	16 Ga.	300	(1.34)	8.2	(3.7)
B2609	-	3/4" (26.7)	14 Ga.	500	(2.24)	13.5	(6.1)
B2610	-	1" (33.4)	14 Ga.	500	(2.24)	15.6	(7.1)

BP081SS THRU BP475SS P CLAMPS

- Minimizes induction heating
- Material: Stainless Steel Type 304

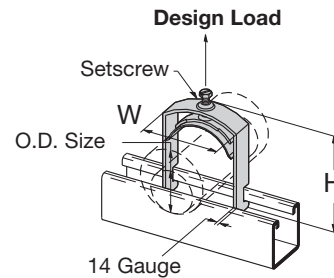

Part No.	O.D. Size		Height H		Width W		Design Load		Wt./C.	
	In.	mm	In.	mm	In.	mm	Lbs.	kN	Lbs.	kg
BP081SS	.250-.840	(6.4-21.3)	1.86	(47.2)	0.87	(22.1)	300	(1.33)	9.0	(4.1)
BP110SS	.810-1.100	(20.6-28.0)	2.18	(55.4)	1.19	(30.2)	300	(1.33)	12.0	(5.4)
BP135SS	.850-1.350	(21.6-34.8)	2.25	(57.2)	1.38	(35.1)	300	(1.33)	14.0	(6.3)
BP175SS	1.250-1.750	(31.8-44.4)	2.78	(70.6)	1.78	(45.2)	300	(1.33)	21.0	(9.5)
BP205SS	1.550-2.050	(39.4-52.1)	3.00	(76.2)	2.28	(57.9)	300	(1.33)	30.0	(13.6)
BP250SS	2.00-2.50	(50.8-63.5)	3.43	(87.1)	2.83	(71.9)	300	(1.33)	35.0	(15.9)
BP300SS	2.55-3.00	(64.7-76.2)	3.87	(97.8)	3.15	(80.0)	300	(1.33)	39.0	(17.7)
BP325SS	2.75-3.25	(69.9-82.8)	4.06	(103.1)	3.28	(83.3)	300	(1.33)	41.0	(18.6)
BP375SS	3.25-3.75	(82.6-95.3)	4.60	(116.8)	3.83	(97.3)	300	(1.33)	47.0	(21.3)
BP425SS	3.75-4.25	(95.3-108.0)	5.13	(130.3)	4.50	(114.3)	300	(1.33)	54.0	(24.4)
BP475SS	4.25-4.75	(108.0-120.7)	5.70	(5.70)	4.85	(123.2)	300	(1.33)	58.0	(26.3)

Reference page 126 for general fitting and standard finish specifications.

VibraClamp™ Pipe Clamps

BVT SERIES VIBRACLAMP - COPPER & O.D.

- Safety Factor of 3
- Accesses tubing sizes 1/8" (3) to 6" (150)
- Allows easy one tool installation
- Endures both high (+300°F) and low (-40°F) temperatures
- Dampens vibration and noise
- Eliminates galvanic metal to metal contact
- Resists most industrial oils and solvents
- Reduces thermal loss and gain
- Secures tubing firmly to channel (strut)
- Dielectric strength of 400 volts/mil
- Includes cushion, clamp, screw and nut
- Standard finishes: YZN, SS4

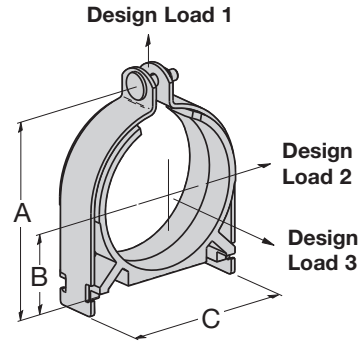

Catalog Number	Tubing O.D. Size		Copper Tubing Size		Dimensions						Wt./C	
					A		B		C		Lbs.	kg
BVT025	1/4"	(6.3)	1/8"	(3)	1.22	(30.9)	0.19	(4.8)	0.49	(12.4)	11	(5.0)
BVT037	3/8"	(9.5)	1/4"	(6)	1.36	(34.5)	0.25	(6.3)	0.61	(15.5)	12	(5.4)
BVT050	1/2"	(12.7)	3/8"	(10)	1.49	(37.8)	0.31	(7.8)	0.74	(18.8)	14	(6.3)
BVT062	5/8"	(15.9)	1/2"	(15)	1.62	(41.1)	0.38	(9.6)	0.86	(21.8)	15	(6.8)
BVT075	3/4"	(19.0)	5/8"	(17)	1.87	(47.4)	0.50	(12.7)	1.15	(29.2)	19	(8.6)
BVT087	7/8"	(22.2)	3/4"	(20)	2.00	(50.8)	0.56	(14.2)	1.27	(32.2)	21	(9.5)
BVT100	1"	(25.4)	-	-	2.25	(57.1)	0.69	(17.5)	1.52	(38.6)	22	(10.0)
BVT112	1 1/8"	(28.6)	1"	(25)	2.25	(57.1)	0.69	(17.5)	1.52	(38.6)	26	(11.8)
BVT125	1 1/4"	(31.7)	-	-	2.51	(63.7)	0.81	(20.6)	1.78	(45.2)	36	(16.3)
BVT137	1 3/8"	(34.9)	1 1/4"	(32)	2.51	(63.7)	0.81	(20.6)	1.78	(45.2)	38	(17.2)
BVT150	1 1/2"	(38.1)	-	-	2.74	(69.6)	0.88	(22.4)	1.96	(49.8)	35	(15.9)
BVT162	1 5/8"	(41.3)	1 1/2"	(40)	3.00	(76.2)	1.00	(25.4)	2.20	(55.9)	40	(18.1)
BVT175	1 3/4"	(44.4)	-	-	3.13	(79.5)	1.06	(26.9)	2.33	(59.1)	44	(19.9)
BVT187	1 7/8"	(47.6)	-	-	3.28	(83.3)	1.13	(28.7)	2.46	(62.5)	40	(18.1)
BVT200	2"	(50.8)	-	-	3.52	(89.4)	1.25	(31.7)	2.70	(68.6)	55	(25.0)
BVT212	2 1/8"	(54.0)	2"	(50)	3.52	(89.4)	1.25	(31.7)	2.70	(68.6)	55	(25.0)
BVT225	2 1/4"	(57.1)	-	-	3.64	(92.4)	1.31	(33.2)	2.83	(71.8)	54	(24.5)
BVT250	2 1/2"	(63.5)	-	-	3.91	(99.3)	1.43	(36.3)	3.11	(79.0)	56	(25.4)
BVT262	2 5/8"	(66.6)	2 1/2"	(65)	4.02	(102.1)	1.50	(38.1)	3.20	(81.3)	55	(25.0)
BVT300	3"	(76.2)	-	-	4.42	(112.2)	1.68	(42.6)	3.61	(91.6)	67	(30.4)
BVT312	3 1/8"	(79.4)	3"	(80)	4.53	(115.0)	1.75	(44.4)	3.70	(93.9)	64	(29.0)
BVT362	3 5/8"	(92.1)	3 1/2"	(90)	5.05	(128.2)	2.00	(50.8)	4.23	(107.4)	76	(34.5)
BVT412	4 1/8"	(104.8)	4"	(100)	5.55	(140.9)	2.25	(57.1)	4.73	(120.1)	93	(42.2)
BVT612	6 1/8"	(155.5)	6"	(150)	7.62	(193.5)	3.25	(82.5)	6.74	(171.1)	136	(61.6)

Catalog Number	Design Load 1		Design Load 2		Design Load 3	
	Lbs.	kN	Lbs.	kN	Lbs.	kN
BVT025	400	(1.78)	50	(0.22)	50	(0.22)
BVT037	400	(1.78)	50	(0.22)	50	(0.22)
BVT050	400	(1.78)	50	(0.22)	50	(0.22)
BVT062	400	(1.78)	50	(0.22)	50	(0.22)
BVT075	600	(2.67)	75	(0.33)	75	(0.33)
BVT087	600	(2.67)	75	(0.33)	75	(0.33)
BVT100	600	(2.67)	75	(0.33)	75	(0.33)
BVT112	600	(2.67)	75	(0.33)	75	(0.33)
BVT125	600	(2.67)	75	(0.33)	75	(0.33)
BVT137	600	(2.67)	75	(0.33)	75	(0.33)
BVT150	600	(2.67)	75	(0.33)	75	(0.33)
BVT162	800	(3.56)	125	(0.56)	125	(0.56)
BVT175	800	(3.56)	125	(0.56)	125	(0.56)
BVT187	800	(3.56)	125	(0.56)	125	(0.56)
BVT200	800	(3.56)	125	(0.56)	125	(0.56)
BVT212	800	(3.56)	125	(0.56)	125	(0.56)
BVT225	800	(3.56)	125	(0.56)	125	(0.56)
BVT250	800	(3.56)	125	(0.56)	125	(0.56)
BVT262	800	(3.56)	125	(0.56)	125	(0.56)
BVT300	800	(3.56)	125	(0.56)	125	(0.56)
BVT312	800	(3.56)	125	(0.56)	125	(0.56)
BVT362	1000	(4.45)	200	(0.89)	150	(0.67)
BVT412	1000	(4.45)	200	(0.89)	150	(0.67)
BVT612	1000	(4.45)	200	(0.89)	150	(0.67)

Reference page 126 for general fitting and standard finish specifications.

Pipe/Conduit Clamps & Hangers

BVP SERIES VIBRACLAMP - IRON PIPE & RIGID CONDUIT

- Safety Factor of 3
- Accesses pipe sizes 1/4" (6) to 6" (150)
- Allows easy one tool installation
- Endures both high (+300°F) and low (-40°F) temperatures
- Dampens vibration and noise
- Eliminates galvanic metal to metal contact
- Resists most industrial oils and solvents
- Reduces thermal loss and gain
- Secures pipe firmly to channel (strut)
- Dielectric strength of 400 volts/mil
- Includes cushion, clamp, screw and nut
- Standard finishes: YZN, SS4

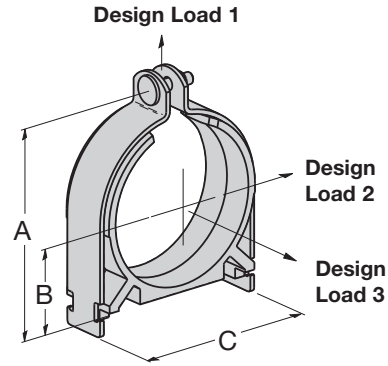

Catalog Number	Nominal Pipe Size		Steel O.D. Size		Dimensions						Wt./C	
					A		B		C		Lbs.	kg
BVP025	1/4"	(6.3)	0.540	(13.7)	1.61	(39.9)	0.37	(9.4)	0.87	(22.1)	15	(6.8)
BVP037	3/8"	(9.5)	0.675	(17.1)	1.86	(47.2)	0.50	(12.7)	1.15	(29.2)	18	(8.2)
BVP050	1/2"	(12.7)	0.875	(22.2)	1.99	(50.5)	0.56	(14.2)	1.27	(32.3)	20	(9.1)
BVP075	3/4"	(19.0)	1.050	(26.7)	2.25	(57.1)	0.69	(17.5)	1.52	(38.6)	21	(9.5)
BVP100	1"	(25.4)	1.312	(33.3)	2.51	(63.8)	0.81	(20.6)	1.77	(45.0)	20	(9.1)
BVP125	1 1/4"	(31.7)	1.660	(42.2)	3.00	(76.2)	1.00	(25.4)	2.21	(56.1)	36	(16.3)
BVP150	1 1/2"	(38.1)	1.900	(48.3)	3.21	(83.1)	1.12	(28.4)	2.41	(62.3)	40	(18.1)
BVP200	2"	(50.8)	2.375	(60.3)	3.77	(95.8)	1.37	(34.8)	2.96	(75.2)	45	(20.4)
BVP250	2 1/2"	(63.5)	2.875	(73.0)	4.28	(108.7)	1.62	(41.1)	3.46	(87.9)	54	(24.5)
BVP300	3"	(76.2)	3.500	(88.9)	5.05	(128.3)	2.00	(50.8)	4.24	(107.7)	81	(36.7)
BVP350	3 1/2"	(88.9)	4.000	(101.6)	5.55	(140.9)	2.25	(57.1)	4.74	(120.3)	87	(39.4)
BVP400	4"	(101.6)	4.500	(114.3)	6.05	(153.7)	2.50	(63.5)	5.24	(133.1)	109	(49.4)
BVP500	5"	(127.0)	5.563	(141.3)	6.84	(173.7)	3.00	(76.2)	6.24	(158.4)	136	(61.6)
BVP600	6"	(152.4)	6.625	(168.3)	8.24	(209.3)	3.56	(90.4)	7.36	(186.9)	163	(73.8)

Catalog Number	Design Load 1		Design Load 2		Design Load 3	
	Lbs.	kN	Lbs.	kN	Lbs.	kN
BVP025	400	(1.78)	50	(0.22)	50	(0.22)
BVP037	600	(2.67)	75	(0.33)	75	(0.33)
BVP050	600	(2.67)	75	(0.33)	75	(0.33)
BVP075	600	(2.67)	75	(0.33)	75	(0.33)
BVP100	600	(2.67)	75	(0.33)	75	(0.33)
BVP125	800	(3.56)	125	(0.56)	125	(0.56)
BVP150	800	(3.56)	125	(0.56)	125	(0.56)
BVP200	800	(3.56)	125	(0.56)	125	(0.56)
BVP250	800	(3.56)	125	(0.56)	125	(0.56)
BVP300	1000	(4.45)	200	(0.89)	150	(0.67)
BVP350	1000	(4.45)	200	(0.89)	150	(0.67)
BVP400	1000	(4.45)	200	(0.89)	150	(0.67)
BVP500	1000	(4.45)	200	(0.89)	150	(0.67)
BVP600	1000	(4.45)	200	(0.89)	150	(0.67)

Reference page 126 for general fitting and standard finish specifications.

Armafix™ Clamps & Accessories

IPH SERIES INSERTS - INSERTS WITH CLAMPS

- Engineered load-bearing inserts prevents insulation compression
- Innovative insulated pipe support
- Desirable “Foam-to-Foam” Bond
- Slip Data: 45 lbs. (0.20 kN) max
- Recommended Clamp Torque: 12-15 in.-lbs. (1.3-1.7 Nm)
- Service Temperature Range
-58°F (-50°C) to +220°F (+105°C)



Insert Only



Assembly
Insert & Clamp

3/4" Wall Insulation Thickness

Assembly Part No.	Insert Only Part No.	Pipe/Copper/OD Size	Hanger Size*
IPH03834	IPH03834WO	3/8" O.D.	2"
IPH01234	IPH01234WO	1/2" O.D.	2"
IPH05834	IPH05834WO	5/8" O.D.	2"
IPH07834	IPH07834WO	7/8" O.D.	2 1/2"
IPH11834	IPH11834WO	3/4" IPS & 1 1/8" O.D.	2 1/2"
IPH13834	IPH13834WO	1 3/8" O.D.	3"
IPH15834	IPH15834WO	1 5/8" O.D.	3 1/2"
IPH11034	IPH11034WO	1 1/2" IPS & 1 7/8" O.D.	3 1/2"
IPH21834	IPH21834WO	2 1/8" O.D.	4"
IPH25834	IPH25834WO	2 5/8" O.D.	5"
IPH31834	IPH31834WO	3 1/8" O.D.	5"
IPH35834	IPH35834WO	3 5/8" O.D.	6"
IPH41834	IPH41834WO	4 1/8" O.D.	6"
IPH40034	IPH40034WO	4" IPS	6"
IPH50034	IPH50034WO	5" IPS	8"
IPH60034	IPH60034WO	6" IPS	10"
IPH80034	IPH80034WO	8" IPS	12"

* Recommended pipe hanger size for insulation thickness shown. (Order hanger separately)

IPH18230 ARMAFLEX®† INSULATION TAPE

- 30 ft. (9.14 M) roll



†Armaflex® is a registered trademark of Armacell.

1/2" Wall Insulation Thickness

Assembly Part No.	Insert Only Part No.	Pipe/Copper/OD Size	Hanger Size*
IPH03812	IPH03812WO	3/8" O.D.	1 1/4"
IPH01212	IPH01212WO	1/2" O.D.	1 1/4"
IPH05812	IPH05812WO	5/8" O.D.	1 1/2"
IPH03412	IPH03412WO	3/4" O.D.	1 1/2"
IPH07812	IPH07812WO	7/8" O.D.	2"
IPH11812	IPH11812WO	3/4" IPS & 1 1/8" O.D.	2"
IPH13812	IPH13812WO	1 3/8" O.D.	2 1/2"
IPH15812	IPH15812WO	1 5/8" O.D.	2 1/2"
IPH11012	IPH11012WO	1 1/2" IPS & 1 7/8" O.D.	3"
IPH21812	IPH21812WO	2 1/8" O.D.	3"
IPH25812	IPH25812WO	2 5/8" O.D.	3 1/2"
IPH31812	IPH31812WO	3 1/8" O.D.	4"
IPH35812	IPH35812WO	3 5/8" O.D.	5"
IPH41812	IPH41812WO	4 1/8" O.D.	6"
IPH40012	IPH40012WO	4" IPS	6"
IPH50012	IPH50012WO	5" IPS	8"
IPH60012	IPH60012WO	6" IPS	8"

* Recommended pipe hanger size for insulation thickness shown. (Order hanger separately)

1" Wall Insulation Thickness

Assembly Part No.	Insert Only Part No.	Pipe/Copper/OD Size	Hanger Size*
IPH05810	IPH05810WO	5/8" O.D.	2 1/2"
IPH03410	IPH03410WO	3/4" O.D.	2 1/2"
IPH07810	IPH07810WO	7/8" O.D.	3"
IPH11810	IPH11810WO	3/4" IPS & 1 1/8" O.D.	3"
IPH13810	IPH13810WO	1 3/8" O.D.	3 1/2"
IPH15810	IPH15810WO	1 5/8" O.D.	3 1/2"
IPH11010	IPH11010WO	1 1/2" IPS & 1 7/8" O.D.	4"
IPH21810	IPH21810WO	2 1/8" O.D.	4"
IPH25810	IPH25810WO	2 5/8" O.D.	5"
IPH31810	IPH31810WO	3 1/8" O.D.	5"
IPH35810	IPH35810WO	3 5/8" O.D.	6"
IPH41810	IPH41810WO	4 1/8" O.D.	6"
IPH40010	IPH40010WO	4" IPS	8"
IPH50010	IPH50010WO	5" IPS	8"
IPH60010	IPH60010WO	6" IPS	10"
IPH80010	IPH80010WO	8" IPS	12"

* Recommended pipe hanger size for insulation thickness shown. (Order hanger separately)

Reference page 126 for general fitting and standard finish specifications.

B1999 VIBRA CUSHION™

- Packaged 20 Ft. (6.09 m) per carton
- Ideal Isolation Material
- Inhibits Galvanic Corrosion
- Dampens Sound and Vibrations
- Service Temperature Range
-75°F (-60°C) to +375°F (+199°C)
- Wt./Carton 3.8 Lbs. (1.7 kg)

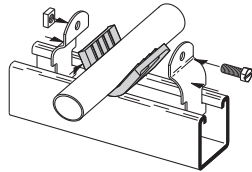

FEATURES

Virba Cushion™ is designed for use with refrigeration lines, HVAC, copper tubing, glass pipe and hydraulic lines. It provides an energy-absorption barrier between the lines and the mounting material and remains flexible thru its entire service range of -75°F (-60°C) to +375°F (+199°C).

This elastomer allows for expansion and contraction within the mounting system and prevents galvanic reaction between dissimilar metals.

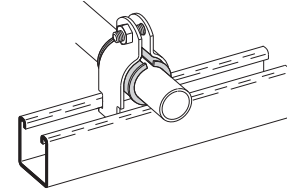

FOR RIGID CONDUIT OR IRON PIPE

Nominal Size	Length of Vibra-Cushion	Use Clamp No.
3/8"	(10) 21/8" (54.0)	B2002
1/2"	(15) 25/8" (66.7)	B2009
3/4"	(20) 31/4" (82.5)	B2031
1"	(25) 41/8" (104.8)	B2004
1 1/4"	(32) 53/16" (131.8)	B2012
1 1/2"	(40) 515/16" (150.8)	B2038
2"	(50) 71/2" (190.5)	B2042
2 1/2"	(65) 9" (228.6)	B2046
3"	(80) 11" (279.4)	B2051
3 1/2"	(90) 12 1/2" (317.5)	B2055
4"	(100) 14 1/2" (368.3)	B2059
5"	(125) 17 7/16" (442.9)	B2067
6"	(150) 20 3/4" (527.0)	B2116

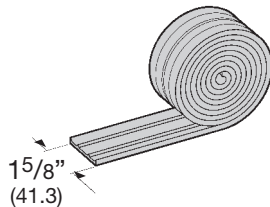

FOR THINWALL (EMT) CONDUIT

Nominal Size	Length of Vibra-Cushion	Use Clamp No.
3/8"	(10) 1 13/16" (46.0)	B2027
1/2"	(15) 2 13/16" (58.7)	B2002
3/4"	(20) 2 7/8" (73.0)	B2003
1"	(25) 3 5/8" (92.1)	B2032
1 1/4"	(32) 4 3/8" (120.6)	B2036
1 1/2"	(40) 5 7/16" (138.1)	B2012
2"	(50) 6 7/8" (174.6)	B2013

FOR COPPER TUBING TYPE L & K

Nominal Size	Length of Vibra-Cushion	Use Clamp No.
1/4"	(6) 1 3/16" (30.2)	B2026
3/8"	(10) 1 9/16" (39.7)	B2027
1/2"	(15) 1 7/8" (47.6)	B2008
5/8"	(17) 2 5/16" (58.7)	B2029
3/4"	(20) 2 3/4" (69.8)	B2030
1"	(25) 3 1/2" (88.9)	B2032
1 1/4"	(32) 4 5/16" (109.5)	B2011
1 1/2"	(40) 5 1/8" (130.2)	B2036
2"	(50) 6 1 1/16" (169.9)	B2013
2 1/2"	(65) 8 1/4" (209.5)	B2014
3"	(80) 9 13/16" (249.2)	B2048
3 1/2"	(90) 11 3/8" (288.9)	B2052
4"	(100) 12 15/16" (328.6)	B2056
5"	(125) 16 1/8" (409.6)	B2064
6"	(150) 19 1/4" (488.9)	B2112
8"	(200) 25 1/2" (647.7)	B2128

ISO PIPE

- Non-adhesive rubber tape
- Fuses to itself
- Water resistant
- Ideal Isolation Material
- Prevents galvanic reaction caused by dissimilar metal contact
- Temperature Range
-140°F (-60°C) to +395°F (+200°C)

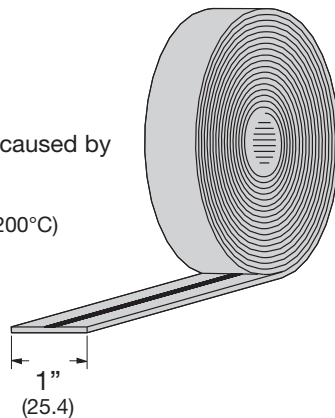

Part No.	Thickness In.	Thickness mm	Ft./Roll Ft.	Ft./Roll m
ISO	.020	(0.5)	36	(11)

BVS Type - Vibra Strip™ for 1 5/8" (41.3) wide B-Line channel

- Fits securely in 1 5/8" wide channel
- Temperature range: -20°F to 212°F
- Ideal Isolation & Vibration Dampening Qualities
- 45 durometer hardness
- Material: Neoprene

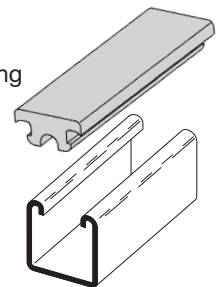

Part No.	Max. Load Lbs. per Lineal In.	Max. Load Lbs. kg/25.4 mm	Length	Std. Pkg.	Wt. Each Lbs. kg
BVS-12	40	(18.1)	12" (304.8)	25	.46 (.21)
BVS-120	40	(18.1)	120" (3048.0)	25	4.60 (2.08)

Reference page 126 for general fitting and standard finish specifications.

Pipe Clamps

B2400 SERIES STANDARD PIPE STRAP

- Safety Factor of 5
- B2400-3/4 thru B2400-8 are UL listed
- Order hardware separately
- Other sizes available upon request
- Material: Sizes - 1/2" - 1 1/2", ASTM A1011 33,000 PSI min. yield;
2" - 12", ASTM A1018 33,000 PSI min. yield;
14"-Larger, ASTM A36
- Standard finish: ZN
- Ductile Iron Sizes Available
- Meets requirements of MSS SP-58 & SP-69 Type 26

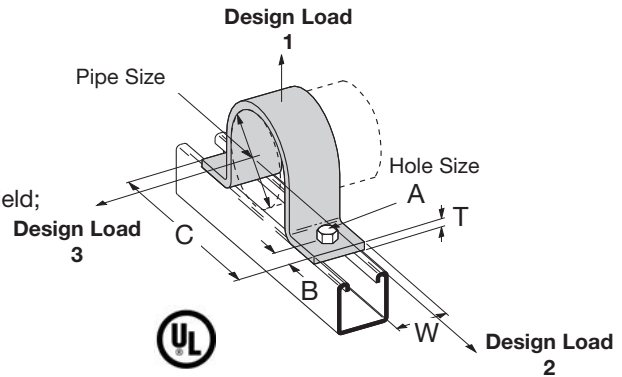

Part No.	Pipe Size		A		B		C		T		W	
B2400-1/2	1/2"	(15)	5/16"	(7.9)	7/16"	(11.1)	2 13/16"	(71.4)	10 Ga.	(3.4)	1 5/8"	(41.3)
B2400-3/4	3/4"	(20)	5/16"	(7.9)	7/16"	(11.1)	3"	(76.2)	10 Ga.	(3.4)	1 5/8"	(41.3)
B2400-1	1"	(25)	5/16"	(7.9)	7/16"	(11.1)	3 17/32"	(89.7)	10 Ga.	(3.4)	1 5/8"	(41.3)
B2400-1 1/4	1 1/4"	(32)	5/16"	(7.9)	7/16"	(11.1)	3 3/4"	(95.2)	10 Ga.	(3.4)	1 5/8"	(41.3)
B2400-1 1/2	1 1/2"	(40)	5/16"	(7.9)	7/16"	(11.1)	4 1/16"	(103.2)	10 Ga.	(3.4)	1 5/8"	(41.3)
B2400-2	2"	(50)	7/16"	(11.1)	1 1/16"	(17.4)	5 21/32"	(143.6)	1/4"	(6.3)	1 5/8"	(41.3)
B2400-2 1/2	2 1/2"	(65)	7/16"	(11.1)	1 1/16"	(17.4)	6 5/32"	(156.3)	1/4"	(6.3)	1 5/8"	(41.3)
B2400-3	3"	(80)	7/16"	(11.1)	1 1/16"	(17.4)	6 25/32"	(172.2)	1/4"	(6.3)	1 5/8"	(41.3)
B2400-3 1/2	3 1/2"	(90)	7/16"	(11.1)	1 1/16"	(17.4)	7 9/32"	(184.9)	1/4"	(6.3)	1 5/8"	(41.3)
B2400-4	4"	(100)	9/16"	(14.3)	1 1/16"	(17.4)	7 25/32"	(197.6)	1/4"	(6.3)	1 5/8"	(41.3)
B2400-5	5"	(125)	9/16"	(14.3)	1 1/16"	(17.4)	8 7/8"	(225.4)	1/4"	(6.3)	1 5/8"	(41.3)
B2400-6	6"	(150)	9/16"	(14.3)	1 1/16"	(17.4)	9 15/16"	(252.4)	1/4"	(6.3)	1 5/8"	(41.3)
B2400-8	8"	(200)	9/16"	(14.3)	1 1/16"	(17.4)	11 13/32"	(304.0)	1/4"	(6.3)	1 5/8"	(41.3)
B2400-10	10"	(250)	9/16"	(14.3)	1 1/16"	(17.4)	14"	(355.6)	1/4"	(6.3)	1 5/8"	(41.3)
B2400-12	12"	(300)	9/16"	(14.3)	1 1/16"	(17.4)	16"	(406.4)	1/4"	(6.3)	1 5/8"	(41.3)
B2400-14	14"	(350)	1 5/16"	(23.8)	1 1/2"	(38.1)	20 3/4"	(527.0)	3/8"	(9.5)	1 3/4"	(44.4)
B2400-16	16"	(400)	1 5/16"	(23.8)	1 1/2"	(38.1)	22 3/4"	(577.8)	3/8"	(9.5)	1 3/4"	(44.4)
B2400-18	18"	(460)	1 5/16"	(23.8)	1 3/4"	(44.4)	27"	(685.8)	1/2"	(12.7)	1 3/4"	(44.4)
B2400-20	20"	(510)	1 5/16"	(23.8)	1 3/4"	(44.4)	29"	(736.6)	1/2"	(12.7)	1 3/4"	(44.4)
B2400-24	24"	(610)	1 5/16"	(23.8)	1 3/4"	(44.4)	33"	(838.2)	1/2"	(12.7)	1 3/4"	(44.4)

Part No.	Design Load 1		Design Load 2		Design Load 3		Wt./C	
	Lbs.	kN	Lbs.	kN	Lbs.	kN	Lbs.	kg
B2400-1/2	600	(2.67)	150	(.67)	105	(.47)	23	(10.4)
B2400-3/4	600	(2.67)	150	(.67)	105	(.47)	26	(11.8)
B2400-1	600	(2.67)	150	(.67)	120	(.53)	31	(14.0)
B2400-1 1/4	600	(2.67)	150	(.67)	120	(.53)	36	(16.3)
B2400-1 1/2	600	(2.67)	150	(.67)	120	(.53)	39	(17.7)
B2400-2	1200	(5.34)	480	(2.14)	180	(.80)	93	(42.2)
B2400-2 1/2	1200	(5.34)	480	(2.14)	180	(.80)	106	(48.1)
B2400-3	1200	(5.34)	480	(2.14)	300	(1.33)	132	(59.9)
B2400-3 1/2	1200	(5.34)	480	(2.14)	300	(1.33)	151	(68.5)
B2400-4	1500	(6.67)	600	(2.67)	450	(2.00)	160	(72.6)
B2400-5	1500	(6.67)	600	(2.67)	450	(2.00)	192	(87.1)
B2400-6	1500	(6.67)	600	(2.67)	450	(2.00)	219	(99.3)
B2400-8	2000	(8.90)	800	(3.56)	600	(2.67)	297	(134.7)
B2400-10	2000	(8.90)	800	(3.56)	600	(2.67)	465	(210.9)
B2400-12	2000	(8.90)	800	(3.56)	600	(2.67)	560	(254.0)
B2400-14	2000	(8.90)	800	(3.56)	600	(2.67)	761	(345.2)
B2400-16	2000	(8.90)	800	(3.56)	600	(2.67)	861	(390.5)
B2400-18	2000	(8.90)	800	(3.56)	600	(2.67)	1297	(588.3)
B2400-20	2000	(8.90)	800	(3.56)	600	(2.67)	1426	(646.8)
B2400-24	2000	(8.90)	800	(3.56)	600	(2.67)	1682	(762.9)

Reference page 126 for general fitting and standard finish specifications.

B437 SERIES TWO PIECE PIPE STRAP

- Clamp halves can turn allowing pipe to be fastened to channel at any direction
- Order hardware separately
- Standard finish: ZN

Part No.	Pipe Size		A		T		Wt./C	
	in	(mm)	in	(mm)	Ga.	(mm)	Lbs.	kg
B437-1/2	1/2"	(15)	5/16"	(7.9)	10 Ga.	(3.4)	22	(10.0)
B437-3/4	3/4"	(20)	5/16"	(7.9)	10 Ga.	(3.4)	26	(11.8)
B437-1	1"	(25)	5/16"	(7.9)	10 Ga.	(3.4)	30	(13.6)
B437-1 1/4	1 1/4"	(32)	5/16"	(7.9)	10 Ga.	(3.4)	35	(15.9)
B437-1 1/2	1 1/2"	(40)	5/16"	(7.9)	10 Ga.	(3.4)	38	(17.2)
B437-2	2"	(50)	7/16"	(11.1)	1/4"	(6.3)	91	(41.3)
B437-2 1/2	2 1/2"	(65)	7/16"	(11.1)	1/4"	(6.3)	104	(47.2)
B437-3	3"	(80)	7/16"	(11.1)	1/4"	(6.3)	130	(58.9)
B437-3 1/2	3 1/2"	(90)	7/16"	(11.1)	1/4"	(6.3)	149	(67.6)
B437-4	4"	(100)	9/16"	(11.1)	1/4"	(6.3)	158	(71.6)
B437-5	5"	(125)	9/16"	(11.1)	1/4"	(6.3)	190	(86.2)
B437-6	6"	(150)	9/16"	(11.1)	1/4"	(6.3)	217	(98.4)
B437-8	8"	(200)	9/16"	(11.1)	1/4"	(6.3)	295	(133.8)

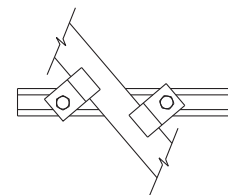
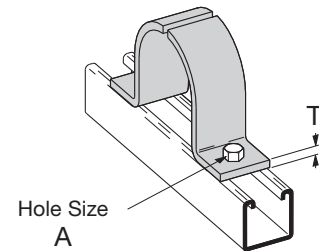

B2417 STRUT MOUNTED PIPE GUIDE

- Copper tubing sizes available - B2417CT Series
- Standard finish: ZN

Part No.	Pipe Size		Minimum Radial Clearance		Includes Clamp No.	Wt./C	
	in	(mm)	in	(mm)		Lbs.	kg
B2417-1/2	1/2"	(15)	1/16"	(1.6)	B2009	22	(10.0)
B2417-3/4	3/4"	(20)	1/16"	(1.6)	B2010	25	(11.3)
B2417-1	1"	(25)	3/32"	(2.3)	B2034	30	(13.6)
B2417-1 1/4	1 1/4"	(32)	3/32"	(2.3)	B2037	47	(21.8)
B2417-1 1/2	1 1/2"	(40)	3/32"	(2.3)	B2039	51	(23.1)
B2417-2	2"	(50)	1/8"	(3.2)	B2043	62	(28.1)
B2417-2 1/2	2 1/2"	(65)	1/8"	(3.2)	B2047	69	(31.3)
B2417-3	3"	(80)	5/32"	(3.9)	B2016	108	(49.0)
B2417-3 1/2	3 1/2"	(90)	5/32"	(3.9)	B2017	118	(53.5)

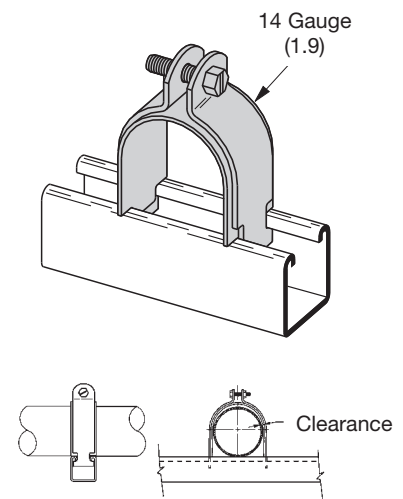

B2070 THRU B2080 PARALLEL PIPE CLAMP

- Safety Factor of 2
- Designed to support pipe or rigid conduit
- Includes:
 - 1 pr. Pipe Clamps
 - 1 pc. Stand Off Plate
 - 1 pc. Slotted Hex Head Machine Screws
 - 1 pc. Square Nut
- Standard finish: ZN

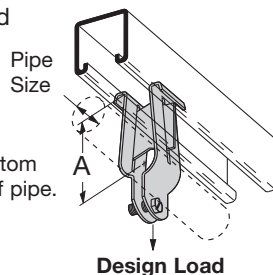

A dimension, from bottom of channel to center of pipe.

Part No.	Pipe Size		A		Material Thickness	Design Load		Wt./C	
	in	(mm)	in	(mm)		Lbs.	kN	Lbs.	kg
B2070	3/8"	(10)	1 11/16"	(42.9)	16 Ga. (1.5)	300	(1.33)	24	(10.9)
B2071	1/2"	(15)	1 3/4"	(44.4)	16 Ga. (1.5)	300	(1.33)	26	(11.8)
B2072	3/4"	(20)	1 7/8"	(47.6)	14 Ga. (1.9)	300	(1.33)	30	(13.6)
B2073	1"	(25)	2"	(50.8)	14 Ga. (1.9)	400	(1.78)	33	(14.9)
B2074	1 1/4"	(32)	2 3/16"	(55.6)	14 Ga. (1.9)	400	(1.78)	36	(16.3)
B2075	1 1/2"	(40)	2 5/16"	(58.7)	12 Ga. (2.6)	500	(2.22)	50	(22.7)
B2076	2"	(50)	2 9/16"	(65.1)	12 Ga. (2.6)	500	(2.22)	55	(24.9)
B2077	2 1/2"	(65)	2 7/8"	(73.0)	12 Ga. (2.6)	500	(2.22)	60	(27.2)
B2078	3"	(80)	3 3/16"	(80.9)	12 Ga. (2.6)	500	(2.22)	66	(29.9)
B2079	3 1/2"	(90)	3 7/16"	(87.3)	11 Ga. (3.0)	500	(2.22)	85	(38.5)
B2080	4"	(100)	3 5/8"	(92.1)	11 Ga. (3.0)	500	(2.22)	95	(43.1)

Reference page 126 for general fitting and standard finish specifications.

Pipe Clamps

B670 SERIES PARALLEL PIPE CLAMP

- Designed to support pipe or rigid conduit parallel to the edge of a beam or angle iron
- Hardware included
- Material: Malleable Iron
- Standard finish: HDG



Part Number	Pipe or Conduit Size		Wt./C	
			Lbs.	kg
B670-3/8	3/8"	(10)	32	(14.5)
B670-1/2	1/2"	(15)	58	(26.3)
B670-3/4	3/4"	(20)	64	(29.0)
B670-1	1"	(25)	70	(31.7)
B670-1 1/4	1 1/4"	(32)	77	(34.9)
B670-1 1/2	1 1/2"	(40)	93	(42.2)
B670-2	2"	(50)	105	(47.6)
B670-2 1/2	2 1/2"	(65)	143	(64.8)
B670-3	3"	(80)	164	(74.4)
B670-3 1/2	3 1/2"	(90)	190	(86.2)
B670-4	4"	(100)	205	(93.0)

B671 SERIES EDGE PIPE CLAMP

- Designed to support pipe or rigid conduit perpendicular to the edge of a beam or angle iron
- Hardware included
- Material: Malleable Iron
- Standard finish: HDG

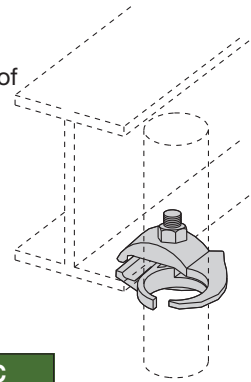

Part Number	Pipe or Conduit Size		Wt./C	
			Lbs.	kg
B671-1/2	1/2"	(15)	67	(30.4)
B671-3/4	3/4"	(20)	71	(32.2)
B671-1	1"	(25)	85	(38.5)
B671-1 1/4	1 1/4"	(32)	91	(41.3)
B671-1 1/2	1 1/2"	(40)	115	(52.1)
B671-2	2"	(50)	135	(61.2)
B671-2 1/2	2 1/2"	(65)	183	(83.0)
B671-3	3"	(80)	230	(104.3)

B422 SERIES RIGHT ANGLE CLAMP

- Safety Factor of 5
- Material: 7 Gauge (4.5)
- Standard finishes: ZN, SS4

Part No.	Conduit Size		A	Design Load Vertical Pull		Wt./C		
				Lbs.	kg	Lbs.	kg	
B422-1/2	1/2"	(15)	2 3/8"	(60.3)	250	(1.11)	38	(17.2)
B422-3/4	3/4"	(20)	2 3/8"	(60.3)	300	(1.33)	39	(17.7)
B422-1	1"	(25)	2 7/8"	(73.0)	400	(1.78)	48	(21.8)
B422-1 1/4	1 1/4"	(32)	2 7/8"	(73.0)	400	(1.78)	50	(22.7)
B422-1 1/2	1 1/2"	(40)	3 1/4"	(82.5)	500	(2.22)	59	(26.7)
B422-2	2"	(50)	3 11/16"	(93.7)	600	(2.67)	75	(34.0)
B422-2 1/2	2 1/2"	(65)	4 1/4"	(107.9)	700	(3.11)	98	(44.4)
B422-3	3"	(80)	4 7/8"	(123.8)	800	(3.56)	111	(50.3)
B422-3 1/2	3 1/2"	(90)	5 7/16"	(138.1)	900	(4.00)	123	(55.8)
B422-4	4"	(100)	6"	(152.4)	1000	(4.45)	135	(61.2)

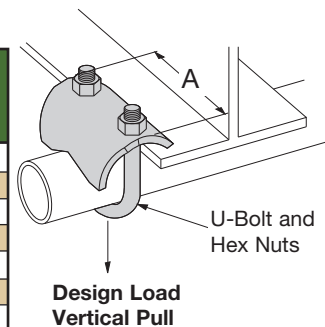

B3367S RETAINING STRAP

- Available in 'L' lengths of 6" (152.4), 8" (203.2), 9" (228.6), 10" (254.0), 12" (304.8), 14" (355.6), 16" (406.4), 18" (457.2)
- Material: Steel
- Standard finishes: ZN, PLN

Part No.	Hole Dia. D	For Use With	Wt./C**	
			Lbs.	kg
B3367S-1-L	7/16"	B422-1/2 & 3/4	33.4	(5.8)
B3367S-2-L	9/16"	B422-1, 1 1/4 & 1 1/2	12.8	(15.1)

** Wt./C based on 6" (152.4) length. For each additional inch in strap length add the following to the Wt./C.
 For B3367S-1 add 5.7 Lbs (2.6 kg)
 For B3367S-2 add 2.2 Lbs (1.0 kg)

Note: Use Fig. 69 (Old B3367-3/8 retaining strap, page 115) for B422-2 thru 4

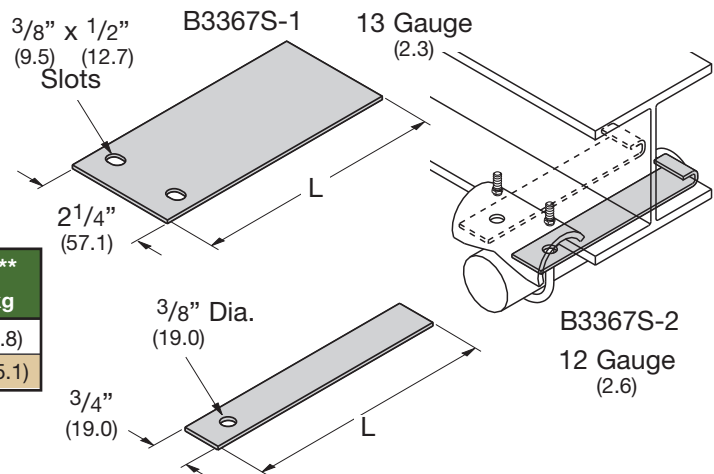

B2301 SERIES ONE HOLE EMT STRAP

- Standard finish: ZN

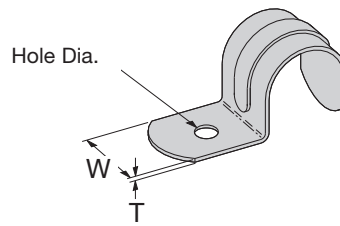

Part No.	Conduit Size		T		W		Hole Dia.		Wt./C	
									Lbs.	kg
B2301-1/2	1/2"	(15)	.050	(1.3)	3/4"	(19.0)	9/32"	(7.1)	2.4	(1.1)
B2301-3/4	3/4"	(20)	.050	(1.3)	7/8"	(22.2)	9/32"	(7.1)	4.2	(1.9)
B2301-1	1"	(25)	.050	(1.3)	1"	(25.4)	9/32"	(7.1)	8.3	(3.7)
B2301-1 1/4	1 1/4"	(32)	.065	(1.6)	1 1/4"	(31.7)	9/32"	(7.1)	11.0	(5.0)
B2301-1 1/2	1 1/2"	(40)	.090	(2.3)	1"	(25.4)	11/32"	(8.7)	14.8	(6.7)
B2301-2	2"	(50)	.090	(2.3)	1 1/4"	(31.7)	13/32"	(10.3)	21.6	(9.8)

B2302 SERIES ONE HOLE RIGID CONDUIT/PIPE STRAP

- Standard finish: ZN

Part No.	Conduit/Pipe Size		T		W		Hole Dia.		Wt./C	
									Lbs.	kg
B2302-1/4	1/4"	(6)	.045	(1.1)	5/8"	(15.9)	13/64"	(5.1)	1.4	(.6)
B2302-3/8	3/8"	(10)	.050	(1.3)	3/4"	(19.0)	9/32"	(7.1)	2.4	(1.1)
B2302-1/2	1/2"	(15)	.050	(1.3)	7/8"	(22.2)	9/32"	(7.1)	3.3	(1.5)
B2302-3/4	3/4"	(20)	.050	(1.3)	7/8"	(22.2)	9/32"	(7.1)	3.8	(1.7)
B2302-1	1"	(25)	.065	(1.6)	1"	(25.4)	9/32"	(7.1)	7.2	(3.2)
B2302-1 1/4	1 1/4"	(32)	.065	(1.6)	1 1/4"	(31.7)	21/64"	(8.3)	11.0	(5.0)
B2302-1 1/2	1 1/2"	(40)	11 Ga.	(3.0)	1"	(25.4)	.380	(9.6)	19.2	(8.7)
B2302-2	2"	(50)	11 Ga.	(3.0)	1 1/4"	(31.7)	.389	(9.9)	28.8	(13.0)
B2302-2 1/2	2 1/2"	(65)	7 Ga.	(4.5)	1 1/4"	(31.7)	.665	(16.9)	55.2	(25.0)
B2302-3	3"	(80)	7 Ga.	(4.5)	1 1/4"	(31.7)	.650	(16.5)	68.0	(30.8)
B2302-3 1/2	3 1/2"	(90)	1/4"	(6.3)	1 1/4"	(31.7)	.622	(15.8)	96.0	(43.5)
B2302-4	4"	(100)	1/4"	(6.3)	1 1/4"	(31.7)	.630	(16.0)	108.0	(49.0)

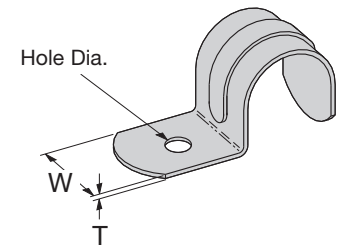

B2084 THRU B2091 ONE HOLE O.D. TUBING CLAMP

- Material: 14 Gauge (1.9) ASTM A1011 33,000 PSI min. yield
- Standard finish: ZN

Part No.	O.D. Size		A		Wt./C	
					Lbs.	kg
B2084	1/4"	(6.3)	7/8"	(22.2)	4.0	(1.8)
B2085	5/16"	(7.9)	29/32"	(23.0)	4.2	(1.9)
B2086	3/8"	(9.5)	31/32"	(24.6)	5.2	(2.3)
B2087	1/2"	(12.7)	1 1/16"	(25.9)	5.8	(2.6)
B2088	5/8"	(15.9)	1 3/32"	(27.8)	7.1	(3.2)
B2089	3/4"	(19.0)	1 5/32"	(29.1)	7.7	(3.5)
B2090	7/8"	(22.2)	1 7/32"	(30.7)	8.7	(3.9)
B2091	1"	(25.4)	1 9/32"	(32.2)	10.0	(4.5)

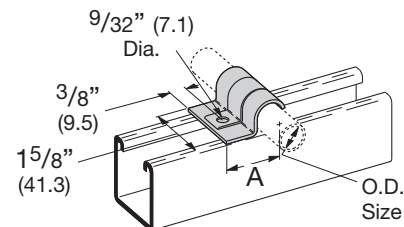

Reference page 126 for general fitting and standard finish specifications.

Pipe Clamps

BL1400 SERIES CONDUIT HANGER

- Safety Factor of 3
- Unless noted all sizes fit both rigid (R) and thinwall (EMT) conduit
- Hardware included
- Standard finishes: ZN, SS4

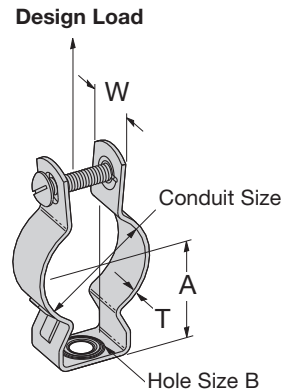

Part No	Conduit Size		A		B		T		W		Design Load		Wt./C	
											Lbs.	kN	Lbs.	kg
BL1400	1/2"	(15)	29/32"	(23.0)	9/32"	(7.1)	16 Ga.	(1.5)	3/4"	(19.0)	590	(2.62)	6	(2.7)
BL1410	3/4"	(20)	31/32"	(24.6)	9/32"	(7.1)	16 Ga.	(1.5)	3/4"	(19.0)	590	(2.62)	7	(3.2)
BL1420	1"	(25)	1 1/4"	(31.7)	9/32"	(7.1)	16 Ga.	(1.5)	3/4"	(19.0)	590	(2.62)	8	(3.6)
BL1425	1 1/4" EMT	(32)	1 1/4"	(31.7)	9/32"	(7.1)	18 Ga.	(1.2)	7/8"	(22.2)	590	(2.62)	10	(4.5)
BL1430	1 1/4" R, 1 1/2" EMT	(32)	1 13/32"	(35.7)	9/32"	(8.7)	18 Ga.	(1.2)	7/8"	(22.2)	590	(2.62)	10	(4.5)
BL1440	1 1/2" R	(40)	1 5/8"	(41.3)	11/32"	(8.7)	16 Ga.	(1.5)	1"	(25.4)	755	(3.36)	17	(7.7)
BL1450	2"	(50)	2 1/16"	(47.6)	11/32"	(8.7)	16 Ga.	(1.5)	1 1/4"	(31.7)	755	(3.36)	25	(11.3)
BL1460	2 1/2"	(65)	2 1/16"	(52.4)	11/32"	(8.7)	16 Ga.	(1.5)	1 1/4"	(31.7)	755	(3.36)	26	(11.8)
BL1470	3"	(80)	2 1/2"	(63.5)	11/32"	(8.7)	16 Ga.	(1.5)	1 1/4"	(31.7)	820	(3.65)	33	(14.9)
BL1480	3 1/2"	(90)	2 3/4"	(69.8)	11/32"	(8.7)	16 Ga.	(1.5)	1 1/4"	(31.7)	850	(3.78)	36	(16.3)
BL1490	4"	(100)	3 1/2"	(88.9)	11/32"	(8.7)	16 Ga.	(1.5)	1 1/4"	(31.7)	1410	(6.27)	40	(18.1)

B3373 SERIES RISER CLAMP

- Safety Factor of 3.5
- B3373-3/4 thru B3373-8 are UL listed
- Includes Hex Head Cap Screws and Hex Nuts
- Standard finishes: ZN, PLN

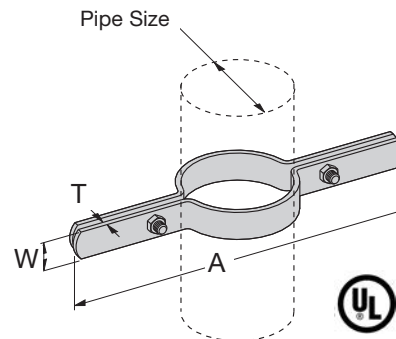

Part No.	Pipe Size		A		Design Load		Wt./C	
					Lbs.	kN	Lbs.	kg
B3373-1/2	1/2"	(15)	9"	(228.6)	255	(1.13)	101	(45.9)
B3373-3/4	3/4"	(20)	9 1/4"	(234.9)	255	(1.13)	105	(47.7)
B3373-1	1"	(25)	9 9/16"	(242.9)	255	(1.13)	109	(49.4)
B3373-1 1/4	1 1/4"	(32)	10"	(254.0)	255	(1.13)	112	(50.9)
B3373-1 1/2	1 1/2"	(32)	10 1/4"	(260.3)	255	(1.13)	113	(51.1)
B3373-2	2"	(40)	10 3/4"	(273.0)	255	(1.13)	165	(75.0)
B3373-2 1/2	2 1/2"	(50)	11 1/4"	(285.7)	390	(1.73)	180	(81.6)
B3373-3	3"	(65)	11 15/16"	(303.2)	530	(2.36)	195	(88.4)
B3373-3 1/2	3 1/2"	(80)	12 3/8"	(314.3)	670	(2.98)	217	(98.5)
B3373-4	4"	(90)	12 7/8"	(327.0)	810	(3.60)	228	(103.5)
B3373-5	5"	(100)	14"	(355.6)	1160	(5.16)	480	(217.7)
B3373-6	6"	(100)	15 3/16"	(385.8)	1570	(6.98)	526	(238.6)
B3373-8	8"	(100)	17 3/4"	(450.8)	2500	(11.12)	957	(434.1)

Reference page 126 for general fitting and standard finish specifications.

B3690 SERIES ADJUSTABLE J HANGER

- Safety Factor of 5
- Material:
 - 12 Ga. (2.6) ASTM A1011 33,000 PSI min. yield
 - 11 Ga. (3.0) ASTM A1011 HSLA Gr. 50 Class 1
 - 7 Ga. (4.5) ASTM A1011 33,000 PSI min. yield and
 - 1/4" (6.3) ASTM A1018 33,000 PSI min. yield
- Standard finish: ZN

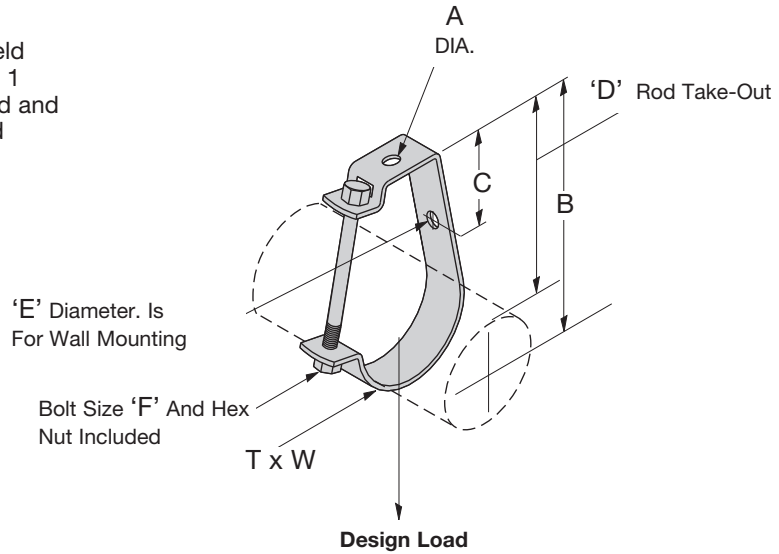
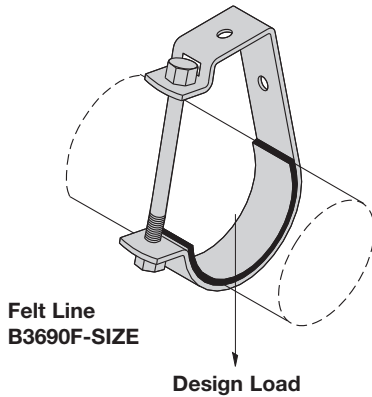

Part No.	Pipe or Conduit Size		A		B		C		D		E		F
B3690-1/2	1/2"	(15)	13/32"	(10.3)	2 ³ /32"	(53.2)	1"	(25.4)	1 ¹¹ /16"	(42.5)	13/32"	(10.3)	1/4"-20 x 2 ¹ /4"
B3690-3/4	3/4"	(20)	13/32"	(10.3)	2 ¹¹ /32"	(59.5)	1"	(25.4)	1 ¹³ /16"	(46.2)	13/32"	(10.3)	1/4"-20 x 2 ¹ /2"
B3690-1	1"	(25)	13/32"	(10.3)	2 ¹⁹ /32"	(65.9)	1"	(25.4)	1 ¹⁵ /16"	(49.2)	13/32"	(10.3)	1/4"-20 x 2 ³ /4"
B3690-1 ¹ / ₄	1 ¹ / ₄ "	(32)	13/32"	(10.3)	2 ¹³ /16"	(71.4)	1"	(25.4)	2"	(50.4)	13/32"	(10.3)	1/4"-20 x 3"
B3690-1 ¹ / ₂	1 ¹ / ₂ "	(40)	13/32"	(10.3)	3 ¹ /16"	(77.8)	1"	(25.4)	2 ¹ / ₈ "	(53.7)	13/32"	(10.3)	1/4"-20 x 3 ¹ / ₄ "
B3690-2	2"	(50)	13/32"	(10.3)	3 ¹ / ₂ "	(88.9)	1"	(25.4)	2 ⁵ /16"	(58.7)	13/32"	(10.3)	1/4"-20 x 3 ¹ / ₂ "
B3690-2 ¹ / ₂	2 ¹ / ₂ "	(65)	9/16"	(14.3)	4 ⁷ /16"	(112.7)	1"	(25.4)	3"	(76.2)	9/16"	(14.3)	3/8"-16 x 4 ¹ / ₂ "
B3690-3	3"	(80)	9/16"	(14.3)	4 ⁷ / ₈ "	(123.8)	1"	(25.4)	3 ¹ / ₈ "	(79.4)	9/16"	(14.3)	3/8"-16 x 5"
B3690-3 ¹ / ₂	3 ¹ / ₂ "	(90)	9/16"	(14.3)	5 ³ /16"	(131.8)	1"	(25.4)	3 ³ /16"	(81.0)	9/16"	(14.3)	3/8"-16 x 5 ¹ / ₂ "
B3690-4	4"	(100)	1 ¹ / ₁₆ "	(17.5)	6 ¹ / ₈ "	(155.6)	1 ¹ / ₄ "	(31.8)	3 ⁷ / ₈ "	(98.4)	9/16"	(14.3)	3/8"-16 x 6 ¹ / ₂ "
B3690-5	5"	(125)	1 ¹ / ₁₆ "	(17.5)	6 ³ / ₄ "	(171.4)	1 ¹ / ₂ "	(38.1)	4"	(100.8)	9/16"	(14.3)	3/8"-16 x 7 ¹ / ₂ "
B3690-6	6"	(150)	1 ³ / ₁₆ "	(20.6)	7 ³ / ₄ "	(196.8)	1 ³ / ₁₆ "	(30.2)	4 ⁷ / ₁₆ "	(112.7)	9/16"	(14.3)	3/8"-16 x 8 ¹ / ₂ "
B3690-8	8"	(200)	1 ³ / ₁₆ "	(20.6)	9 ¹ / ₄ "	(235.0)	1"	(25.4)	4 ¹⁵ / ₁₆ "	(125.4)	9/16"	(14.3)	3/8"-16 x 10 ¹ / ₂ "

Part No.	T	W	Design Load		Wt./C	
			Lbs.	kN	Lbs.	kg
B3690-1/2	12 Ga. (2.6)	3/4" (19.0)	400	(1.78)	20	(9.1)
B3690-3/4	12 Ga. (2.6)	3/4" (19.0)	400	(1.78)	23	(10.4)
B3690-1	12 Ga. (2.6)	3/4" (19.0)	400	(1.78)	24	(10.9)
B3690-1 ¹ / ₄	12 Ga. (2.6)	3/4" (19.0)	400	(1.78)	27	(12.2)
B3690-1 ¹ / ₂	12 Ga. (2.6)	3/4" (19.0)	400	(1.78)	29	(13.1)
B3690-2	12 Ga. (2.6)	3/4" (19.0)	400	(1.78)	32	(14.5)
B3690-2 ¹ / ₂	11 Ga. (3.0)	1 ¹ / ₄ " (31.7)	800	(3.56)	71	(32.2)
B3690-3	11 Ga. (3.0)	1 ¹ / ₄ " (31.7)	800	(3.56)	77	(34.9)
B3690-3 ¹ / ₂	11 Ga. (3.0)	1 ¹ / ₄ " (31.7)	800	(3.56)	84	(38.1)
B3690-4	7 Ga. (4.5)	1 ¹ / ₄ " (31.7)	800	(3.56)	139	(63.0)
B3690-5	7 Ga. (4.5)	1 ¹ / ₄ " (31.7)	800	(3.56)	166	(75.3)
B3690-6	1/4" (6.3)	1 ¹ / ₄ " (31.7)	1000	(4.45)	226	(102.5)
B3690-8	1/4" (6.3)	1 ¹ / ₂ " (38.1)	1200	(5.34)	332	(150.6)

Reference page 126 for general fitting and standard finish specifications.

Pipe Hangers

Fig. 4B SERIES (Formerly B386 Series)
SUSPENSION ROD PIPE STRAP

- Safety Factor of 3
- Includes Hex Head Cap Screws and Hex Nuts
- Standard finishes: ZN, GRN

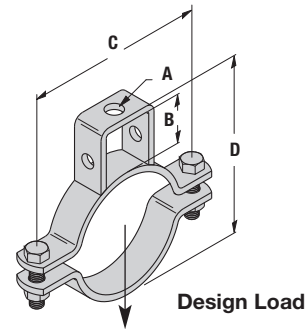

Part No.	Pipe Size		Rod Size		B		C		D		Bolt Size	Design Load		Wt./C	
	in.	(mm)	A	in. (mm)	in. (mm)	in. (mm)	in. (mm)	in. (mm)	Lbs.	(kN)		Lbs.	(kg)		
4B-3/4	3/4"	(20)	3/8"-16	1" (25.4)	27/8" (73.0)	25/8" (66.7)	5/16"-18	330	(1.47)	56	(3.6)				
4B-1	1"	(25)	3/8"-16	1" (25.4)	31/4" (82.5)	215/16" (74.6)	5/16"-18	330	(1.47)	60	(3.6)				
4B-11/4	11/4"	(32)	3/8"-16	1" (25.4)	39/16" (90.6)	31/4" (82.5)	5/16"-18	330	(1.47)	74	(4.5)				
4B-11/2	11/2"	(40)	3/8"-16	1" (25.4)	313/16" (96.8)	37/16" (87.3)	5/16"-18	330	(1.47)	79	(5.0)				
4B-2	2"	(50)	3/8"-16	1 1/2" (38.1)	51/8" (130.2)	45/8" (117.5)	5/16"-18	440	(1.78)	156	(5.0)				
4B-21/2	21/2"	(65)	1/2"-13	1 3/4" (44.4)	55/8" (142.9)	53/8" (136.5)	3/8"-16	440	(1.78)	176	(5.4)				
4B-3	3"	(80)	1/2"-13	1 7/8" (47.6)	63/4" (171.4)	61/8" (155.5)	3/8"-16	660	(2.93)	198	(6.3)				
4B-31/2	31/2"	(90)	1/2"-13	2" (50.8)	71/4" (184.1)	63/4" (171.4)	3/8"-16	660	(2.93)	219	(7.2)				
4B-4	4"	(100)	5/8"-11	2" (50.8)	85/8" (219.1)	71/4" (184.1)	2/2"-13	800	(3.56)	288	(8.1)				
4B-5	5"	(125)	5/8"-11	2" (50.8)	97/8" (250.8)	85/16" (211.1)	5/8"-11	980	(4.36)	390	(8.1)				
4B-6	6"	(150)	3/4"-10	2 1/8" (54.0)	1015/16" (277.8)	91/2" (241.3)	5/8"-11	980	(4.36)	448	(8.1)				
4B-8	8"	(200)	7/8"-9	2 1/8" (54.0)	137/16" (341.2)	111/2" (292.1)	3/4"-10	1200	(5.34)	691	(8.1)				

B394 SERIES
PIPE STRAP

- Safety Factor of 3
- Includes:
 - 1 Pair Pipe Clamps with Hex Head Cap Screws and Hex Nuts
 - 1 Hanger Strap
- Standard finishes: ZN

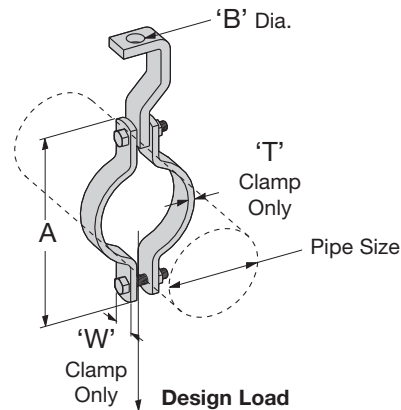

Part No.	Pipe Size		A		B		T		W		Design Load		Wt./C	
	in.	(mm)	in. (mm)	in. (mm)	in. (mm)	in. (mm)	in. (mm)	in. (mm)	Lbs.	(kN)	Lbs.	(kg)		
B394-3/4	3/4"	(20)	35/16" (84.1)	7/16" (11.1)	1/8" (3.2)	1" (25.4)	500	(2.22)	71	(32.2)				
B394-1	1"	(25)	33/4" (95.2)	7/16" (11.1)	1/8" (3.2)	1" (25.4)	500	(2.22)	76	(34.5)				
B394-11/4	11/4"	(32)	4" (101.6)	7/16" (11.1)	1/8" (3.2)	1" (25.4)	500	(2.22)	77	(34.9)				
B394-11/2	11/2"	(40)	45/16" (109.5)	7/16" (11.1)	1/8" (3.2)	1" (25.4)	800	(3.56)	79	(35.8)				
B394-2	2"	(50)	51/2" (139.7)	7/16" (11.1)	1/4" (6.3)	1" (25.4)	1040	(4.62)	166	(75.3)				
B394-21/2	21/2"	(65)	63/8" (161.9)	9/16" (14.3)	1/4" (6.3)	1" (25.4)	1040	(4.62)	179	(81.2)				
B394-3	3"	(80)	7" (177.8)	9/16" (14.3)	1/4" (6.3)	1" (25.4)	1040	(4.62)	190	(86.2)				
B394-31/2	31/2"	(90)	79/16" (192.1)	9/16" (14.3)	1/4" (6.3)	1" (25.4)	1040	(4.62)	203	(92.1)				
B394-4	4"	(100)	85/8" (219.1)	11/16" (17.4)	1/4" (6.3)	1 1/4" (31.7)	1040	(4.62)	320	(145.1)				
B394-5	5"	(125)	93/4" (247.6)	11/16" (17.4)	1/4" (6.3)	1 1/4" (31.7)	1040	(4.62)	353	(160.1)				
B394-6	6"	(150)	115/8" (295.3)	13/16" (20.6)	3/8" (9.5)	1 1/2" (38.1)	1615	(7.18)	637	(288.9)				
B394-8	8"	(200)	137/8" (352.4)	13/16" (20.6)	3/8" (9.5)	1 1/2" (38.1)	1615	(7.18)	837	(379.6)				

Reference page 126 for general fitting and standard finish specifications.

B591 SERIES PIPE BRACKET SADDLE AND CLAMP

- Safety Factor of 3
- Inside brace not required on B591-2 and B591-2¹/₂
- Includes:
 - 1 pc. Saddle bottom
 - 1 pc. Saddle top (clamp)
 - 2 pcs. Hex Head Cap Screws
 - 2 pcs. Hex Nuts
- Standard finish: ZN

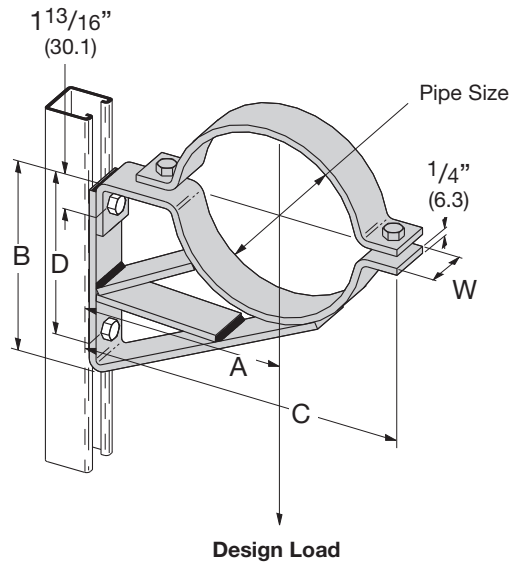

Part No.	Pipe Size		A		B		C		D		W		Design Load		Wt./C	
	in	mm	in	mm	in	mm	in	mm	in	mm	in	mm	Lbs.	kN	Lbs.	kg
B591-2	2"	(50)	4 ¹ / ₂ "	(114.3)	4 ¹ / ₂ "	(114.3)	7 ³ / ₁₆ "	(182.6)	3 ¹ / ₁₆ "	(77.8)	1 ⁵ / ₈ "	(41.3)	1235	(5.53)	290	(131.5)
B591-2¹/₂	2 ¹ / ₂ "	(65)	5"	(127.0)	5"	(127.0)	7 ¹⁵ / ₁₆ "	(201.6)	3 ⁹ / ₁₆ "	(90.5)	1 ⁵ / ₈ "	(41.3)	1180	(5.29)	330	(149.7)
B591-3	3"	(80)	5 ¹ / ₂ "	(139.7)	5 ³ / ₄ "	(146.0)	8 ³ / ₄ "	(222.2)	3 ¹³ / ₁₆ "	(96.8)	1 ⁵ / ₈ "	(41.3)	1125	(5.04)	439	(199.1)
B591-3¹/₂	3 ¹ / ₂ "	(90)	6"	(152.4)	6 ³ / ₄ "	(171.4)	9 ¹ / ₂ "	(241.3)	4 ⁹ / ₁₆ "	(115.9)	1 ⁵ / ₈ "	(41.3)	1070	(4.79)	490	(222.2)
B591-4	4"	(100)	6 ¹ / ₂ "	(165.1)	6 ³ / ₄ "	(171.4)	10 ¹ / ₄ "	(260.3)	6 ¹ / ₁₆ "	(128.6)	1 ⁵ / ₈ "	(41.3)	1015	(4.55)	545	(247.2)
B591-5	5"	(125)	7 ¹ / ₂ "	(190.5)	8"	(203.2)	12 ¹ / ₈ "	(308.0)	6 ¹ / ₁₆ "	(154.0)	1 ⁵ / ₈ "	(41.3)	960	(4.30)	666	(302.1)
B591-6	6"	(150)	8"	(203.2)	8 ³ / ₄ "	(222.2)	13 ³ / ₁₆ "	(335.0)	6 ¹³ / ₁₆ "	(173.0)	1 ⁵ / ₈ "	(41.3)	905	(4.05)	724	(328.4)
B591-8	8"	(200)	9"	(228.6)	10 ¹ / ₂ "	(266.7)	15 ⁹ / ₁₆ "	(395.3)	8 ⁹ / ₁₆ "	(217.5)	2"	(50.8)	850	(3.81)	1087	(493.0)

Reference page 126 for general fitting and standard finish specifications.

Pipe Block

B356

PIPE BLOCK-2" (50) TO 8" (200) PIPE

- Required hardware not included:
 - 1 pc. $\frac{3}{8}$ "-16 x 1" Hex Head Cap Screw
 - 1 pc. $\frac{3}{8}$ "-16 Channel Nut
- Material: $\frac{1}{4}$ " (6.3) thick $1\frac{5}{8}$ " (41.3) wide
ASTM A1018 33,000 PSI min. yield
- Standard finish: ZN
- Wt./C 42 Lbs. (19.0 kg) Per Pair

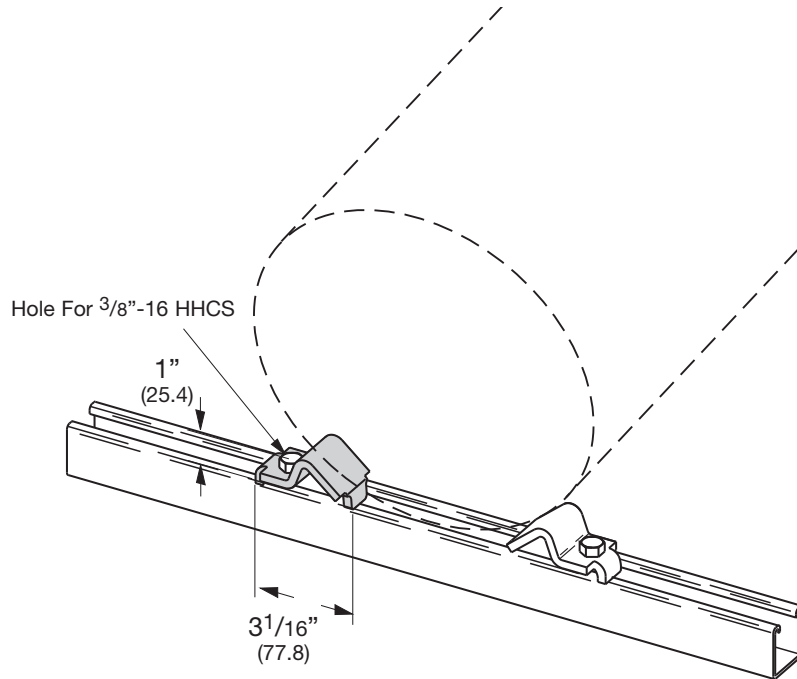

B218

PIPE ROLLERS-1/2" (15) TO 8" (200) PIPE

- Design Load 500 Lbs. (2.22 kN)
- Safety Factor of 5
- When used with B3160 thru B3165 Saddles
(See Pipe Hanger Catalog)
- Malleable Iron Rollers
- Sold in pairs
- Required hardware not included:
2 pcs. 1/2"-13 x 1 1/4" Hex Head Cap Screws
2 pcs. 1/2"-13 Channel Nuts
- Standard finish: ZN
- Wt./C 256 Lbs. (116.1 kg) Per Pair

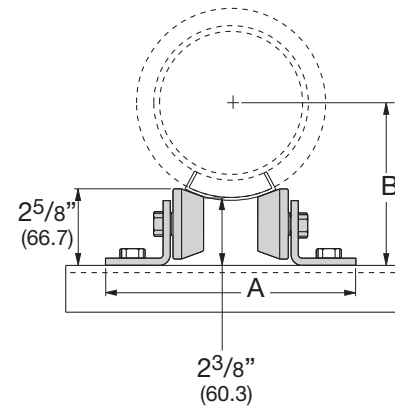
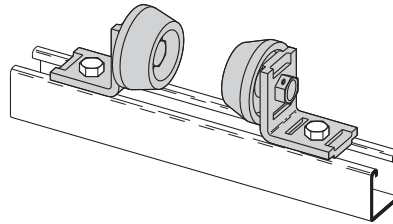

REFERENCE CHART - A DIMENSION

Pipe Size	Insulation Thickness in. (mm)													
	0" (0.0)		1" (25.4)		1 1/2" (38.1)		2" (50.8)		2 1/2" (63.5)		3" (76.2)		4" (101.6)	
1/2" (15)	7 1/4"	(184.1)	-	-	-	-	-	-	-	-	-	-	-	-
3/4" (20)	7 1/4"	(184.1)	7 1/4"	(184.1)	7 5/8"	(193.7)	8"	(203.2)	-	-	-	-	-	-
1" (25)	7 1/4"	(184.1)	7 1/4"	(184.1)	7 5/8"	(193.7)	8 1/4"	(209.5)	-	-	-	-	-	-
1 1/4" (32)	7 1/4"	(184.1)	7 1/4"	(184.1)	8"	(203.2)	8 1/4"	(209.5)	-	-	-	-	-	-
1 1/2" (40)	7 1/4"	(184.1)	7 5/8"	(193.7)	8"	(203.2)	8 1/2"	(215.9)	9"	(228.6)	-	-	-	-
2" (50)	7 1/4"	(184.1)	7 5/8"	(193.7)	8 1/2"	(215.9)	8 1/2"	(215.9)	9"	(228.6)	-	-	-	-
2 1/2" (65)	7 1/4"	(184.1)	8"	(203.2)	8 1/2"	(215.9)	9"	(228.6)	10"	(254.0)	-	-	-	-
3" (80)	7 1/4"	(184.1)	8 1/2"	(215.9)	9"	(228.6)	9"	(228.6)	10"	(254.0)	10"	(254.0)	-	-
3 1/2" (90)	7 1/4"	(184.1)	8 1/2"	(215.9)	9"	(228.6)	10"	(254.0)	10"	(254.0)	10"	(254.0)	-	-
4" (100)	7 5/8"	(193.7)	9"	(228.6)	9"	(228.6)	10"	(254.0)	10"	(254.0)	11"	(279.4)	-	-
5" (125)	8 1/2"	(215.9)	9"	(228.6)	10"	(254.0)	10"	(254.0)	11"	(279.4)	11"	(279.4)	12"	(304.8)
6" (150)	9"	(228.6)	10"	(254.0)	10"	(254.0)	11"	(279.4)	11"	(279.4)	11"	(279.4)	12"	(304.8)
8" (200)	10"	(254.0)	11"	(279.4)	11"	(279.4)	11"	(279.4)	12"	(304.8)	-	-	-	-

REFERENCE CHART - B DIMENSION

Pipe Size	Insulation Thickness in. (mm)													
	0" (0.0)		1" (25.4)		1 1/2" (38.1)		2" (50.8)		2 1/2" (63.5)		3" (76.2)		4" (101.6)	
1/2" (15)	2 11/16"	(68.3)	-	-	-	-	-	-	-	-	-	-	-	-
3/4" (20)	2 13/16"	(71.4)	3 7/8"	(98.4)	4 3/8"	(111.1)	4 7/8"	(123.8)	-	-	-	-	-	-
1" (25)	2 15/16"	(74.6)	4 3/16"	(106.4)	4 11/16"	(119.1)	5 1/16"	(128.6)	-	-	-	-	-	-
1 1/4" (32)	3 1/8"	(79.4)	4 3/16"	(106.4)	4 5/8"	(117.5)	5 1/8"	(130.2)	-	-	-	-	-	-
1 1/2" (40)	3 1/4"	(82.5)	4 3/8"	(111.1)	4 7/8"	(123.8)	5 5/16"	(134.9)	5 3/4"	(146.0)	-	-	-	-
2" (50)	3 9/16"	(90.5)	4 11/16"	(119.1)	5 1/16"	(128.6)	5 5/8"	(142.9)	6 1/16"	(154.0)	-	-	-	-
2 1/2" (65)	3 13/16"	(96.8)	4 7/8"	(123.8)	5 5/16"	(134.9)	6"	(152.4)	6 3/8"	(161.9)	-	-	-	-
3" (80)	4 1/8"	(104.8)	5 1/16"	(128.6)	5 9/16"	(141.3)	6 1/8"	(155.6)	6 7/16"	(163.5)	7"	(177.8)	-	-
3 1/2" (90)	4 3/8"	(111.1)	5 5/16"	(134.9)	5 13/16"	(147.6)	6 1/4"	(158.7)	6 11/16"	(169.9)	7 1/4"	(184.1)	-	-
4" (100)	4 5/8"	(117.5)	5 9/16"	(141.3)	6 1/16"	(154.0)	6 7/16"	(163.5)	6 15/16"	(176.2)	7 3/8"	(187.3)	-	-
5" (125)	5"	(127.0)	6 1/16"	(154.0)	6 7/16"	(163.5)	7"	(177.8)	7 3/8"	(187.3)	7 7/8"	(200.0)	8 13/16"	(223.8)
6" (150)	5 1/2"	(139.7)	6 7/16"	(163.5)	6 15/16"	(176.2)	7 3/8"	(187.3)	7 15/16"	(201.6)	8 1/2"	(215.9)	9 1/2"	(241.3)
8" (200)	6 15/16"	(160.3)	7 3/8"	(187.3)	7 15/16"	(201.6)	8 7/16"	(214.3)	8 15/16"	(227.0)	-	-	-	-

Reference page 126 for general fitting and standard finish specifications.

Pipe Rollers

B219

PIPE ROLLER SERIES - 3/4" (20) TO 12" (300) PIPE

- Design Load 750 Lbs. (3.33 kN)
- Safety Factor of 5
- Requires field assembly
- When used with B3160 thru B3165 Saddles
(See Pipe Hanger Catalog)
- Malleable Iron Rollers
- Sold in pairs
- Required hardware not included:
2 pcs. 1/2"-13 x 1 1/4" Hex Head Cap Screws
2 pcs. 1/2"-13 Channel Nuts
- Reference sizing chart on page 135
- Standard finish: ZN

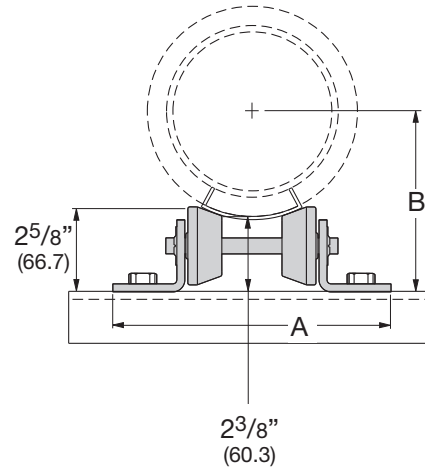
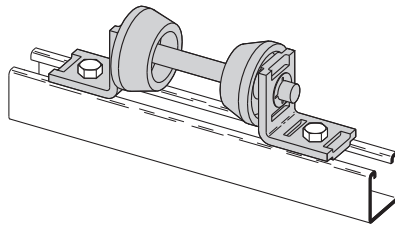

REFERENCE CHART - A DIMENSION

Part No.	A		Wt./C PR	
	in.	(mm)	Lbs.	kg
B219	7 1/4"	(184.1)	253	(114.7)
B219-1	8"	(203.2)	258	(117.0)
B219-2	9"	(228.6)	263	(119.3)
B219-3	10"	(254.0)	269	(122.0)
B219-4	10 7/8"	(276.2)	274	(124.8)
B219-5	11 5/8"	(295.3)	279	(126.5)

REFERENCE CHART - B DIMENSION

Pipe Size	Insulation Thickness in. (mm)													
	0" (0.0)		1" (25.4)		1 1/2" (38.1)		2" (50.8)		2 1/2" (63.5)		3" (76.2)		4" (101.6)	
1/2" (15)	2 11/16"	(68.3)	-	-	-	-	-	-	-	-	-	-	-	-
3/4" (20)	2 13/16"	(71.4)	3 7/8"	(98.4)	4 1/2"	(114.3)	4 7/8"	(123.8)	-	-	-	-	-	-
1" (25)	2 15/16"	(74.6)	4 3/16"	(106.4)	4 5/8"	(117.5)	5 1/16"	(128.6)	-	-	-	-	-	-
1 1/4" (32)	3 1/8"	(79.4)	4 3/16"	(106.4)	4 5/8"	(117.5)	5 1/8"	(130.2)	-	-	-	-	-	-
1 1/2" (40)	3 1/4"	(82.5)	4 7/16"	(112.7)	4 7/8"	(123.8)	5 1/4"	(133.3)	5 3/4"	(146.0)	-	-	-	-
2" (50)	3 9/16"	(90.5)	4 5/8"	(117.5)	5 3/16"	(131.8)	5 1/2"	(139.7)	6 1/16"	(154.0)	-	-	-	-
2 1/2" (65)	3 3/4"	(95.2)	4 7/8"	(123.8)	5 1/4"	(133.3)	6"	(152.4)	6 3/8"	(161.9)	-	-	-	-
3" (80)	4 1/8"	(104.8)	5 1/8"	(130.2)	5 9/16"	(141.3)	6 1/16"	(154.0)	6 7/16"	(163.5)	6 15/16"	(176.2)	-	-
3 1/2" (90)	4 1/4"	(107.9)	5 1/4"	(133.3)	5 13/16"	(147.6)	6 1/4"	(158.7)	6 11/16"	(169.9)	7 1/16"	(179.4)	-	-
4" (100)	4 9/16"	(115.9)	5 1/2"	(139.7)	6 1/16"	(154.0)	6 7/16"	(163.5)	6 15/16"	(176.2)	7 3/8"	(187.3)	-	-
5" (125)	5 1/16"	(128.6)	6 1/16"	(154.0)	6 7/16"	(163.5)	7"	(177.8)	7 3/8"	(187.3)	7 7/8"	(200.0)	8 15/16"	(227.0)
6" (150)	5 7/16"	(138.1)	6 7/16"	(163.5)	6 15/16"	(176.2)	7 3/8"	(187.3)	7 7/8"	(200.0)	8 15/16"	(211.1)	9 9/16"	(242.9)
8" (200)	6 3/8"	(161.9)	7 7/16"	(188.9)	7 15/16"	(201.6)	8 3/8"	(212.7)	9"	(228.6)	-	-	-	-
10" (250)	7 5/16"	(185.7)	8 3/16"	(208.0)	-	-	-	-	-	-	-	-	-	-
12" (300)	8 1/4"	(209.5)	-	-	-	-	-	-	-	-	-	-	-	-

Reference B219 sizing chart on page 149

Reference page 126 for general fitting and standard finish specifications.

B219 SIZING CHART

Pipe Size		Insulation Thickness in. (mm)						
		0" (0.0)	1" (25.4)	1 1/2" (38.1)	2" (50.8)	2 1/2" (63.5)	3" (76.2)	4" (101.6)
1/2"	(15)	B219	-	-	-	-	-	-
3/4"	(20)	B219	B219	B219	B219-1	-	-	-
1"	(25)	B219	B219	B219-1	B219-1	-	-	-
1 1/4"	(32)	B219	B219	B219-1	B219-1	-	-	-
1 1/2"	(40)	B219	B219	B219-1	B219-2	B219-2	-	-
2"	(50)	B219	B219-1	B219-1	B219-2	B219-2	-	-
2 1/2"	(65)	B219	B219-1	B219-2	B219-2	B219-3	-	-
3"	(80)	B219	B219-1	B219-2	B219-2	B219-3	B219-3	-
3 1/2"	(90)	B219-1	B219-2	B219-2	B219-3	B219-3	B219-4	-
4"	(100)	B219-1	B219-2	B219-2	B219-3	B219-3	B219-4	-
5"	(125)	B219-1	B219-2	B219-3	B219-3	B219-4	B219-4	B219-5
6"	(150)	B219-2	B219-3	B219-3	B219-4	B219-4	B219-5	B219-5
8"	(200)	B219-3	B219-4	B219-4	B219-5	B219-5	-	-
10"	(250)	B219-4	B219-5	-	-	-	-	-
12"	(300)	B219-5	-	-	-	-	-	-

Reference page 126 for general fitting and standard finish specifications.

Pipe Rollers

B379

PIPE ROLLERS-6" (150) TO 18" (450) PIPE

- Design Load 1500 Lbs. (6.67 kN)
- Safety Factor of 5
- Requires field assembly
- When used with B3160 thru B3165 Saddles
(See Pipe Hanger Catalog)
- Malleable Iron Rollers
- Sold in pairs
- Required hardware not included:
2 pcs. 1/2"-13 x 1 1/4" Hex Head Cap Screws
2 pcs. 1/2"-13 Channel Nuts
- Standard finish: ZN
- Wt./C 889 Lbs. (403.2 kg)

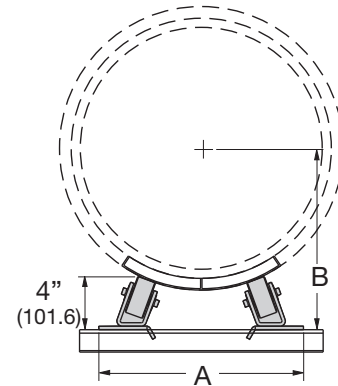
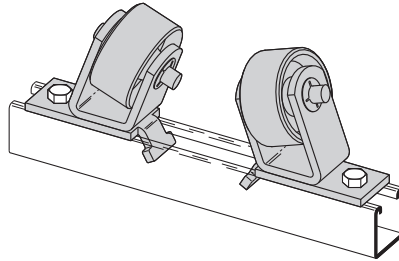

REFERENCE CHART - A DIMENSION

Pipe Size	Insulation Thickness in. (mm)													
	0" (0.0)		1" (25.4)		1 1/2" (38.1)		2" (50.8)		2 1/2" (63.5)		3" (76.2)		4" (101.6)	
6" (150)	9 9/16"	(242.9)	10 3/16"	(258.8)	10 5/8"	(269.9)	11"	(279.4)	11 3/8"	(288.9)	11 3/4"	(298.4)	12 1/2"	(317.5)
8" (200)	10 1/4"	(260.3)	11 1/16"	(281.0)	11 3/8"	(288.9)	11 3/4"	(298.4)	12 3/16"	(309.6)	12 1/2"	(317.5)	13 1/4"	(336.5)
10" (250)	11"	(279.4)	11 3/4"	(298.4)	12 1/8"	(308.0)	12 1/2"	(317.5)	12 13/16"	(325.4)	13 1/8"	(333.4)	13 7/8"	(352.4)
12" (300)	11 11/16"	(296.9)	12 9/16"	(319.1)	12 7/8"	(327.0)	13 1/4"	(336.5)	13 9/16"	(344.5)	13 7/8"	(352.4)	14 5/8"	(371.5)
14" (350)	12 1/16"	(306.4)	12 7/8"	(327.0)	13 3/16"	(335.0)	13 9/16"	(344.5)	13 7/8"	(352.4)	14 1/4"	(361.9)	14 7/8"	(377.8)
16" (400)	12 3/4"	(323.8)	13 1/2"	(342.9)	13 7/8"	(352.4)	14 13/16"	(360.4)	14 1/2"	(368.3)	14 7/8"	(377.8)	15 1/2"	(393.7)
18" (450)	13 1/2"	(342.9)	14 1/4"	(361.9)	14 5/8"	(371.5)	15"	(381.0)	15 5/16"	(388.9)	15 5/8"	(396.9)	16 5/16"	(414.3)

REFERENCE CHART - B DIMENSION

Pipe Size	Insulation Thickness in. (mm)													
	0" (0.0)		1" (25.4)		1 1/2" (38.1)		2" (50.8)		2 1/2" (63.5)		3" (76.2)		4" (101.6)	
6" (150)	6 7/8"	(174.6)	7 7/8"	(200.0)	8 3/8"	(212.7)	8 7/8"	(225.4)	9 3/8"	(238.1)	9 7/8"	(250.8)	10 15/16"	(277.8)
8" (200)	7 13/16"	(198.4)	8 7/8"	(225.4)	9 3/8"	(238.1)	9 7/8"	(250.8)	10 7/16"	(265.1)	10 15/16"	(277.8)	11 7/8"	(301.6)
10" (250)	8 13/16"	(223.8)	9 7/8"	(250.8)	10 7/16"	(265.1)	10 15/16"	(277.8)	11 3/8"	(288.9)	11 7/8"	(301.6)	12 13/16"	(325.4)
12" (300)	9 3/4"	(247.6)	10 15/16"	(277.8)	11 3/8"	(288.9)	11 7/8"	(301.6)	12 5/16"	(312.7)	12 13/16"	(325.4)	13 3/4"	(349.2)
14" (350)	10 5/16"	(261.9)	11 3/8"	(288.9)	11 7/8"	(301.6)	12 5/16"	(312.7)	12 13/16"	(325.4)	13 1/4"	(336.5)	14 1/4"	(361.9)
16" (400)	11 5/16"	(287.3)	12 5/16"	(312.7)	12 13/16"	(325.4)	13 1/4"	(336.5)	13 3/4"	(349.2)	14 1/4"	(361.9)	15 1/8"	(384.2)
18" (450)	12 1/4"	(311.1)	13 1/4"	(336.5)	13 3/4"	(349.2)	14 3/16"	(360.4)	14 11/16"	(373.1)	15 1/8"	(384.2)	16 1/16"	(408.0)

Reference page 126 for general fitting and standard finish specifications.

B479

PIPE ROLLERS-16" (400) TO 30" (750) PIPE

- Design Load 2000 Lbs. (8.89 kN)
- Safety Factor of 5
- Requires field assembly
- When used with B3160 thru B3165 Saddles
(See Pipe Hanger Catalog)
- Malleable Iron Rollers
- Sold in pieces
- Required hardware not included:
4 pcs. 1/2"-13 x 1 1/4" Hex Head Cap Screws
4 pcs. 1/2"-13 Channel Nuts
- Standard finish: ZN
- Wt./C 889 Lbs. (403.2 kg)

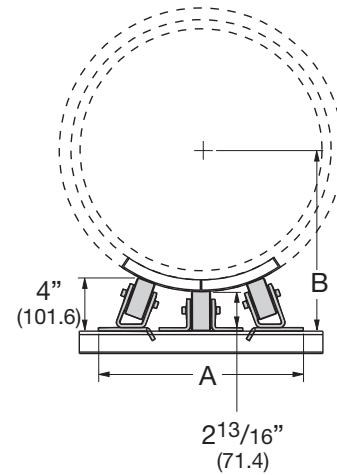
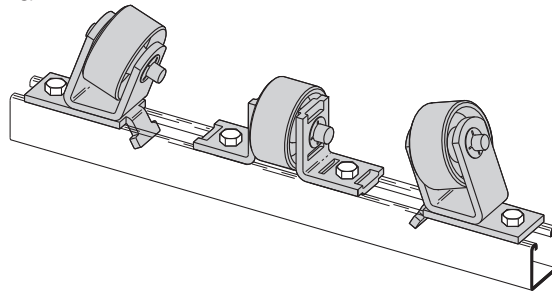

REFERENCE CHART - A DIMENSION

Pipe Size	Insulation Thickness in. (mm)													
	0" (0.0)		1" (25.4)		1 1/2" (38.1)		2" (50.8)		2 1/2" (63.5)		3" (76.2)		4" (101.6)	
16" (400)	15 3/16"	(385.8)	15 5/8"	(396.9)	15 7/8"	(403.2)	16"	(406.4)	16 1/4"	(412.7)	16 1/2"	(419.1)	17"	(431.8)
18" (450)	15 1/2"	(393.7)	16"	(406.4)	16 3/16"	(411.2)	16 3/8"	(415.9)	16 9/16"	(420.7)	16 3/4"	(425.4)	17 3/16"	(436.6)
20" (500)	16"	(406.4)	16 3/8"	(415.9)	16 9/16"	(420.7)	16 7/8"	(428.6)	16 15/16"	(430.2)	17 3/16"	(436.6)	17 1/2"	(444.5)
24" (600)	16 13/16"	(427.0)	17 5/16"	(439.7)	17 1/2"	(444.5)	17 1/2"	(444.5)	17 11/16"	(449.3)	17 7/8"	(454.0)	18 1/8"	(460.4)
30" (750)	17 13/16"	(452.4)	18 1/4"	(463.5)	18 3/8"	(466.7)	18 9/16"	(471.5)	18 7/8"	(476.2)	18 7/8"	(479.4)	19 1/4"	(488.9)

REFERENCE CHART - B DIMENSION

Pipe Size	Insulation Thickness in. (mm)													
	0" (0.0)		1" (25.4)		1 1/2" (38.1)		2" (50.8)		2 1/2" (63.5)		3" (76.2)		4" (101.6)	
16" (400)	10 13/16"	(274.6)	11 15/16"	(303.2)	12 3/8"	(314.3)	12 15/16"	(328.6)	13 3/8"	(339.7)	13 15/16"	(354.0)	14 15/16"	(379.4)
18" (450)	11 7/8"	(301.6)	12 15/16"	(328.6)	13 7/16"	(341.3)	13 15/16"	(354.0)	14 7/16"	(366.7)	14 15/16"	(379.4)	15 15/16"	(404.8)
20" (500)	12 3/16"	(325.4)	13 15/16"	(354.0)	14 7/16"	(366.7)	14 7/8"	(377.8)	15 7/16"	(392.1)	15 7/8"	(403.2)	16 15/16"	(430.2)
24" (600)	14 13/16"	(376.2)	15 7/8"	(403.2)	16 3/8"	(415.9)	16 7/8"	(428.6)	17 3/8"	(441.3)	17 7/8"	(454.0)	18 7/8"	(479.4)
30" (750)	17 13/16"	(452.4)	18 7/8"	(479.4)	19 3/8"	(492.1)	19 7/8"	(504.8)	20 3/8"	(517.5)	20 5/16"	(531.8)	21 15/16"	(557.2)

Reference page 126 for general fitting and standard finish specifications.

DURA-BLOK™ Rooftop Supports

Our DURA-BLOK products gives you a versatile and long-term solution for all your roof top support needs. Designed with flexibility in mind, DURA-BLOK is ideal for roof top support applications such as pipe, HVAC, duct, conduit, cable tray, and roof walkways.

Manufactured to provide years of service in harsh, roof top environments, DURA-BLOK is made from 100% recycled rubber, require no supplemental rubber pads, and will not float or blow away. 1" gaps between blocks allow water to flow freely around longer assemblies. For added strength, the DURA-BLOK support channel is through bolted on all sizes. For added visibility, a reflective strip is incorporated on both sides of each DURA-BLOK.

Beyond product durability, DURA-BLOK helps to dampen vibration, are not sharp or abrasive and require no roof penetration to maximize existing roof life - and roof structural and environmental integrity.

Recommended Torque (In channels)

See page 44 Channel Nuts & Hardware section

Materials & Finishes

See appropriate fitting's pages.
Alternative finishes available upon request.

Metric

Metric dimensions are shown in parentheses.
Unless noted, all metric dimensions are in millimeters.



DURA-BLOK™ Rooftop Supports

SUPPORT BASES ONLY

- Base only - see chart for height, width and length.
- 100% recycled rubber, UV resistant.
- Load Rating - Ultimate Uniform Load (See Chart Below)*
- DURA-BLOK channel support is designed as an economical support for piping systems, cable tray, HVAC equipment and many other applications. The DURA-BLOK is UV resistant and suitable for any type of roofing material or other flat surfaces. Material effectively accepts screw fasteners for securing accessories.



Part No.	Height x Width x Length		Wt./Each		Load Rating	
	In.	(mm)	Lbs.	(kg)	Lbs.	(kN)
DBM	4" x 6" x 4.8"	(101.6 x 152.4 x 121.9)	2.35	(1.07)	200	(0.89)
DBP	4" x 6" x 9.6"	(101.6 x 152.4 x 243.8)	4.48	(2.03)	500	(2.22)

DB SERIES SUPPORT BASE WITH B44 CHANNEL

- Base with 14 ga. (1.9mm) galvanized channel 1" high (25.4mm) - see chart for height, width and length.
- 100% recycled rubber, UV resistant.
- Load Rating - Ultimate Uniform Load (See Chart Below)*
- DURA-BLOK DB-Series channel support is designed for superior support of piping systems, cable tray, HVAC equipment, walkway systems and many other applications. The DURA-BLOK is UV resistant and suitable for installation on any type of roofing material or other flat surfaces. (For pipe straps/clamps, rollers and roller supports that can be used with these DURA-BLOK supports, see page 158)
- For sloped roofs use B634 adjustable hinge fittings (see page 84).



Part No.	Height x Width x Length		Wt./Each		Load Rating	
	In.	(mm)	Lbs.	(kg)	Lbs.	(kN)
DB5	5" x 6" x 4.8"	(127.0 x 152.4 x 121.9)	2.75	(125)	200	(0.89)
DB10	5" x 6" x 9.6"	(127.0 x 152.4 x 243.8)	5.28	(2.39)	500	(2.22)
DB20	5" x 6" x 20.2"	(127.0 x 152.4 x 513.1)	10.63	(4.82)	1000	(4.45)
DB30	5" x 6" x 30.8"	(127.0 x 152.4 x 782.3)	15.99	(7.25)	1500	(6.67)
DB40	5" x 6" x 41.4"	(127.0 x 152.4 x 1051.5)	21.34	(9.68)	2000	(8.89)
DB48	5" x 6" x 52.0"	(127.0 x 152.4 x 1320.8)	26.70	(12.40)	2500	(11.12)

DB6 SERIES SUPPORT BASE WITH B12 CHANNEL

- Base with 12 ga. (2.6mm) galvanized channel 27/16" high (61.9mm) - see chart for height, width and length.
- 100% recycled rubber, UV resistant.
- Load Rating - Ultimate Uniform Load (See Chart Below)*
- DURA-BLOK DB-Series channel support is designed for superior support of piping systems, cable tray, HVAC equipment, walkway systems and many other applications. The DURA-BLOK is UV resistant and suitable for installation on any type of roofing material or other flat surfaces. (For pipe straps/clamps, rollers and roller supports that can be used with these DURA-BLOK supports, see page 158)
- For sloped roofs use B634 adjustable hinge fittings (see page 84).



Part No.	Height x Width x Length		Wt./Each		Load Rating	
	In.	(mm)	Lbs.	(kg)	Lbs.	(kN)
DB610	6 ⁷ / ₁₆ " x 6" x 9.6"	(163.5 x 152.4 x 243.8)	6.36	(2.88)	500	(2.22)
DB620	6 ⁷ / ₁₆ " x 6" x 20.2"	(163.5 x 152.4 x 513.1)	12.90	(5.85)	1000	(4.45)
DB630	6 ⁷ / ₁₆ " x 6" x 30.8"	(163.5 x 152.4 x 782.3)	19.45	(8.82)	1500	(6.67)
DB640	6 ⁷ / ₁₆ " x 6" x 41.4"	(163.5 x 152.4 x 1051.5)	26.00	(11.79)	2000	(8.89)
DB648	6 ⁷ / ₁₆ " x 6" x 52.0"	(163.5 x 152.4 x 1320.8)	32.55	(14.76)	2500	(11.12)

* **General Note:** Consult roofing manufacturer or engineer for roof load capacity. The weakest point may be the insulation board beneath the rubber membrane.

Reference page 152 for general fitting and standard finish specifications.

DURA-BLOK™ Rooftop Supports

DB10 SERIES SUPPORT BASES WITH B22 CHANNEL

- Two (2) bases bridged with 12 ga. (2.6mm) galvanized channel
1⁵/₈" high (41.3mm) - see chart for height, width and length.
- 100% recycled rubber, UV resistant.
- Load Rating: 1000 lbs. (4.45kN) (Uniform Load)*
- DURA-BLOK DB10-Series channel support is designed for superior support of piping systems, cable tray, HVAC equipment, walkway systems and many other applications. The DURA-BLOK is UV resistant and suitable for installation on any type of roofing material or other flat surfaces. (For pipe straps/clamps, rollers and roller supports that can be used with these DURA-BLOK supports, see page 158)



DB10-36

Part No.	Height x Width x Length In. (mm)		Wt./Each Lbs. (kg)	
DB10-28	5 ⁵ / ₈ " x 6" x 28"	(142.9 x 152.4 x 711.2)	13.16	(5.97)
DB10-36	5 ⁵ / ₈ " x 6" x 36"	(142.9 x 152.4 x 914.4)	14.36	(6.51)
DB10-42	5 ⁵ / ₈ " x 6" x 42"	(142.9 x 152.4 x 1066.8)	15.52	(7.04)
DB10-50	5 ⁵ / ₈ " x 6" x 50"	(142.9 x 152.4 x 1270.0)	16.45	(7.46)
DB10-60	5 ⁵ / ₈ " x 6" x 60"	(142.9 x 152.4 x 1524.0)	17.94	(8.14)



DB10-50

DBM SERIES SUPPORT BASE WITH RISER ROD & CLAMP

- Base with 3/8"-16 threaded rod and B3198H clamp - see chart for height, width and length
- 100% recycled rubber, UV resistant.
- Load Rating** 50 lbs. (0.22kN) (Ultimate Load)*
- DURA-BLOK DBM-Series pipe/tubing support is designed for support of single piping systems where elevation adjustment is needed. The DURA-BLOK is UV resistant and suitable for installation on any type of roofing material or other flat surfaces.



DBM-2CT



DBM-1

Part No.	Clamp Part No.†	Block -Height x Width x Length In. (mm)		Height** In.	Min.-Max. (mm)	Wt./Each Lbs. (kg)	
DBM-1/2CT	B3198HCT-1/2	4" x 6" x 4.8"	(101.6 x 152.4 x 121.9)	9.69"-11.19"	(246.1-284.2)	2.75	(1.25)
DBM-3/4CT	B3198HCT-3/4	4" x 6" x 4.8"	(101.6 x 152.4 x 121.9)	9.84"-11.34"	(249.9-2288.0)	2.76	(1.25)
DBM-1CT	B3198HCT-1	4" x 6" x 4.8"	(101.6 x 152.4 x 121.9)	9.95"-11.45"	(252.7-290.8)	2.84	(1.29)
DBM-11/4CT	B3198HCT-11/4	4" x 6" x 4.8"	(101.6 x 152.4 x 121.9)	10.13"-11.63"	(257.3-295.4)	2.95	(1.34)
DBM-11/2CT	B3198HCT-11/2	4" x 6" x 4.8"	(101.6 x 152.4 x 121.9)	10.28"-11.78"	(261.1-299.2)	2.96	(1.34)
DBM-2CT	B3198HCT-2	4" x 6" x 4.8"	(101.6 x 152.4 x 121.9)	10.53"-12.03"	(267.4-305.5)	3.03	(1.37)
DBM-1/2	B3198H-1/2	4" x 6" x 4.8"	(101.6 x 152.4 x 121.9)	9.86"-11.36"	(250.4-288.5)	2.78	(1.26)
DBM-3/4	B3198H-3/4	4" x 6" x 4.8"	(101.6 x 152.4 x 121.9)	10.06"-11.56"	(255.5-293.6)	2.84	(1.29)
DBM-1	B3198H-1	4" x 6" x 4.8"	(101.6 x 152.4 x 121.9)	10.14"-11.64"	(257.5-295.6)	2.86	(1.30)
DBM-11/4	B3198H-11/4	4" x 6" x 4.8"	(101.6 x 152.4 x 121.9)	10.25"-11.75"	(260.3-298.4)	2.93	(1.33)
DBM-11/2	B3198H-11/2	4" x 6" x 4.8"	(101.6 x 152.4 x 121.9)	10.42"-11.92"	(264.6-302.7)	2.99	(1.36)
DBM-2	B3198H-2	4" x 6" x 4.8"	(101.6 x 152.4 x 121.9)	10.66"-12.16"	(270.7-308.8)	3.10	(1.41)

† See Pipe Hanger Catalog for dimensions and specifications. ** From bottom of rubber block to center of pipe/tubing.

* **General Note:** Consult roofing manufacturer or engineer for roof load capacity.
The weakest point may be the insulation board beneath the rubber membrane.

Reference page 152 for general fitting and standard finish specifications.

DURA-BLOK™ Rooftop Supports

DBE SERIES SUPPORT BASE WITH ROD RISERS & CHANNEL



- Base with (2) 1/2" electro zinc all threaded rod risers - Top channel is 1" (25.4mm) tall. See chart for adjustable height x wide x length.
- 100% recycled rubber, UV resistant.
- Load Rating* 200 lbs. (0.89kN) (To increase load capacity use load distribution plate CLDP10)
- DURA-BLOK DBE-Series channel support is designed as a superior support of piping systems, cable tray, HVAC equipment and many other applications where elevation adjustment is critical. The DURA-BLOK is UV resistant and suitable for installation on any type of roofing material or other flat surfaces. (For pipe straps/clamps, rollers and roller supports that can be used with these DURA-BLOK supports, see page 158)



Part No.	Adjustable Height x Width x Length In. (mm)		Wt./Each Lbs. (kg)	
DBE10-8	5 1/2-8" x 6" x 9.6"	(139.7-152.4 x 152.4 x 243.8)	5.68	(2.58)
DBE10-12	5 1/2-12" x 6" x 9.6"	(139.7-304.8 x 152.4 x 243.8)	5.72	(2.59)
DBE10-16	5 1/2-16" x 6" x 9.6"	(139.7-406.4 x 152.4 x 243.8)	5.76	(2.61)

DBR SERIES SUPPORT BASE WITH ROD RISERS & PIPE ROLL



- Base with (2) 1/2" electro zinc all threaded rod risers and a B3114-3 1/2" pipe roll with sockets - base is 4" (101.6mm) high x 6" (152.4mm) wide x 9.6" (243.8mm) long. Overall height is 12" (304.8mm) from bottom of base to contact point on roller.
- Pipe roll & sockets for up to 3 1/2" (90) pipe sizes.
- 100% recycled rubber, UV resistant.
- Load Rating* 200 lbs. (0.89kN) (To increase load capacity use load distribution plate CLDP10)
- DURA-BLOK DBR-Series support is designed to support pipe up to 3 1/2" (90) nominal size where difference in elevation is required and longitudinal movement is expected. The DURA-BLOK is UV resistant and approved for installation on any type of roofing material or other flat surfaces.



Part No.	Adjustable Height x Width x Length In. (mm)		Wt./Each Lbs. (kg)	
DBR10-12	up to 12" x 6" x 9.6"	(up to 304.8 x 152.4 x 243.8)	8.20	(3.72)

CLDP10 LOAD DISTRIBUTION PLATE

- 11 ga. (3.0mm) steel plate with slots.
- Dimensions: 1 5/8" (41.3mm) wide x 9 1/2" (241.3mm) long.
- DURA-BLOK CLDP10 load bearing stabilizer plate increases load ratings for DBE Series and DBR Series by allowing the load from the threaded rods to be distributed over the length of the base instead of the point load where the rods attach to the base.

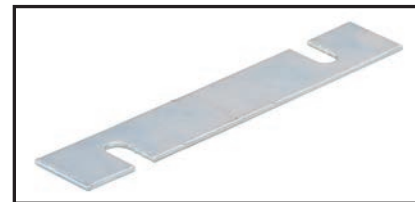

Part No.	Thickness x Width x Length In. (mm)		Wt./Each Lbs. (kg)	
CLDP10	11 Ga. x 1 5/8" x 9 1/2"	(3.0 x 41.3 x 241.3)	0.53	(0.24)



Loosen hex nuts and slide plate under the flat washers

Retighten the hex nuts with plate in place



* **General Note:** Consult roofing manufacturer or engineer for roof load capacity. The weakest point may be the insulation board beneath the rubber membrane.

Reference page 152 for general fitting and standard finish specifications.

DURA-BLOK™ Rooftop Supports

DB_DS SERIES SUPPORT BASES WITH B22SH VERTICAL & HORIZONTAL CHANNEL MEMBERS

- Product is shipped unassembled.
- Two (2) DB20 bases with 14 ga. (1.9mm) galvanized channel 1" high (25.4mm) -
Bases are 5" (127.0mm) high x 6" (152.4mm) wide x 20.2" (513.1mm) long.
Vertical & Horizontal Riser Channels (SH Style) - 1⁵/₈" (41.3mm) x 1⁵/₈" (41.3mm) x 12 ga. (2.6mm)
Fittings & Hardware - Electro-Plated Steel
- 100% recycled rubber, UV resistant.
- Ultimate Load Rating: 1000 lbs. (4.45kN) (Uniform Load)*
- DURA-BLOK DB_DS-Series channel support with risers is designed for superior support of piping systems, cable tray, HVAC equipment, walkway systems and many other applications. The DURA-BLOK is UV resistant and suitable for installation on any type of roofing material or other flat surfaces.
(For pipe straps/clamps, rollers and roller supports that can be used with these DURA-BLOK supports, see page 158)

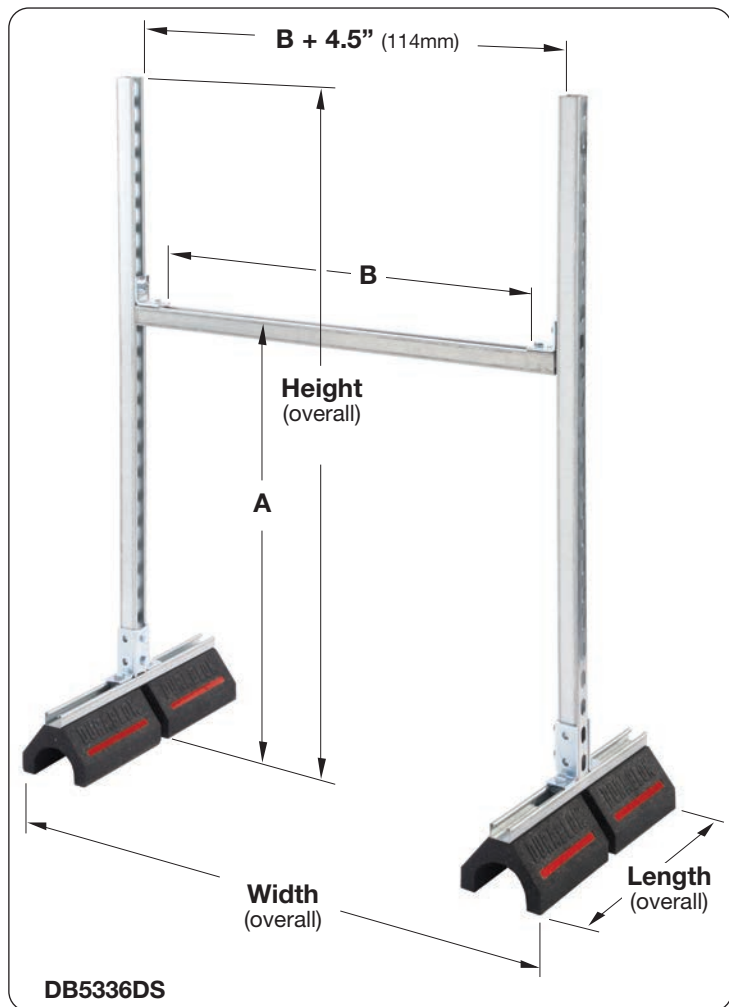

* **General Note:** Consult roofing manufacturer or engineer for roof load capacity.
The weakest point may be the insulation board beneath the rubber membrane.

Reference page 152 for general fitting and standard finish specifications.

DURA-BLOK™ Rooftop Supports

DB_DS SERIES cont.

Part No.	A Min. to Max.		B	
	In.	(mm)	In.	(mm)
DB2318DS	10.56" to 20.75"	(268 to 527)	13 ¹ / ₂ "	(343)
DB2918DS	10.56" to 26.75"	(268 to 679)	13 ¹ / ₂ "	(343)
DB4118DS	10.56" to 38.75"	(268 to 984)	13 ¹ / ₂ "	(343)
DB5318DS	10.56" to 50.75"	(268 to 1289)	13 ¹ / ₂ "	(343)
DB2324DS	10.56" to 20.75"	(268 to 527)	19 ¹ / ₂ "	(495)
DB2924DS	10.56" to 26.75"	(268 to 679)	19 ¹ / ₂ "	(495)
DB4124DS	10.56" to 38.75"	(268 to 984)	19 ¹ / ₂ "	(495)
DB5324DS	10.56" to 50.75"	(268 to 1289)	19 ¹ / ₂ "	(495)
DB2336DS	10.56" to 20.75"	(268 to 527)	31 ¹ / ₂ "	(800)
DB2936DS	10.56" to 26.75"	(268 to 679)	31 ¹ / ₂ "	(800)
DB4136DS	10.56" to 38.75"	(268 to 984)	31 ¹ / ₂ "	(800)
DB5336DS	10.56" to 50.75"	(268 to 1289)	31 ¹ / ₂ "	(800)
DB2348DS	10.56" to 20.75"	(268 to 527)	43 ¹ / ₂ "	(1105)
DB2948DS	10.56" to 26.75"	(268 to 679)	43 ¹ / ₂ "	(1105)
DB4148DS	10.56" to 38.75"	(268 to 984)	43 ¹ / ₂ "	(1105)
DB5348DS	10.56" to 50.75"	(268 to 1289)	43 ¹ / ₂ "	(1105)

Part No.	Height (overall)		Width (overall)		Length (overall)		Wt./Each	
	In.	(mm)	In.	(mm)	In.	(mm)	lbs.	(kg)
DB2318DS	23"	(584)	25 ⁵ / ₈ "	(651)	20.2"	(513)	33.31	(15.11)
DB2918DS	29"	(736)	25 ⁵ / ₈ "	(651)	20.2"	(513)	35.00	(15.88)
DB4118DS	41"	(1041)	25 ⁵ / ₈ "	(651)	20.2"	(513)	38.40	(17.42)
DB5318DS	53"	(1346)	25 ⁵ / ₈ "	(651)	20.2"	(513)	41.80	(18.96)
DB2324DS	23"	(584)	31 ⁵ / ₈ "	(803)	20.2"	(513)	34.15	(15.49)
DB2924DS	29"	(736)	31 ⁵ / ₈ "	(803)	20.2"	(513)	35.84	(16.26)
DB4124DS	41"	(1041)	31 ⁵ / ₈ "	(803)	20.2"	(513)	39.25	(17.80)
DB5324DS	53"	(1346)	31 ⁵ / ₈ "	(803)	20.2"	(513)	42.65	(19.34)
DB2336DS	23"	(584)	43 ⁵ / ₈ "	(1108)	20.2"	(513)	35.84	(16.26)
DB2936DS	29"	(736)	43 ⁵ / ₈ "	(1108)	20.2"	(513)	37.56	(17.03)
DB4136DS	41"	(1041)	43 ⁵ / ₈ "	(1108)	20.2"	(513)	40.95	(18.57)
DB5336DS	53"	(1346)	43 ⁵ / ₈ "	(1108)	20.2"	(513)	44.34	(20.11)
DB2348DS	23"	(584)	55 ⁵ / ₈ "	(1415)	20.2"	(513)	37.55	(17.03)
DB2948DS	29"	(736)	55 ⁵ / ₈ "	(1415)	20.2"	(513)	39.25	(17.80)
DB4148DS	41"	(1041)	55 ⁵ / ₈ "	(1415)	20.2"	(513)	42.65	(19.34)
DB5348DS	53"	(1346)	55 ⁵ / ₈ "	(1415)	20.2"	(513)	46.03	(20.88)

A = Adjustable height from bottom of DURA-BLOK to top of horizontal channel.
 B = Space between fittings that support horizontal channel.
 Height (overall) = Distance from bottom of DURA-BLOK to top of upright channel.
 Width (overall) = Distance from outside-to-outside of DURA-BLOK supports.
 Length (overall) = Distance from end-to-end of DURA-BLOK supports.

Reference page 152 for general fitting and standard finish specifications.

DURA-BLOK™ Rooftop Supports

DBR SERIES SUPPORT BASES WITH B42 CHANNEL & PIPE ROLLER

- Base with 14 ga. (1.9mm) galvanized channel 1" high (25.4mm) tall - see chart for height, width and length.
- 100% recycled rubber, UV resistant.
- Load Rating: (See Chart Below)*
- DURA-BLOK DBR-Series support is designed to support pipe where longitudinal movement is expected. The DURA-BLOK is UV resistant and approved for installation on any type of roofing material or other flat surfaces.



Part No.	Roller Part No.†	Block & Channel -Height x Width x Length In.	Height** In. (mm)	Wt./Each Lbs. (kg)	Load Rating Lbs. (kN)
DBR2-3¹/₂	B3126-2 to 3 ¹ / ₂	5" x 6" x 9.6" (127.0 x 152.4 x 243.8)	7.09" (180)	5.28 (2.39)	500 (2.22)
DBR4-6	B3126-4 to 6	5" x 6" x 9.6" (127.0 x 152.4 x 243.8)	7.09" (180)	10.63 (4.82)	500 (2.22)
DBR8-10	B3126-8-10	5" x 6" x 20.2" (127.0 x 152.4 x 513.1)	8.34" (212)	15.99 (7.25)	1000 (4.45)
DBR12-14	B3126-12-14	5" x 6" x 20.2" (127.0 x 152.4 x 513.1)	9.38" (238)	21.34 (9.68)	1000 (4.45)
DBR16-20	B3126-16-20	5" x 6" x 20.2" (127.0 x 152.4 x 513.1)	9.78" (248)	26.70 (12.11)	1000 (4.45)

† See Pipe Hanger Catalog for dimensions and specifications. ** From bottom of rubber block to bottom of pipe/tubing.

Compatible Components Available to make DURA-BLOK bases more versatile

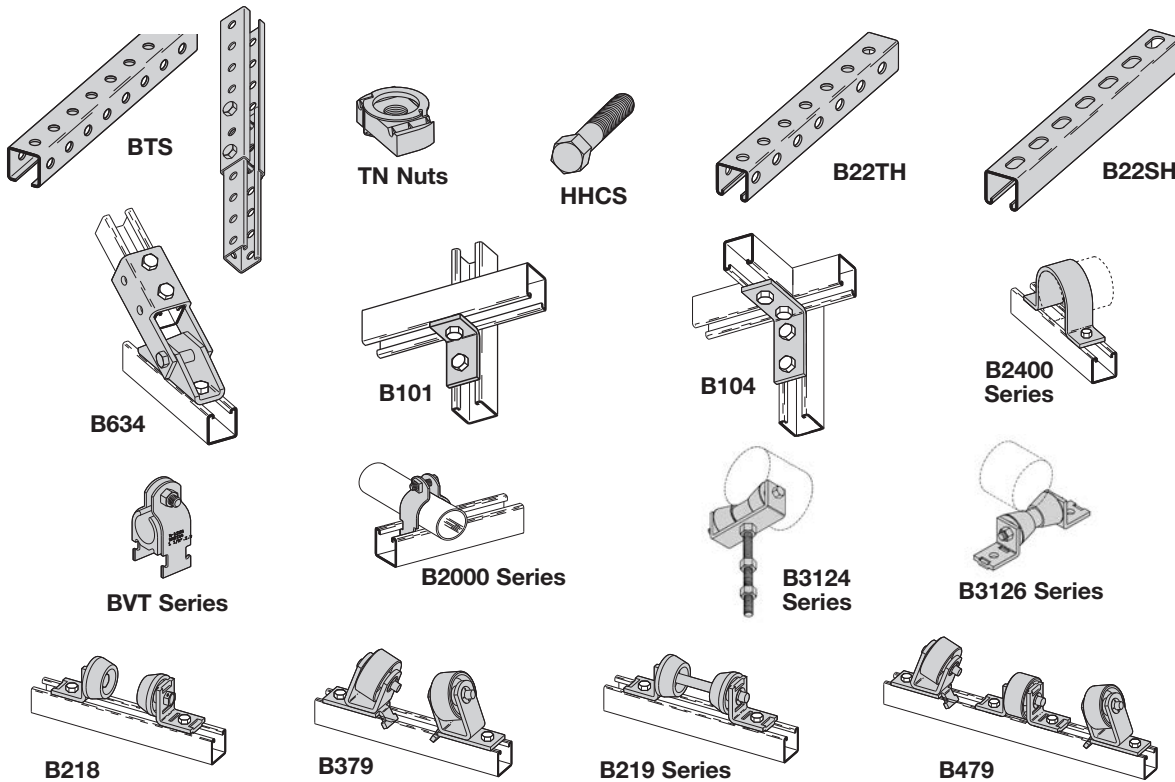

Above rollers can be mounted on DB Series, DB6 Series, and DB10 Series units.

Reference page 152 for general fitting and standard finish specifications.

DURA-BLOK™ Rooftop Supports

ROOFTOP APPLICATIONS



DURA-BLOK Supports

DURA-BLOK™ Rooftop Supports

ROOFTOP SUPPORTS IN WALKWAY APPLICATIONS



- Safety Grating is available with slip resistant GRATE-LOCK™, helping provide a safe walkway for foot traffic on the roof.
- Easy to install, elevated design, creates an identifiable path for foot traffic helping prevent wear and tear to the roof surface.
- The cross-over design offers safe passage over existing cabling, piping, cable tray or any other interference on the rooftop.
- The self cleaning pattern allows water and dirt to easily flow through, helping make the grating an ideal walkway in all weather conditions.
- Handrail options are available

DURA-BLOK Supports



Electrical Accessories

A complete system of top quality, time saving products, designed for surface metal raceways, lighting and cable supports. Innovative designs offer many installation advantages. B-Line's surface raceways are U.L. listed and meet the requirements of the National Electrical Code, Article 384.

Surface Raceways

Our channel provides structural support in addition to a raceway system.

For U.L. wire fill see chart on page 230-231.

Cable Supports

A full range of clamps and saddles are offered in porcelain, thermoplastic elastomer and maple. Our maple clamps, Insulclamp™ cable clamps and porcelain saddles are furnished complete with steel clamps (electro-plated) and Everdur hardware where required.

Materials & Finishes*

Steel products are made from low carbon steel strips or plates. Porcelain saddles and clamps are made by dry process and white glazed (porcelain dielectric strength is 50 volts per mil). Maple clamps are made from kiln-dried maple wood, paraffin impregnated.

Finish Code	Finish	Specification
PLN	Plain	ASTM A1011 33,000 PSI min. yield
ZN	Electro-Plated Zinc	ASTM B633 SC3 Type III
GRN	DURA-GREEN™	
GALV	Pre-Galvanized	ASTM B653
YZN	Yellow Zinc Chromate	ASTM B633 SC3 Type II

*Unless otherwise noted.

Design Load

Design load data published includes a Safety Factor of 3.0 (Safety Factor = Ratio of ultimate load to the design load).

U.L. listed raceway channels:

B11, B11KO6	B32, B32KO6
B12, B12KO6	B42, B42KO6
B22, B22KO6	B52, B52KO6
B24, B24KO6	B54, B54KO6
B26, B26KO6	B56, B56KO6

U.L. File No. E29637

In all cases, the snap-in closure strip is required to complete raceway enclosure.

Metric

Metric dimensions are shown in parentheses. Unless noted, all metric dimensions are in millimeters.



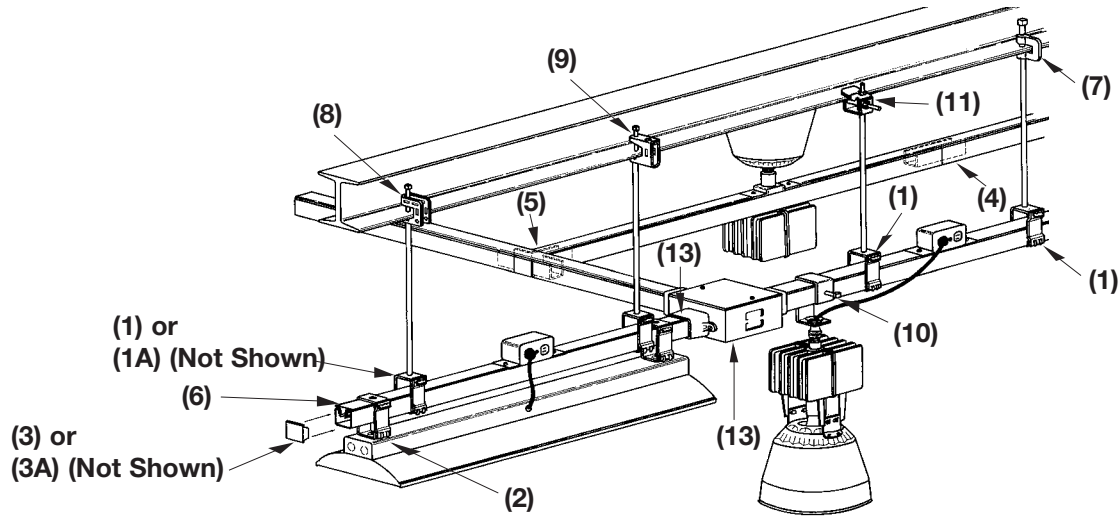

SELECTION CHART

Channel Number	Depth								
		1	1A	2	3	3A	4	5	
		Channel Hanger	Channel Hanger	Fixture Hanger	End Cap	Connection End Cap	Internal Straight Splice	Internal Tee Splice	
B22A	3 1/4" (82.5)	B616-22A*	B241S*	B616S-22A*	B205 or B285	B392-22** B285	B766-22 (2)	B768-22 (2)	
B11	3 1/4" (82.5)	B616-22A*	B241S*	B616S-22A*	B222	B392-11**	B766-11	B768-11	
B12	2 7/16" (61.9)	B616-22A*	B241S*	B616S-22A*	B221	B392-12**	B766-12	B768-12	
B22 B24	1 5/8" (41.3)	B616*	B216S*	B616S* B616TG*	B205 or B285 B223 or B286	B392-22**	B766-22	B768-22	
B26	1 5/8" (41.3)	B616*	-	-	-	B392-22**	-	-	
B32	1 3/8" (34.9)	B616*	B216S*	B616S* B616TG*	B206	B392-32**	B766-32	B768-32	
B42	1" (25.4)	B616*	B215S*	B616S* B616TG*	B203	-	B766-42	B768-42	
B52 B54	1 3/16" (20.6)	B616*	B215S*	B616S* B616TG*	B220 or B283 B204 or B284	-	B766-52	B768-52	
B56	1 3/16" (20.6)	B616*	B215S*	B616S* B616TG*	-	-	B766-56	-	

*Specify Hanger Rod or Conduit Size.

**Specify Conduit Size

OTHER ITEMS SHOWN ON ILLUSTRATION

B217-20 Snap-in Closure Strip (6)	B351L Beam Clamp (7)	B755 Beam Clamp (8)	B751 Beam Clamp (9)
B465 H.I.D. Fixture Hanger (10)	B750 Beam Clamp (11)	B447 B447A Conduit Connection Plate (12)	B719 B718 Series Junction Box (13)

Reference page 162 for general fitting and standard finish specifications. U.L. Wire Fill Chart on pages 230 - 231.

Fluorescent Fixture Hangers

B616-9/16 CHANNEL HANGER

- Design Load 250 Lbs. (1.11 kN)
- Safety Factor of 3
- Maximum design load 50 Lbs. (.22 kN) when used as a fixture support
- Includes:
2 pcs. 3/8" Flat Washers for use with 3/8" ATR
- Material: 16 Gauge (1.5)
- Standard finish: ZN
- Wt./C 25 Lbs. (11.3 kg)

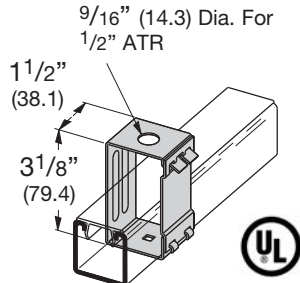

B616-7/8 CHANNEL HANGER

- Design Load 250 Lbs. (1.11 kN)
- Safety Factor of 3
- Maximum design load 50 Lbs. (.22 kN) when used as a fixture support
- Material: 16 Gauge (1.5)
- Standard finish: ZN
- Wt./C 25 Lbs. (11.3 kg)

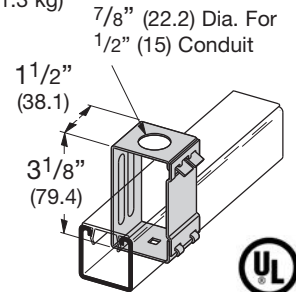

B616S-9/16 FLUORESCENT FIXTURE HANGER WITH STUD

- Design Load 150 Lbs. (.67 kN)
- Safety Factor of 3
- Maximum design load 50 Lbs. (.22 kN) when used as a fixture support
- Allows more than 1/2" (12.7) space between channel and fixture
- Includes:
2 pcs. 3/8" Flat Washers for use with 3/8" ATR
- Material: 16 Gauge (1.5)
- Standard finish: ZN
- Wt./C 30 Lbs. (13.6 kg)

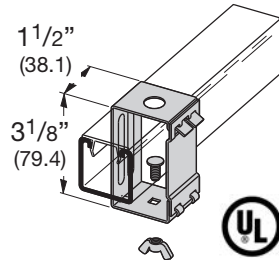

B616S-7/8 FLUORESCENT FIXTURE HANGER WITH STUD

- Design Load 150 Lbs. (.67 kN)
- Safety Factor of 3
- Maximum design load 50 Lbs. (.22 kN) when used as a fixture support
- Allows more than 1/2" (12.7) space between channel and fixture
- Standard finish: ZN
- Wt./C 30 Lbs. (13.6 kg)

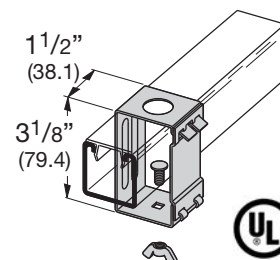

B616-22A-9/16 CHANNEL HANGER

- Design Load 250 Lbs. (1.11 kN)
- Safety Factor of 3
- Maximum design load 50 Lbs. (.22 kN) when used as a fixture support
- Includes:
2 pcs. 3/8" Flat Washers for use with 3/8" ATR
- Material: 14 Gauge (1.9)
- Standard finish: ZN
- Wt./C 44 Lbs. (19.9 kg)

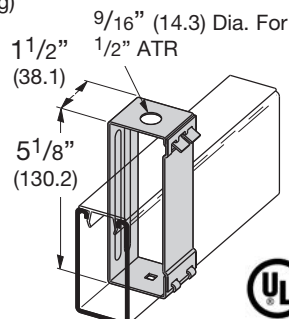

B616-22A-7/8 CHANNEL HANGER

- Design Load 250 Lbs. (1.11 kN)
- Safety Factor of 3
- Maximum design load 50 Lbs. (.22 kN) when used as a fixture support
- Material: 14 Gauge (1.9)
- Standard finish: ZN
- Wt./C 44 Lbs. (19.9 kg)

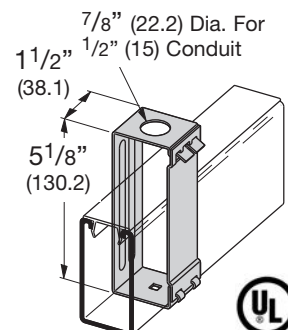

Fluorescent Fixture Hangers

B616S-22A-9/16 FLUORESCENT FIXTURE HANGER WITH STUD

- Design Load 150 Lbs. (.67 kN)
- Safety Factor of 3
- Maximum design load 50 Lbs. (.22 kN) when used as a fixture support
- Includes:
2 pcs. $\frac{3}{8}$ " Flat Washers for use with $\frac{3}{8}$ " ATR
- Allows more than $\frac{1}{2}$ " (12.7) space between channel and fixture
- Material: 14 Gauge (1.9)
- Standard finish: ZN
- Wt./C 49 Lbs. (22.2 kg)

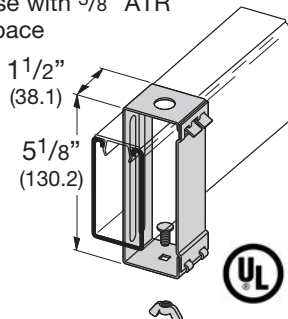

B616S-22A-7/8 FLUORESCENT FIXTURE HANGER WITH STUD

- Design Load 150 Lbs. (.67 kN)
- Safety Factor of 3
- Maximum design load 50 Lbs. (.22 kN) when used as a fixture support
- Allows more than $\frac{1}{2}$ " (12.7) space between channel and fixture
- Material: 14 Gauge (1.9)
- Standard finish: ZN
- Wt./C 49 Lbs. (22.2 kg)

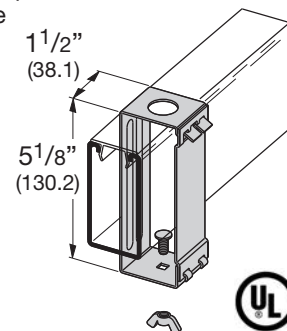

B616TG-9/16 FLUORESCENT FIXTURE HANGER FOR 1/2\" (15) KNOCKOUT

- Design Load 150 Lbs. (.67 kN)
- Safety Factor of 3
- Maximum design load 50 Lbs. (.22 kN) when used as a fixture support
- Includes:
2 pcs. $\frac{3}{8}$ " Flat Washers for use with $\frac{3}{8}$ " ATR
- Design Load 150 Lbs. (.67 kN)
- Allows more than $\frac{1}{2}$ " (12.7) space between channel and fixture
- Material: 16 Gauge (1.5)
- Standard finish: ZN
- Wt./C 32 Lbs. (14.5 kg)

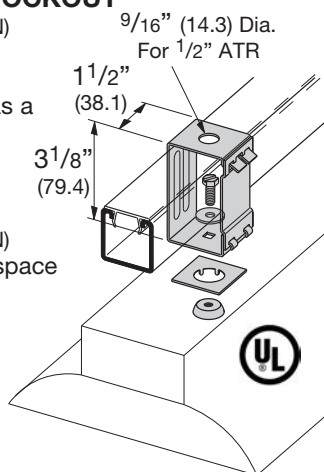

B215S CHANNEL HANGER

- Can be used with $\frac{3}{8}$ " & $\frac{1}{2}$ " threaded rod or $\frac{3}{8}$ " & $\frac{1}{2}$ " conduit
- Design Load 250 Lbs. (1.11 kN)
- Safety Factor of 3
- For use with B42, B52, B54 & B56 Channels
- Hardware included:
One (1) $\frac{3}{8}$ " x $1\frac{1}{2}$ " FFW for use with $\frac{3}{8}$ "-16 ATR
One (1) $\frac{1}{2}$ " FW for use with $\frac{1}{2}$ "-13 ATR
One (1) $\frac{5}{8}$ " FW for use with $\frac{3}{8}$ " conduit
- Material: 16 Gauge (1.5)
- Standard finish: ZN
- Wt./C 31 Lbs. (14.0 kg)

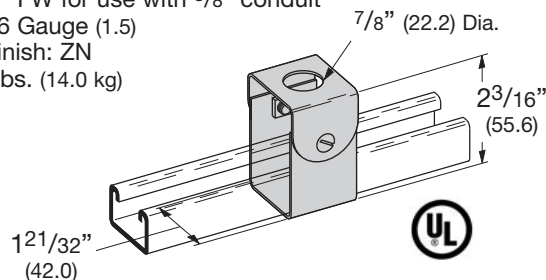

B216S CHANNEL HANGER

- Can be used with $\frac{3}{8}$ " & $\frac{1}{2}$ " threaded rod or $\frac{3}{8}$ " & $\frac{1}{2}$ " conduit
- Design Load 250 Lbs. (1.11 kN)
- Safety Factor of 3
- For use with B22, B24, B26 & B32 Channels
- Hardware included:
One (1) $\frac{3}{8}$ " x $1\frac{1}{2}$ " FFW for use with $\frac{3}{8}$ "-16 ATR
One (1) $\frac{1}{2}$ " FW for use with $\frac{1}{2}$ "-13 ATR
One (1) $\frac{5}{8}$ " FW for use with $\frac{3}{8}$ " conduit
- Material: 16 Gauge (1.5)
- Standard finish: ZN
- Wt./C 38 Lbs. (17.2 kg)

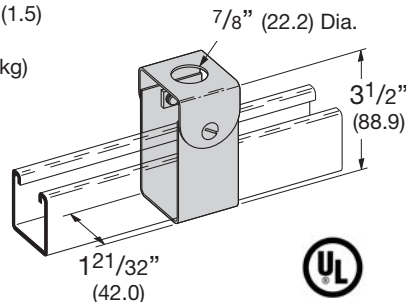

B241S CHANNEL HANGER

- Can be used with $\frac{3}{8}$ " & $\frac{1}{2}$ " threaded rod or $\frac{3}{8}$ " & $\frac{1}{2}$ " conduit
- Design Load 250 Lbs. (1.11 kN)
- Safety Factor of 3
- For use with B11 & B12 Channels
- Hardware included:
One (1) $\frac{3}{8}$ " x $1\frac{1}{2}$ " FFW for use with $\frac{3}{8}$ "-16 ATR
One (1) $\frac{1}{2}$ " FW for use with $\frac{1}{2}$ "-13 ATR
One (1) $\frac{5}{8}$ " FW for use with $\frac{3}{8}$ " conduit
- Material: 16 Gauge (1.5)
- Standard finish: ZN
- Wt./C 47 Lbs. (21.3 kg)

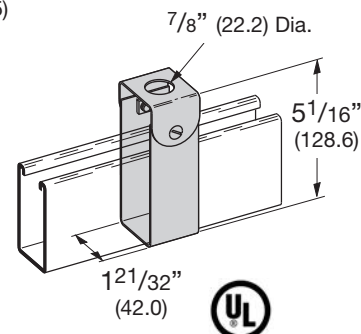

Electrical Accessories

Reference page 162 for general fitting and standard finish specifications. U.L. Wire Fill Chart on pages 230 - 231.

Fluorescent Fixture Hangers

B390S 360° SWIVEL CHANNEL CONNECTOR

- Design Load 250 Lbs. (1.11 kN)
- Safety Factor of 3
- Maximum design load 50 Lbs. (.22 kN) when used as a fixture support
- Swings 15° in 360° plane
- Includes:
 - 2 pcs. SN224-3/4"WO Stud Nut
 - 2 pcs. 1/4"-20 Square Nut
 - 1 pc. 3/4" (20) to 1/2" (15) Conduit Reducer
- Standard finish: ZN
- Wt./C 71 Lbs. (32.2 kg)

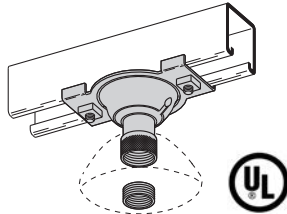

B390BX 360° SWIVEL BOX CONNECTOR

- Design Load 250 Lbs. (1.11 kN) for Connector Fitting only
- Safety Factor of 3
- Design Load 50 Lbs. (.22 kN) when used as illustrated or for use as a fixture support
- Swings 15° in 360° plane
- Includes:
 - 1 pc. 3/4" (20) to 1/2" (15) Conduit Reducer
- Fits on 4" box
- Standard finish: ZN
- Wt./C 55 Lbs. (24.9 kg)

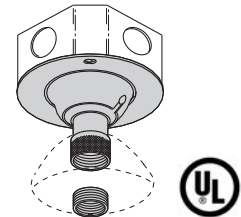

B465 H.I.D. FIXTURE HANGER

- Design Load 250 Lbs. (1.11 kN)
- Safety Factor of 3
- Swings 15° in 360° plane
- Includes:
 - 1 pc. 3/4" (20) to 1/2" (15) Conduit Reducer
- Standard finish: ZN
- Wt./C 95 Lbs. (43.1 kg)

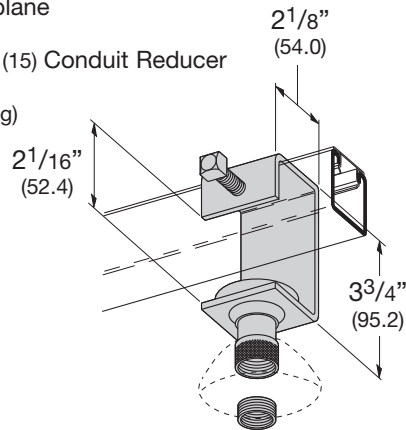

B436 FLUORESCENT FIXTURE NUT

- Standard finish: ZN
- Wt./C 2 Lbs. (.9 kg)

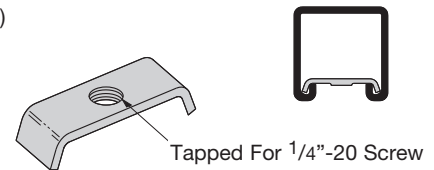

B436S FLUORESCENT FIXTURE STUD NUT

- Bolt size: 1/4" x 1 1/4"
- Standard finish: ZN
- Wt./C 4 Lbs. (1.8 kg)
- Design Load 250 Lbs. (1.11 kN)
- Safety Factor of 3

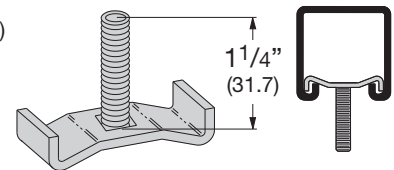

B460 FLUORESCENT FIXTURE HANGER

- Hanger is shipped flat and requires field bending as shown
- Allows more than 1/2" (12.7) space between channel and fixture
- Material: 18 Gauge (1.2)
- Standard finish: ZN

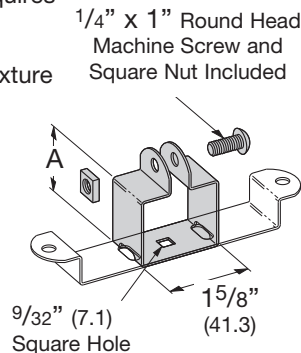

B464 FLUORESCENT FIXTURE HANGER

- Hanger is shipped flat and requires field bending as shown
- Allows more than 1/8" (3.2) space between channel and fixture
- Material: 18 Gauge (1.2)
- Standard finish: ZN

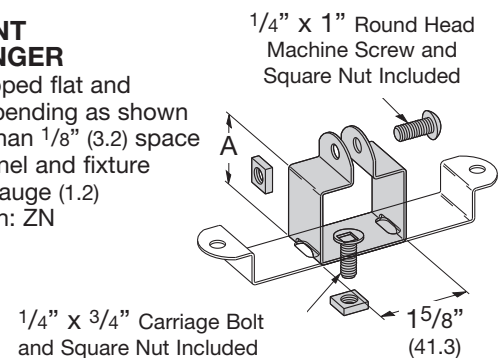

Part No.	For Channel Size	A		Wt./C	
		Lbs.	kg	Lbs.	kg
B460-22	B22, B24, B26, B32	2 1/8"	(57.5)	17	(7.7)
B460-12	B12	2 15/16"	(79.5)	20	(9.1)
B460-11	B11	3 3/4"	(101.6)	23	(10.4)

Part No.	For Channel Size	A		Wt./C	
		Lbs.	kg	Lbs.	kg
B464-32	B32	1 1/2"	(40.6)	17	(7.7)
B464-22	B22, B24, B26	1 3/4"	(47.4)	18	(8.1)
B464-12	B12	2 9/16"	(66.0)	21	(9.5)
B464-11	B11	3 3/8"	(91.4)	24	(10.9)

Electrical Accessories

B217-20 SNAP CLOSURE STRIP FOR ALL 1 5/8" (41.3) WIDE CHANNELS

- Refer to Raceway Fill Chart Pg. 214-215
- Material: 20 Gauge (.9)
- Standard finishes: GRN, GALV, YZN
- Standard length: 120" (3.05m)
- Wt./CFT 36 Lbs. (16.3 kg)

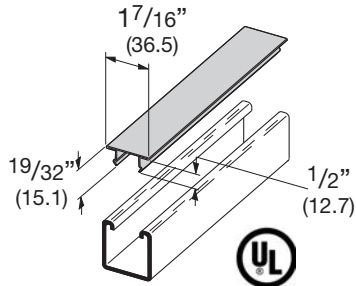

B217P PLASTIC SNAP CLOSURE STRIP FOR ALL 1 5/8" (41.3) WIDE CHANNELS

- Refer to Raceway Fill Chart Pg. 214-215
- Standard finishes: Green (GRN) or Gray (GRY) Plastic
- Standard length: 120" (3.05m)
- Wt./CFT 9.2 Lbs. (4.2 kg)

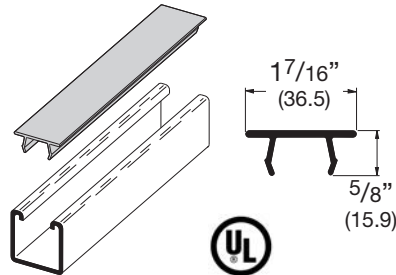

B217-24 SNAP CLOSURE STRIP FOR ALL 1 5/8" (41.3) WIDE CHANNELS

- Refer to Raceway Fill Chart Pg. 214-215
- For use with 7 or fewer conductors no larger than #12 AWG
- Material: 24 Gauge (.6)
- Standard finishes: GRN, GALV, YZN
- Standard length: 120" (3.05m)
- Wt./CFT 28 Lbs. (12.7 kg)

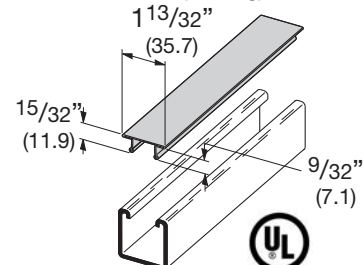

B516 SNAP-IN OUTLET BOX

- Provided with #10-32 tapped hole for grounding strap
- Duplex cover plate included
- Receptacle not furnished
- Requires ground wire installation for use with UL listed channel raceway system
- Standard finish: GALV
- Wt./C 72 Lbs. (32.6 kg)

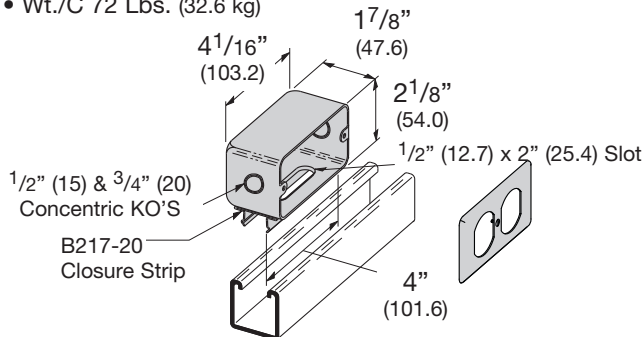

B516S OUTLET BOX

- Duplex cover plate included
- Receptacle not furnished
- Includes:
2 pcs. 1/4"-20 Flat Head Machine Screws
2 pcs. N224WO Channel Nuts
- Standard finish: ZN
- Wt./C 98 Lbs. (44.4 kg)

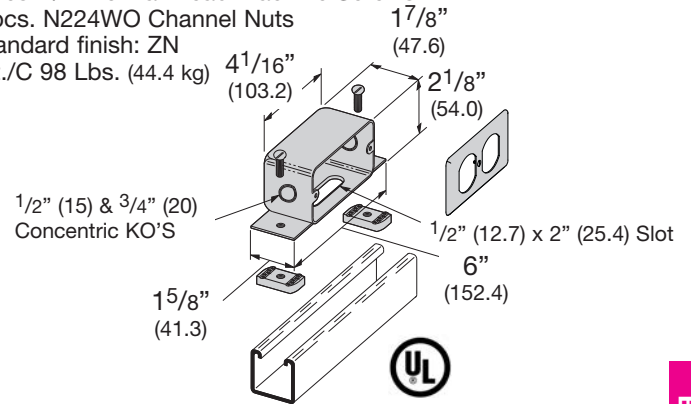

B203 THRU B206 B220 THRU B223 X TYPE END CAPS

- Material: 12 Gauge (2.6)
- Standard finishes: ZN, GRN, HDG, SS4

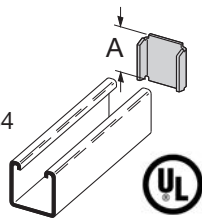

Part No.	Use With	A	Wt./C	
			Lbs.	kg
B203	B42	1.015" (25.8)	6	(2.7)
B204	B54	.827" (21.0)	5	(2.2)
B205	B22	1.640" (41.6)	10	(4.5)
B206	B32	1.390" (35.3)	8	(3.6)
B220	B52	.827" (21.0)	4	(1.8)
B221	B12	2.452" (62.3)	15	(6.8)
B222	B11	3.265" (82.9)	20	(9.1)
B223	B24	1.640" (41.6)	10	(4.5)

B283 THRU B286 END CAPS

- Material: 12 Gauge (2.6)
- Standard finishes: ZN, GRN

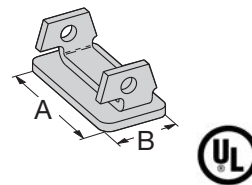

Part No.	Use With	A		B		Wt./C	
		Lbs.	kg	Lbs.	kg	Lbs.	kg
B283	B52	1 19/32" (40.5)		25/32" (19.8)		6	(2.7)
B284	B54 & B56	1 19/32" (40.5)		25/32" (19.8)		6	(2.7)
B285	B22	1 19/32" (40.5)		1 19/32" (40.5)		13	(5.9)
B286	B24 & B26	1 19/32" (40.5)		1 19/32" (40.5)		14	(6.3)

Reference page 162 for general fitting and standard finish specifications. U.L. Wire Fill Chart on pages 230 - 231.

Electrical Accessories

B447 CONDUIT CONNECTION PLATE FOR 1/2" (15) CONDUIT

- Includes:
 - 2 pcs. 1/4"-20 Flat Head Machine Screws
 - 2 pcs. N224WO Channel Nuts
- Material: 16 Gauge (1.5)
- Standard finish: ZN
- Wt./C 35 Lbs. (15.9 kg)

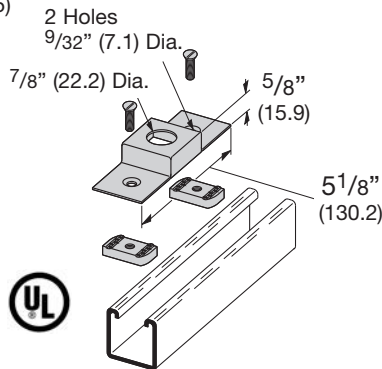

B447A CONDUIT CONNECTION PLATE FOR 3/4" (20) CONDUIT

- Includes:
 - 2 pcs. 1/4"-20 Flat Head Machine Screws
 - 2 pcs. N224WO Channel Nuts
- Material: 16 Gauge (1.5)
- Standard finish: ZN
- Wt./C 35 Lbs. (15.9 kg)

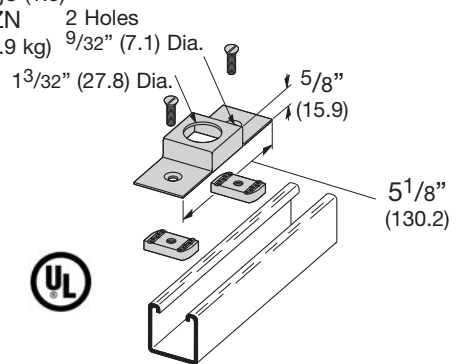

B392-32 SERIES CONNECTION END CAP

- Includes:
 - 1 pc. 1/4"-20 Square Nut
 - 1 pc. B436S Fixture Stud Nut
- Material: 11 Gauge (3.0)
- Standard finish: ZN

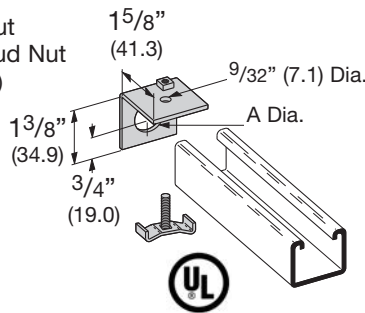

B392-22 SERIES CONNECTION END CAP

- Includes:
 - 1 pc. 1/4"-20 Square Nut
 - 1 pc. B436S Fixture Stud Nut
- Material: 11 Gauge (3.0)
- Standard finish: ZN

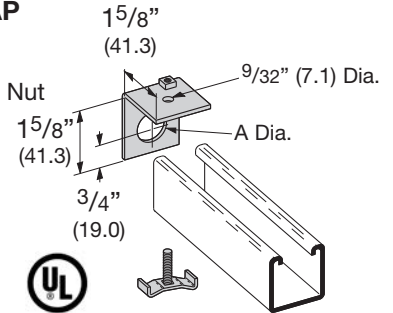

Part No.	A		Conduit Size		Wt./C	
					Lbs.	kg
B392-32-1/2	7/8"	(22.2)	1/2"	(15)	20	(9.1)
B392-32-3/4	1 1/16"	(27.0)	3/4"	(20)	19	(8.6)

Part No.	A		Conduit Size		Wt./C	
					Lbs.	kg
B392-22-1/2	7/8"	(22.2)	1/2"	(15)	21	(9.5)
B392-22-3/4	1 1/16"	(27.0)	3/4"	(20)	20	(9.1)
B392-22-1	1" PIPE THREAD		1"	(25)	17	(7.7)

B392-12 SERIES CONNECTION END CAP

- Includes:
 - 1 pc. 1/4"-20 Square Nut
 - 1 pc. B436S Fixture Stud Nut
- Material: 11 Gauge (3.0)
- Standard finish: ZN

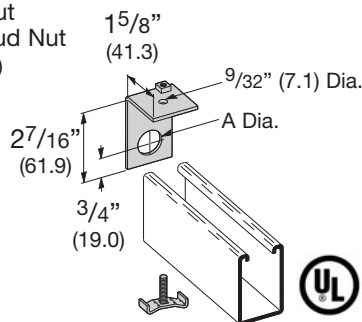

B392-11 SERIES CONNECTION END CAP

- Includes:
 - 1 pc. 1/4"-20 Square Nut
 - 1 pc. B436S Fixture Stud Nut
- Material: 11 Gauge (3.0)
- Standard finish: ZN

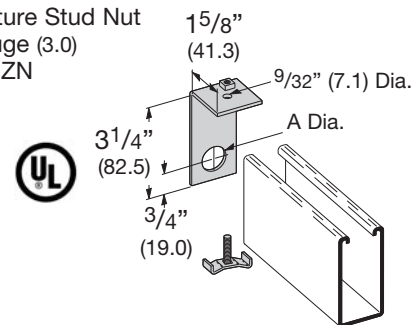

Part No.	A		Conduit Size		Wt./C	
					Lbs.	kg
B392-12-1/2	7/8"	(22.2)	1/2"	(15)	27	(12.2)
B392-12-3/4	1 1/16"	(22.7)	3/4"	(20)	26	(11.8)
B392-12-1	1" PIPE THREAD		1"	(25)	23	(10.4)

Part No.	A		Conduit Size		Wt./C	
					Lbs.	kg
B392-11-1/2	7/8"	(22.2)	1/2"	(15)	36	(16.3)
B392-11-3/4	1 1/16"	(27.0)	3/4"	(20)	33	(14.9)
B392-11-1	1" PIPE THREAD		1"	(25)	32	(14.5)

Electrical Accessories

Reference page 162 for general fitting and standard finish specifications. U.L. Wire Fill Chart on pages 230 - 231.

B718 UNIVERSAL JUNCTION BOX

- Assemble B719 Hubs into B718 square knockouts
- Designed for use with B22, B24 & B26 Channel
- B718 Includes:
 - 1 pc. Junction Box only
 - 1 pc. Cover only
 - 2 pcs. #10-20 Round Head Machine Screws
- Standard finish: ZN
- Wt./C 180 Lbs. (81.6 kg)

Part No.	Includes	Wt./C	
		Lbs.	kg
B718-1	1 B718 & 1 B719	205	(93.0)
B718-2	1 B718 & 2 B719	230	(104.3)
B718-3	1 B718 & 3 B719	255	(115.6)
B718-4	1 B718 & 4 B719	280	(127.0)

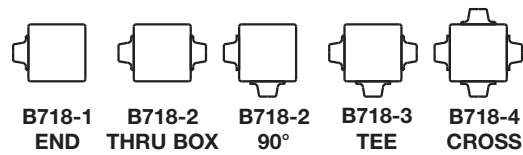

SELECTION GUIDE

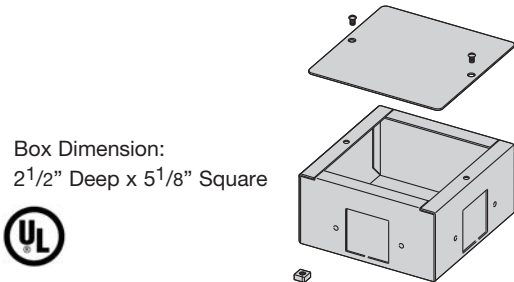

Box Dimension:
2 1/2" Deep x 5 1/8" Square



B719AL UNIVERSAL JUNCTION BOX HUB

- B719AL Includes:
 - 1 pc. B719AL Hub only
 - 1 pc. B436S Fixture Stud Nut
 - 1 pc. 1/4"-20 Square Nut
 - 2 pcs. #10-24 Self Tapping Screws
 - 2 pcs. Rubber Caps
- Material: Aluminum
- Wt./C 25 Lbs. (11.3 kg)

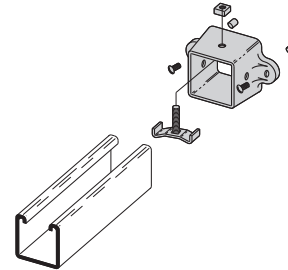

B518-1 THRU B518-4 UNIVERSAL JUNCTION BOX AND HUBS

- Channel Connection Kits as shown in the chart above
- Includes:
 - 1 pc. Junction Box with Screws
 - 1 pc. Box Cover
- Standard finish: ZN

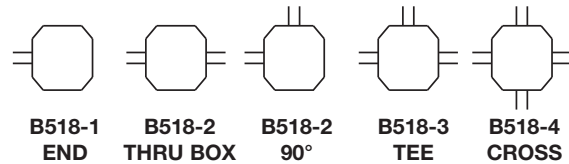

SELECTION GUIDE

Part No.	Channel Connection Kits Included	Wt./C	
		Lbs.	kg
B518-1	1	106	(48.1)
B518-2	2	137	(62.1)
B518-3	3	162	(78.5)
B518-4	4	192	(87.1)

CHANNEL CONNECTION KIT

- For use with B22, B24 & B26 Channels.
- Box Dimension: Standard 4" Octagon Box
- Includes:
 - 1 pc. B392-22-3/4 End Connection (See page 160)
 - 1 pc. 3/4" (20) Insulated Chase Nipple
 - 1 pc. 3/4" (20) Lock Nut
- Standard finish: ZN

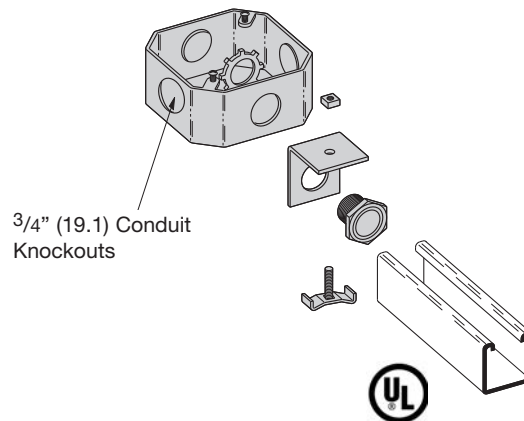

3/4" (19.1) Conduit Knockouts



Strut Joiners

B766 SERIES STRAIGHT STRUT JOINER

- Includes: 2 Cam Screws
- Material: 12 Gauge (2.6)
- Standard finish: ZN

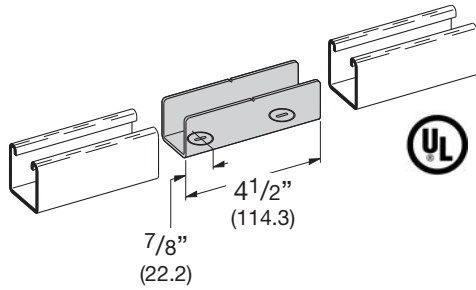

Part No.	For Channel Size	Wt./C	
		Lbs.	kg
B766-11	B11	94	(42.6)
B766-12	B12	72	(32.6)
B766-22 *	B22 & B24	50	(22.7)
B766-26	B26	53	(24.0)
B766-32	B32	44	(19.9)
B766-42	B42	34	(15.4)
B766-52	B52 & B54	28	(12.7)
B766-56	B56	31	(14.0)

B767 SERIES 90° ELBOW STRUT JOINER

- Includes: 2 Cam Screws
- Material: 12 Gauge (2.6)
- Standard finish: ZN

Note: B767-22
(Cast Aluminum Fitting)
does not require miter
cutting of channel as
shown in drawing.

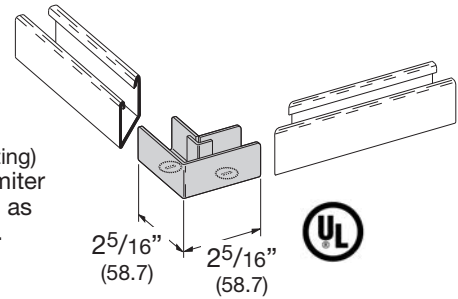

Part No.	For Channel Size	Wt./C	
		Lbs.	kg
B767-11	B11	74	(33.5)
B767-12	B12	56	(25.4)
B767-22 *	B22 & B24	39	(17.7)
B767-26	B26	41	(18.6)
B767-32	B32	34	(15.4)
B767-42	B42	27	(12.2)
B767-52	B52 & B54	23	(10.4)
B767-56	B56	25	(11.3)

B768 SERIES TEE STRUT JOINER

- Includes: 3 Cam Screws
- Patented
- Material: 12 Gauge (2.6)
- Standard finish: ZN

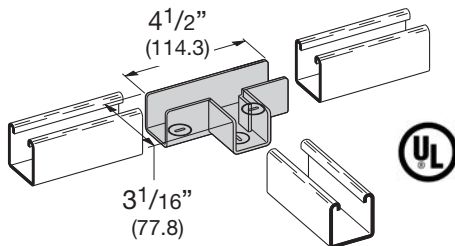

Part No.	For Channel Size	Wt./C	
		Lbs.	kg
B768-11	B11	142	(64.4)
B768-12	B12	112	(50.8)
B768-22 *	B22 & B24	79	(35.8)
B768-26	B26	79	(35.8)
B768-32	B32	72	(32.6)
B768-42	B42	62	(28.1)
B768-52	B52 & B54	57	(25.8)
B768-56	B56	60	(27.2)

* Cast Aluminum parts

B769 SERIES CROSS STRUT JOINER

- Includes: 4 Cam Screws
- Patented
- Material: 12 Gauge (2.6)
- Standard finish: ZN

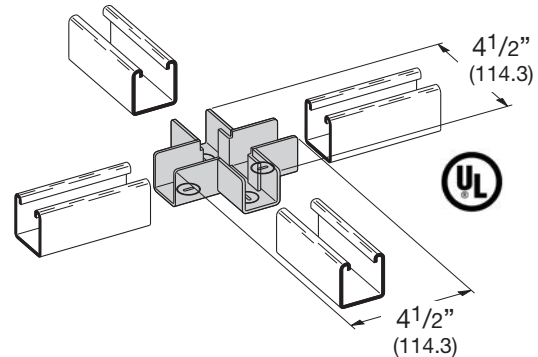

Part No.	For Channel Size	Wt./C	
		Lbs.	kg
B769-11	B11	148	(67.1)
B769-12	B12	120	(54.4)
B769-22 *	B22 & B24	87	(39.4)
B769-26	B26	93	(42.2)
B769-32	B32	78	(35.4)
B769-42	B42	65	(29.5)
B769-52	B52 & B54	58	(26.3)
B769-56	B56	62	(28.1)

Note: Strut joiners are not for structural support. A channel support is recommended within 24" (609 mm) of each joint.

B166 FOUR HOLE SPLICE CLEVIS

- Includes:
1 Splice Clevis
4 pcs. 1/4"-20 Flat Head Machine Screws
4 pcs. N224WO Channel Nuts
- Material: 16 Gauge (1.5)
- Standard finishes: ZN, GRN

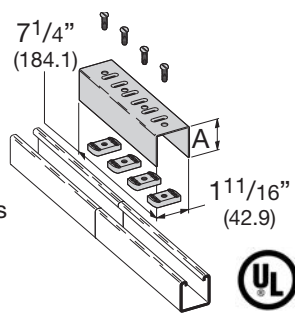

B166-46 FOUR HOLE SPLICE CLEVIS ASSEMBLY

- Requires ground wire for use with UL listed channel raceway system
- Includes:
1 Splice Clevis
1 pc. B466W tapped plate
4 pcs. 1/4"-20 Flat Head Machine Screws
- Material: 16 Gauge (1.5)
- Standard finishes: ZN, GRN

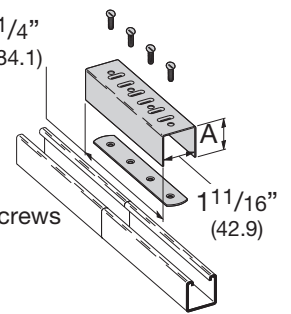

Part No.	A		For Channel Size	Wt./C	
				Lbs.	kg
B166-11	3 1/4"	(82.5)	B11	128	(58.0)
B166-12	2 7/16"	(61.9)	B12	108	(49.0)
B166-22	1 5/8"	(41.3)	B22, B24, B26	91	(40.3)
B166-32	1 3/8"	(34.9)	B32	83	(37.6)
B166-42	1"	(25.4)	B42	75	(34.0)
B166-52	1 3/16"	(20.6)	B52, B54, B56	71	(32.2)

Part No.	A		For Channel Size	Wt./C	
				Lbs.	kg
B166-46-11	3 1/4"	(82.5)	B11	118	(53.5)
B166-46-12	2 7/16"	(61.9)	B12	98	(44.4)
B166-46-22	1 5/8"	(41.3)	B22, B24, B26	79	(35.8)
B166-46-32	1 3/8"	(34.9)	B32	73	(33.1)
B166-46-42	1"	(25.4)	B42	65	(29.5)
B166-46-52	1 3/16"	(20.6)	B52, B54, B56	61	(27.6)

B166CL SPLICE CLEVIS CLIP

- Use to cover gap between strut
- Material: 18 Gauge (1.2)
- Standard finish: ZN
- Wt./C 4 Lbs. (1.8 kg)

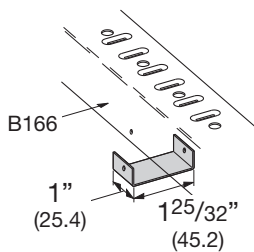

B466W TAPPED SPLICE PLATE

- Includes:
4 pcs. 1/4"-20 Flat Head Machine Screws
- Material: 14 Gauge (1.9)
- Standard finish: ZN
- Wt./C 27 Lbs. (12.2 kg)
- Holes 1 3/16" (20.6) from ends and 1 7/8" (47.6) on centers

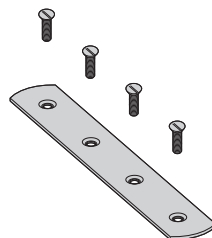

B466S STUD SPLICE PLATE

- Includes:
4 pcs. 1/4"-20 Square Nuts
- Material: 14 Gauge (1.9)
- Standard finish: ZN
- Wt./C 34 Lbs. (15.4 kg)
- Studs 1 3/16" (20.6) from ends and 1 7/8" (47.6) on centers

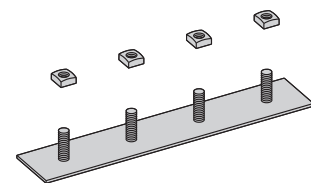

B619 KNOCK-OUT PLATE

- Requires ground wire for use with UL listed channel raceway system
- Includes:
2 pcs. 1/4"-20 Flat Head Machine Screws
2 pcs. N224WO Channel Nuts
- Material: 16 Gauge (1.5)
- 1/2" (15) Conduit Knockouts
- Standard finish: ZN
- Wt./C 40 Lbs. (18.1 kg)

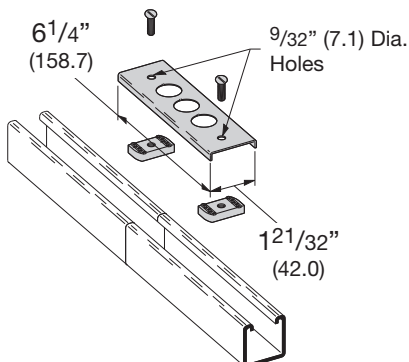

B393-1 WIRING STUD

- Requires ground wire for use with UL listed channel raceway system
- 1/2" (15) pipe threads
- Material: Cast Aluminum
- Wt./C 6 Lbs. (2.7 kg)

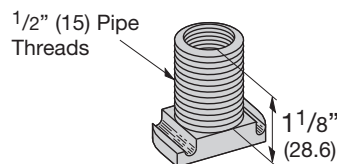

B589 SPACER CLEVIS

- Can be used with B393-1 wiring stud
- Material: 12 Gauge (2.6)
- Standard finish: ZN
- Wt./C 29 Lbs. (13.1 kg)

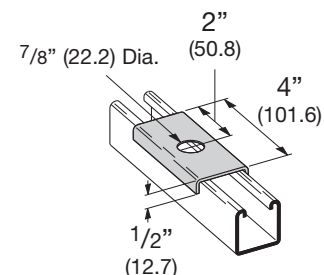

Reference page 162 for general fitting and standard finish specifications. U.L. Wire Fill Chart on pages 230 - 231.

B446A SWIVEL HANGER (FEMALE ONLY)

- Design Load:
(³/₈)-610 Lbs. (2.71 kN)
(¹/₂)-1130 Lbs. (5.02 kN)
- Safety Factor of 3
- Standard finish: ZN

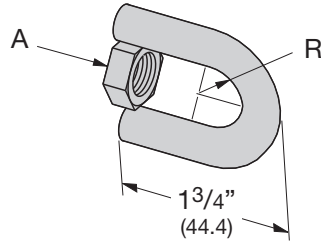

Part No.	A	R	Wt./C	
			Lbs.	kg
B446A- ³ / ₈	³ / ₈ "-16 HN	⁹ / ₃₂ " (7.1)	13	(5.9)
B446A- ¹ / ₂	¹ / ₂ "-13 HN	³ / ₈ " (9.5)	15	(6.8)

B446B SWIVEL HANGER (MALE ONLY)

- Design Load:
(³/₈)-610 Lbs. (2.71 kN)
(¹/₂)-1130 Lbs. (5.02 kN)
- Safety Factor of 3
- Standard finish: ZN

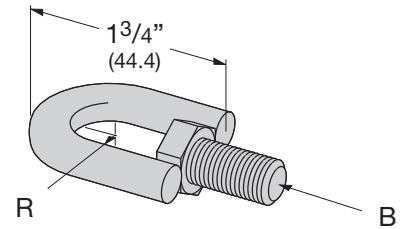

Part No.	A	R	Wt./C	
			Lbs.	kg
B446B- ³ / ₈	³ / ₈ "-16 HHCS	⁹ / ₃₂ " (7.1)	16	(7.2)
B446B- ¹ / ₂	¹ / ₂ "-13 HHCS	³ / ₈ " (9.5)	20	(9.1)

B446C SWIVEL HANGER (FEMALE-FEMALE)

- Design Load:
(³/₈)-610 Lbs. (2.71 kN)
(¹/₂)-1130 Lbs. (5.02 kN)
- Safety Factor of 3
- Standard finish: ZN

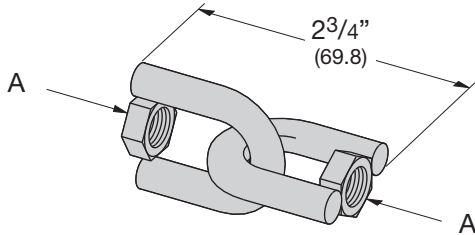

Part No.	A	Wt./C	
		Lbs.	kg
B446C- ³ / ₈	³ / ₈ "-16 HN	26	(11.8)
B446C- ¹ / ₂	¹ / ₂ "-13 HN	31	(14.0)

B446 SWIVEL HANGER (FEMALE-MALE)

- Design Load:
(³/₈)-610 Lbs. (2.71 kN)
(¹/₂)-1130 Lbs. (5.02 kN)
- Safety Factor of 3
- Standard finish: ZN

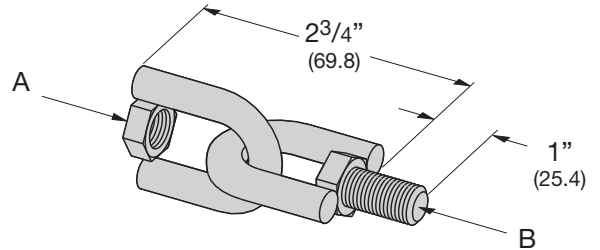

Part No.	A	B	Wt./C	
			Lbs.	kg
B446- ³ / ₈	³ / ₈ "-16 HN	³ / ₈ "-16 HHCS	28	(12.7)
B446- ¹ / ₂	¹ / ₂ "-13 HN	¹ / ₂ "-13 HHCS	36	(16.3)

B590 FIBER WIRE RETAINER

- Installation aid for retaining wires before installing snap closure strip
- Wt./C 1 Lb. (.4 kg)

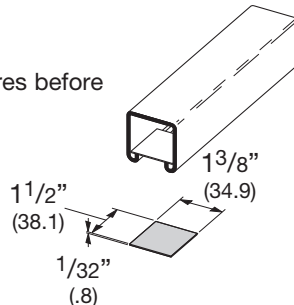

B617 SHOULDER BOLT

- Standard finish: ZN
- Wt./C 6 Lbs. (2.7 kg)

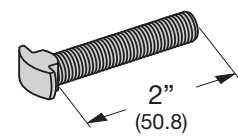

³/₈"-16 Thread Size

B4060 THRU B4093

INSULCLAMP CABLE CLAMPS (Replaces porcelain clamps)

- Assembly includes:
 - 1 Insulclamp & 1 pr. zinc plated Pipe Straps with Everdur (Silicon Bronze) Hardware
- The thermoplastic elastomer Insulclamp has a dielectric strength of 640 volts/mil
- The flame retardant one piece design allows for trouble free assembly
- Everdur hardware is non-ferrous and prevents magnetic induction

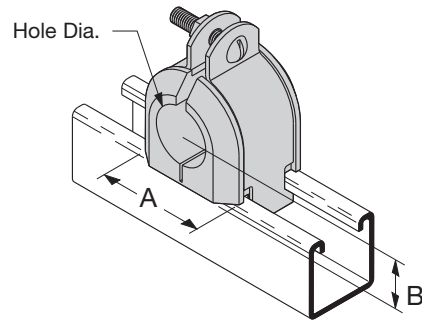

Part No.	Hole Dia.		Wt./C		A		B		Includes Clamp No.
			Lbs.	kg					
B4060	3/8"	(9.5)	25	(11.3)	1.36"	(34.5)	.56"	(14.2)	B2030
B4061	1/2"	(12.7)	25	(11.3)					
B4062	5/8"	(15.9)	25	(11.3)					
B4063	3/4"	(19.0)	37	(16.8)	1.86"	(47.2)	.81"	(20.8)	B2011
B4064	7/8"	(22.2)	37	(16.8)					
B4065	1"	(25.4)	37	(16.8)					
B4066	1 1/8"	(28.6)	37	(16.8)					
B4067	1 1/4"	(31.7)	58	(26.3)	2.36"	(59.9)	1.06"	(26.9)	B2038
B4068	1 3/8"	(34.9)	58	(26.3)					
B4069	1 1/2"	(38.1)	58	(26.3)					
B4070	1 5/8"	(41.3)	58	(26.3)					
B4071	1 3/4"	(44.4)	76	(34.5)	2.86"	(72.6)	1.31"	(33.3)	B2042
B4072	1 7/8"	(47.6)	76	(34.5)					
B4073	2"	(50.8)	76	(34.5)					
B4074	2 1/8"	(54.0)	76	(34.5)					
B4075	2 1/4"	(57.1)	90	(40.8)	3.36"	(85.3)	1.56"	(39.6)	B2046
B4076	2 3/8"	(60.3)	90	(40.8)					
B4077	2 1/2"	(63.5)	90	(40.8)					
B4078	2 5/8"	(66.7)	90	(40.8)					
B4079	2 3/4"	(69.8)	109	(49.4)	3.86"	(98.0)	1.81"	(46.0)	B2050
B4080	2 7/8"	(73.0)	109	(49.4)					
B4081	3"	(76.2)	109	(49.4)					
B4082	3 1/8"	(79.4)	109	(49.4)					
B4083	3 1/4"	(82.5)	130	(58.9)	4.36"	(110.7)	2.06"	(52.3)	B2054
B4084	3 3/8"	(85.7)	130	(58.9)					
B4085	3 1/2"	(88.9)	130	(58.9)					
B4086	3 5/8"	(92.1)	130	(58.9)					
B4087	3 3/4"	(95.2)	160	(72.6)	4.86"	(123.4)	2.31"	(58.7)	B2058
B4088	3 7/8"	(98.4)	160	(72.6)					
B4089	4"	(101.6)	160	(72.6)					
B4090	4 1/8"	(104.8)	160	(72.6)					
B4091	4 1/4"	(107.9)	160	(72.6)	5.24"	(133.1)	2.50"	(63.5)	B2018
B4092	4 3/8"	(111.1)	160	(72.6)					
B4093	4 1/2"	(114.3)	160	(72.6)					

Reference page 162 for general fitting and standard finish specifications. U.L. Wire Fill Chart on pages 230 - 231.

Reference page 162 for general fitting and standard finish specifications. U.L. Wire Fill Chart on pages 230 - 231.

Porcelain & Maple Clamps

B4050 & B4051 PORCELAIN CABLE CHANNEL SADDLE

- Electrical porcelain has an dielectric strength of 50 volts/mil

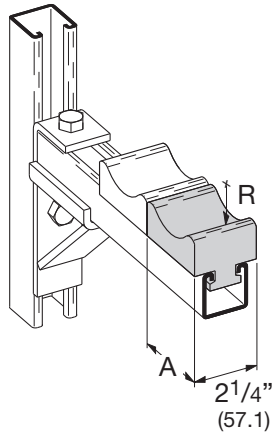

Part No.	A		R		Wt./C	
	Lbs.	kg	Lbs.	kg	Lbs.	kg
B4050	3"	(76.2)	1 ³ / ₈ "	(34.9)	72	(32.6)
B4051	4"	(101.6)	2 ¹ / ₈ "	(54.0)	100	(45.3)

B4094 & B4095 PORCELAIN CABLE RACK SADDLE

- Electrical porcelain has an dielectric strength of 50 volts/mil
- Designed for use with B449 Brackets

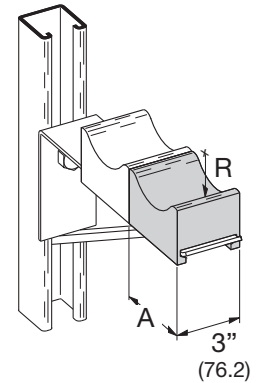

Part No.	A		R		Wt./C	
	Lbs.	kg	Lbs.	kg	Lbs.	kg
B4094	2 ⁷ / ₈ "	(73.0)	1 ³ / ₈ "	(34.9)	67	(30.4)
B4095	3 ⁷ / ₈ "	(98.4)	2 ¹ / ₈ "	(54.0)	106	(48.1)

B4035A THRU B4035F 4" (101.6) BUS BAR MAPLE CLAMPS

- Assembly Includes:
 - 1 pr. Maple Clamps (Paraffin Impregnated)
 - 3 pcs. 1/2" Flat Washers
 - 3 pcs. N225WO
 - 3 pcs. SQN-1/2"
 - 3 pcs. ATR-1/2 x L (Length)
- Required number of Separators
 - 1/4" (6.3) x 2" (50.8) and 1/4" (6.3) x 6" (152.4)
- Bus Bar Maple Clamps available

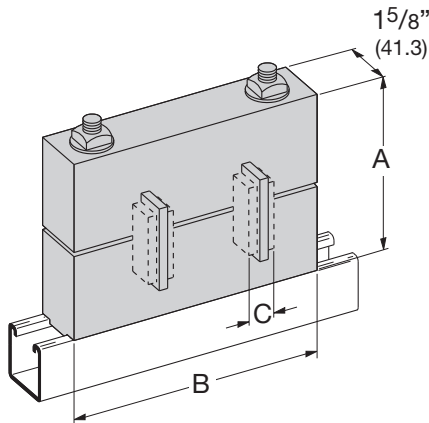

B4037B 1/4" (6.3) x 4" (101.6) BUS BAR SEPARATOR

- Wt./C 9 Lbs. (4.1 kg)

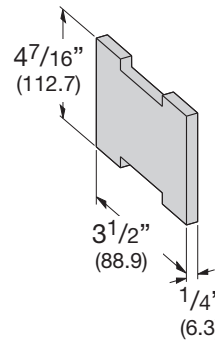

Part No.	A		B		C		No. of Bus Separators	No. of Bars Per Leg	Wt./C	
	Lbs.	kg	Lbs.	kg	Lbs.	kg			Lbs.	kg
B4035A	7 ³ / ₈ "	(187.3)	8 ¹ / ₂ "	(215.9)	1/4"	(6.3)	–	1	416	(188.7)
B4035B			9 ¹ / ₂ "	(241.3)	3/4"	(19.0)	2	2	447	(202.7)
B4035C			10 ¹ / ₂ "	(266.7)	1 ¹ / ₄ "	(31.7)	4	3	479	(217.3)
B4035D			11 ¹ / ₂ "	(292.1)	1 ³ / ₄ "	(44.4)	6	4	511	(231.8)
B4035E			12 ¹ / ₂ "	(317.5)	2 ¹ / ₄ "	(57.1)	8	5	542	(245.8)
B4035F			13 ¹ / ₂ "	(342.9)	2 ³ / ₄ "	(69.8)	10	6	574	(260.3)

Electrical Accessories

B4000 THRU B4007 MAPLE CABLE CLAMPS

- Assembly Includes:
 - 1 pr. Maple Clamps (Paraffin Impregnated)
 - 1 pr. zinc plated Steel Pipe Straps with Everdur Hardware (Silicon Bronze)
- Everdur hardware is non-ferrous and prevents magnetic induction

Note: Maple cable clamps may be replaced with Insulclamps™ see page 173 for sizes

Part No.	Specify Hole Dia.		A		B		Clamp No. (included)	Wt./C	
								Lbs.	kg
B4000	0" to 5/8"	(0.0 to 15.9)	1 11/32"	(34.1)	2"	(50.8)	B2010	24	(10.9)
B4001	1/2" to 1"	(12.7 to 25.4)	1 29/32"	(48.4)	2 25/32"	(70.6)	B2012	44	(19.9)
B4002	3/4" to 1 1/2"	(19.0 to 38.1)	2 3/8"	(60.3)	3 9/32"	(83.3)	B2013	58	(26.3)
B4003	1 1/4" to 1 3/4"	(31.7 to 44.4)	2 7/8"	(73.0)	3 3/4"	(95.2)	B2014	66	(29.9)
B4004	1 1/2" to 2 1/4"	(38.1 to 57.1)	3 1/2"	(88.9)	4 3/8"	(111.1)	B2015	86	(39.0)
B4005	2" to 2 1/2"	(50.8 to 63.5)	4"	(101.6)	4 7/8"	(123.8)	B2016	110	(49.9)
B4006	2 1/4" to 3"	(38.1 to 76.2)	4 1/2"	(114.3)	5 3/8"	(136.5)	B2017	125	(56.7)
B4007	3" to 4"	(76.2 to 101.6)	5 9/16"	(141.3)	6 7/16"	(163.5)	B2019	165	(74.8)

Specify Hole Dia.

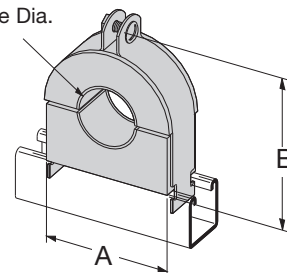

B4008 THRU B4017 SQUARE MAPLE CABLE SADDLE

- Assembly Includes:
 - 1 Maple Saddle (Paraffin Impregnated)
 - 1 pc. 3/8"-16 Flat Head Machine Screw
 - 1 pc. N228 Channel Nut
- Other sizes available

Part No.	Specify Hole Dia.		A		B		Wt./C	
							Lbs.	kg
B4008	0" to 1"	(0.0 to 25.4)	3"	(76.2)	1 3/4"	(44.4)	35	(15.9)
B4009	1" to 1 1/2"	(25.4 to 38.1)	3 1/2"	(88.9)	2"	(50.8)	42	(19.0)
B4010	1 1/2" to 2"	(38.1 to 50.8)	4"	(101.6)	2 1/4"	(57.1)	53	(24.0)
B4011	2" to 2 1/2"	(50.8 to 63.5)	4 1/2"	(114.3)	2 1/2"	(63.5)	62	(28.1)
B4012	2 1/2" to 3"	(63.5 to 76.2)	5"	(127.0)	2 3/4"	(69.8)	76	(34.5)
B4013	3" to 3 1/2"	(76.2 to 88.9)	5 1/2"	(139.7)	3"	(76.2)	85	(38.5)
B4014	3 1/2" to 4"	(88.9 to 101.6)	6"	(152.4)	3 1/4"	(82.5)	95	(43.1)
B4015	4" to 4 1/2"	(101.6 to 114.3)	7"	(177.8)	3 3/4"	(95.2)	105	(47.8)
B4016	4 1/2" to 5"	(114.3 to 127.0)	7 1/2"	(190.5)	4"	(101.6)	115	(52.4)
B4017	5" to 6"	(127.0 to 152.4)	9"	(228.6)	5"	(127.0)	126	(57.1)

Specify Hole Dia.

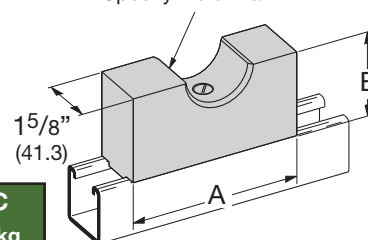

B4033A THRU B4033I MAPLE CABLE CLAMPS

- Assembly Includes:
 - 1 pr. Maple Clamps (Paraffin Impregnated)
 - 2 pcs. 3/8"-16 Stud Bolts
 - 2 pcs. 3/8"-16 Flat Washers
 - 2 pcs. 3/8"-16 Square Nuts
 - 2 pcs. N228 Channel Nuts
- Other sizes available

Part No.	Specify Hole Dia.		A		Wt./C	
					Lbs.	kg
B4033A	0" to 1"	(0.0 to 25.4)	3 1/2"	(88.9)	85	(38.5)
B4033B	1" to 1 1/2"	(25.4 to 38.1)	4"	(101.6)	95	(43.1)
B4033C	1 1/2" to 2"	(38.1 to 50.8)	4 1/2"	(114.3)	118	(53.5)
B4033D	2" to 2 1/2"	(50.8 to 63.5)	5 1/2"	(127.0)	162	(73.5)
B4033E	2 1/2" to 3"	(63.5 to 76.2)	6"	(152.4)	187	(84.8)
B4033F	3" to 3 1/2"	(76.2 to 88.9)	6 1/2"	(165.1)	209	(94.8)
B4033G	3 1/2" to 4"	(88.9 to 101.6)	7"	(177.8)	248	(112.5)
B4033H	4" to 4 1/2"	(101.6 to 114.3)	7 1/2"	(190.5)	270	(122.5)
B4033I	4 1/2" to 5"	(114.3 to 127.0)	8"	(203.2)	298	(135.2)

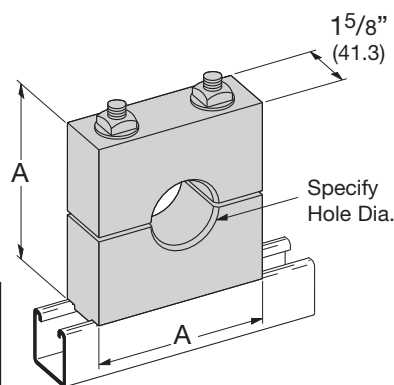

Aluminum & Stainless Steel

Aluminum

Aluminum channels, fittings and accessories offer excellent corrosion resistance and are suitable for many indoor and outdoor applications. Aluminum's high strength to weight ratio greatly reduces overall cost of installation through ease of handling and cutting. Channels are extruded from aluminum alloy 6063-T6. Closure strips are extruded from aluminum alloy 6063-T5. Fittings and accessories are made from aluminum alloy 5052-H32.

Stainless Steel

Where corrosion problems persist and other material and fittings are ineffective, we recommend use of corrosion resistant stainless steel channels and accessories. Channels and fittings are available in two types of stainless steel:

SS4-AISI Type 304

SS6-AISI Type 316

Fittings

Most fittings, as shown in this catalog, can be supplied in aluminum or stainless steel. Consult factory for possible minimum production quantities and set-up charges.

Load Data

Aluminum

Channel's approximate load data can be determined by multiplying load data in the steel channel section of this catalog by a factor of 0.38.

Stainless Steel

Channel load data is the same as the data in the steel channel section of this catalog.

Metric

Metric dimensions are shown in parentheses. Unless noted, all metric dimensions are in millimeters.

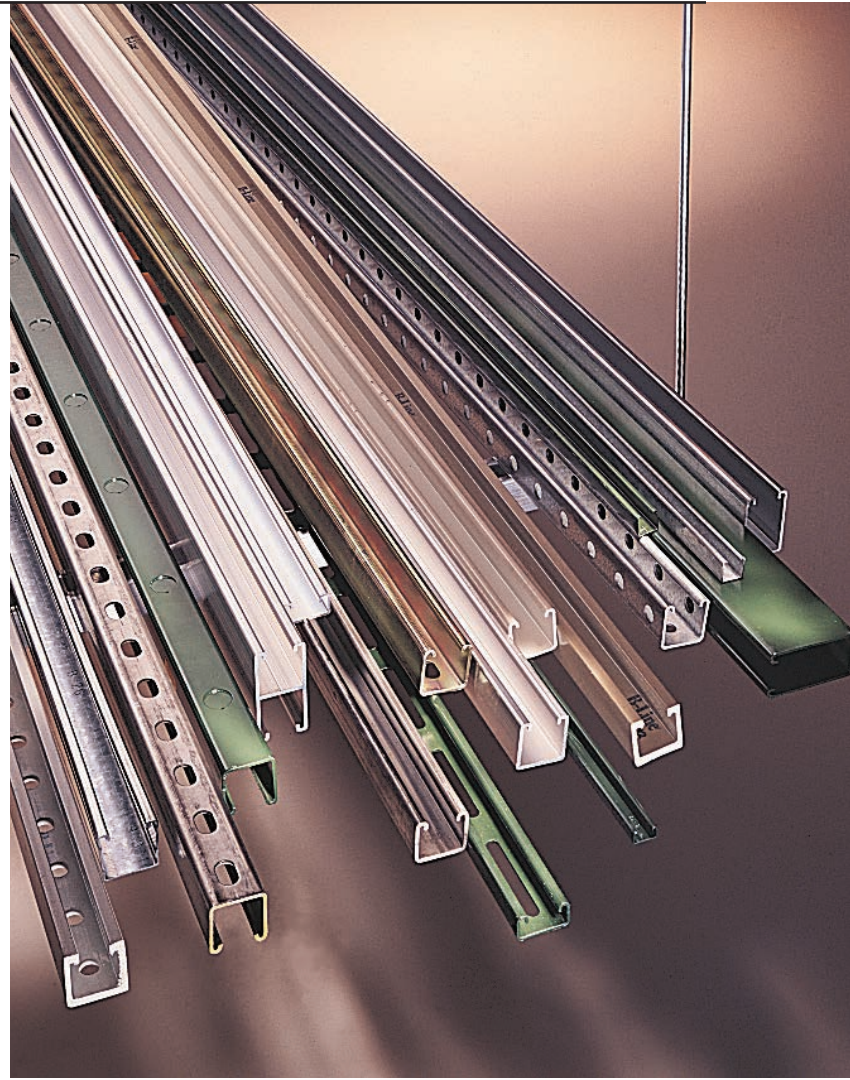

Aluminum Channel & Closure Strips

B11AL

- Thickness: .105 (2.6 mm)
- Standard Length: 10' (3.05 m) and 20' (6.09 m)
- Material: Aluminum
- Weight: 1.06 Lbs./Ft. (1.58 kg/m)

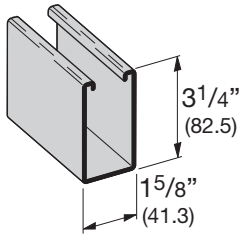

B12AL

- Thickness: .105 (2.6 mm)
- Standard Length: 10' (3.05 m) and 20' (6.09 m)
- Material: Aluminum
- Weight: .86 Lbs./Ft. (1.28 kg/m)

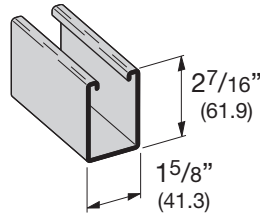

B22AL

- Thickness: .105 (2.6 mm)
- Standard Length: 10' (3.05 m) and 20' (6.09 m)
- Material: Aluminum
- Weight: .66 Lbs./Ft. (0.98 kg/m)

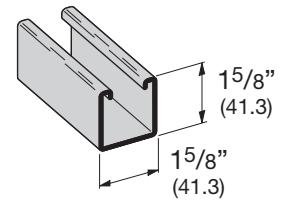

B22AAL

- Thickness: .105 (2.6 mm)
- Standard Length: 10' (3.05 m) and 20' (6.09 m)
- Material: Aluminum
- Weight: 1.18 Lbs./Ft. (1.75 kg/m)

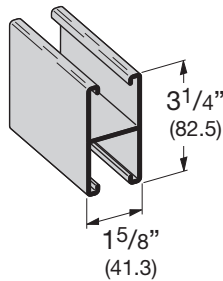

B24AL

- Thickness: .080 (2.0 mm)
- Standard Length: 10' (3.05 m) and 20' (6.09 m)
- Material: Aluminum
- Weight: .52 Lbs./Ft. (0.77 kg/m)

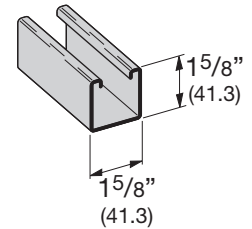

B54AL

- Thickness: .080 (2.0 mm)
- Standard Length: 10' (3.05 m) and 20' (6.09 m)
- Material: Aluminum
- Weight: .37 Lbs./Ft. (0.55 kg/m)

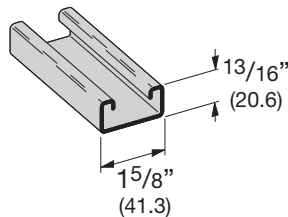

B54AAL

- Thickness: .080 (2.0 mm)
- Standard Length: 10' (3.05 m) and 20' (6.09 m)
- Material: Aluminum
- Weight: .57 Lbs./Ft. (0.84 kg/m)

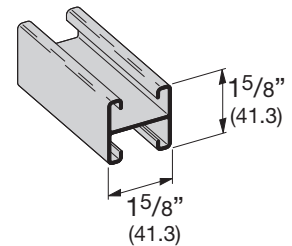

B217AL CLOSURE STRIP

- Standard Length: 10' (304.8 cm)
- Material: Aluminum
- Weight: .15 Lbs./Ft. (0.23 kg/m)

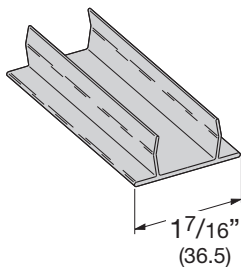

B217P PLASTIC CLOSURE STRIP

- Standard Length: 10' (304.8 cm)
- Material: PVC
- Weight: .09 Lbs./Ft. (0.14 kg/m)

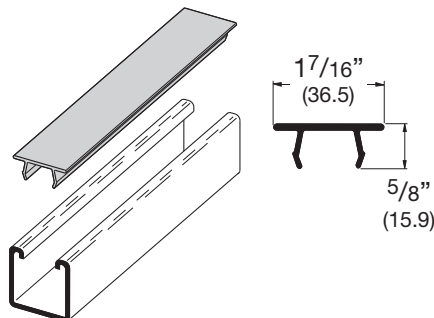

B217FFAL CLOSURE STRIP

- Standard Length: 10' (304.8 cm)
- Material: Aluminum
- Weight: .16 Lbs./Ft. (0.24 kg/m)

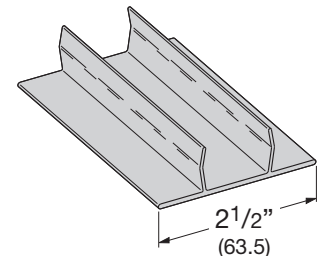

Reference page 176 for general fitting specifications. Other channel combinations available—see steel section for styles.

Aluminum

SH TYPE CHANNEL

- Material: Aluminum

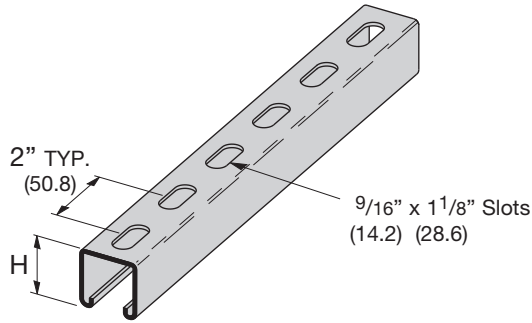

Part No.	Thickness		H		Wt./C	
	Lbs.	kg/m	Lbs.	kg/m	Lbs./Ft.	kg/m
B12SH AL	.105	(2.6)	2 ⁷ / ₁₆ "	(61.9)	.83	(1.23)
B22SH AL	.105	(2.6)	1 ⁵ / ₈ "	(41.3)	.63	(.93)
B24SH AL	.080	(2.0)	1 ⁵ / ₈ "	(41.3)	.49	(.73)
B54SH AL	.080	(2.0)	1 ³ / ₁₆ "	(20.6)	.34	(.50)

H-17/8 TYPE CHANNEL

- Material: Aluminum

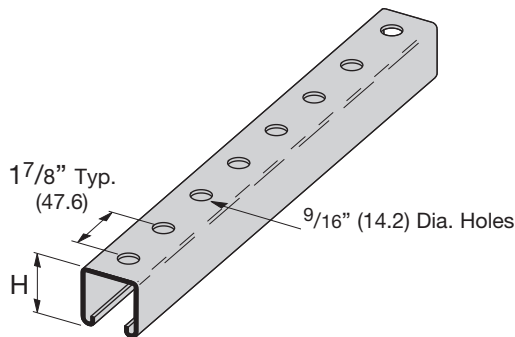

Part No.	Thickness		H		Wt./C	
	Lbs.	kg/m	Lbs.	kg/m	Lbs./Ft.	kg/m
B12H17/8 AL	.105	(2.6)	2 ⁷ / ₁₆ "	(61.9)	.86	(1.28)
B22H17/8 AL	.105	(2.6)	1 ⁵ / ₈ "	(41.3)	.66	(.98)
B24H17/8 AL	.080	(2.0)	1 ⁵ / ₈ "	(41.3)	.52	(.77)
B54H17/8 AL	.080	(2.0)	1 ³ / ₁₆ "	(20.6)	.37	(.55)

KO6 TYPE KNOCKOUT CHANNEL

- Material: Aluminum

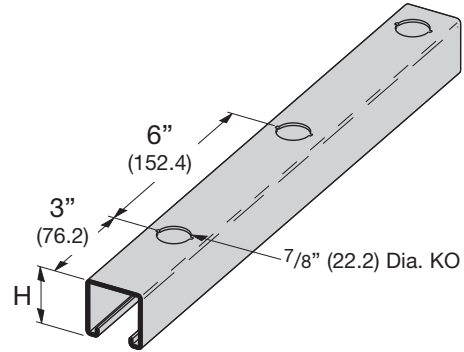

Part No.	Thickness		H		Wt./C	
	Lbs.	kg/m	Lbs.	kg/m	Lbs./Ft.	kg/m
B12KO6 AL	.105	(2.6)	2 ⁷ / ₁₆ "	(61.9)	.86	(1.28)
B22KO6 AL	.105	(2.6)	1 ⁵ / ₈ "	(41.3)	.66	(.98)
B24KO6 AL	.080	(2.0)	1 ⁵ / ₈ "	(41.3)	.52	(.77)
B54KO6 AL	.080	(2.0)	1 ³ / ₁₆ "	(20.6)	.37	(.55)

B2000 SERIES RIGID CONDUIT CLAMPS

- Safety Factor of 5
- Machine Screw and Square Nut included
- Pipe clamp material 5052-H32

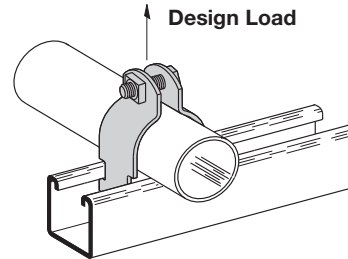

Part No.	Conduit or Pipe Size		Material Thickness		Design Load		Wt./C	
	Lbs.	mm	Lbs.	mm	Lbs.	kN	Lbs.	kg
B2001 AL	3/8"	(10)	.063	(1.6)	180	(.80)	4	(1.8)
B2008 AL	1/2"	(15)	.063	(1.6)	180	(.80)	4	(1.8)
B2009 AL	3/4"	(20)	.080	(2.0)	270	(1.20)	6	(2.7)
B2010 AL	1"	(25)	.080	(2.0)	270	(1.20)	7	(3.2)
B2011 AL	1 1/4"	(32)	.080	(2.0)	270	(1.20)	8	(3.6)
B2012 AL	1 1/2"	(40)	.100	(2.5)	360	(1.60)	11	(5.0)
B2013 AL	2"	(50)	.100	(2.5)	360	(1.60)	12	(5.4)
B2014 AL	2 1/2"	(65)	.100	(2.5)	360	(1.60)	13	(5.9)
B2015 AL	3"	(80)	.100	(2.5)	360	(1.60)	16	(7.2)
B2016 AL	3 1/2"	(90)	.125	(3.2)	450	(2.00)	22	(10.0)
B2017 AL	4"	(100)	.125	(3.2)	450	(2.00)	24	(10.9)
B2018 AL	4 1/2"	(115)	.125	(3.2)	450	(2.00)	26	(11.8)
B2019 AL	5"	(125)	.125	(3.2)	450	(2.00)	27	(12.2)
B2020 AL	6"	(150)	.125	(3.2)	450	(2.00)	33	(14.9)

ALUMINUM FITTINGS

Most fittings, as shown in this catalog, can be supplied in aluminum. See "Fittings" section (page 72) of this catalog. Consult factory for possible minimum production quantities and set-up charges.

CHANNEL NUTS

We recommend the use of Stainless Steel channel nuts with Aluminum channel. For channel nut pull-out strength and slip resistance, use the channel nut information provided on pg. 50 & 51. A (.70) multiplier is to be applied to obtain the appropriate derated values for aluminum channel.

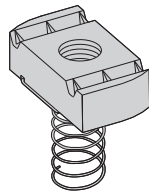

SPRING NUT

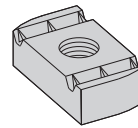

NUT WITHOUT SPRING

NUTS FOR B12 CHANNEL

Part Number		Thread Size	Thickness		Wt./C	
With Spring	Without Spring				Lbs.	kg
N724SS6	N224WOSS6	1/4"-20	1/4"	(6.3)	6.6	(3.0)
N728SS6	N228WOSS6	3/8"-16	3/8"	(9.5)	10.6	(4.8)
N725SS6	N225WOSS6	1/2"-13	3/8"	(9.5)	9.7	(4.4)

NUTS FOR B22, B24 CHANNELS

Part Number		Thread Size	Thickness		Wt./C	
With Spring	Without Spring				Lbs.	kg
N224SS6	N224WOSS6	1/4"-20	1/4"	(6.3)	6.6	(3.0)
N228SS6	N228WOSS6	3/8"-16	3/8"	(9.5)	10.6	(4.8)
N225SS6	N225WOSS6	1/2"-13	3/8"	(9.5)	9.7	(4.4)

NUTS FOR B54 CHANNEL

Part Number		Thread Size	Thickness		Wt./C	
With Spring	Without Spring				Lbs.	kg
N524SS6	N224WOSS6	1/4"-20	1/4"	(6.3)	6.6	(3.0)
N528SS6	N228WOSS6	3/8"-16	3/8"	(9.5)	10.6	(4.8)
N525SS6	N525WOSS6	1/2"-13	3/8"	(9.5)	9.7	(4.4)

Reference page 176 for general fitting specifications. Other channel combinations available-see steel section for styles.

Stainless Steel

B22SS*

- *Substitute 4 for Stainless Steel Type 304 or 6 for Stainless Steel Type 316
- Thickness: 12 Ga. (2.6 mm)
- Standard Length: 10' (3.05 m) and 20' (6.09 m)
- Material: SS4, SS6
- Weight: 1.90 Lbs./Ft. (2.83 kg/m)

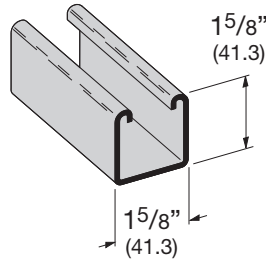

B24SS*

- *Substitute 4 for Stainless Steel Type 304 or 6 for Stainless Steel Type 316
- Thickness: 14 Ga. (1.9 mm)
- Standard Length: 10' (3.05 m) and 20' (6.09 m)
- Material: SS4, SS6
- Weight: 1.40 Lbs./Ft. (2.08 kg/m)

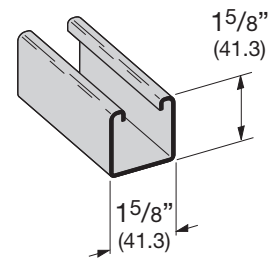

B32SS4

- Thickness: 12 Ga. (2.6 mm)
- Standard Length: 10' (3.05 m) and 20' (6.09 m)
- Material: SS4
- Weight: 1.70 Lbs./Ft. (2.53 kg/m)

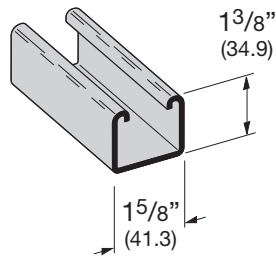

B42SS4

- Thickness: 12 Ga. (2.6 mm)
- Standard Length: 10' (3.05 m) and 20' (6.09 m)
- Material: SS4
- Weight: 1.44 Lbs./Ft. (2.14 kg/m)

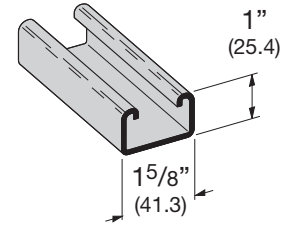

B52SS*

- *Substitute 4 for Stainless Steel Type 304 or 6 for Stainless Steel Type 316
- Thickness: 12 Ga. (2.6 mm)
- Standard Length: 10' (3.05 m) and 20' (6.09 m)
- Material: SS4, SS6
- Weight: 1.27 Lbs./Ft. (1.89 kg/m)

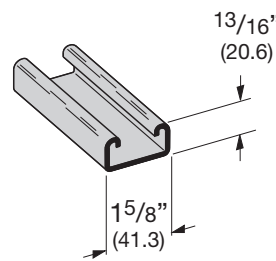

B54SS*

- *Substitute 4 for Stainless Steel Type 304 or 6 for Stainless Steel Type 316
- Thickness: 14 Ga. (1.9 mm)
- Standard Length: 10' (3.05 m) and 20' (6.09 m)
- Material: SS4, SS6
- Weight: .97 Lbs./Ft. (1.44 kg/m)

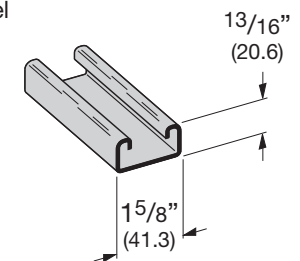

SH TYPE CHANNEL

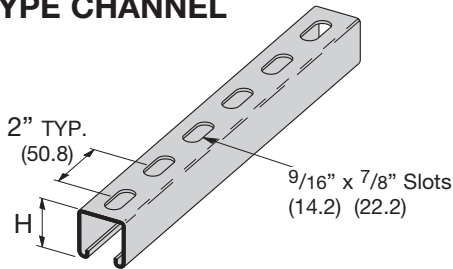

H-17/8 TYPE CHANNEL

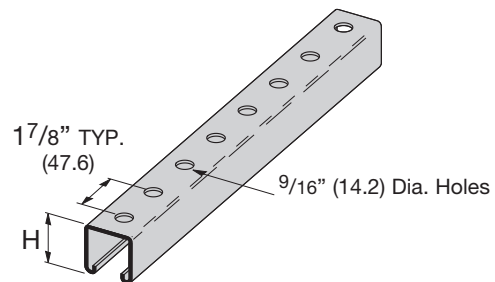

Part No.	Thickness	H	Wt./C Lbs./Ft. kg/m
B22SH SS4	12 Ga. (2.6)	1 5/8" (41.3)	1.82 (2.70)
B22SH SS6	12 Ga. (2.6)	1 5/8" (41.3)	1.82 (2.70)
B24SH SS4	14 Ga. (1.9)	1 5/8" (41.3)	1.34 (1.99)
B24SH SS6	14 Ga. (1.9)	1 5/8" (41.3)	1.34 (1.99)
B32SH SS4	12 Ga. (2.6)	1 3/8" (34.9)	1.62 (2.41)
B42SH SS4	12 Ga. (2.6)	1" (25.4)	1.36 (2.02)
B52SH SS4	12 Ga. (2.6)	1 3/16" (20.6)	1.23 (1.83)
B52SH SS6	12 Ga. (2.6)	1 3/16" (20.6)	1.23 (1.83)
B54SH SS4	14 Ga. (1.9)	1 3/16" (20.6)	.91 (1.35)
B54SH SS6	14 Ga. (1.9)	1 3/16" (20.6)	.91 (1.35)

Part No.	Thickness	H	Wt./C Lbs./Ft. kg/m
B22H17/8 SS4	12 Ga. (2.6)	1 5/8" (41.3)	1.85 (2.75)
B24H17/8 SS4	14 Ga. (1.9)	1 5/8" (41.3)	1.36 (2.02)
B24H17/8 SS6	14 Ga. (1.9)	1 5/8" (41.3)	1.36 (2.02)
B32H17/8 SS4	12 Ga. (2.6)	1 3/8" (34.9)	1.65 (2.45)
B42H17/8 SS4	12 Ga. (2.6)	1" (25.4)	1.39 (2.07)
B54H17/8 SS4	14 Ga. (1.9)	1 3/16" (20.6)	.93 (1.38)
B54H17/8 SS6	14 Ga. (1.9)	1 3/16" (20.6)	.93 (1.38)

STAINLESS STEEL FITTINGS

Most fittings, as shown in this catalog, can be supplied in Type 304 or Type 316 stainless steel. See "Fittings" section (page 72) of this catalog.
 Consult factory for possible minimum production quantities and set-up charges.

B2000 SERIES PIPE AND TUBING CLAMPS

- Safety Factor of 5
- Combination Recess Hex Head Machine Screw and Square Nut included
- Material: Stainless Steel Type 304 & 316

Part No.	Conduit Pipe Size	Material Thickness	Design Load		Wt./C	
			Lbs.	kN	Lbs.	kg
B2001 SS4	3/8" (10)	16 Ga. (1.5)	400	(1.78)	10	(4.5)
B2008 SS4	1/2" (15)	16 Ga. (1.5)	400	(1.78)	11	(5.0)
B2009 SS4	3/4" (20)	14 Ga. (1.9)	600	(2.67)	15	(6.8)
B2010 SS4	1" (25)	14 Ga. (1.9)	600	(2.67)	16	(7.2)
B2011 SS4	1 1/4" (32)	14 Ga. (1.9)	600	(2.67)	20	(9.1)
B2012 SS4	1 1/2" (40)	12 Ga. (2.6)	800	(3.56)	30	(13.6)
B2013 SS4	2" (50)	12 Ga. (2.6)	800	(3.56)	34	(15.4)
B2014 SS4	2 1/2" (65)	12 Ga. (2.6)	800	(3.56)	38	(17.2)
B2015 SS4	3" (80)	12 Ga. (2.6)	800	(3.56)	44	(19.9)
B2016 SS4	3 1/2" (90)	12 Ga. (2.6)	1000	(4.45)	51	(23.1)
B2017 SS4	4" (100)	12 Ga. (2.6)	1000	(4.45)	55	(24.9)
B2018 SS4	4 1/2" (115)	12 Ga. (2.6)	1000	(4.45)	59	(26.7)
B2019 SS4	5" (125)	12 Ga. (2.6)	1000	(4.45)	64	(29.0)
B2020 SS4	6" (150)	12 Ga. (2.6)	1000	(4.45)	80	(36.3)

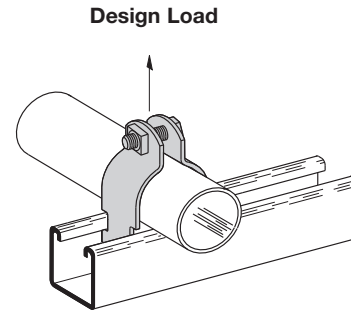

CHANNEL NUTS

- For Channel Nuts pull-out strength and slip resistance, use the data shown in "Channel Nuts & Hardware" section of this catalog.

Note: Reduce slip load by 50% due to hardness of material.

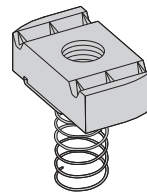

SPRING NUT

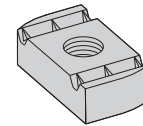

NUT WITHOUT SPRING

NUTS FOR B22, B24, B32 CHANNELS

Part Number		Thread Size	Thickness		Wt./C	
With Spring	Without Spring				Lbs.	kg
N224SS6	N224WOSS6	1/4"-20	1/4"	(6.3)	6.6	(3.0)
N228SS6	N228WOSS6	3/8"-16	3/8"	(9.5)	10.6	(4.8)
N225SS6	N225WOSS6	1/2"-13	3/8"	(9.5)	9.7	(4.4)

NUTS FOR B42, B52, B54 CHANNELS

Part Number		Thread Size	Thickness		Wt./C	
With Spring	Without Spring				Lbs.	kg
N524SS6	N224WOSS6	1/4"-20	1/4"	(6.3)	6.6	(3.0)
N528SS6	N228WOSS6	3/8"-16	3/8"	(9.5)	10.6	(4.8)
N525SS6	N225WOSS6	1/2"-13	3/8"	(9.5)	9.7	(4.4)

Reference page 176 for general fitting specifications. Other channel combinations available—see steel section for styles.

Fiberglass

We offer two fire retardant (FR) resins for strut systems, polyester and vinyl ester. Both resins are ideal for corrosive environments.

While polyester is sufficient for most uses, vinyl ester is suitable for a broader range of environments.

Please refer to the "Corrosion Resistance Guide" for specific applications, page 183.

Materials & Finishes

Our Fiberglass Strut systems are manufactured from glass fiber-reinforced plastic shapes that meet ASTM E-84, Class 1 Flame Rating and self-extinguishing requirements of ASTM D-635. A surface veil is applied during pultrusion to insure a resin-rich surface and ultraviolet resistance.

Fittings

The following dimensions apply to all fittings except as noted on the drawings:

Hole Size— $13/32$ " (10.3 mm) Dia.

Hole Spacing— $13/16$ " (20.6 mm) from end and $17/8$ " (47.6 mm) on center.

Width— $15/8$ " (41.3 mm)

Thickness— $1/4$ " (6.3 mm)

Metric

Metric dimensions are shown in parentheses. Unless noted, all metric dimensions are in millimeters.



CHANNEL RESIN INFORMATION

We offer two fire retardant (FR) resins for strut systems, polyester and vinyl ester. Both resins are ideal for corrosive environments. While polyester is sufficient for most uses, vinyl ester is suitable for a broader range of environments.

Please refer to the "Corrosion Resistance Guide" below for specific applications.

Corrosion Resistance Guide					
Chemicals	70°F (21°C)	160°F (71°C)	Chemicals	70°F (21°C)	160°F (71°C)
Acetic acid 5%	BFP/BFV	BFP/BFV	Methyl alcohol 10%	BFP/BFV	BFV-150° **
Acetic acid 52%	BFP/BFV	BFV-210° **	Naphtha	BFP/BFV	BFP/BFV
Aluminum potassium sulfate 5%	BFP/BFV	BFP/BFV	Nitric acid 5%	BFP/BFV	BFP/BFV
Ammonium hydroxide 10%	BFP/BFV	BFV-150° **	Nitric acid 20%	BFV	BFV-120° **
Ammonium nitrate	BFP/BFV	BFP/BFV	Phosphoric acid 10%	BFP/BFV	BFP/BFV
Benzene sulfonic acid 5%	BFP/BFV	BFP/BFV	Phosphoric acid 30%	BFP/BFV	BFP/BFV
Calcium chloride	BFP/BFV	BFP/BFV	Phosphoric acid 85%	BFP/BFV	BFP/BFV
Carbon tetrachloride	BFV	BFV-100° **	Sodium bicarbonate 10%	BFP/BFV	BFP/BFV
Chlorine dioxide 15%	BFP/BFV	BFV-150° **	Sodium bisulfate	BFP/BFV	BFP/BFV
Chromic acid 5%	BFV	BFV-150° **	Sodium carbonate	BFP/BFV	BFV
Copper sulfate	BFP/BFV	BFP/BFV	Sodium chloride	BFP/BFV	BFP/BFV
Diesel fuel	BFP/BFV	BFV	Sodium hydroxide 1-50%	BFV	BFV-120° **
Ethylene glycol	BFP/BFV	BFP/BFV	Sodium hypochlorite 5%	BFP/BFV	BFV-120° **
Fatty acids 100%	BFP/BFV	BFP/BFV	Sodium nitrate	BFP/BFV	BFP/BFV
Ferrous sulfate	BFP/BFV	BFP/BFV	Sodium silicate	BFP/BFV	BFV-210° **
Fluosilicic acid 0-20%	BFV	BFV	Sodium sulfate	BFP/BFV	BFP/BFV
Gasoline	BFP/BFV	BFV	Sulfuric acid 0-30%	BFP/BFV	BFP/BFV
Hydrochloric acid 1%	BFP/BFV	BFP/BFV	Sulfuric acid 30-50%	BFV	BFV
Hydrochloric acid 15%	BFP/BFV	BFV-180° **	Sulfuric acid 50-70%	BFV	BFV-180° **
Hydrochloric acid 37%	BFP/BFV	BFV-150° **	Trisodium phosphate 25%	BFP/BFV	BFV-210° **
Kerosene	BFP/BFV	BFP/BFV	Trisodium phosphate-All	BFV	BFV-210° **
Magnesium chloride	BFP/BFV	BFP/BFV	Water, Distilled	BFP/BFV	BFP/BFV

BFP - BFP parts recommended BFV - BFV parts recommended ** - Not recommended to exceed this temperature

Information contained in this chart is based on data from raw material suppliers.

Temperatures are not the minimum nor the maximum (except where specifically stated) but represent standard test conditions. The products may be suitable at higher temperatures but individual test data should be required to establish suitability.

The recommendations or suggestions contained in this chart are made without guarantee or representation as to results. We suggest that you evaluate the recommendations and suggestions in your own laboratory or actual field trial prior to use.

Fiberglass Materials

Recommended Guideline:

Temperature	Design Load Multiplier
75°F (24°C)	100%
100°F (38°C)	90%
125°F (52°C)	78%
150°F (66°C)	68%
175°F (79°C)	60%
200°F (93°C)	52%

Flame Retardant Properties	BFP	BFV
Flame Resistance (FTMS 406-2023) ign/burn, seconds	75/75	75/75
Intermittent Flame Test (HLT-15), rating	100	100
Flammability Test (ASTM D635) Ignition Burning Time	none 0 sec.	none 0 sec.
Surface Burning Characteristics (ASTM E84), Flame spread index	25	25
UL 94 Flame Class	V-0	V-0

Reference page 182 for general fitting specifications.

Fiberglass

BFP22 THRU BFV22SH

- Channel lengths: 10 Ft. (3.05 m) and 20 Ft. (6.09 m)
- Fiberglass strut meets specification of ASTM D-4385 Levels III and IV.

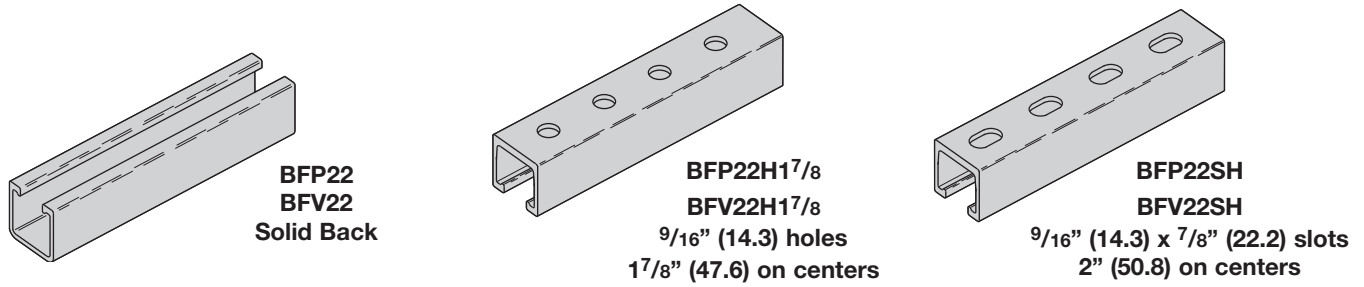

Part No.	Material	Description	Color	Weight	
				Lbs./ft.	kg/m
BFP22*	Polyester Resin	Solid Back	Gray	.63	(.94)
BFV22*	Vinyl Ester Resin	Solid Back	Beige	.63	(.94)
BFP22H17/8*	Polyester Resin	Holes in Back	Gray	.60	(.89)
BFV22H17/8*	Vinyl Ester Resin	Holes in Back	Beige	.60	(.89)
BFP22SH*	Polyester Resin	Slots in Back	Gray	.61	(.91)
BFV22SH*	Vinyl Ester Resin	Slots in Back	Beige	.61	(.91)

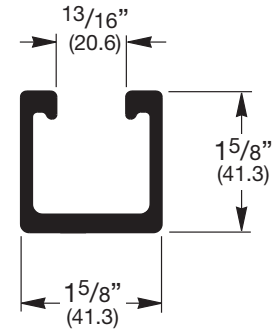

* Insert -10 for 10'-0" (3.05 m) length or -20 for 20'-0" (6.09 m) length

BFP22A BFV22A

- Channel Lengths: 10 Ft. (3.05 m) and 20 Ft. (6.09 m)
- Fiberglass strut meets specification of ASTM D-4385 Levels III and IV.

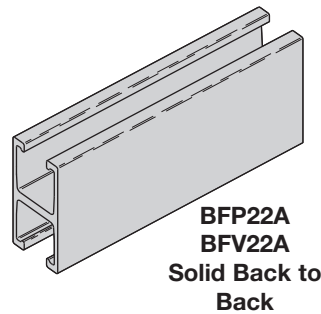

Part No.	Material	Description	Color	Weight	
				Lbs./ft.	kg/m
BFP22A*	Polyester Resin	Back To Back	Gray	1.15	(1.71)
BFV22A*	Vinyl Ester Resin	Back To Back	Beige	1.15	(1.71)

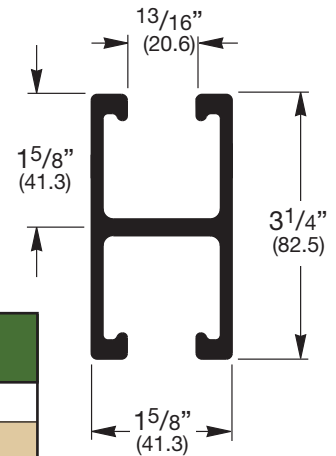

* Insert -10 for 10'-0" (3.05 m) length or -20 for 20'-0" (6.09 m) length

WARNING: Appropriate protective clothing and respiratory protection device should be worn when field cutting or grinding fiberglass.

Published design loads on page 185 are based on usage at 70°F (21°C) and must be reduced for continuous exposure to higher temperatures. Refer to the chart below for high temperature applications.

Field Cutting Sealant Kits

RSK010 Pint Sealing Kit (473 cm³) includes sealant and brush applicator

- Seals exposed fibers after field cutting. •
- UV resistant •

Temperature	Design Load Multiplier
75°F (24°C)	100%
100°F (38°C)	90%
125°F (52°C)	78%
150°F (66°C)	68%
175°F (79°C)	60%
200°F (93°C)	52%

Reference page 182 for general fitting specifications.

BEAM LOADING DATA FOR GLASS REINFORCED POLYESTER RESIN

Beam Span		Part No.	Maximum Allowable Beam Load		Deflection @ Maximum Allowable Beam Load		Allowable Load @ Deflection =				
			Lbs.	kN	in.	mm	1/240 Span		1/360 Span		
in.	mm							Lbs.	kN	Lbs.	kN
12"	(305)	BFP22	1781	(7.92)	0.064	(1.62)	1392	(6.19)	928	(4.13)	
		BFP22A	2259	(10.05)	0.037	(.94)	2259	(10.05)	2051	(9.12)	
24"	(609)	BFP22	890	(3.96)	0.256	(6.50)	347	(1.54)	231	(1.03)	
		BFP22A	1127	(5.01)	0.147	(3.73)	767	(3.41)	511	(2.27)	
36"	(914)	BFP22	592	(2.63)	0.576	(14.63)	153	(0.68)	101	(0.45)	
		BFP22A	750	(3.33)	0.330	(8.38)	338	(1.50)	224	(0.99)	
48"	(1219)	BFP22	443	(1.97)	1.024	(26.01)	85	(0.38)	55	(0.24)	
		BFP22A	560	(2.49)	0.587	(14.91)	188	(0.83)	123	(0.55)	
60"	(1524)	BFP22	353	(1.57)	1.600	(40.64)	53	(0.23)	34	(0.15)	
		BFP22A	446	(1.98)	0.918	(23.32)	117	(0.52)	76	(0.34)	
72"	(1829)	BFP22	293	(1.30)	2.303	(58.49)	35	(0.15)	22	(0.10)	
		BFP22A	370	(1.64)	1.322	(33.58)	78	(0.34)	50	(0.22)	
96"	(2438)	BFP22	218	(0.97)	4.095	(104.01)	17	(0.07)	9	(0.04)	
		BFP22A	273	(1.21)	2.350	(59.69)	39	(0.17)	23	(0.10)	
120"	(3048)	BFP22	172	(0.76)	6.398	(162.51)	8	(0.03)	3	(0.01)	
		BFP22A	214	(0.95)	3.671	(93.24)	19	(0.08)	9	(0.04)	

BEAM LOADING DATA FOR GLASS REINFORCED VINYL ESTER RESIN

Beam Span		Part No.	Maximum Allowable Beam Load		Deflection @ Maximum Allowable Beam Load		Allowable Load @ Deflection =				
			Lbs.	kN	in.	mm	1/240 Span		1/360 Span		
in.	mm							Lbs.	kN	Lbs.	kN
12"	(305)	BFV22	2220	(9.87)	0.071	(1.80)	1568	(6.97)	1045	(4.65)	
		BFV22A	6442	(28.65)	0.039	(0.99)	6442	(29.65)	5549	(24.68)	
24"	(609)	BFV22	1109	(4.93)	0.283	(7.19)	391	(1.74)	260	(1.15)	
		BFV22A	3219	(14.32)	0.155	(3.94)	2079	(9.25)	1385	(6.16)	
36"	(914)	BFV22	738	(3.28)	0.637	(16.18)	172	(0.76)	114	(0.51)	
		BFV22A	2144	(9.53)	0.348	(8.84)	922	(4.10)	613	(2.72)	
48"	(1219)	BFV22	553	(2.46)	1.133	(28.78)	96	(0.43)	63	(0.28)	
		BFV22A	1606	(7.14)	0.619	(15.72)	516	(2.29)	342	(1.52)	
60"	(1524)	BFV22	441	(1.96)	1.770	(44.96)	60	(0.26)	39	(0.17)	
		BFV22A	1283	(5.70)	0.967	(24.56)	327	(1.45)	216	(0.96)	
72"	(1829)	BFV22	366	(1.63)	2.549	(64.74)	40	(0.18)	25	(0.11)	
		BFV22A	1067	(4.74)	1.393	(35.38)	224	(0.99)	147	(0.65)	
96"	(2438)	BFV22	273	(1.21)	4.531	(115.09)	19	(0.08)	11	(0.05)	
		BFV22A	796	(3.54)	2.477	(62.91)	121	(0.54)	78	(0.34)	
120"	(3048)	BFV22	216	(0.96)	7.079	(179.80)	9	(0.04)	7	(0.02)	
		BFV22A	633	(2.81)	3.870	(98.30)	72	(0.32)	44	(0.19)	

Loading Information

Beam Loads:

The above charts list the total allowable uniform load for various simple spans based on a minimum safety factor of 2. If the load is concentrated at center span, multiply the load from the above charts by 0.5 and the corresponding deflection by 0.8.

All beams should be supported in a manner to prevent rotation at supports. Long, deep beams should be tied between supports to prevent twist. For channels with holes or slots use 90% of recommended load shown in channel loading chart.

Reference page 182 for general fitting specifications.

Fiberglass

BFP42 THRU BFV42SH

- Channel lengths: 10 Ft. (3.05 m) and 20 Ft. (6.09 m)
- Fiberglass strut meets specification of ASTM D-4385 Levels III and IV.

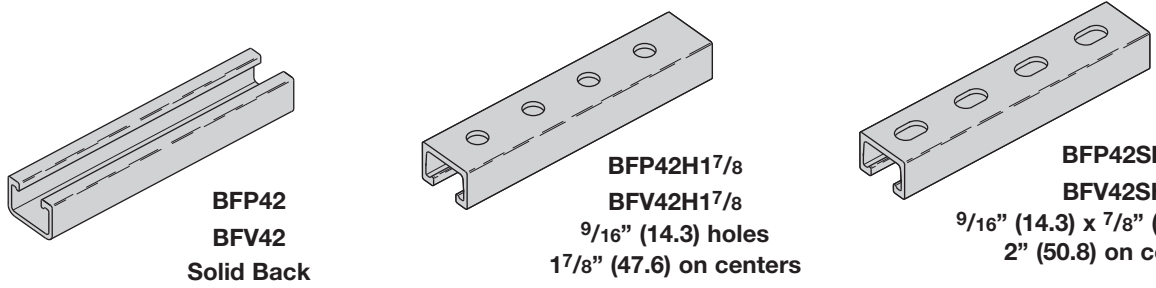

Part No.	Material	Description	Color	Weight	
				Lbs./ft.	kg/m
BFP42*	Polyester Resin	Solid Back	Gray	.48	(.71)
BFV42*	Vinyl Ester Resin	Solid Back	Beige	.48	(.71)
BFP42H1 7/8*	Polyester Resin	Holes in Back	Gray	.46	(.68)
BFV42H1 7/8*	Vinyl Ester Resin	Holes in Back	Beige	.46	(.68)
BFP42SH*	Polyester Resin	Slots in Back	Gray	.47	(.70)
BFV42SH*	Vinyl Ester Resin	Slots in Back	Beige	.47	(.70)

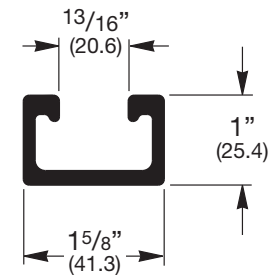

* Insert -10 for 10'-0" (3.05 m) length or -20 for 20'-0" (6.09 m) length

BFP42A BFV42A

- Channel lengths: 10 Ft. (3.05 m) and 20 Ft. (6.09 m)
- Fiberglass strut meets specification of ASTM D-4385 Levels III and IV.

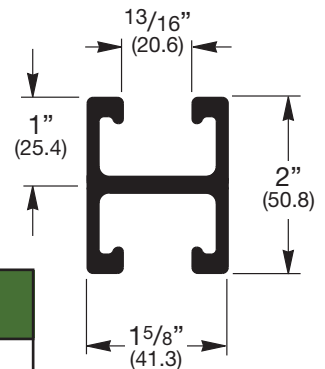
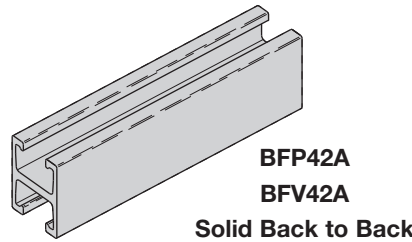

Part No.	Material	Description	Color	Weight	
				Lbs./ft.	kg/m
BFP42A*	Polyester Resin	Back To Back	Gray	.85	(1.26)
BFV42A*	Vinyl Ester Resin	Back To Back	Beige	.85	(1.26)

* Insert -10 for 10'-0" (3.05 m) length or -20 for 20'-0" (6.09 m) length

WARNING: Appropriate protective clothing and respiratory protection device should be worn when field cutting or grinding fiberglass.

Published design loads on page 187 are based on usage at 70°F (21°C) and must be reduced for continuous exposure to higher temperatures. Refer to the chart below for high temperature applications.

Field Cutting Sealant Kits

RSK010 Pint Sealing Kit (473 cm³) includes sealant and brush applicator

- Seals exposed fibers after field cutting. •
- UV resistant •

Temperature	Design Load Multiplier
75°F (24°C)	100%
100°F (38°C)	90%
125°F (52°C)	78%
150°F (66°C)	68%
175°F (79°C)	60%
200°F (93°C)	52%

Reference page 182 for general fitting specifications.

BEAM LOADING DATA FOR GLASS REINFORCED POLYESTER RESIN

Beam Span		Part No.	Maximum Allowable Beam Load		Deflection @ Maximum Allowable Beam Load		Allowable Load @ Deflection =			
							1/240 Span		1/360 Span	
in.	mm		Lbs.	kN	in.	mm	Lbs.	kN	Lbs.	kN
12"	(305)	BFP42	841	(3.74)	0.104	(2.64)	403	(1.79)	269	(1.19)
		BFP42A	2325	(10.34)	0.060	(1.52)	1948	(8.66)	1299	(5.78)
24"	(609)	BFP42	420	(1.87)	0.417	(10.59)	100	(0.44)	66	(0.29)
		BFP42A	1161	(5.16)	0.239	(6.07)	486	(2.16)	323	(1.43)
36"	(914)	BFP42	279	(1.24)	0.938	(23.82)	43	(0.19)	29	(0.13)
		BFP42A	773	(3.44)	0.537	(13.64)	214	(0.95)	142	(0.63)
48"	(1219)	BFP42	208	(0.92)	1.667	(42.34)	23	(0.10)	15	(0.06)
		BFP42A	578	(2.57)	0.955	(24.26)	119	(0.53)	78	(0.34)
60"	(1524)	BFP42	166	(0.74)	2.604	(66.14)	14	(0.06)	8	(0.03)
		BFP42A	461	(2.05)	1.491	(37.87)	74	(0.33)	48	(0.21)
72"	(1829)	BFP42	137	(0.61)	3.750	(95.25)	8	(0.03)	5	(0.02)
		BFP42A	383	(1.70)	2.148	(54.56)	49	(0.22)	31	(0.14)
96"	(2438)	BFP42	101	(0.45)	6.667	(169.34)	3	(0.01)	–	–
		BFP42A	284	(1.26)	3.818	(96.98)	24	(0.10)	14	(0.04)
120"	(3048)	BFP42	79	(0.35)	10.417	(264.59)	–	–	–	–
		BFP42A	224	(0.99)	5.966	(151.53)	11	(0.05)	5	(0.02)

BEAM LOADING DATA FOR GLASS REINFORCED VINYL ESTER RESIN

Beam Span		Part No.	Maximum Allowable Beam Load		Deflection @ Maximum Allowable Beam Load		Allowable Load @ Deflection =			
							1/240 Span		1/360 Span	
in.	mm		Lbs.	kN	in.	mm	Lbs.	kN	Lbs.	kN
12"	(305)	BFV42	988	(4.39)	0.112	(2.84)	440	(1.96)	293	(1.30)
		BFV42A	2865	(12.74)	0.063	(1.60)	2278	(10.13)	1518	(6.75)
24"	(609)	BFV42	493	(2.19)	0.448	(11.38)	109	(0.48)	73	(0.32)
		BFV42A	1431	(6.36)	0.252	(6.40)	568	(2.52)	378	(1.68)
36"	(914)	BFV42	328	(1.46)	1.009	(25.63)	48	(0.21)	31	(0.14)
		BFV42A	953	(4.24)	0.566	(14.37)	251	(1.11)	166	(0.74)
48"	(1219)	BFV42	245	(1.09)	1.793	(45.54)	26	(0.11)	16	(0.07)
		BFV42A	713	(3.17)	1.006	(25.55)	139	(0.62)	92	(0.41)
60"	(1524)	BFV42	195	(0.87)	2.802	(71.17)	15	(0.06)	9	(0.04)
		BFV42A	569	(2.53)	1.572	(39.93)	87	(0.38)	57	(0.25)
72"	(1829)	BFV42	162	(0.72)	4.035	(102.49)	9	(0.04)	5	(0.02)
		BFV42A	473	(2.10)	2.264	(57.50)	58	(0.26)	37	(0.16)
96"	(2438)	BFV42	120	(0.53)	7.173	(182.19)	3	(0.01)	1	(0.004)
		BFV42A	351	(1.56)	4.025	(102.23)	29	(0.13)	17	(0.07)
120"	(3048)	BFV42	94	(0.42)	11.207	(284.66)	–	–	–	–
		BFV42A	278	(1.23)	6.288	(159.71)	14	(0.06)	7	(0.03)

Loading Information

Beam Loads:

The above charts list the total allowable uniform load for various simple spans based on a minimum safety factor of 2. If the load is concentrated at center span, multiply the load from the above charts by 0.5 and the corresponding deflection by 0.8.

All beams should be supported in a manner to prevent rotation at supports. Long, deep beams should be tied between supports to prevent twist. For channels with holes or slots use 90% of recommended load shown in channel loading chart.

Reference page 182 for general fitting specifications.

Fiberglass

BF*22I CONCRETE INSERTS

- Design Load 300 Lbs (1.47 kN)
- Safety Factor of 3
- Standard lengths: 6" (152), 12" (305), 24" (609), 36" (914), 48" (1219), 60" (1524), 72" (1829), 84" (2133), 96" (2438), 108" (2743) and 120" (3048)
- Available Material:
 - *Insert P for BFP - Polyester Resin channel and tee
 - *Insert V for BFV - Vinyl Ester Resin channel with Polyester Resin tee
- Shipped with removable styrofoam insert

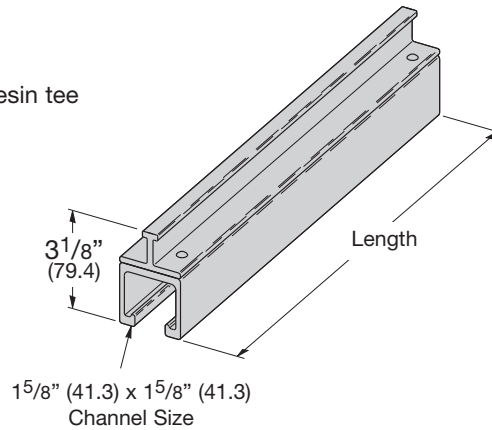

Field Cutting Sealant Kits

RSK010 ... Pint Sealing Kit (473 cm³)
includes sealant and brush applicator

- Seals exposed fibers after field cutting •
- UV resistant •

BFV501 SERIES U-BOLTS WITH HEX NUTS

- Design Load Safety Factor of 3
- Load A: Straight down loading
- Load B: Side loading
- Inner surface of U-Bolt is flat to provide additional contact surface area
- Material: Glass Reinforced Polyurethane

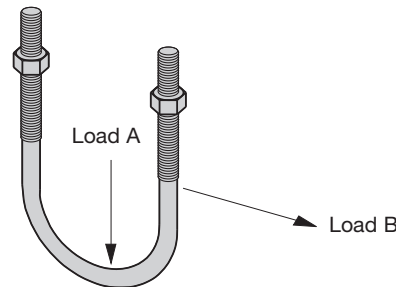

Part No.	Nominal Pipe Size		Thread Size	Design Load A		Design Load B		Maximum Torque		Wt./C	
	in.	mm		Lbs.	kN	Lbs.	kN	in.-Lbs.	N•m	Lbs.	kg
BFV501-1/2	1/2	(15)	3/8"-16	300	(1.33)	150	(.67)	30	(3.4)	3.5	(1.59)
BFV501-3/4	3/4	(20)	3/8"-16	300	(1.33)	150	(.67)	30	(3.4)	3.9	(1.77)
BFV501-1	1	(25)	3/8"-16	300	(1.33)	150	(.67)	30	(3.4)	4.4	(1.99)
BFV501-1 1/4	1 1/4	(32)	3/8"-16	300	(1.33)	150	(.67)	30	(3.4)	4.8	(2.18)
BFV501-1 1/2	1 1/2	(40)	3/8"-16	300	(1.33)	150	(.67)	30	(3.4)	5.2	(2.36)
BFV501-2	2	(50)	1/2"-13	600	(2.67)	200	(.89)	60	(6.8)	7.7	(3.49)
BFV501-2 1/2	2 1/2	(65)	1/2"-13	600	(2.67)	200	(.89)	60	(6.8)	10.2	(4.63)
BFV501-3	3	(80)	1/2"-13	600	(2.67)	200	(.89)	60	(6.8)	12.6	(5.71)
BFV501-3 1/2	3 1/2	(90)	1/2"-13	600	(2.67)	200	(.89)	60	(6.8)	15.1	(6.85)
BFV501-4	4	(100)	1/2"-13	600	(2.67)	200	(.89)	60	(6.8)	17.6	(7.98)

Reference page 182 for general fitting specifications.

CHANNEL NUTS

- Design Load Safety Factor of 3
- Overall Nut Height $\frac{5}{8}$ " (15.9)
- Maximum torque and slip resistance loads shown are when using stainless steel bolts. When using fiberglass hardware use Max. Torque for fiberglass bolts, and multiply slip resistance loads by .14 for $\frac{3}{8}$ " and .60 for $\frac{1}{2}$ " thread size.
- Material: Glass Reinforced Polyurethane
- Spring Material: Zinc Plated Steel

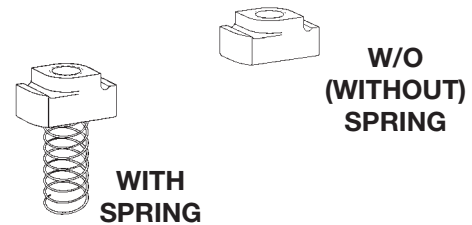

Part No. With Spring	Part No. W/O Spring	Thread Size	Pull-Out		Slip Resistance		Max. Torque		Wt./C	
			Lbs	kN	Lbs.	N	in.-Lbs.	N•m	Lbs.	kg
BFV-224	BFV-224WO	$\frac{1}{4}$ "-20	300	(1.33)	150	(.67)	200	(22.6)	2.4	(1.09)
BFV-223	BFV-223WO	$\frac{5}{16}$ "-18	300	(1.33)	150	(.67)	200	(22.6)	2.5	(1.13)
BFV-228	BFV-228WO	$\frac{3}{8}$ "-16	300	(1.33)	150	(.67)	200	(22.6)	2.3	(1.04)
BFV-225	BFV-225WO	$\frac{1}{2}$ "-13	300	(1.33)	150	(.67)	200	(22.6)	2.1	(0.95)

BFVHHCS HEX HEAD CAP SCREWS

- Design Load Safety Factor of 3
- Material: Glass Reinforced Polyurethane

Part No.	Thread Size	Design Load (in tension)		Max. Torque		Wt./C	
		Lbs.	kN	in.-Lbs.	N•m	Lbs.	kg
BFVHHCS $\frac{5}{16}$ x 1	$\frac{5}{16}$ "-18	190	(.84)	30	(3.4)	.4	(.18)
BFVHHCS $\frac{5}{16}$ x $1\frac{1}{4}$	$\frac{5}{16}$ "-18	190	(.84)	30	(3.4)	.5	(.23)
BFVHHCS $\frac{5}{16}$ x $1\frac{1}{2}$	$\frac{5}{16}$ "-18	190	(.84)	30	(3.4)	.6	(.27)
BFVHHCS $\frac{5}{16}$ x 2	$\frac{5}{16}$ "-18	190	(.84)	30	(3.4)	.8	(.36)
BFVHHCS $\frac{3}{8}$ x 1	$\frac{3}{8}$ "-16	300	(1.33)	45	(5.1)	.9	(.41)
BFVHHCS $\frac{3}{8}$ x $1\frac{1}{4}$	$\frac{3}{8}$ "-16	300	(1.33)	45	(5.1)	1.1	(.50)
BFVHHCS $\frac{3}{8}$ x $1\frac{1}{2}$	$\frac{3}{8}$ "-16	300	(1.33)	45	(5.1)	1.3	(.59)
BFVHHCS $\frac{3}{8}$ x 2	$\frac{3}{8}$ "-16	300	(1.33)	45	(5.1)	1.3	(.59)
BFVHHCS $\frac{3}{8}$ x $2\frac{1}{2}$	$\frac{3}{8}$ "-16	300	(1.33)	45	(5.1)	1.5	(.68)
BFVHHCS $\frac{1}{2}$ x 1	$\frac{1}{2}$ "-13	490	(2.18)	110	(12.4)	1.4	(.63)
BFVHHCS $\frac{1}{2}$ x $1\frac{1}{4}$	$\frac{1}{2}$ "-13	490	(2.18)	110	(12.4)	1.8	(.81)
BFVHHCS $\frac{1}{2}$ x $1\frac{1}{2}$	$\frac{1}{2}$ "-13	490	(2.18)	110	(12.4)	2.2	(1.00)
BFVHHCS $\frac{1}{2}$ x 2	$\frac{1}{2}$ "-13	490	(2.18)	110	(12.4)	3.0	(1.36)
BFVHHCS $\frac{1}{2}$ x $2\frac{1}{2}$	$\frac{1}{2}$ "-13	490	(2.18)	110	(12.4)	3.7	(1.68)
BFVHHCS $\frac{1}{2}$ x 3	$\frac{1}{2}$ "-13	490	(2.18)	110	(12.4)	4.5	(2.04)

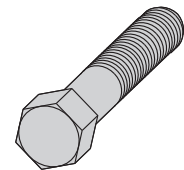

BFVHN HEX NUTS

- $\frac{3}{4}$ " & 1" sizes are available. Contact inside sales for details
- Material: Glass Reinforced Polyurethane

Part No.	Thread Size	Nut Thickness		Wt./C	
		in.	mm	Lbs.	kg
BFVHN $\frac{5}{16}$	$\frac{5}{16}$ "-18	$\frac{17}{64}$	(6.7)	.2	(.09)
BFVHN $\frac{3}{8}$	$\frac{3}{8}$ "-16	$\frac{21}{64}$	(8.3)	.3	(.13)
BFVHN $\frac{1}{2}$	$\frac{1}{2}$ "-13	$\frac{7}{16}$	(11.1)	.7	(.32)
BFVHN $\frac{5}{8}$	$\frac{5}{8}$ "-11	$\frac{35}{64}$	(13.9)	1.4	(.63)

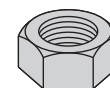

Reference page 182 for general fitting specifications.

Fiberglass

BFVATR ALL THREADED ROD

- Design Load Safety Factor of 3
- Use ATR nuts in place of hex nuts with 3/8"-16 and 1/2"-13 threaded rod in order to obtain minimum required thread engagement of 1 7/32" (13.5) to obtain design load shown below.
- Material: Glass Reinforced Vinyl Ester

Part No.	Thread Size	Design Load (in tension)		Max. Torque		Wt./Ft.	
		Lbs.	kN	in.-Lbs.	N•m	Lbs.	kg
BFVATR 3/8 x 48"	3/8"-16	425	(1.89)	45	(5.1)	.08	(.04)
BFVATR 1/2 x 48"	1/2"-13	750	(3.33)	110	(12.4)	.13	(.06)
BFVATR 5/8 x 48"	5/8"-11	950	(4.22)	230	(26.0)	.21	(.09)

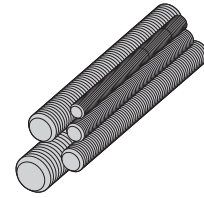

BFVATRHN THREADED ROD NUTS

- ATR Nut is required with 3/8"-16 and 1/2"-13 ATR to provide additional thread engagement which is critical to ATR load carrying capacity.
- Material: Glass Reinforced Polyurethane

Part No.	Thread Size	H		Wt./C	
		in.	mm	Lbs.	kg
BFVATRHN 3/8	3/8"-16	3/4	(19)	.8	(.36)
BFVATRHN 1/2	1/2"-13	7/8	(22)	1.7	(.77)

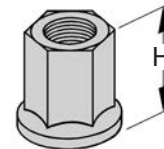

BFVFW FLAT WASHERS

- Material: PVC

Part No.	Hole Size in.	Wt./C	
		Lbs.	kg
BFVFW 3/8	3/8	.5	(.22)
BFVFW 1/2	1/2	.5	(.22)
BFVFW 5/8	5/8	.5	(.22)
BFVFW 3/4	3/4	.5	(.22)
BFVFW 1	1	.5	(.22)

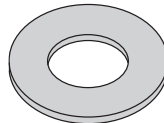

BFV655 SERIES ROD COUPLINGS

- Material: Glass Reinforced Polyurethane

Part No.	Thread Size	Wt./C	
		Lbs.	kg
BFV655-3/8	3/8"-16	7.4	(3.35)
BFV655-1/2	1/2"-13	11.3	(5.12)
BFV655-5/8	5/8"-11	16.7	(7.57)



BFVSL SERIES STOP-LOCK KITS

- Material: Glass Reinforced Polyurethane

Part No.	Thread Size	Wt./C	
		Lbs.	kg
BFVSL-3/8	3/8"-16	7.4	(3.35)
BFVSL-1/2	1/2"-13	11.3	(5.12)

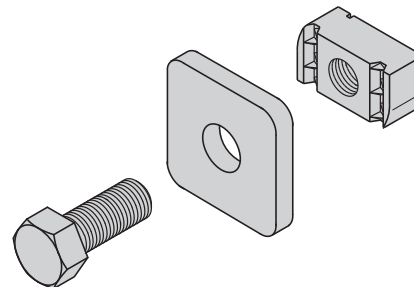

Reference page 182 for general fitting specifications.

BFV100 thru BFV300 ADJUSTABLE PIPE CLAMPS

- Completely Non-Metallic
 - Adjustable to U.S. & Metric Pipe Diameters
 - Fits OD Sizes 3/4" (19.0) to 3 1/2" (88.9)
 - Easy To Install
 - No Special Tools Required
 - Design Load Safety Factor of 3
 - Material: Glass Reinforced Polyurethane
 - Not recommended for vertical installation without additional Stop-Lock Kit. Kit includes one square washer, channel nut and hex head cap screw.
- Order (Stop-Lock Kit on page 190) BFVSL-3/8 for 3/8"-16 hardware or BFVSL-1/2 for 1/2"-13 hardware. Mount kit below clamp when used in vertical strut to prevent clamp slipping.

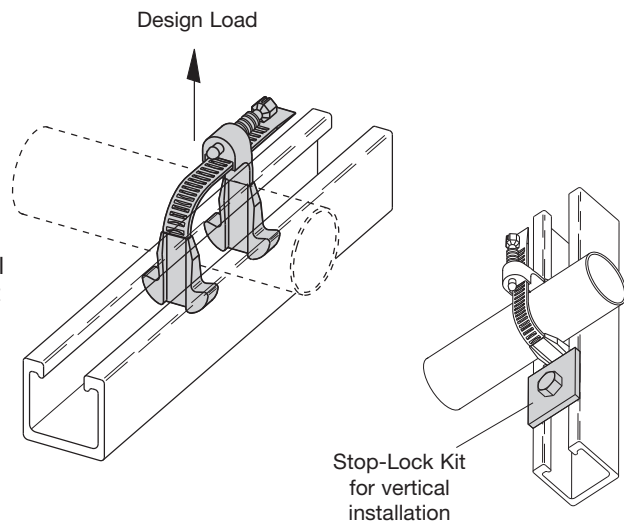

Part No.	Nominal Pipe Sizes		Pipe O.D. Range		Design Load		Max. Torque	
	in.	mm	in.	mm	Lbs.	kN	in.-Lbs.	N•m
BFV100	1/2 - 1 1/2	(15 - 40)	.75 - 1.90	(21.3 - 48.3)	135	(.60)	10	(1.13)
BFV200	1 1/2 - 2	(40 - 51)	1.90 - 2.37	(48.3 - 60.3)	135	(.60)	36	(4.07)
BFV300	2 1/2 - 3	(63 - 76)	2.87 - 3.50	(73.0 - 88.9)	145	(.64)	36	(4.07)

BFV2000 SERIES NON-METALLIC PIPE CLAMPS

- For rigid and PVC conduit.
 - Standard hardware includes slotted round head machine screw and square nut in 316 stainless steel
 - Design Load Safety Factor of 3
 - Material: Glass Reinforced PPO
 - Not recommended for vertical installation without additional Stop-Lock Kit. Kit includes one square washer, channel nut and hex head cap screw.
- Order (Stop-Lock Kit on page 190) BFVSL-3/8 for 3/8"-16 hardware or BFVSL-1/2 for 1/2"-13 hardware. Mount kit below clamp when used in vertical strut to prevent clamp slipping.
- If non-metallic hardware is required, add N to the part number.
- Example: BFV2008N**

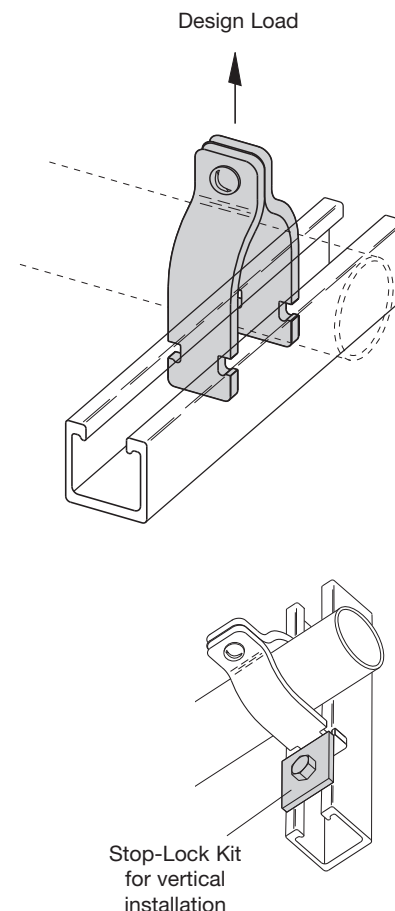

Part No.	Nominal Pipe Size		Design Load		Maximum Torque	
	in.	mm	Lbs.	kN	in.-Lbs.	N•m
BFV2008	1/2	(15)	300	(1.33)	10	(1.13)
BFV2009	3/4	(20)	300	(1.33)	10	(1.13)
BFV2010	1	(25)	300	(1.33)	10	(1.13)
BFV2011	1 1/4	(32)	300	(1.33)	10	(1.13)
BFV2012	1 1/2	(40)	300	(1.33)	10	(1.13)
BFV2013	2	(50)	300	(1.33)	10	(1.13)
BFV2014	2 1/2	(65)	300	(1.33)	10	(1.13)
BFV2015	3	(80)	300	(1.33)	10	(1.13)
BFV2016	3 1/2	(90)	300	(1.33)	10	(1.13)
BFV2017	4	(100)	300	(1.33)	10	(1.13)

Reference page 182 for general fitting specifications.

Fiberglass

BFP2400 SERIES 2-HOLE PIPE CLAMPS

- Design Load Safety Factor of 3
- Material: Glass Reinforced Polyester

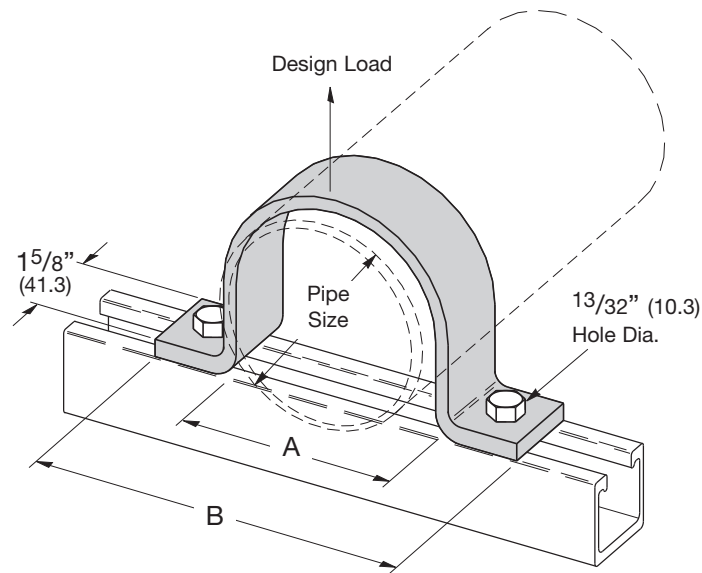

Part No.	Nominal Pipe Size		A		B		Design Load	
	in.	mm	in.	mm	in.	mm	Lbs.	kN
BFP2400-2	2	(50)	2 ³ / ₈	(60)	5 ¹ / ₂	(140)	115	(0.51)
BFP2400-3	3	(80)	3 ¹ / ₂	(89)	6 ³ / ₄	(171)	130	(0.58)
BFP2400-4	4	(100)	4 ¹ / ₂	(114)	7 ³ / ₄	(197)	150	(0.66)
BFP2400-6	6	(150)	6 ⁵ / ₈	(168)	10	(254)	150	(0.66)

BFV751 & BFV751J BEAM CLAMP

- Design Load Safety Factor of 3
- BFV751J (clip included) must be used when installed on tapered flange beams.
- Material: Glass Reinforced Polyurethane
- Setscrew material: Stainless Steel 316 ASTM F593 Group 2, S4

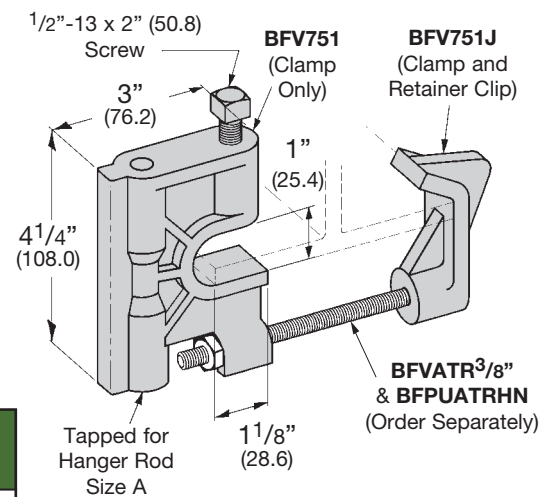

Part No.	For Hanger Rod Size A	Design Load		Torque	
		Lbs.	kN	ft.-Lbs.	N•m
BFV751-3/8	3/8"-16	500	(2.22)	10	(13)
BFV751J-3/8	3/8"-16	500	(2.22)	10	(13)
BFV751-1/2	1/2"-13	500	(2.22)	10	(13)
BFV751J-1/2	1/2"-13	500	(2.22)	10	(13)
BFV751-5/8	5/8"-11	500	(2.22)	10	(13)
BFV751J-5/8	5/8"-11	500	(2.22)	10	(13)

Reference page 182 for general fitting specifications.

BFV755 BEAM CLAMP

- Design Load Safety Factor of 3
- Material: Glass Reinforced Polyurethane
- Setscrew material: Stainless Steel 316
ASTM F593 Group 2, S4

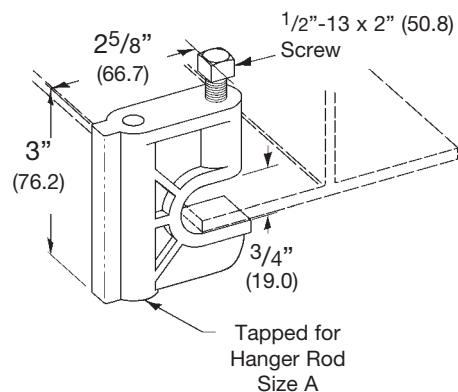

Part No.	For Hanger Rod Size A	Design Load		Torque	
		Lbs.	kN	ft.-Lbs.	N*m
BFV755-3/8	3/8"-16	400	(1.78)	10	(13)
BFV755-1/2	1/2"-13	400	(1.78)	10	(13)

BFV3104 SERIES CLEVIS HANGERS

- Design Load Safety Factor of 3 at 120°F (49°C).
- Insulation may be required at higher temperatures.
- Order hanger rod and nuts separately.
- Material: Glass Reinforced Polyurethane
For BFV3104-1 thru BFV3104-6
- Material: Glass Reinforced Polyester & Vinyl Ester
For BFV3104-8 thru BFV3104-12

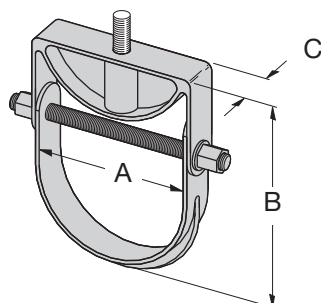

BFV3104-1 thru BFV3104-6

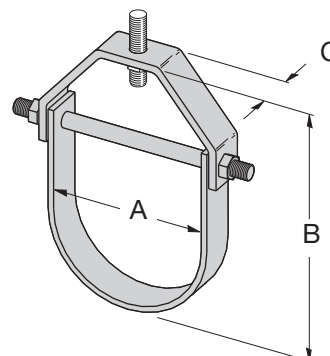

BFV3104-8 thru BFV3104-12

Part No.	Nominal Pipe Size		A		B		C		Hanger Rod Size	Design Load	
	in.	mm	in.	mm	in.	mm	in.	mm		Lbs.	kN
BFV3104-1	1	(50)	1 1/2	(38)	4 1/4	(108)	1 1/4	(32)	1/2"-13	670	(2.98)
BFV3104-1 1/2	1 1/2	(65)	2	(51)	5 1/8	(130)	1 1/4	(32)	1/2"-13	670	(2.98)
BFV3104-2	2	(50)	2 1/2	(63)	6 1/2	(165)	1 1/4	(32)	1/2"-13	730	(3.25)
BFV3104-2 1/2, 3, 4	2 1/2-4	(65-100)	5 1/8	(130)	10	(254)	1 1/2	(38)	1/2"-13	1150	(5.11)
BFV3104-6	6	(150)	6 3/4	(171)	12 5/16	(313)	2	(51)	1/2"-13	1170	(5.20)

Part No.	Nominal Pipe Size		A		B		C		Hanger Rod Size	Design Load	
	in.	mm	in.	mm	in.	mm	in.	mm		Lbs.	kN
BF*3104-8	8	(200)	9 1/4	(235)	16 5/8	(422)	3	(76)	5/8"-11	350	(1.55)
BF*3104-10	10	(250)	11 3/8	(289)	19 7/8	(505)	4	(101)	5/8"-11	450	(2.01)
BF*3104-12	12	(300)	13 1/2	(343)	22 3/8	(568)	5	(127)	5/8"-11	600	(2.69)

*Specify P for polyester or V for Vinyl ester.

Reference page 182 for general fitting specifications.

Fiberglass

BF*409 SERIES

BRACKETS 6" (152) TO 24" (609) LONG

- Design Load Safety Factor of 3 based on uniform loading
- MH1 - From Top of Bracket to center of Mounting Hole
- MH2 - From Bottom of Bracket to center of Mounting Hole

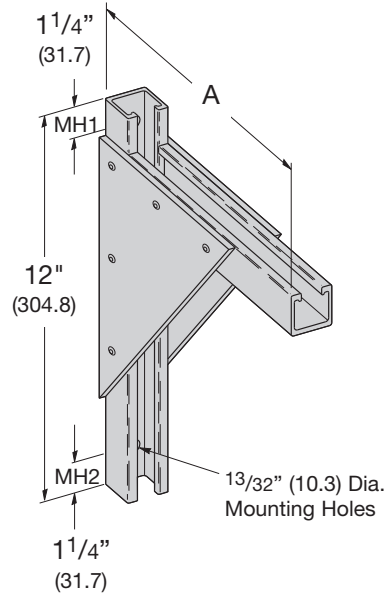

Part No.	A		Design Load	
	in.	mm	Lbs.	kN
BF*409-6	10	(250)	1400	(6.22)
BF*409-9	13	(330)	1000	(4.45)
BF*409-12	16	(406)	800	(3.56)
BF*409-18	22	(559)	675	(3.00)
BF*409-24	28	(711)	450	(2.00)

* Insert P for Glass Reinforced Polyester Resin or V for Glass Reinforced Vinyl Ester Resin

BF*494 SERIES

BRACKETS 24" (609) TO 36" (914) LONG

- Design Load Safety Factor of 3 based on uniform loading
- MH1 - From Top of Bracket to center of Mounting Hole
- MH2 - From Bottom of Bracket to center of Mounting Hole
- Material: Glass Reinforced Vinyl Ester or Polyester

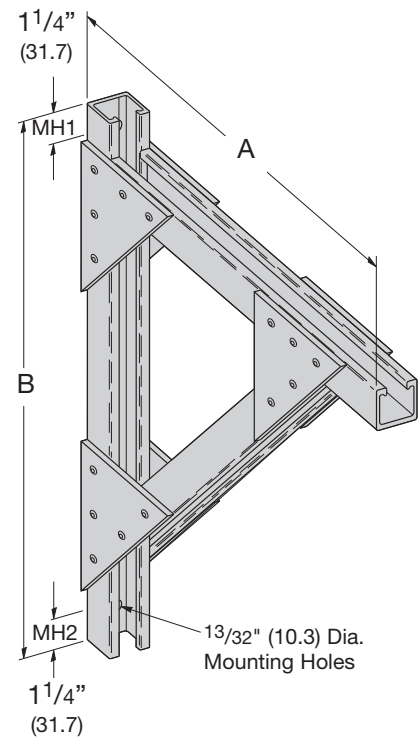

Part No.	A		B		Design Load	
	in.	mm	in.	mm	Lbs.	kN
BF*494-24	28	(711)	23	(584)	750	(3.33)
BF*494-30	34	(863)	26	(660)	750	(3.33)
BF*494-36	40	(1016)	29	(736)	750	(3.33)

* Insert P for Glass Reinforced Polyester Resin or V for Glass Reinforced Vinyl Ester Resin

Reference page 182 for general fitting specifications.

BFV201 SQUARE WASHER FOR 3/8" BOLT

- Material: Injection Molded Glass Reinforced Polyurethane

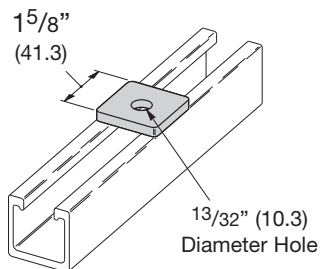

BFV202 SQUARE WASHER FOR 1/2" BOLT

- Material: Injection Molded Glass Reinforced Polyurethane

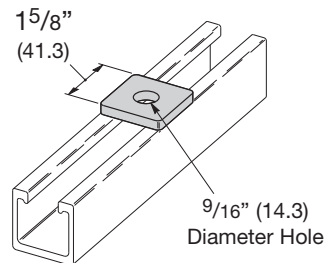

BFV340 TWO HOLE FLAT PLATE

- Material: Injection Molded Glass Reinforced Polyurethane

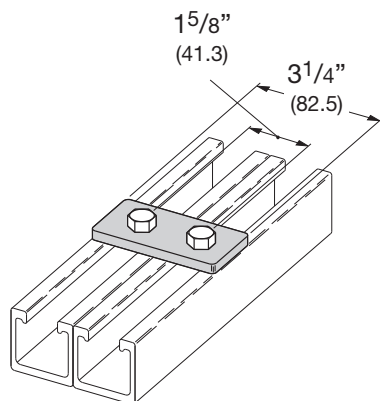

BFV129 TWO HOLE SPLICE PLATE

- Material: Injection Molded Glass Reinforced Polyurethane

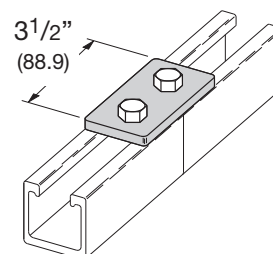

BFV141 THREE HOLE FLAT PLATE

- Material: Injection Molded Glass Reinforced Polyurethane

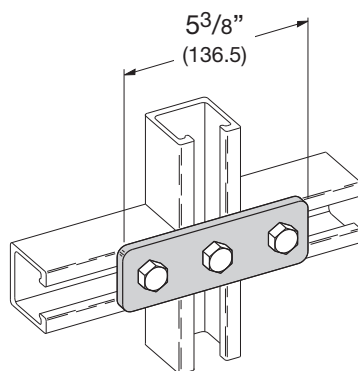

BFV557 THREE HOLE FLAT PLATE

- Material: Injection Molded Glass Reinforced Polyurethane

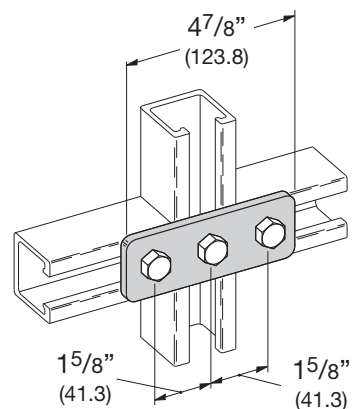

Reference page 182 for general fitting specifications.

Fiberglass

BFV341 FOUR HOLE SPLICE PLATE

- Material: Injection Molded Glass Reinforced Polyurethane

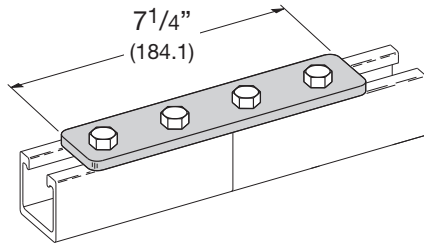

BFV342 FIVE HOLE FLAT PLATE

- Material: Injection Molded Glass Reinforced Polyurethane

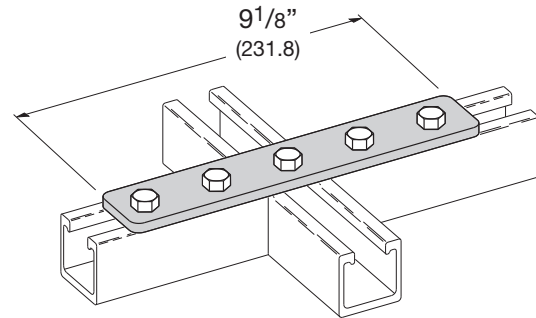

BFV140 THREE HOLE FLAT CORNER PLATE

- Material: Injection Molded Glass Reinforced Polyurethane

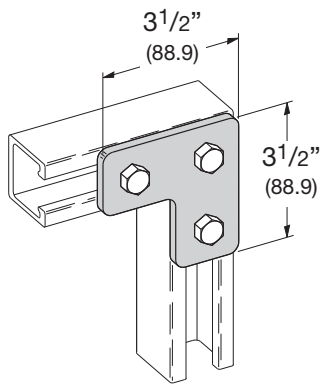

BFV143 FOUR HOLE FLAT CORNER PLATE

- Material: Injection Molded Glass Reinforced Polyurethane

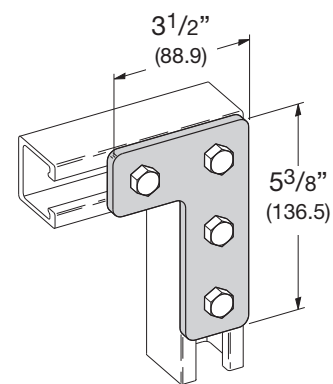

BFV132 FIVE HOLE FLAT CROSS PLATE

- Material: Injection Molded Glass Reinforced Polyurethane

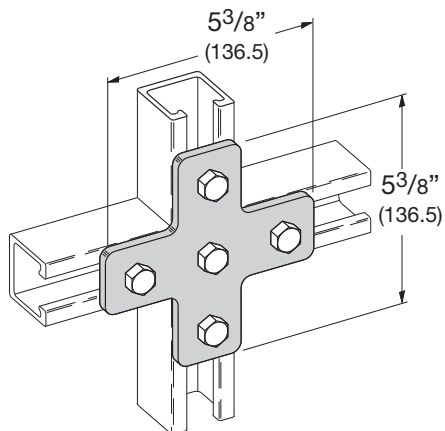

BFV133 FOUR HOLE FLAT TEE PLATE

- Material: Injection Molded Glass Reinforced Polyurethane

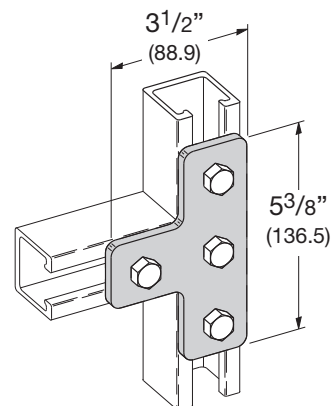

Reference page 182 for general fitting specifications.

BFV135 THREE HOLE FLAT GUSSET CORNER PLATE

- Material: Injection Molded Glass Reinforced Polyurethane

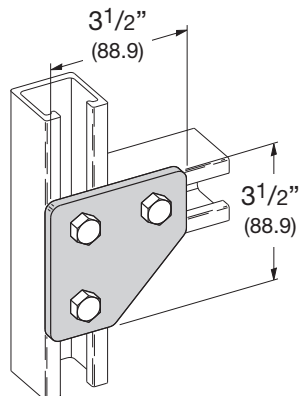

BFV142 FOUR HOLE FLAT GUSSET CORNER PLATE

- Material: Injection Molded Glass Reinforced Polyurethane

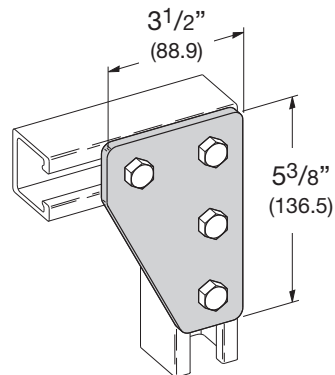

BFV337 THREE HOLE FLAT GUSSET TEE PLATE

- Material: Injection Molded Glass Reinforced Polyurethane

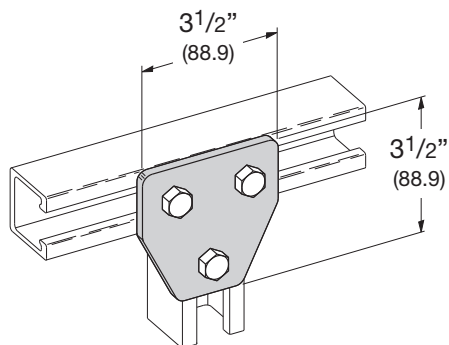

BFV136 FOUR HOLE FLAT GUSSET TEE PLATE

- Material: Injection Molded Glass Reinforced Polyurethane

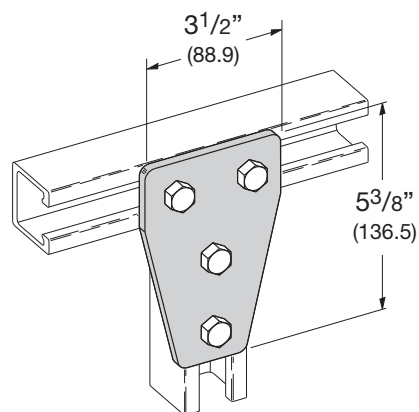

BFV532 FIVE HOLE FLAT GUSSET TEE PLATE

- Material: Injection Molded Glass Reinforced Polyurethane

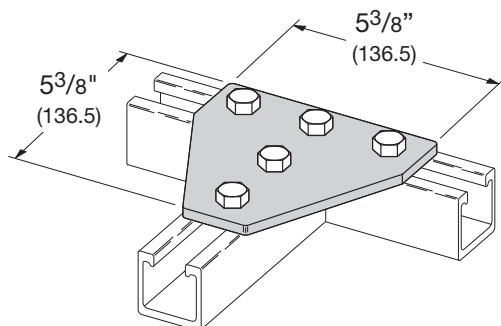

BFV334 SEVEN HOLE FLAT GUSSET CROSS PLATE

- Material: Injection Molded Glass Reinforced Polyurethane

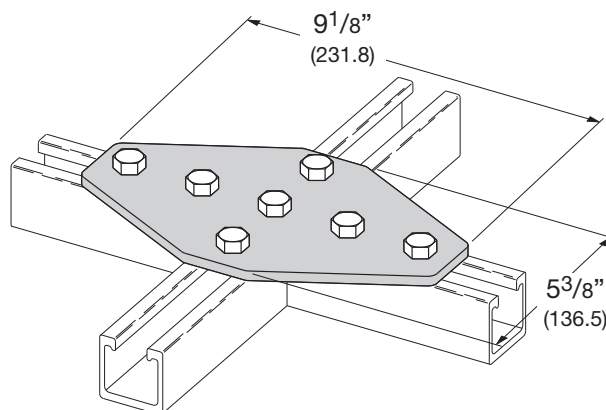

Reference page 182 for general fitting specifications.

BFV101 TWO HOLE 90° CORNER ANGLE

- Material: Injection Molded Glass Reinforced Polyurethane

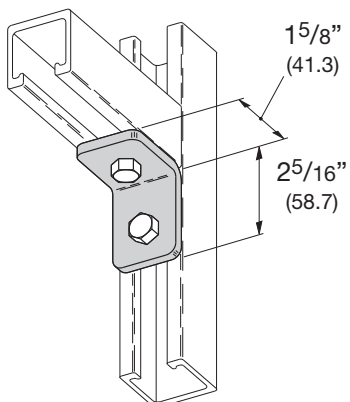

BFV103 THREE HOLE 90° CORNER ANGLE

- Material: Injection Molded Glass Reinforced Polyurethane

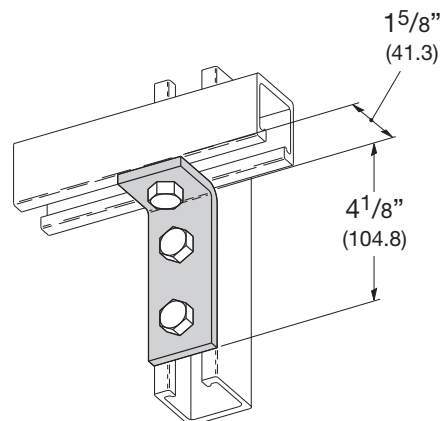

BFV104 FOUR HOLE 90° CORNER ANGLE

- Material: Injection Molded Glass Reinforced Polyurethane

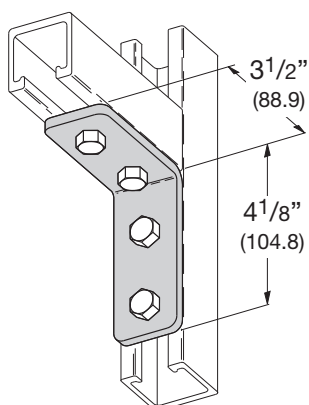

BFV118 FOUR HOLE 90° GUSSETED SHELF ANGLE

- Material: Injection Molded Glass Reinforced Polyurethane

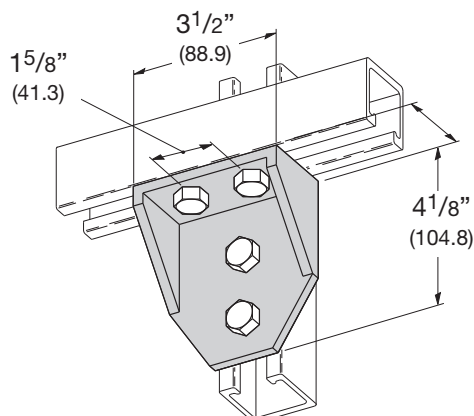

BFV558 FOUR HOLE 90° CORNER ANGLE

- Material: Injection Molded Glass Reinforced Polyurethane

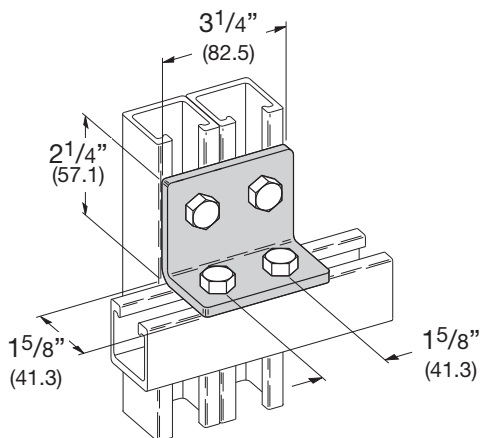

BFV371-2G THREE HOLE 90° GUSSETED CORNER ANGLE

- Material: Injection Molded Glass Reinforced Polyurethane

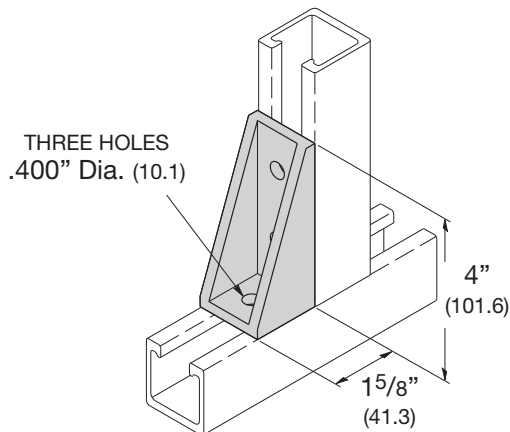

Reference page 182 for general fitting specifications.

BFV280SQ POST BASE FOR BF*22

- Material: Glass Reinforced Polyurethane

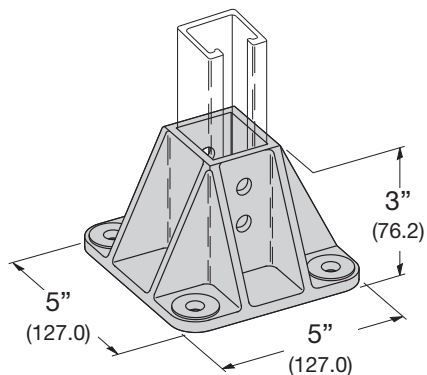

BFV281SQ POST BASE FOR BF*22A

- Material: Glass Reinforced Polyurethane

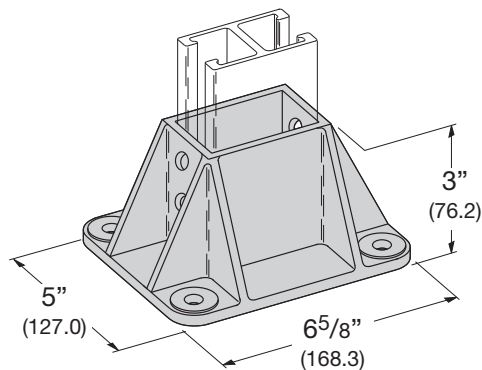

BFV650 CHANNEL SPACER

- Spacer I.D. accommodates 3/8" rod or bolts.
- Material: Polyurethane

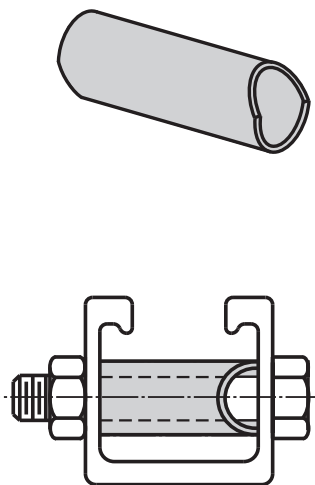

Used when attaching fittings to side walls of channel. This channel spacer prevents wall compression in heavy load conditions.

B217P PLASTIC CLOSURE STRIP

- Available in 10 Ft. (3.05 m) lengths.
- Material: PVC

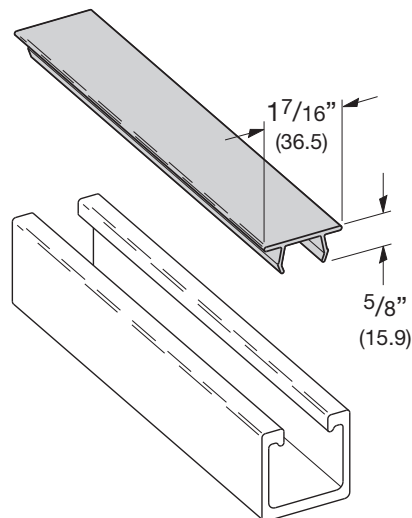

Reference page 182 for general fitting specifications.

Mini Channel & Fittings

Our mini channels and fittings provide for an economical method of supporting light load requirements on a metal framing system.

Channel

Channels are cold formed on our modern rolling mills from 18 Ga. (1.2 mm) low carbon steel strips plain steel (ASTM A1008 33,000 PSI min. yield) and pre-galvanized steel strips, (ASTM A653 33,000 PSI min. yield). A continuous slot with inturred lips provides the ability to make attachments at any point. Channel combinations are made with new state of the art, high-tech welding equipment.

Lengths

Standard lengths are 10' (3.05 m) and 20' (6.09 m) for B62 series, and 10' (3.05 m) for B72 series. Custom lengths are available.

Fittings

Mini fittings are formed from hot rolled pickled and oiled strip or sheet steel (ASTM A1011, HSLAS, Grade 50, Class1). The following dimensions apply to all fittings except as noted on the drawings:

Hole Size— $9/32$ " (7.14 mm) Dia.

Hole Spacing— $13/32$ " (10.3 mm) from end and $11/16$ " (27.0 mm) on center.

Width— $13/16$ " (20.6 mm)

Thickness— $1/8$ " (3.2 mm)

Materials & Finishes*

Finish Code	Finish	Specification
PLN	Plain	ASTM A1011, HSLAS, Grade 50, Class 1
ZN	Electro-Plated Zinc	ASTM B633 SC3 Type II
GRN	DURA-GREEN™	
GLV	Pre-Galvanized	ASTM A653 33,000 PSI min. yield
HDG	Hot-Dipped Galvanized	ASTM A123

*Unless otherwise noted.

Metric

Metric dimensions are shown in parentheses. Unless noted, all metric dimensions are in millimeters.



B62 Channel

- Thickness: 18 Ga. (1.2 mm)
- Standard lengths: 10' (3.05 m) & 20' (6.09 m)
- Standard finishes: Plain, DURA-GREEN™, Pre-Galvanized
- Weight: .42 Lbs./Ft. (.62 kg/m)

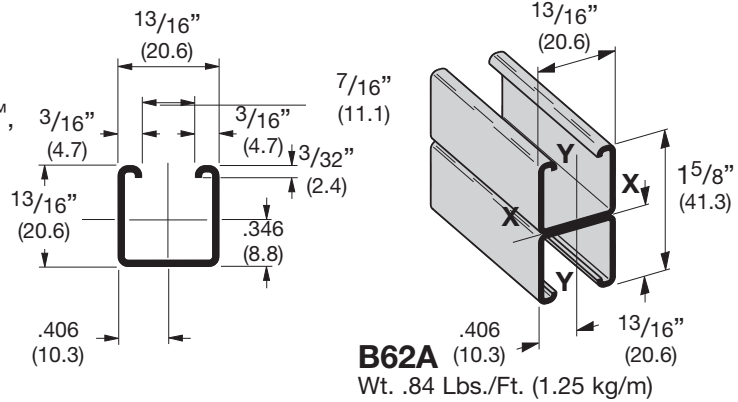
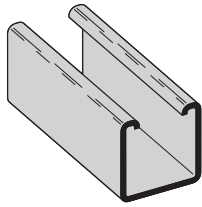

SECTION PROPERTIES

Channel	X - X Axis					Y - Y Axis				
	Weight lbs./ft. kg/m	Areas of Section sq. in. cm ²	Moment of Inertia (I) in. ⁴ cm ⁴	Section Modulus (S) in. ³ cm ³	Radius of Gyration (r) in. cm	Moment of Inertia (I) in. ⁴ cm ⁴	Section Modulus (S) in. ³ cm ³	Radius of Gyration (r) in. cm		
B62	.420 (.62)	.123 (.80)	.0103 (.43)	.0221 (.36)	.289 (.73)	.0134 (.56)	.0330 (.54)	.330 (.84)		
B62A	.839 (1.25)	.247 (1.59)	.0500 (2.08)	.0616 (1.01)	.450 (1.14)	.0269 (1.12)	.0663 (1.09)	.330 (.84)		

Calculations of section properties are based on metal thicknesses as determined by the AISI Cold-Formed Steel Design Manual.

BEAM LOADING

Beam Span In. mm	Channel Style	Uniform Load and Deflection				Uniform Load @ Deflection =			
		Lbs. kN	In. mm	1/240 Span	1/360 Span	Lbs. kN	Lbs. kN		
12 (305)	B62	364 (1.62)	.027 (.68)	364 (1.62)	364 (1.62)				
	B62A	420* (1.87)	.006 (.15)	420* (1.87)	420* (1.87)				
24 (609)	B62	182 (0.81)	.109 (2.77)	167 (0.74)	111 (0.49)				
	B62A	420* (1.87)	.051 (1.29)	420* (1.87)	420* (1.87)				
36 (914)	B62	121 (0.54)	.245 (6.22)	74 (0.33)	50 (0.22)				
	B62A	341 (1.51)	.141 (3.58)	341 (1.51)	242 (1.07)				
48 (1219)	B62	91 (0.40)	.436 (11.07)	42 (0.18)	28 (0.12)				
	B62A	256 (1.14)	.250 (6.35)	204 (0.91)	136 (0.60)				
60 (1524)	B62	73 (0.32)	.681 (17.30)	27 (0.12)	18 (0.08)				
	B62A	205 (0.91)	.391 (9.93)	131 (0.58)	87 (0.39)				
72 (1829)	B62	61 (0.27)	.981 (24.92)	19 (0.08)	12 (0.05)				
	B62A	170 (0.75)	.563 (14.30)	91 (0.40)	61 (0.27)				

Based on simple beam condition using an allowable design stress of 25,000 psi (172 MPa) in accordance with MFMA, with adequate lateral bracing (see page 11 for further explanation). Actual yield point of cold rolled steel is 42,000 psi. To determine concentrated load capacity at mid span, multiply uniform load by 0.5 and corresponding deflection by 0.8. *Failure determined by weld shear.

COLUMN LOADING

Unbraced Height In. mm	Channel Style	Max. Column Loading K = .80				Max. Column Loading (Loaded @ C.G.)					
		Loaded@ C.G.		Loaded@ Slot Face		K = .65		K = 1.0		K = 1.2	
		Lbs. kN	Lbs. kN	Lbs. kN	Lbs. kN	Lbs. kN	Lbs. kN	Lbs. kN	Lbs. kN		
12 (305)	B62	2052 (9.13)	820 (3.65)	2161 (9.61)	1890 (8.41)	1715 (7.63)					
	B62A	4666 (20.75)	1449 (6.44)	4710 (20.95)	4593 (20.43)	4503 (20.03)					
24 (609)	B62	1350 (6.00)	645 (2.87)	1624 (7.22)	1020 (4.54)	818 (3.64)					
	B62A	4275 (19.01)	1367 (6.08)	4453 (19.81)	3982 (17.71)	3624 (16.12)					
36 (914)	B62	818 (3.64)	471 (2.09)	1053 (4.68)	633 (2.81)	515 (2.29)					
	B62A	3624 (16.12)	847 (3.77)	4023 (17.89)	2965 (13.19)	2179 (9.69)					
48 (1219)	B62	589 (2.62)	369 (1.64)	745 (3.31)	456 (2.03)	365** (1.62)					
	B62A	2713 (12.06)	504 (2.24)	3421 (15.21)	1765 (7.85)	1225 (5.45)					
60 (1524)	B62	456 (2.03)	300 (1.33)	579 (2.57)	347** (1.54)	271** (1.20)					
	B62A	1765 (7.85)	323 (1.44)	2647 (11.77)	1129 (5.02)	784** (3.49)					
72 (1829)	B62	365** (1.62)	248 (1.10)	470 (2.09)	271** (1.20)	-					
	B62A	1225 (5.45)	224 (0.99)	1856 (8.25)	784** (3.49)	545** (2.42)					

**Where the slenderness ratio $\frac{KL}{r}$ exceeds 200, and K = end fixity factor, L = actual length and r = radius of gyration.

Reference page 200 for general fitting specifications.

B72 Channel

- Thickness: 18 Ga. (1.2 mm)
- Standard lengths: 10' (3.05 m)
- Standard finishes: Plain, DURA-GREEN™, Pre-Galvanized
- Weight: .29 Lbs./Ft. (.43 kg/m)

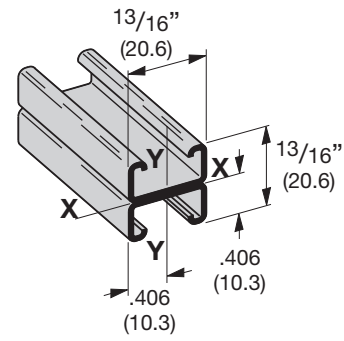
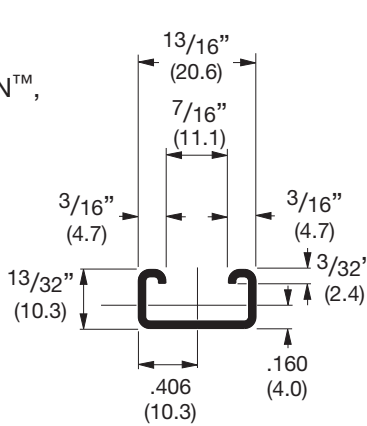
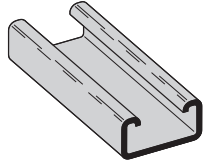

B72A
Wt. .58 Lbs./Ft. (.87 kg/m)

SECTION PROPERTIES

Channel	Weight		Areas of Section		Moment of Inertia (I)		Section Modulus (S)		Radius of Gyration (r)		X - X Axis				Y - Y Axis			
											Moment of Inertia (I)		Section Modulus (S)		Radius of Gyration (r)			
B72	.287	(.43)	.084	(.54)	.0018	(.07)	.0073	(.12)	.146	(.37)	.0077	(.32)	.0190	(.31)	.302	(.77)		
B72A	.574	(.85)	.169	(1.09)	.0078	(.32)	.0192	(.31)	.215	(.55)	.0155	(.65)	.0382	(.63)	.303	(.77)		

Calculations of section properties are based on metal thicknesses as determined by the AISI Cold-Formed Steel Design Manual.

BEAM LOADING

Beam Span	Channel	Uniform Load and Deflection				Uniform Load @ Deflection =			
		Lbs.	kN	In.	mm	1/240 Span	1/360 Span	Lbs.	kN
12	B72 B72A	116	(0.51)	.051	(1.29)	113	(0.50)	75	(0.32)
		210*	(0.93)	.020	(.51)	210*	(0.93)	210*	(0.93)
24	B72 B72A	58	(0.26)	.206	(5.23)	28	(0.12)	19	(0.08)
		159	(0.71)	.125	(3.17)	127	(0.56)	85	(0.38)
36	B72 B72A	39	(0.17)	.465	(11.81)	13	(0.06)	8	(0.03)
		106	(0.45)	.281	(7.14)	57	(0.25)	38	(0.17)
36	B72 B72A	29	(0.13)	.827	(21.00)	7	(0.03)	5	(0.02)
		80	(0.35)	.500	(12.70)	32	(0.14)	21	(0.09)
60	B72 B72A	23	(0.10)	1.292	(32.81)	5	(0.02)	3	(0.01)
		64	(0.28)	.782	(19.86)	20	(0.09)	14	(0.06)

Based on simple beam condition using an allowable design stress of 25,000 psi (172 MPa) in accordance with MFMA, with adequate lateral bracing (see page 11 for further explanation). Actual yield point of cold rolled steel is 42,000 psi. To determine concentrated load capacity at mid span, multiply uniform load by 0.5 and corresponding deflection by 0.8. *Failure determined by weld shear.

COLUMN LOADING

Unbraced Height	Channel Style	Max. Column Loading K = .80				Max. Column Loading (Loaded @ C.G.)					
		Loaded @ C.G.		Loaded @ Slot Face		K = .65		K = 1.0		K = 1.2	
		Lbs.	kN	Lbs.	kN	Lbs.	kN	Lbs.	kN	Lbs.	kN
12	B72 B72A	1598	(7.11)	539	(2.40)	1712	(7.61)	1410	(6.27)	1181	(5.25)
		3600	(16.01)	986	(4.38)	3700	(16.46)	3433	(15.27)	3229	(14.36)
24	B72 B72A	701	(3.12)	320	(1.42)	1050	(4.67)	450	(2.00)	313**	(1.39)
		2710	(12.05)	802	(3.57)	3113	(13.85)	2043	(9.09)	1421	(6.32)
36	B72 B72A	313**	(1.39)	188	(0.83)	473	(2.10)	201**	(0.89)	-	-
		1421	(6.32)	569	(2.53)	2135	(9.50)	909	(4.04)	631**	(2.81)
36	B72 B72A	177**	(0.79)	122	(0.54)	267**	(1.19)	-	-	-	-
		799	(3.55)	404	(1.80)	1211	(5.39)	512**	(2.28)	355**	(1.58)
60	B72 B72A	113**	(0.50)	85	(0.38)	171**	(0.76)	-	-	-	-
		512**	(2.28)	298	(1.32)	775	(3.45)	327**	(1.45)	-	-

**Where the slenderness ratio $\frac{KL}{r}$ exceeds 200, and K = end fixity factor, L = actual length and r = radius of gyration.

Reference page 200 for general fitting specifications.

Mini Channel Nuts & Fittings

NUTS FOR B62, B72 CHANNEL

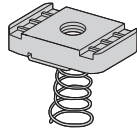

SPRING NUT

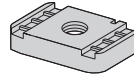

NUT WITHOUT SPRING

Part Number				Thread Size	Thickness		Wt./C	
B62		B72						
With Spring	Without Spring	With Spring	Without Spring				Lbs.	kg
N621	N621WO	N7221	N621WO	#8-32	.150	(3.81)	1.0	(.45)
N622	N622WO	N7222	N622WO	#10-24	.150	(3.81)	1.0	(.45)
N627	N627WO	N7227	N627WO	#10-32	.150	(3.81)	1.0	(.45)
N624	N624WO	N7224	N624WO	1/4-20	.150	(3.81)	1.0	(.45)
BMM-3L	BMM-3	BMM-3S	BMM-3	M3.5 x 0.6	.150	(3.81)	1.0	(.45)
BMM-4L	BMM-4	BMM-4S	BMM-4	M4 x 0.7	.150	(3.81)	1.0	(.45)
BMM-5L	BMM-5	BMM-5S	BMM-5	M5 x 0.8	.150	(3.81)	1.0	(.45)
BMM-6L	BMM-6	BMM-6S	BMM-6	M6 x 1	.150	(3.81)	1.0	(.45)

Mini Channel & Fittings

MINI FITTINGS

B6202 SQUARE WASHER

- Standard finishes: ZN, GRN
- Wt./C 2 Lbs. (.9 kg)

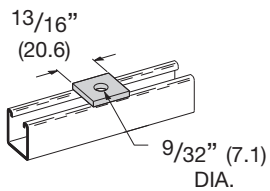

B6129 TWO HOLE SPLICE PLATE

- Standard finishes: ZN, GRN
- Wt./C 5 Lbs. (2.2 kg)

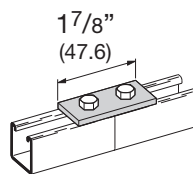

B6340 TWO HOLE SPLICE PLATE

- Standard finishes: ZN, GRN
- Wt./C 5 Lbs. (2.2 kg)

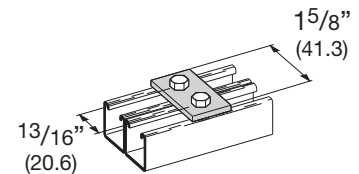

Reference page 200 for general fitting specifications.

Mini Fittings

B6141 THREE HOLE SPLICE PLATE

- Standard finishes: ZN, GRN
- Wt./C 7 Lbs. (3.2 kg)

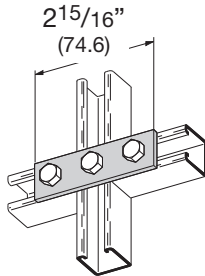

B600-62 THREE HOLE FLAT ADAPTER PLATE

- Standard finishes: ZN, GRN
- Wt./C 19 Lbs. (8.6 kg)

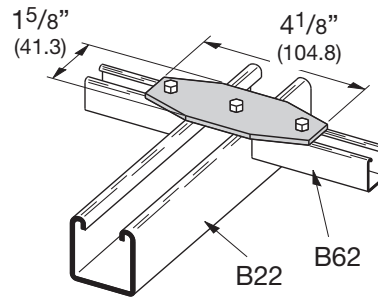

B6557 THREE HOLE SPLICE PLATE

- Standard finishes: ZN, GRN
- Wt./C 7 Lbs. (3.2 kg)

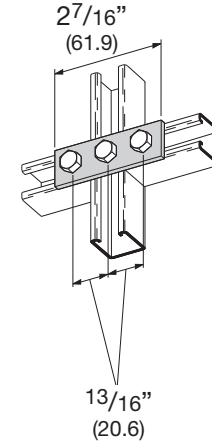

B6341 FOUR HOLE SPLICE PLATE

- Standard finishes: ZN, GRN
- Wt./C 11 Lbs. (5.0 kg)

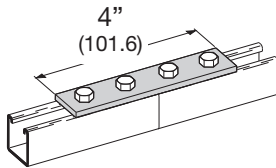

B6138 TWO HOLE SWIVEL PLATE

- Standard finishes: ZN, GRN
- Wt./C 7 Lbs. (3.2 kg)

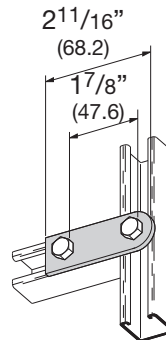

B6139 THREE HOLE SWIVEL PLATE

- Standard finishes: ZN, GRN
- Wt./C 10 Lbs. (4.5 kg)

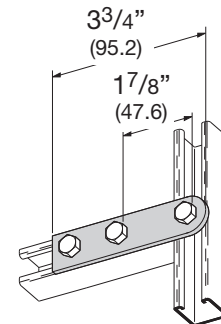

B6504 FOUR HOLE SPLICE PLATE

- Standard finishes: ZN, GRN
- Wt./C 10 Lbs. (4.5 kg)

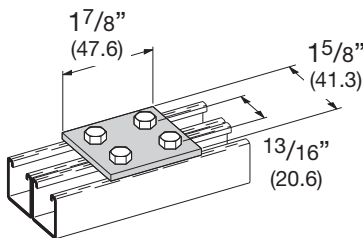

B6140 THREE HOLE CORNER PLATE

- Standard finishes: ZN, GRN
- Wt./C 8 Lbs. (3.6 kg)

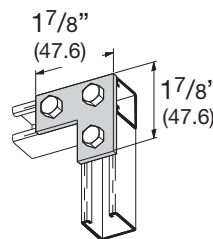

B6143 FOUR HOLE CORNER PLATE

- Standard finishes: ZN, GRN
- Wt./C 11 Lbs. (5.0 kg)

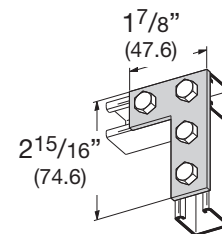

Reference page 200 for general fitting specifications.

B6133
FOUR HOLE TEE PLATE

- Standard finishes: ZN, GRN
- Wt./C 11 Lbs. (5.0 kg)

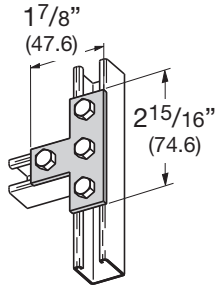

B6132
FIVE HOLE CROSS PLATE

- Standard finishes: ZN, GRN
- Wt./C 13 Lbs. (5.9 kg)

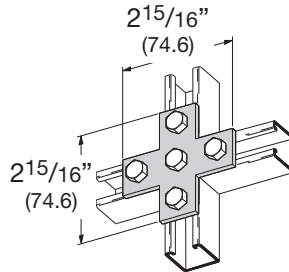

B6135
THREE HOLE CORNER GUSSET PLATE

- Standard finishes: ZN, GRN
- Wt./C 9 Lbs. (4.1 kg)

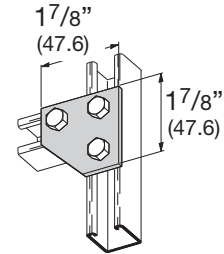

B6142
FOUR HOLE CORNER GUSSET PLATE

- Standard finishes: ZN, GRN
- Wt./C 15 Lbs. (6.8 kg)

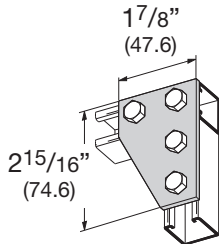

B6337
THREE HOLE TEE GUSSET PLATE

- Standard finishes: ZN, GRN
- Wt./C 10 Lbs. (4.5 kg)

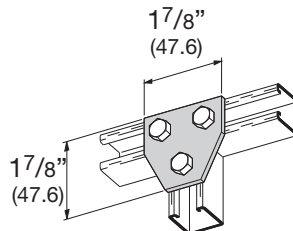

B6136
FOUR HOLE TEE GUSSET PLATE

- Standard finishes: ZN, GRN
- Wt./C 15 Lbs. (6.8 kg)

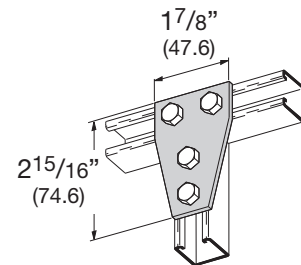

B6532
FIVE HOLE TEE GUSSET PLATE

- Standard finishes: ZN, GRN
- Wt./C 22 Lbs. (10.0 kg)

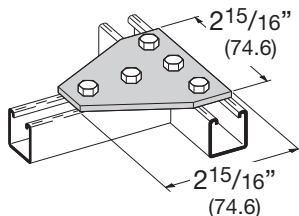

B6101
TWO HOLE CORNER ANGLE

- Standard finishes: ZN, GRN
- Wt./C 5 Lbs. (2.2 kg)

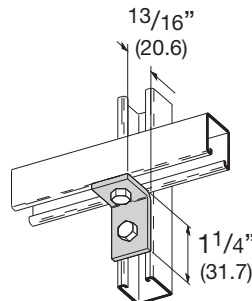

B6230
TWO HOLE CORNER ANGLE

- Standard finishes: ZN, GRN
- Wt./C 5 Lbs. (2.2 kg)

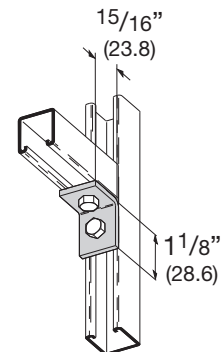

Reference page 200 for general fitting specifications.

Mini Fittings

B6102 THREE HOLE CORNER ANGLE

- Standard finishes: ZN, GRN
- Wt./C 8 Lbs. (3.6 kg)

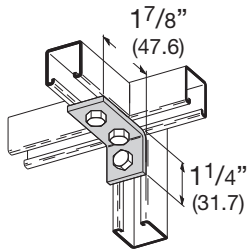

B6103 THREE HOLE CORNER ANGLE

- Standard finishes: ZN, GRN
- Wt./C 8 Lbs. (3.6 kg)

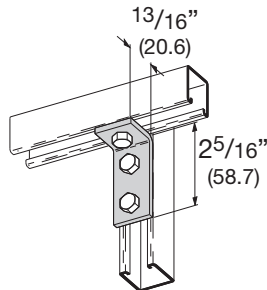

B6232 THREE HOLE CORNER ANGLE

- Standard finishes: ZN, GRN
- Wt./C 7 Lbs. (3.2 kg)

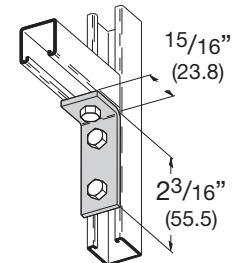

B6374 THREE HOLE CORNER ANGLE

- Standard finishes: ZN, GRN
- Wt./C 7 Lbs. (3.2 kg)

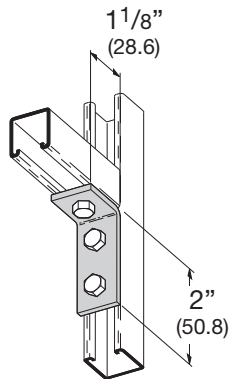

B6104 FOUR HOLE CORNER ANGLE

- Standard finishes: ZN, GRN
- Wt./C 10 Lbs. (4.5 kg)

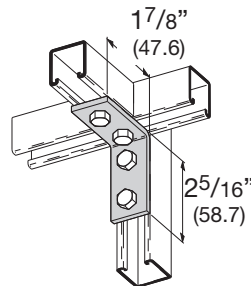

B6558 FOUR HOLE CORNER ANGLE

- Standard finishes: ZN, GRN
- Wt./C 10 Lbs. (4.5 kg)

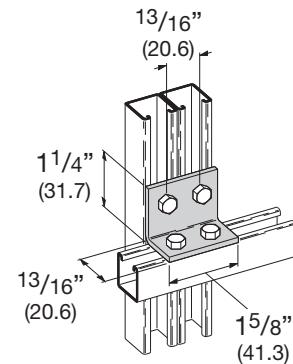

B6357 FOUR HOLE OFFSET BENT TEE

- Standard finishes: ZN, GRN
- Wt./C 11 Lbs. (5.0 kg)

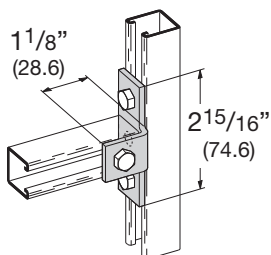

B6239 FIVE HOLE OFFSET BENT TEE

- Standard finishes: ZN, GRN
- Wt./C 14 Lbs. (6.3 kg)

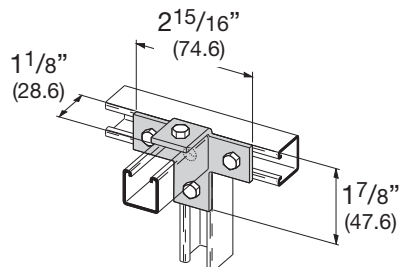

B6144R&L FOUR HOLE SHELF BRACKET

- Standard finishes: ZN, GRN
- Wt./C 19 Lbs. (8.6 kg)

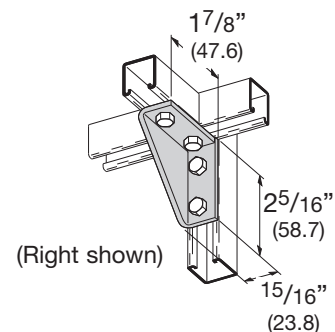

Reference page 200 for general fitting specifications.

B6134R&L FOUR HOLE CORNER GUSSET

- Standard finishes: ZN, GRN
- Wt./C 15 Lbs. (6.8 kg)

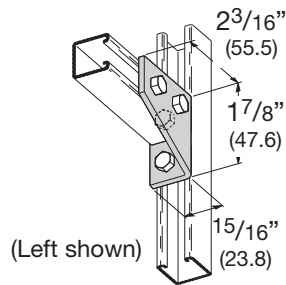

B6234 R&L FOUR HOLE CORNER GUSSET

- Standard finishes: ZN, GRN
- Wt./C 15 Lbs. (6.8 kg)

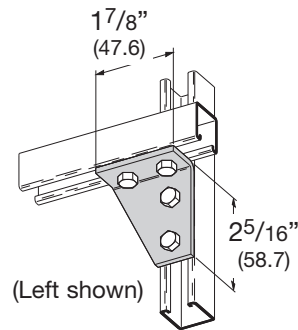

B6118 FOUR HOLE GUSSETED SHELF ANGLE

- Standard finishes: ZN, GRN
- Wt./C 15 Lbs. (6.8 kg)

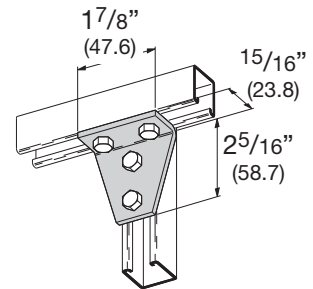

B6533 FIVE HOLE GUSSETED SHELF ANGLE

- Standard finishes: ZN, GRN
- Wt./C 22 Lbs. (10.0 kg)

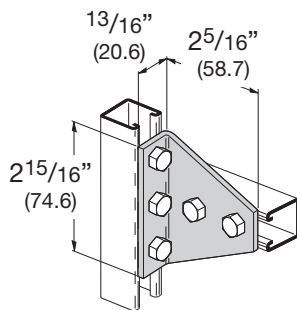

B6126 FOUR HOLE GUSSETED THREE WAY SHELF ANGLE

- Standard finishes: ZN, GRN
- Wt./C 15 Lbs. (6.8 kg)

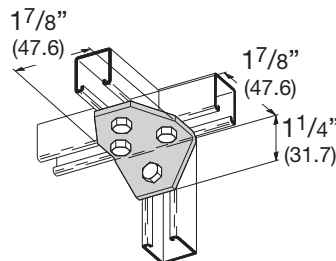

B6127 FIVE HOLE GUSSETED THREE WAY SHELF ANGLE

- Standard finishes: ZN, GRN
- Wt./C 18 Lbs. (8.1 kg)

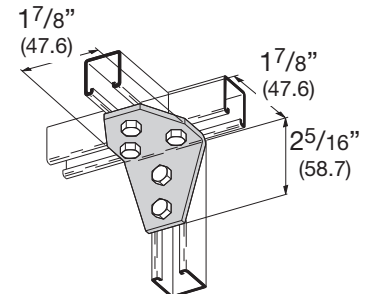

B6112 FOUR HOLE ADJUSTABLE CORNER ANGLE

- Standard finishes: ZN, GRN
- Wt./C 32Lbs. (14.5 kg)

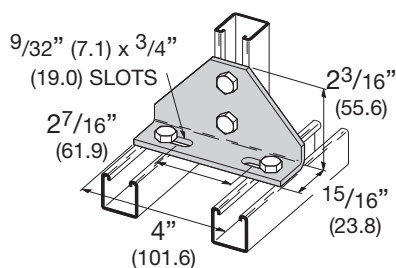

B589-62 TWO HOLE 90° ADAPTER ANGLE

- Standard finishes: ZN, GRN
- Wt./C 11 Lbs. (5.0 kg)

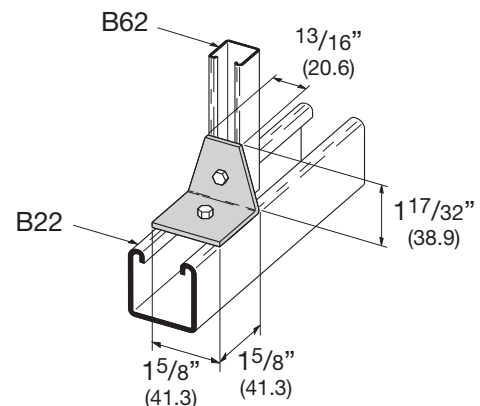

Reference page 200 for general fitting specifications.

Mini Fittings

B6147-B6152 TWO HOLE OPEN ANGLE

- Standard finishes: ZN, GRN

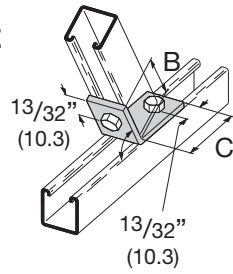

Part No.	A	B	C	Wt./C	
				Lbs.	kg
B6147	82 ¹ / ₂ °	2 ¹ / ₃₂ " (51.6)	2 ⁷ / ₃₂ " (21.4)	8.0	(3.6)
B6148	75°	2 ¹ / ₃₂ " (51.6)	2 ⁷ / ₃₂ " (21.4)		
B6149	67 ¹ / ₂ °	2" (50.8)	7 ⁷ / ₈ " (22.2)		
B6150	60°	1 ³¹ / ₃₂ " (50.0)	1 ⁵ / ₁₆ " (23.8)		
B6151	52 ¹ / ₂ °	1 ⁷ / ₈ " (47.6)	1 ¹ / ₁₆ " (27.0)		
B6152	37 ¹ / ₂ °	2" (50.8)	2 ⁹ / ₃₂ " (23.0)		

B6154 TWO HOLE OPEN ANGLE

- Standard finishes: ZN, GRN
- Wt./C 8 Lbs. (3.6 kg)

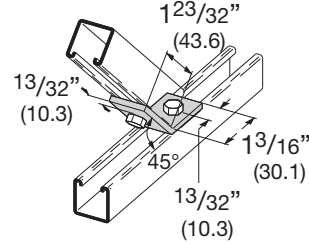

B6162-B6165 TWO HOLE OPEN ANGLE

- Standard finishes: ZN, GRN

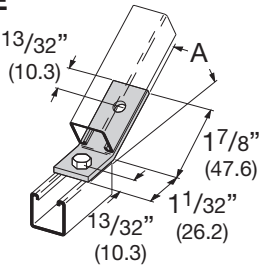

Part No.	A	Wt./C	
		Lbs.	kg
B6162	30°	8.0	(3.6)
B6163	22 ¹ / ₂ °		
B6164	15°		
B6165	7 ¹ / ₂ °		

B6156-B6161 TWO HOLE CLOSED ANGLE

- Standard finishes: ZN, GRN

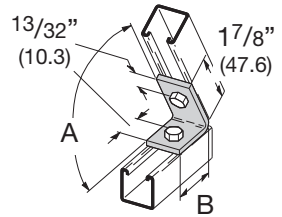

Part No.	A	B	Wt./C	
			Lbs.	kg
B6156	82 ¹ / ₂ °	1 ⁹ / ₃₂ " (32.5)	8.0	(3.6)
B6157	75°	1 ⁵ / ₁₆ " (33.3)		
B6158	67 ¹ / ₂ °	1 ³ / ₈ " (34.9)		
B6159	60°	1 ¹³ / ₃₂ " (35.7)		
B6160	52 ¹ / ₂ °	1 ¹⁵ / ₃₂ " (37.3)		
B6161	37 ¹ / ₂ °	1 ²¹ / ₃₂ " (42.0)		

B6155 TWO HOLE CLOSED ANGLE

- Standard finishes: ZN, GRN
- Wt./C 8 Lbs. (3.6 kg)

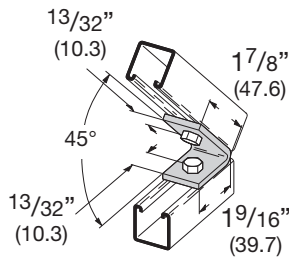

B601-62 TWO HOLE 45° ADAPTER ANGLE

- Standard finishes: ZN, GRN
- Wt./C 14 Lbs. (6.3 kg)

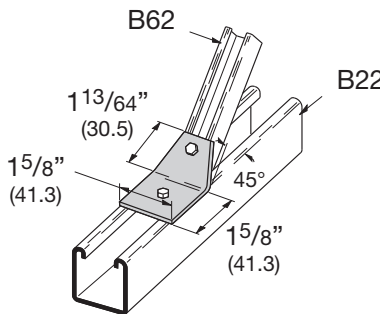

B6169 TWO HOLE SPLICE CLEVIS FOR B72

- Standard finishes: ZN, GRN
- Wt./C 11 Lbs. (5.0 kg)

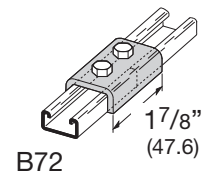

Reference page 200 for general fitting specifications.

B6168
THREE HOLE SPLICE CLEVIS FOR B72

- Standard finishes: ZN, GRN
- Wt./C 16 Lbs. (7.2 kg)

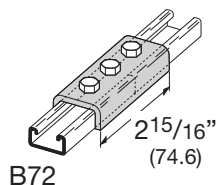

B6167
FOUR HOLE SPLICE CLEVIS FOR B72

- Standard finishes: ZN, GRN
- Wt./C 24 Lbs. (10.9 kg)

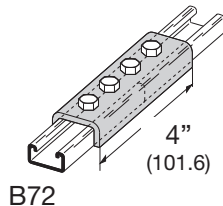

B6170
TWO HOLE SPLICE CLEVIS FOR B62

- Standard finishes: ZN, GRN
- Wt./C 17 Lbs. (7.7 kg)

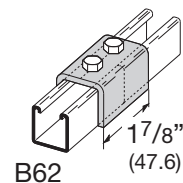

B6171
THREE HOLE SPLICE CLEVIS FOR B62

- Standard finishes: ZN, GRN
- Wt./C 26 Lbs. (11.8 kg)

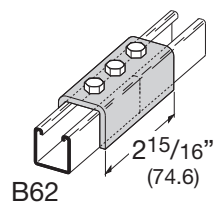

B6172
FOUR HOLE SPLICE CLEVIS FOR B62

- Standard finishes: ZN, GRN
- Wt./C 36 Lbs. (16.3 kg)

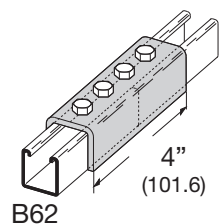

B7116
THREE HOLE U-SUPPORT

- Standard finishes: ZN, GRN
- Wt./C 10 Lbs. (4.5 kg)

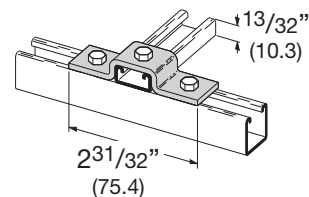

B6107
THREE HOLE U-SUPPORT

- Standard finishes: ZN, GRN
- Wt./C 12 Lbs. (5.4 kg)

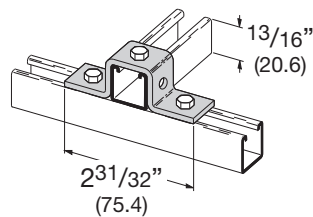

B6107-62A
THREE HOLE U-SUPPORT

- Standard finishes: ZN, GRN
- Wt./C 16 Lbs. (7.2 kg)

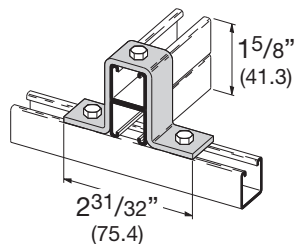

B6594
FIVE HOLE U-SUPPORT

- Standard finishes: ZN, GRN
- Wt./C 13 Lbs. (5.9 kg)

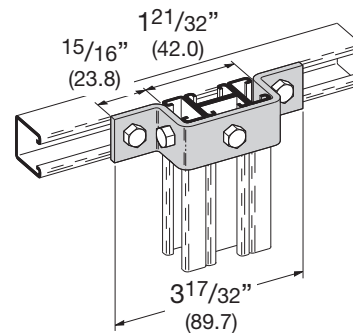

Reference page 200 for general fitting specifications.

Mini Fittings

B6173 FOUR HOLE CLEVIS

- Standard finishes: ZN, GRN
- Wt./C 9 Lbs. (4.1 kg)

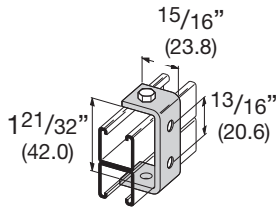

B6526 TWO HOLE OFFSET Z-SUPPORT

- Standard finishes: ZN, GRN
- Wt./C 5 Lbs. (2.2 kg)

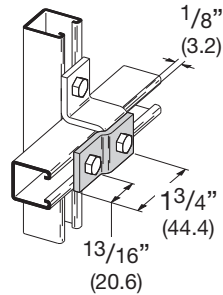

B6105 TWO HOLE Z-SUPPORT FOR B62

- Standard finishes: ZN, GRN
- Wt./C 7 Lbs. (3.2 kg)

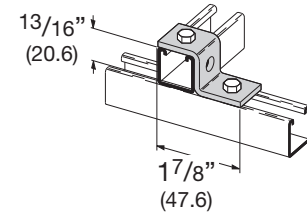

B7105 TWO HOLE Z-SUPPORT FOR B72

- Standard finishes: ZN, GRN
- Wt./C 7 Lbs. (3.2 kg)

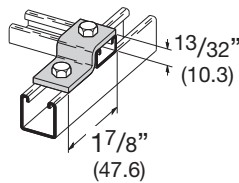

B6110 TWO HOLE Z-SUPPORT FOR B62A

- Standard finishes: ZN, GRN
- Wt./C 9 Lbs. (4.1 kg)

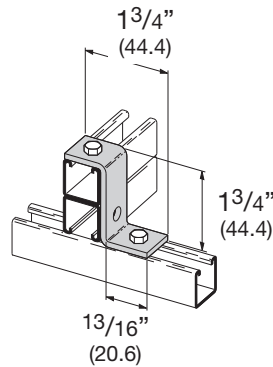

B6108 TWO HOLE OFFSET Z-SUPPORT

- Standard finishes: ZN, GRN
- Wt./C 7 Lbs. (3.2 kg)

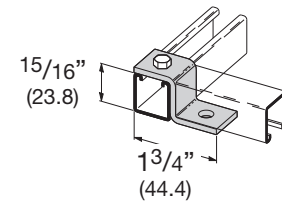

B598-62 TWO HOLE Z-ADAPTER PLATE

- Standard finishes: ZN, GRN
- Wt./C 28 Lbs. (12.7 kg)

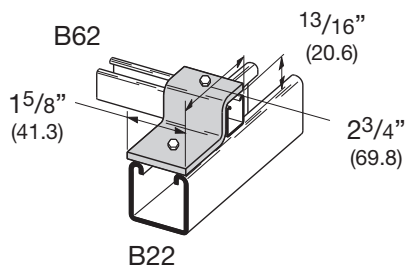

B6571 EIGHT HOLE WING CONNECTION

- Standard finishes: ZN, GRN
- Wt./C 28 Lbs. (12.7 kg)

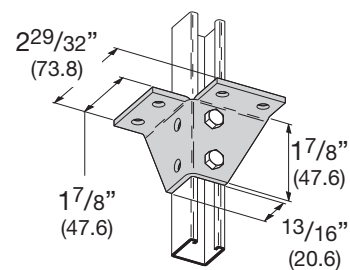

Reference page 200 for general fitting specifications.

B6205 END CAP FOR B62

- Material: ASTM A1008 SS Gr. 33 Type 1
- Standard finishes: ZN, GRN
- Wt./C 3 Lbs. (1.3 kg)

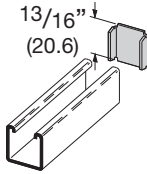

B7205 END CAP FOR B72

- Material: ASTM A1008 SS Gr. 33 Type 1
- Standard finishes: ZN, GRN
- Wt./C 1 Lb. (.4 kg)

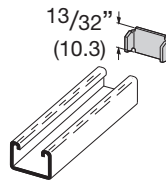

B6211 Z-BEAM CLAMP

- 5/16"-18 Setscrew included
- 13/16" (20.6) Max. Flange Thickness
- Material: ASTM A36
- Standard finishes: ZN, GRN
- Wt./C 13 Lbs. (5.9 kg)

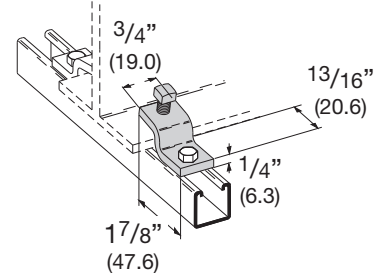

B6409-6, 9 BRACKET

- Safety Factor of 2
- Uniform Design Load 40 Lbs. (.18 kN)
- Standard finishes: ZN, GRN

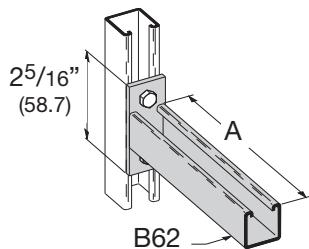

Part No.	A	Wt./C	
		Lbs.	kg
B6409-6	6"	(152.4)	28.0 (12.7)
B6409-9	9"	(228.6)	35.0 (15.8)

B2350-B2355 ONE HOLE DOUBLE TUBING STRAP

- Material: ASTM A1008 SS Gr. 33 Type 1
- Standard finishes: ZN, GRN

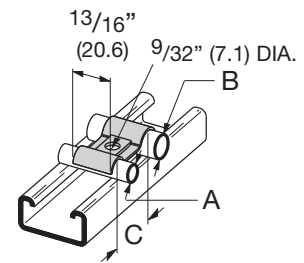

Part No.	O.D. Size A		O.D. Size B		O.D. Size C		Wt./C	
	Lbs.	kg	Lbs.	kg	Lbs.	kg	Lbs.	kg
B2350	1/4"	(6.3)	1/4"	(6.3)	3/4"	(19.0)	1.2	(.5)
B2351	3/8"	(9.5)	3/8"	(9.5)	1"	(25.4)	2.0	(.9)
B2352	1/2"	(12.7)	1/2"	(12.7)	1 1/4"	(31.7)	2.9	(1.3)
B2353	1/4"	(6.3)	3/8"	(9.5)	7/8"	(22.2)	1.6	(.7)
B2354	1/4"	(6.3)	1/2"	(12.7)	1"	(25.4)	2.1	(.9)
B2355	3/8"	(9.5)	1/2"	(12.7)	1 1/8"	(28.6)	2.5	(1.1)

B2308-B2315 ONE HOLE TUBING STRAP

- Material: Sizes 1/4" - 1/2", ASTM A611 Gr. C 5/8" - 1", ASTM A1008 SS Gr. 33 Type 1
- Standard finishes: ZN, GRN

Part No.	O.D. Size A		O.D. Size B		C	Wt./C	
	Lbs.	kg	Lbs.	kg		Lbs.	kg
B2308	1/4"	(6.3)	1 1/32"	(26.2)	.048 (1.2)	1.2	(.5)
B2309	5/16"	(7.9)	1 3/32"	(27.8)	.048 (1.2)	1.4	(.6)
B2310	3/8"	(9.5)	1 3/16"	(30.1)	.048 (1.2)	1.6	(.7)
B2311	1/2"	(12.7)	1 21/64"	(33.7)	.048 (1.2)	1.9	(.8)
B2312	5/8"	(15.9)	1 25/64"	(35.3)	.062 (1.6)	2.7	(1.2)
B2313	3/4"	(19.0)	1 39/64"	(40.9)	.075 (1.9)	4.3	(1.9)
B2314	7/8"	(22.2)	1 51/64"	(45.6)	.075 (1.9)	4.9	(2.2)
B2315	1"	(25.4)	2 1/32"	(51.6)	.075 (1.9)	5.2	(2.3)

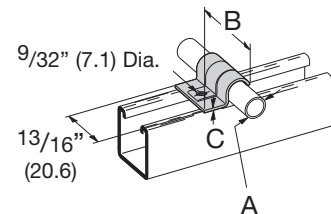

Reference page 200 for general fitting specifications.

Continuous Concrete Inserts

Continuous slot Concrete Inserts are designed to provide a pre-set support system cast in concrete ceilings, walls, and floors to allow flexibility of attachment at any point along the channel. This provides an excellent support system for pipe, conduit, and cable trays.

Continuous Concrete Inserts, manufactured from Our standard channels, have formed anchors spaced on 4 inch (101.6 mm) centers. $\frac{3}{16}$ " (4.8 mm) nail-holes are provided for securing the inserts to the forms.

Available in lengths from 3 inches (7.62 cm) to 240 inches (609.6 cm), Concrete Inserts are shipped complete with end caps and styrofoam filler strips which prevent seepage of concrete into the insert. Styrofoam is easily removed by pulling the convenient pull-tab.

Materials & Finishes*

Finish Code	Finish	Specification
PLN	Plain	ASTM A1011 33,000 PSI min. yield
GRN	DURA-GREEN™	
ZN	Electro-Plated Zinc	ASTM B633 SC1 Type III
GALV	Pre-Galvanized	ASTM A653 33,000 PSI min. yield
HDG	Hot-Dipped Galvanized	ASTM A123
SS4	Stainless Steel Type 304	ASTM A240
SS6	Stainless Steel Type 316	ASTM A240

*Unless otherwise noted.



Spot Inserts

B-Line's Spot Inserts provide for economical single attachment points with full flexibility of fastener sizing, but with limited adjustment. These products are made from steel strips in accordance with ASTM A1011, 33,000 PSI min. yield. Standard finish is electro-plated zinc (ASTM B633).

Special Concrete Inserts

Pre-stressed inserts, inserts with studs welded to the back of the channel, and other types of special inserts are available from B-Line.

Test Data

Independent Testing Laboratory test data available upon request.

Metric

Metric dimensions are shown in parentheses. Unless noted, all metric dimensions are in millimeters.

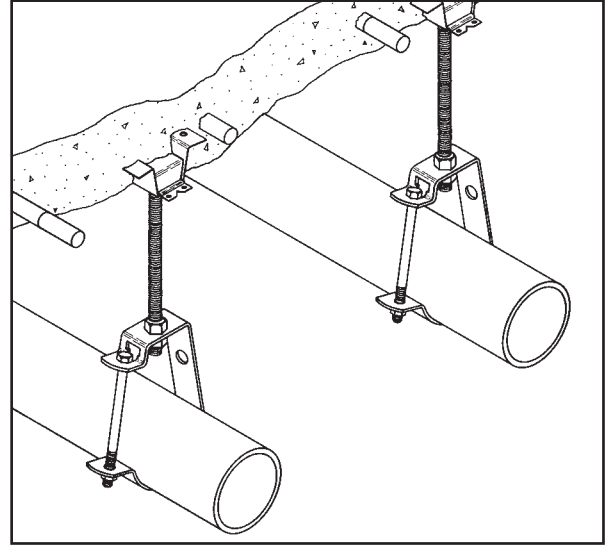
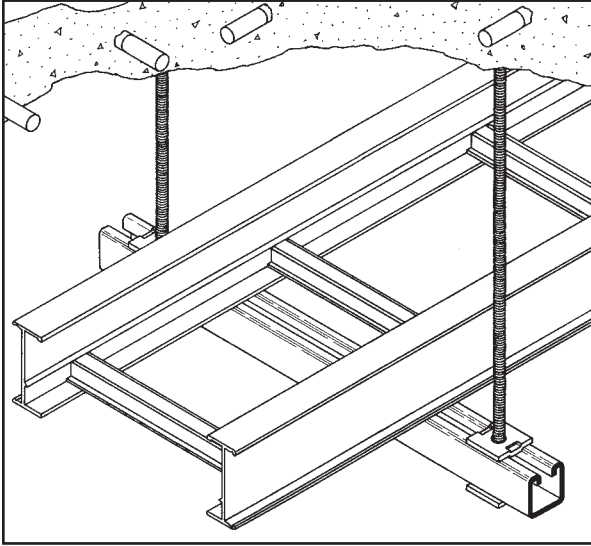

Continuous concrete inserts, installed in the ceiling, can be used to support trapeze hangers, suspended pipe racks, cable trays and single or multiple pipe hangers.

When installed in walls, continuous concrete inserts can be used as a support for tunnel stanchions, equipment braces, brackets and pipe racks.

Use spot inserts for single pipe-support or trapeze type hangers. Spot Inserts offer full flexibility of rod and fastener sizings.

B-Line Channel can be attached to continuous concrete inserts in walls or ceilings. Channel can also be attached to concrete walls and floors with expansion anchors.

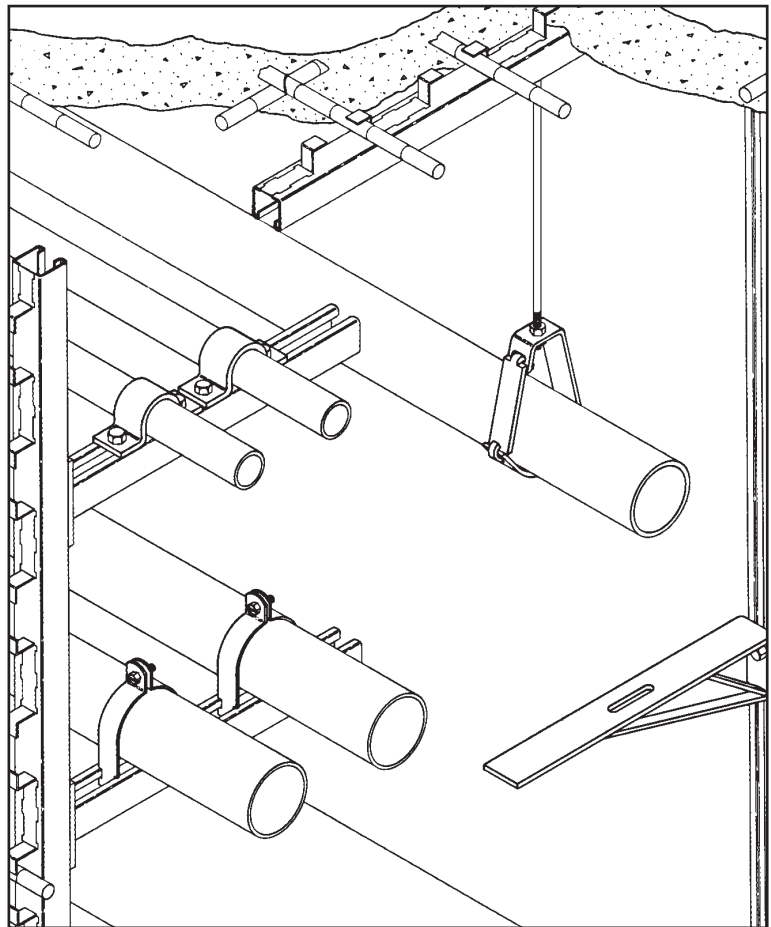

Reference page 212 for general fitting and standard finish specifications.

Continuous Concrete Inserts

B22I CONTINUOUS CONCRETE INSERT

- Design Load for B22-I-12 thru B22-I-240 is 2,000 lbs. (8.89 kN) per foot of concrete insert length with safety factor of 3 in 3000 psi concrete.
- Loads concentrated within the last 2 inches (50.8 mm) of concrete inserts 8" (203.2 mm) and longer should not exceed 1,000 lbs. (4.45kN).
- Concrete insert should be secured to the forms on 16" (406.4 mm) to 24" (609.6 mm) intervals.
- B22-I continuous concrete inserts are made from B22 channel. Use channel nuts designed for use in B22 channel.
- B22-I concrete inserts are supplied with styrofoam fillers. B3322 end caps are furnished with inserts through 8" (203.2 mm) long, and B205 end caps are furnished with inserts 12" (304.8 mm) and longer.
- Material: Plain Steel ASTM A1011 33,000 PSI min. yield or Pre-Galvanized Steel ASTM A653SS 33,000 PSI min. yield.
- Finish: Plain, DURA-GREEN™, Pre-Galv, HDG

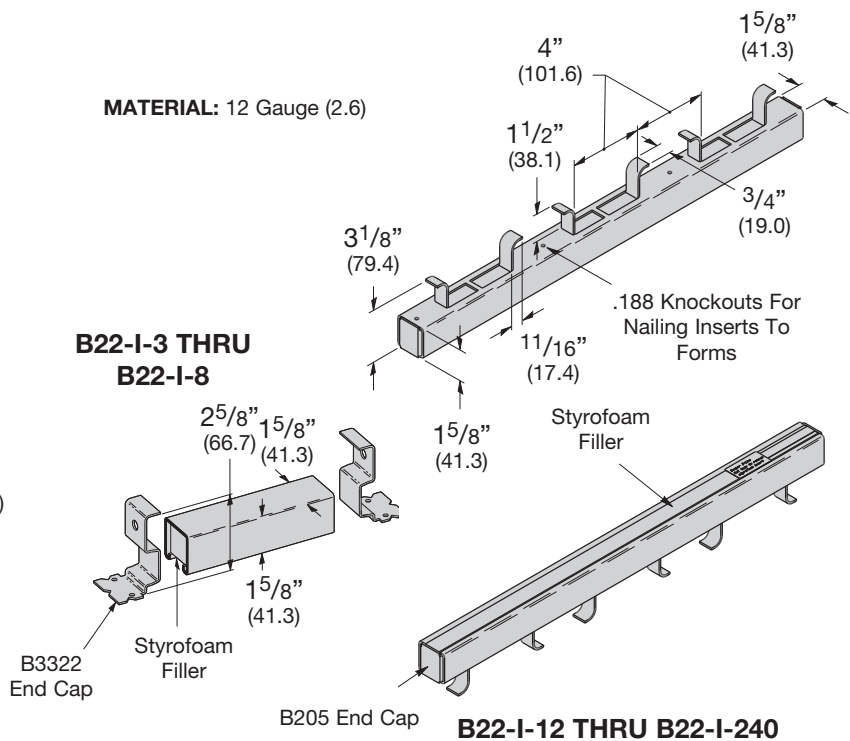

Part No.	Length		Wt./C		Design Load	
	in.	mm	Lbs.	kg	Lbs.	kN
B22-I-3	3"	(76)	72	(32.6)	500	(2.22)
B22-I-4	4"	(101)	88	(39.9)	800	(3.56)
B22-I-6	6"	(152)	120	(54.4)	1000	(4.45)
B22-I-8	8"	(203)	152	(68.9)	1200	(5.34)

Part No.	Length		Wt./C	
	in.	mm	Lbs.	kg
B22-I-12	12"	(305)	224	(101.6)
B22-I-16	16"	(406)	289	(131.1)
B22-I-20	20"	(508)	353	(160.1)
B22-I-24	24"	(609)	420	(190.5)
B22-I-32	32"	(813)	553	(250.8)
B22-I-36	36"	(914)	620	(281.2)
B22-I-40	40"	(1016)	686	(311.1)
B22-I-48	48"	(1219)	820	(371.9)
B22-I-60	60"	(1524)	1018	(461.7)
B22-I-72	72"	(1829)	1218	(552.5)
B22-I-84	84"	(2133)	1417	(642.7)
B22-I-96	96"	(2438)	1616	(733.0)
B22-I-108	108"	(2743)	1816	(823.7)
B22-I-120	120"	(3048)	2016	(914.4)
B22-I-144	144"	(3657)	2416	(1095.9)
B22-I-168	168"	(4267)	2816	(1277.3)
B22-I-192	192"	(4877)	3216	(1458.7)
B22-I-216	216"	(5486)	3616	(1640.2)
B22-I-240	240"	(6096)	4016	(1821.6)

Concrete Inserts

Reference page 212 for general fitting and standard finish specifications

Continuous Concrete Inserts

B32I CONTINUOUS CONCRETE INSERT

- Design Load for B32-I-12 thru B32-I-240 is 2,000 lbs. (8.89 kN) per foot of concrete insert length with safety factor of 3 in 3000 psi concrete.
- Loads concentrated within the last 2 inches (50.8 mm) of concrete inserts 8" (203.2 mm) and longer should not exceed 1,000 lbs. (4.45kN).
- Concrete insert should be secured to the forms on 16" (406.4 mm) to 24" (609.6 mm) intervals.
- B32-I continuous concrete inserts are made from B32 channel. Use channel nuts designed for use in B32 channel.
- B32-I concrete inserts are supplied with styrofoam fillers. B3332 end caps are furnished with inserts through 8" (203.2 mm) long, and B206 end caps are furnished with inserts 12" (304.8 mm) and longer.
- Material: Plain Steel ASTM A1011 33,000 PSI min. yield or Pre-Galvanized Steel ASTM A653SS 33,000 PSI min. yield.
- Finish: Plain, DURA-GREEN™, Pre-Galv, HDG

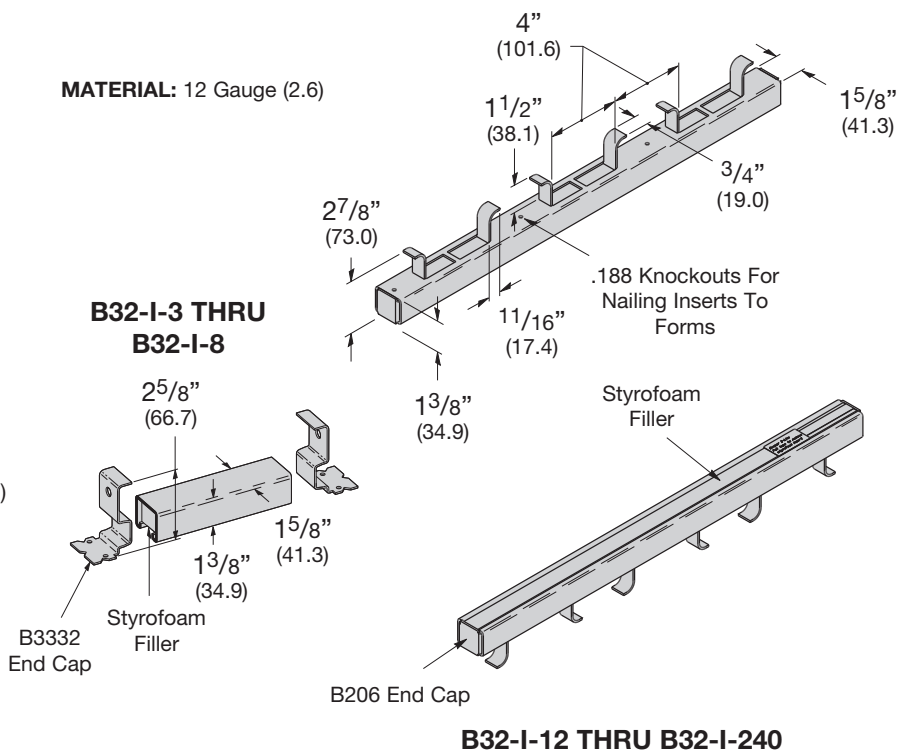

Part No.	Length		Wt./C		Design Load	
	in.	mm	Lbs.	kg	Lbs.	kN
B32-I-3	3"	(76)	65	(29.5)	500	(2.22)
B32-I-4	4"	(101)	80	(36.3)	800	(3.56)
B32-I-6	6"	(152)	108	(49.0)	1000	(4.45)
B32-I-8	8"	(203)	137	(62.1)	1200	(5.34)

Length Part No.	Wt./C		Lbs.	kg
	in.	mm		
B32-I-12	12"	(305)	202	(91.6)
B32-I-16	16"	(406)	262	(118.8)
B32-I-20	20"	(508)	316	(143.3)
B32-I-24	24"	(609)	376	(170.5)
B32-I-32	32"	(813)	496	(225.0)
B32-I-36	36"	(914)	556	(252.2)
B32-I-40	40"	(1016)	616	(279.4)
B32-I-48	48"	(1219)	736	(333.8)
B32-I-60	60"	(1524)	915	(415.0)
B32-I-72	72"	(1829)	1095	(496.7)
B32-I-84	84"	(2133)	1274	(577.9)
B32-I-96	96"	(2438)	1453	(659.0)
B32-I-108	108"	(2743)	1633	(740.7)
B32-I-120	120"	(3048)	1813	(822.3)
B32-I-144	144"	(3657)	2173	(985.6)
B32-I-168	168"	(4267)	2533	(1148.9)
B32-I-192	192"	(4877)	2893	(1312.2)
B32-I-216	216"	(5486)	3253	(1475.5)
B32-I-240	240"	(6096)	3613	(1638.8)

Reference page 212 for general fitting and standard finish specifications.

Continuous Concrete Inserts

B52I CONTINUOUS CONCRETE INSERT

- Design Load for B52-I-12 thru B52-I-240 is 1,500 lbs. (6.67 kN) per foot of concrete insert length with safety factor of 3 in 3000 psi concrete.
- Loads concentrated within the last 2 inches (50.8 mm) of concrete inserts 8" (203.2 mm) and longer should not exceed 750 lbs. (3.33kN).
- Concrete insert should be secured to the forms on 16" (406.4 mm) to 24" (609.6 mm) intervals.
- B52-I continuous concrete inserts are made from B52 channel. Use channel nuts designed for use in B52 channel.
- B52-I concrete inserts are supplied with styrofoam fillers. B3352 end caps are furnished with inserts through 8" (203.2 mm) long, and B220 end caps are furnished with inserts 12" (304.8 mm) and longer.
- Material: Plain Steel ASTM A1011 33,000 PSI min. yield or Pre-Galvanized Steel ASTM A653SS 33,000 PSI min. yield.
- Finish: Plain, DURA-GREEN™, Pre-Galv, HDG

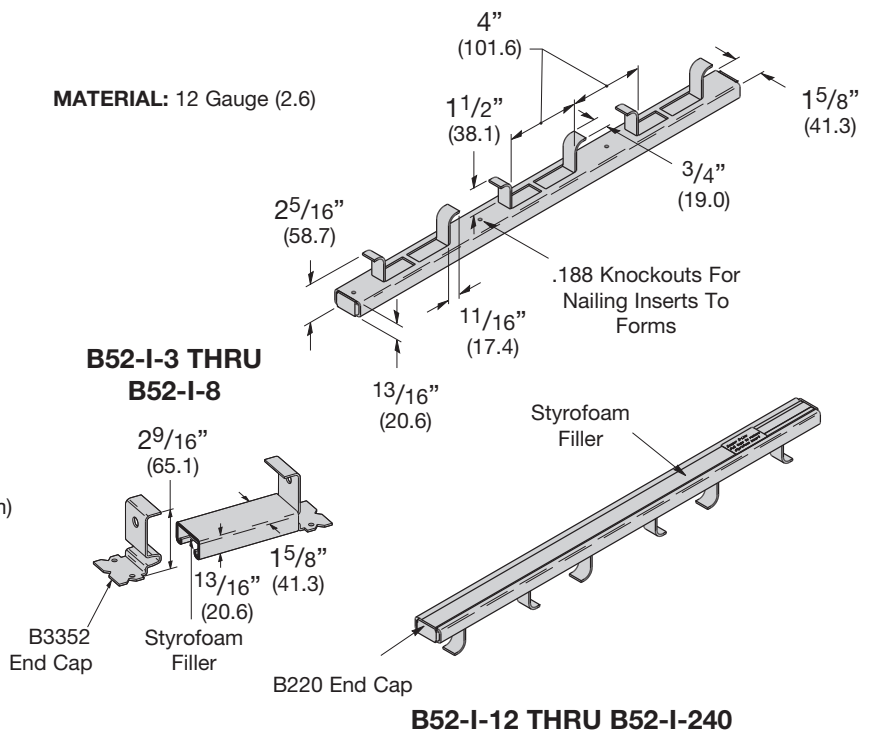

Part No.	Length		Wt./C		Design Load	
	in.	mm	Lbs.	kg	Lbs.	kN
B52-I-3	3"	(76)	53	(24.0)	400	(1.78)
B52-I-4	4"	(101)	63	(28.6)	500	(2.22)
B52-I-6	6"	(152)	85	(38.5)	750	(3.33)
B52-I-8	8"	(203)	106	(48.1)	1000	(4.45)

Part No.	Length		Wt./C	
	in.	mm	Lbs.	kg
B52-I-12	12"	(305)	157	(71.2)
B52-I-16	16"	(406)	202	(91.6)
B52-I-20	20"	(508)	237	(107.5)
B52-I-24	24"	(609)	282	(127.9)
B52-I-32	32"	(813)	373	(169.2)
B52-I-36	36"	(914)	419	(190.0)
B52-I-40	40"	(1016)	464	(210.4)
B52-I-48	48"	(1219)	556	(252.2)
B52-I-60	60"	(1524)	692	(313.9)
B52-I-72	72"	(1829)	829	(376.0)
B52-I-84	84"	(2133)	965	(437.7)
B52-I-96	96"	(2438)	1107	(502.1)
B52-I-108	108"	(2743)	1237	(561.1)
B52-I-120	120"	(3048)	1374	(623.2)
B52-I-144	144"	(3657)	1648	(747.5)
B52-I-168	168"	(4267)	1922	(871.8)
B52-I-192	192"	(4877)	2196	(996.1)
B52-I-216	216"	(5486)	2470	(1120.4)
B52-I-240	240"	(6096)	2744	(1244.6)

Reference page 212 for general fitting and standard finish specifications

B2500 SPOT INSERT

- Design Load 600 Lbs. (2.67 kN)
- Safety Factor of 5
- Order N2500 Nuts Separately
- Material: Steel ASTM A1011
33,000 PSI min. yield
- Standard finish: ZN
- Wt./C 46 Lbs. (20.8 kg)

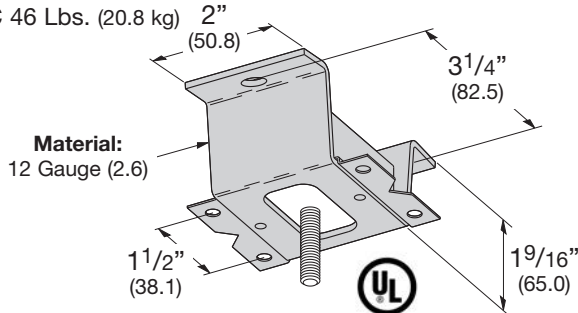

N2500 INSERT SQUARE NUT

- For use in B2500 Spot Insert
- Material: Steel ASTM A36
- Standard finish: ZN

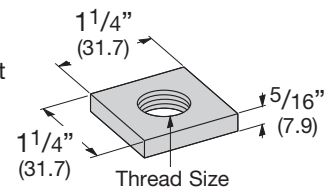

Part No.	Thread Size	Wt./C	
		Lbs.	kg
N2500-1/4	1/4"-20	13	(5.9)
N2500-5/16	5/16"-18	13	(5.9)
N2500-3/8	3/8"-16	12	(5.4)
N2500-1/2	1/2"-13	12	(5.4)
N2500-5/8	5/8"-11	11	(5.0)
N2500-3/4	3/4"-10	10	(4.5)
N2500-7/8	7/8"-9	9	(4.1)

B2503 HEAVY DUTY SPOT INSERT

- Designed for use where heavy loads are required in curtain wall applications
- Design Load is 5000 Lbs. (22.2 kN) with a Safety Factor of 3
- Loading based on two N225 channel nuts spaced 3" (76.2 mm) on center and a minimum of 2" (50.8 mm) from the end of the insert
- Styrofoam end caps prevent concrete seepage into the channel
- 12" (304.8 mm) long insert is anchored into the concrete at a depth of 5 1/2" (139.7 mm)
- Material: 12 Gauge (2.6 mm) thick steel
- Standard finish: ZN
- Wt./C 42 Lbs. (19.0 kg)

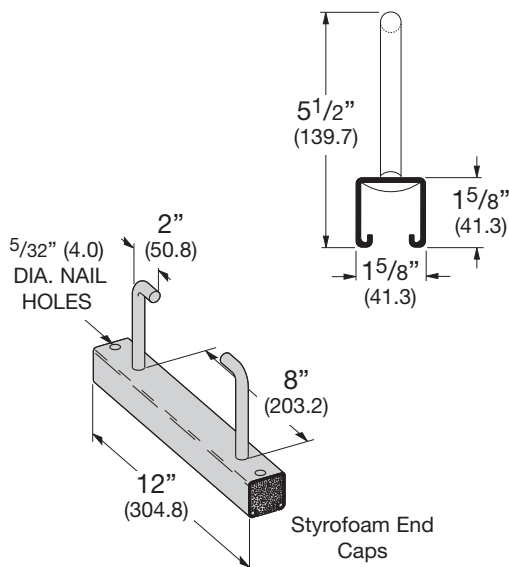

B2505 THRU B2508 SPOT INSERT

- Safety Factor of 5
- To support 10" (250) pipe use B2505 insert with 5/8"-11 Channel Nuts.
- To support up to and including 8" (200) pipes use B2506, B2507 and B2508 inserts with the desired Channel Nuts.
- Standard finish: ZN

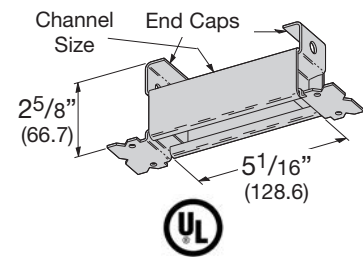

Part No.	Channel Style	End Cap Part No.	Design Load		Maximum Pipe Size	Wt./C	
			Lbs.	kN		Lbs.	kg
B2505	B22	B3322	1200	(5.34)	10" (250)	96	(43.5)
B2506	B32	B3332	1000	(4.45)	8" (200)	88	(39.9)
B2507	B42	B3342	1000	(4.45)	8" (200)	77	(34.9)
B2508	B52	B3352	1000	(4.45)	8" (200)	69	(31.3)

B2501 LIGHT DUTY SPOT INSERT

- Safety Factor of 2
- The concrete attachment problem solver for light duty applications.
- Fast and easy applications.
- No concrete leakage problems.
- One piece unitized construction.
- Color coded cap on thread for rod size identification and to prevent concrete seepage. (1/4"-Yellow, 3/8"-Red, 1/2"-Blue)

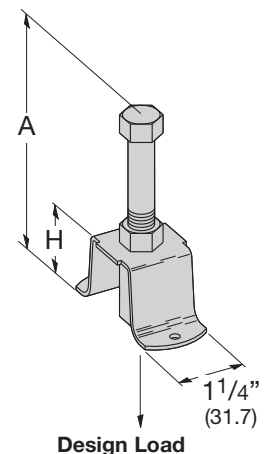

Part No. & Size	Height A		Height H		Design Load		Wt./C	
	Lbs.	kN	Lbs.	kN	Lbs.	kN	Lbs.	kN
B2501-1/4	2 7/16"	(61.9)	7/8"	(22.2)	250	(1.11)	16	(7.2)
B2501-3/8	3 1/16"	(77.8)	1 7/8"	(47.6)	610	(2.71)	22	(9.9)
B2501-1/2	4 1/8"	(104.8)	1 7/8"	(47.6)	880	(3.91)	26	(11.7)

Reference page 212 for general fitting and standard finish specifications.

Insert Accessories

B205, B206, B220 X TYPE END CAPS

- UL listed for raceway use only
- Material: 12 Gauge (2.6)
- Standard finish: ZN

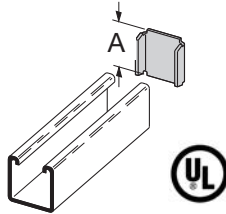

Part No.	Use With	A		Wt./C	
		Lbs.	kg	Lbs.	kg
B205	B22	1 ²¹ / ₃₂ "	(42.0)	10	(4.5)
B206	B32	1 ¹³ / ₃₂ "	(35.7)	8	(3.6)
B220	B52	2 ⁷ / ₃₂ "	(21.4)	4	(1.8)

B3322, B3332, B3342, B3352 Y TYPE END CAPS

- UL listed for raceway use only
- Material: 14 Gauge (1.9)
- Standard finish: ZN

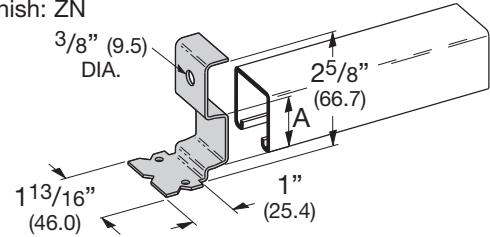

Part No.	Use With	A		Wt./C	
		Lbs.	kg	Lbs.	kg
B3322	B22	1.270	(32.2)	15	(6.8)
B3332	B32	1.000	(25.4)	15	(6.8)
B3342	B42	.645	(16.4)	15	(6.8)
B3352	B52	.460	(11.7)	15	(6.8)

B380 JOINT SPLICE PLATE

- Used at splice points to prevent concrete seepage in long continuous runs of concrete inserts.
- Material: 18 Gauge (1.2)
- Standard finish: GALV

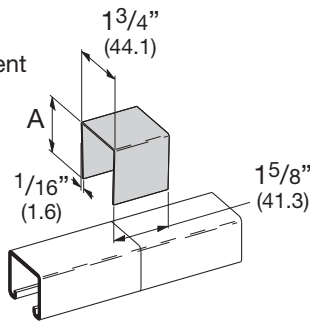

Part No.	Use With	A		Wt./C	
		Lbs.	kg	Lbs.	kg
B380-22	B22	1 ⁵ / ₈ "	(41.3)	11	(5.0)
B380-32	B32	1 ³ / ₈ "	(34.9)	10	(4.5)
B380-42	B42	1"	(25.4)	9	(4.1)
B380-52	B52	1 ³ / ₁₆ "	(20.6)	7	(3.2)

B22IFS-B52IFS STYROFOAM FILLER STRIP

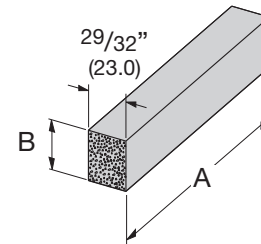

Part No.	Ft.	A		B	Wt./C	
		mm	Lbs.		kg	
B22-IFS	4'	(1219)	1 ⁷ / ₃₂ "	(309)	10	(4.5)
B32-IFS	4'	(1219)	1"	(254)	9	(4.1)
B52-IFS	4'	(1219)	2 ¹ / ₃₂ "	(167)	7	(3.2)

PIPE SLEEVE FASTENERS

- Allows for rigid attachment of pipe sleeves to wall and floor forms for concrete pouring.
- Accommodates Schedule 40, Schedule 80, or 5/16" (8) and smaller wall thickness.
- Simply installed with a hammer.

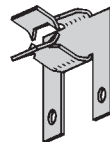

BD40

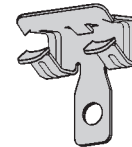

BE-5-8 & BE-9-12

Part No.	Sleeve Diameter	Wall Thickness
BD40	All Dia.	5/16" & under
BE-5-8	6"	Schedule 80 pipe
BE-9-12	9" - 14"	Schedule 80 pipe

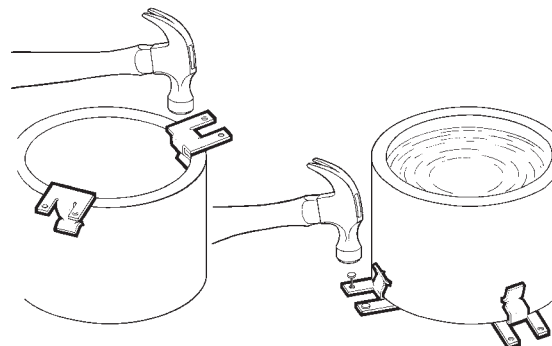

Concrete Inserts

Reference page 212 for general fitting and standard finish specifications

WEDGE ANCHOR

Catalog Number	Thread Size	Size		Thread Length		Drill/Hole Size		Load Cap. Tension*		Load Cap. Shear*	
		in.	mm	in.	mm	in.	mm	lbs.	kN	lbs.	kN
AWA-37-225	3/8"-16	3/8" x 2 1/4"	(9 x 57)	1 1/4"	(32)	3/8"	(9)	760	(3.38)	940	(4.18)
AWA-37-275	3/8"-16	3/8" x 2 3/4"	(9 x 70)	1 5/8"	(41)						
AWA-37-300	3/8"-16	3/8" x 3"	(9 x 76)	1 7/8"	(47)						
AWA-37-350	3/8"-16	3/8" x 3 1/2"	(9 x 89)	2 3/8"	(60)						
AWA-37-375	3/8"-16	3/8" x 3 3/4"	(9 x 95)	2 5/8"	(66)						
AWA-37-500	3/8"-16	3/8" x 5"	(9 x 127)	3 7/8"	(98)						
AWA-50-275	1/2"-13	1/2" x 2 3/4"	(13 x 70)	1 3/8"	(35)	1/2"	(13)	1390	(6.18)	1700	(7.56)
AWA-50-375	1/2"-13	1/2" x 3 3/4"	(13 x 95)	2 3/8"	(60)						
AWA-50-450	1/2"-13	1/2" x 4 1/2"	(13 x 114)	3 1/8"	(79)						
AWA-50-550	1/2"-13	1/2" x 5 1/2"	(13 x 140)	4 1/8"	(105)						
AWA-50-700	1/2"-13	1/2" x 7"	(13 x 178)	5 5/8"	(143)						

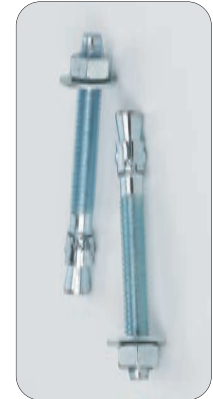

Note: Based on concrete compression strength of 4,000 psi using applied safety factor of 4.

HOLLOW BASE DROP-IN ANCHORS

Catalog Number	Rod Size	Overall Length		Sleeve Length		Drill/Hole Diameter		Load Cap. Tension*		Load Cap. Shear*	
		in.	mm	in.	mm	in.	mm	lbs.	kN	lbs.	kN
ADH-25	1/4"-20	7/8"	(22)	5/8"	(16)	3/8"	(9)	285	(1.27)	300	(1.33)
ADH-37	3/8"-16	1 5/16"	(33)	1 5/16"	(24)	5/8"	(16)	520	(2.31)	640	(2.84)
ADH-50	1/2"-13	1 3/4"	(44)	1 1/4"	(32)	3/4"	(19)	1005	(4.47)	1005	(44.70)
9323	1/4"	--	--	--	--	--	--	--	--	--	--
9343	3/8"	--	--	--	--	--	--	--	--	--	--
9353	1/2"	--	--	--	--	--	--	--	--	--	--



Note: Based on concrete compression strength of 4,000 psi using applied safety factor of 4.

RAPID ROD™ HANGERS FOR CONCRETE

Catalog Number	Rod Size	Shank Size & Length		Drill/Hole Size		Load Cap. Tension*		Load Cap. Shear*	
		in.	mm	in.	mm	Lbs.	kN	Lbs.	kN
ARC-25-125	1/4"-20	1/4" x 1 1/4"	(6 x 32)	1/4"	(6)	485	(2.16)	610	(2.71)
ARC-37-150	3/8"-16	1/4" x 1 1/2"	(6 x 38)	1/4"	(6)	650	(2.89)	660	(2.93)
ARC-50-275	1/2"-13	3/8" x 2 3/4"	(9 x 70)	1/4"	(6)	1510	(6.71)	1580	(7.03)



Note: Based on concrete compression strength of 4,000 psi using applied safety factor of 4.

RAPID ROD™ HANGERS FOR STEEL

Catalog Number	Rod Size	Shank Size & Length		Load Cap. Tension* In 12 Ga.		Load Cap. Tension* In 1/4"	
		in.	mm	Lbs.	kN	Lbs.	kN
ARS-25-100	1/4"-20	1/4" x 1"	(6 x 25)	390	(1.75)	1260	(5.60)
ARS-37-100HN	3/8"-16	1/4" x 1" *	(6 x 25)	512	(2.28)	1260	(5.60)
ARS-37-150	3/8"-16	1/4" x 1 1/2"	(6 x 38)	390	(1.75)	1260	(5.60)
ARS-37-150HN	3/8"-16	1/4" x 1 1/2"	(6 x 38)	512	(2.28)	1260	(5.60)
ARS-37-200	3/8"-16	1/4" x 2"	(6 x 51)	390	(1.75)	1260	(5.60)



Note: Loads shown for ASTM A36 beams and ASTM A572 steel purlins include a safety factor of 4. For UL and FM listings, steel rapid rod must be installed with a retaining nut.

Reference page 212 for general fitting and standard finish specifications.

Anchors

PLASTIC SCREW ANCHORS

- Kits contain 100 anchors, 100 screws, and 1 concrete drill bit



Catalog Number	Screw Size	Load Cap. Tension*		Load Cap. Shear*	
		Lbs.	kN	Lbs.	kN
APC-8K	#8 x 1"	110	(0.49)	70	(0.31)
APC-10K	#10 x 1"	140	(0.62)	90	(0.40)
APC-12K	#12 x 1"	140	(0.62)	90	(0.40)

Note: Based on concrete compression strength of 4,000 psi using applied safety factor of 4.

WOOD-KNOCKER™† ANCHORS



Catalog Number	Rod Size	Color	Insert Thread Length		Overall Length		Load Cap. Tension*		Load Cap. Shear*	
			in.	mm	in.	mm	lbs.	kN	lbs.	kN
ACPW-25	1/4"-20	Brown	3/8"	(9)	17/8"	(47)	930	(4.13)	370	(1.64)
ACPW-37	3/8"-16	Green	5/8"	(16)	17/8"	(47)	1200	(5.33)	1330	(5.91)
ACPW-50	1/2"-13	Yellow	11/16"	(17)	17/8"	(47)	1200	(5.33)	1840	(8.18)
ACPW-62	5/8"-11	Red	15/16"	(24)	17/8"	(47)	1160	(5.16)	2800	(12.45)
ACPW-75	3/4"-10	Purple	11/8"	(28)	17/8"	(47)	1160	(5.16)	2800	(12.45)

Notes: Based on normal weight concrete with minimum compression strength of 3,000 psi. Allowable load capacities are calculated using applied safety factor of 4. Minimum embedment is 2" (51mm).

† Wood-Knocker™ is a trademark of Powers® Fasteners

BANG-IT™† ANCHORS



Catalog Number	Rod Size	Color	Insert Thread Length		Upper Deck Tension Load*		Lower Deck Tension Load*		Upper Deck Shear Load*		Lower Deck Shear Load*	
			in.	mm	lbs.	kN	lbs.	kN	lbs.	kN	lbs.	kN
ACPD-25	1/4"-20	Brown	3/8"	(9)	1112	(4.94)	830	(3.69)	625	(2.78)	625	(2.78)
ACPD-37	3/8"-16	Green	5/8"	(16)	1435	(6.38)	830	(3.69)	837	(3.72)	837	(3.72)
ACPD-50	1/2"-13	Yellow	11/16"	(17)	1775	(7.89)	830	(3.69)	837	(3.72)	837	(3.72)
ACPD-62	5/8"-11	Red	15/16"	(24)	2200	(9.78)	990	(4.40)	837	(3.72)	837	(3.72)
ACPD-75	3/4"-10	Purple	11/8"	(28)	2200	(9.78)	990	(4.40)	837	(3.72)	837	(3.72)
ACPD-87	7/8"-9	Black	15/16"	(33)	2200	(9.78)	990	(4.40)	837	(3.72)	837	(3.72)

Notes: Based on normal weight concrete with minimum compression strength of 3,000 psi. Allowable load capacities are calculated using applied safety factor of 4. Minimum insert spacing of 12" (305mm), minimum end spacing of 12" (305mm). Minimum embedment is 2" (51mm). Length of sleeve is 33/8" (86mm).

† Bang-It™ is a trademark of Powers® Fasteners

Reference page 212 for general fitting and standard finish specifications

1/4" CONCRETE SCREWS

Catalog Number	Rod Size		Drill/Hole Size		Load Cap. Tension*		Load Cap. Shear*	
	in.	mm	in.	mm	lbs.	kN	lbs.	kN
ACS-125H	1/4" x 1 1/4"	(6 x 32)	3/16"	(5)	265	(1.18)	205	(0.91)
ACS-175H	1/4" x 1 3/4"	(6 x 44)	3/16"	(5)	265	(1.18)	205	(0.91)
ACS-225H	1/4" x 2 1/4"	(6 x 57)	3/16"	(5)	265	(1.18)	205	(0.91)
ACS-275H	1/4" x 2 3/4"	(6 x 70)	3/16"	(5)	265	(1.18)	205	(0.91)
ACS-325H	1/4" x 3 1/4"	(6 x 82)	3/16"	(5)	265	(1.18)	205	(0.91)

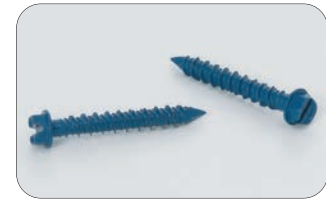

Note: Based on 1" (25mm) embedment with concrete compression strength of 4,000 psi using applied safety factor of 4. Consult factory for loading of other embedment depths.

SELF-TAPPING MACHINE SCREW ANCHOR

Catalog Number	Rod Size	Thread Depth		Drill/Hole Size		Load Cap. Tension*		Load Cap. Shear*	
		in.	mm	in.	mm	Lbs.	kN	Lbs.	kN
ATM-37	3/8"-16	1 1/16"	(17)	1/2"	(13)	540	(2.40)	825	(3.67)



Note: Based on concrete compression strength of 4,000 psi in uncracked concrete using applied safety factor of 4. Minimum concrete thickness 4" (101mm) with minimum embedment of 1 5/8" (41mm)

WALL SCREWS

Catalog Number	Head Type	Thread Depth		Minimum Embedment		Load Cap. Tension*		Load Cap. Shear*	
		in.	mm	in.	mm	Lbs.	kN	Lbs.	kN
AWS-CH	Combo	3/16" x 1 1/4"	(5 x 32)	3/4"	(19)	90	(0.40)	260	(1.15)
AWS-OH	Oval	3/16" x 1 1/4"	(5 x 32)	3/4"	(19)	90	(0.40)	260	(1.15)
AWS-PH	Pan	3/16" x 1 1/4"	(5 x 32)	3/4"	(19)	90	(0.40)	260	(1.15)



Note: Based on concrete compression strength of 4,000 psi. Allowable load capacities are calculated using an applied safety factor of 4.

SLEEVE TYPE EXPANSION ANCHORS

Catalog Number	Anchor Size & Length		Thread Length		Drill/Hole Diameter		Minimum Embedment		Load Cap. Tension*		Load Cap. Shear*	
	in.	mm	in.	mm	in.	mm	in.	mm	lbs.	kN	lbs.	kN
ASA-37-187HN	3/8" x 1 7/8"	(9 x 47)	1 5/8"	(41)	3/8"	(9)	1 5/8"	(41)	670	(2.98)	610	(2.71)
ASA-37-300HN	3/8" x 3"	(9 x 76)	1 5/8"	(41)	3/8"	(9)	1 5/8"	(41)	670	(2.98)	610	(2.71)
ASA-37-400HN	3/8" x 4"	(9 x 101)	1 5/8"	(41)	3/8"	(9)	1 5/8"	(41)	670	(2.98)	610	(2.71)
ASA-50-225HN	1/2" x 2 1/4"	(13 x 57)	2 1/4"	(57)	1/2"	(13)	2 1/4"	(57)	1255	(5.58)	1055	(4.69)
ASA-50-300HN	1/2" x 3"	(13 x 76)	2 1/4"	(57)	1/2"	(13)	2 1/4"	(57)	1255	(5.58)	1055	(4.69)
ASA-50-400HN	1/2" x 4"	(13 x 101)	2 1/4"	(57)	1/2"	(13)	2 1/4"	(57)	1255	(5.58)	1055	(4.69)
ASA-50-525HN	1/2" x 5 1/4"	(13 x 133)	2 1/4"	(57)	1/2"	(13)	2 1/4"	(57)	1255	(5.58)	1055	(4.69)
ASA-50-600HN	1/2" x 6"	(13 x 152)	2 1/4"	(57)	1/2"	(13)	2 1/4"	(57)	1255	(5.58)	1055	(4.69)



Note: Based on concrete compression strength of 4,000 psi using applied safety factor of 4.

Reference page 212 for general fitting and standard finish specifications.

Slotted Angle

Our Slotted Angle is an all-purpose framing system, roll formed from high strength steel strips. It is designed to be used as economical shelving, racks or electrical and mechanical supports. The unique pattern of horizontal and vertical slots permits full flexibility. Three basic sizes are available for light, medium, and heavy duty applications.

Materials & Finishes*

Finish Code	Finish	Specification
PLN	Plain	ASTM A1011 33,000 PSI min. yield
ZN	Electro-Plated Zinc	ASTM B633 SC3
GRN	DURA-GREEN™	
GALV	Pre-Galvanized	ASTM A653 33,000 PSI min. yield

*Unless otherwise noted.

Lengths

Standard lengths are 10' (3.05 m) and 12' (3.66 m). Slotted Angle is shipped in ten piece bundles complete with 75 pieces of $\frac{3}{8}$ " x $\frac{3}{4}$ " (19mm) hex head cap screws and $\frac{3}{8}$ " hex nuts.

Metric

Metric dimensions are shown in parentheses. Unless noted, all metric dimensions are in millimeters.

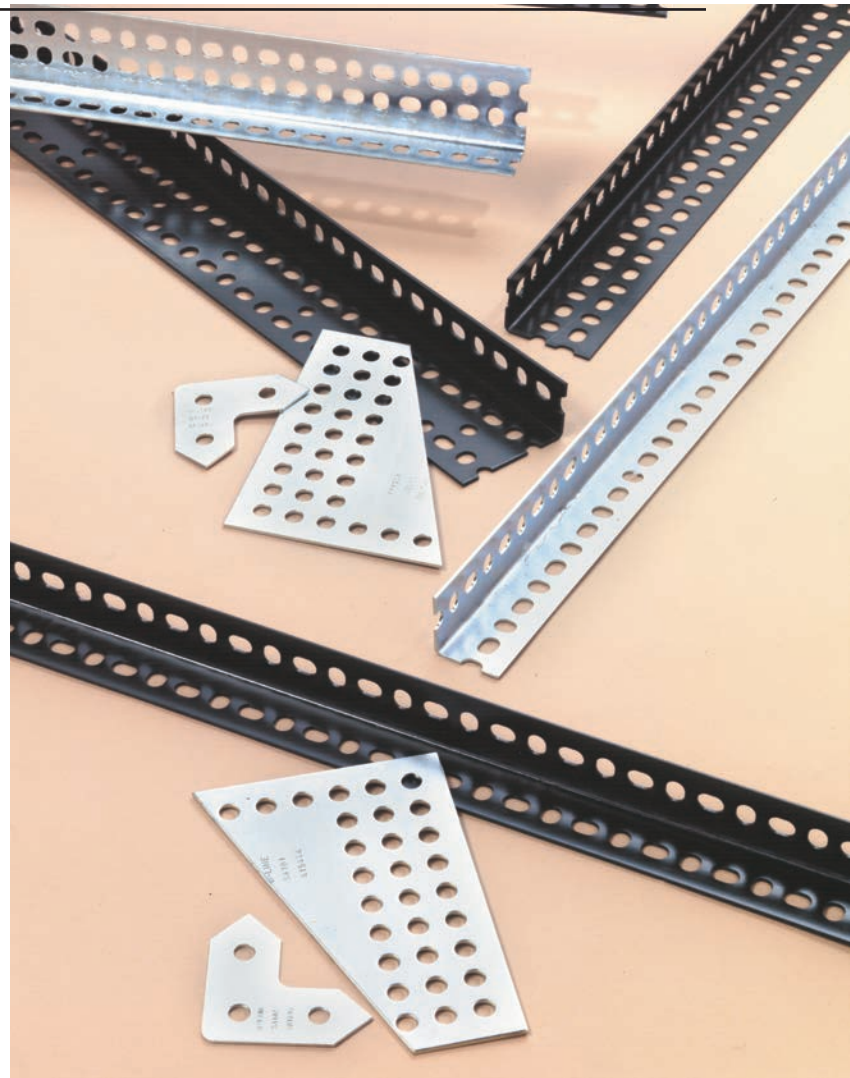

Slotted Angle Sizes

SA158

- 14 Gauge (1.9)
- 15/8" x 15/8"
- Standard finishes: ZN, GRN
- Wt./Ft. .66 Lbs. (.98 kg/m)

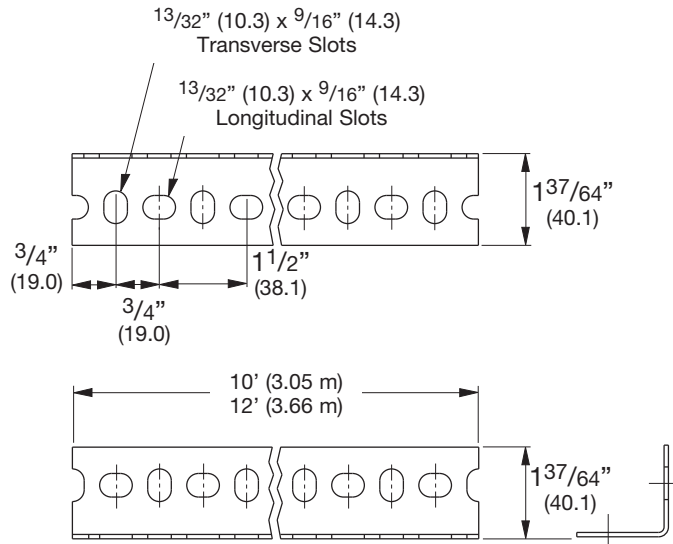
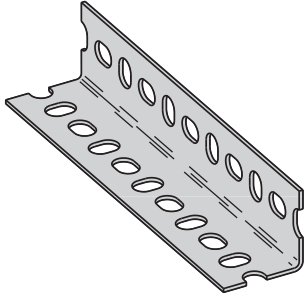

SA276

- 14 Gauge (1.9)
- 15/8" x 23/8"
- Standard finishes: ZN, GRN
- Wt./Ft. .78 Lbs. (1.17 kg/m)

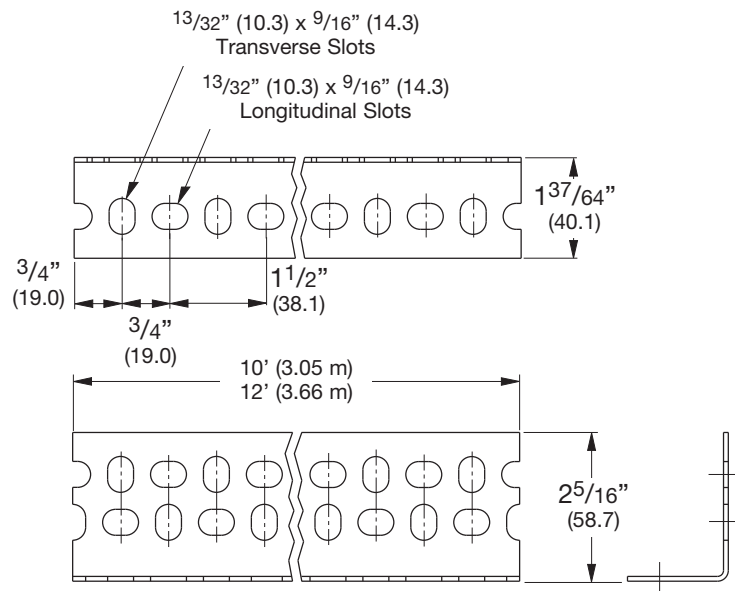
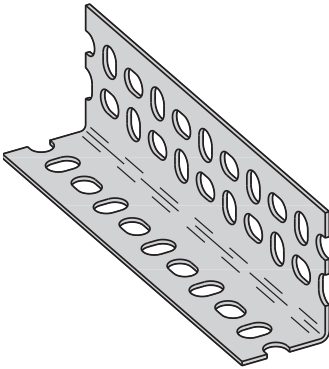

SA318

- 12 Gauge (2.6)
- 15/8" x 3 1/8"
- Standard finishes: ZN, GRN
- Wt./Ft. 1.32 Lbs. (1.96 kg/m)

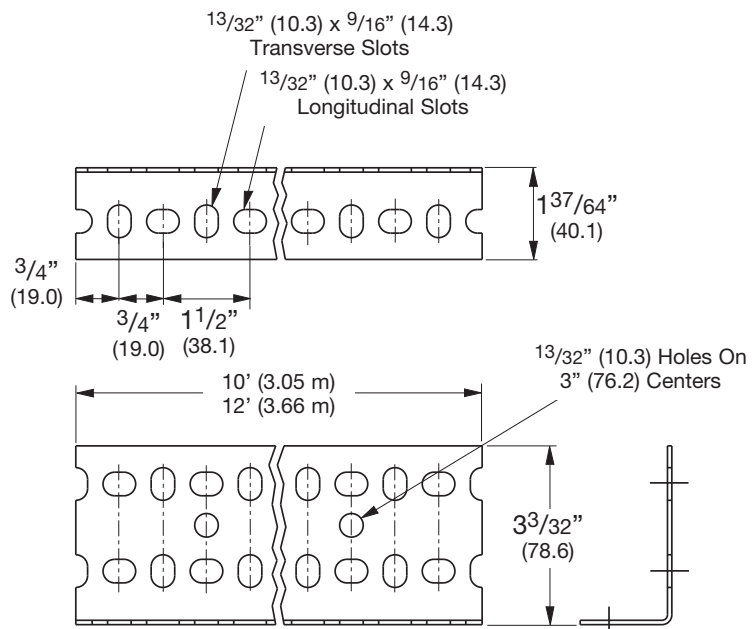
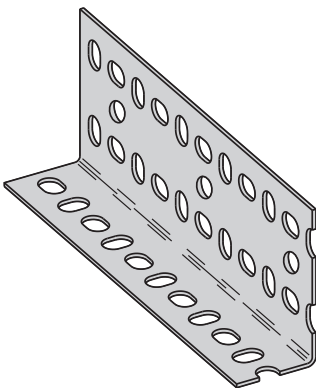

Reference page 222 for general fitting and standard finish specifications.

Slotted Angle Beam Loading & Combinations

BEAM SECTIONS

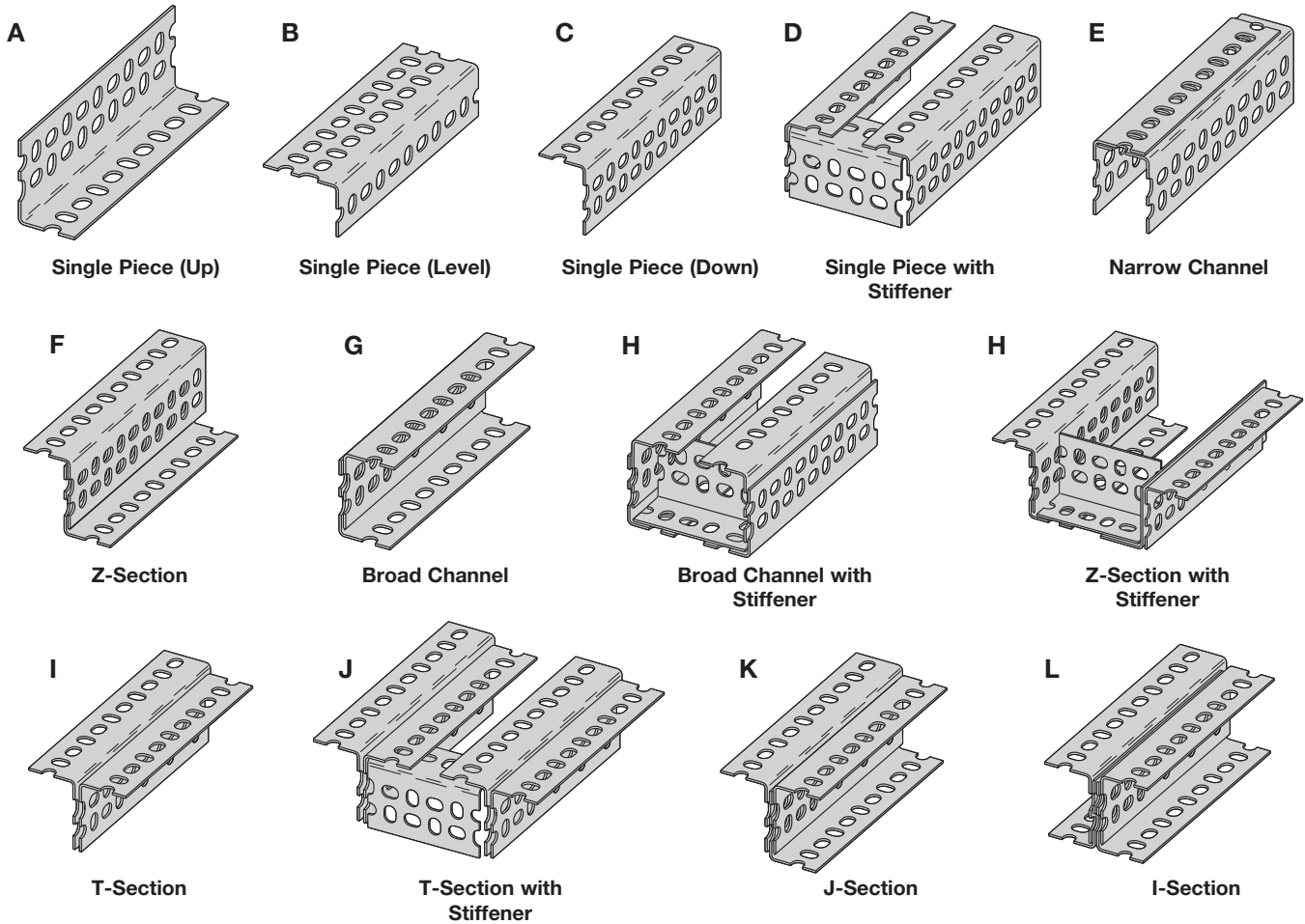

For greater strength required in some applications, Slotted Angle may be fastened together to create combination shapes. A number of these combinations are illustrated above. Refer to the following table for load capacities of these combinations.

Beam Sections illustrated are single sections, except J, N, and P.

BEAM LOADING

SA158-1⁵/₈" (41.3) x 1⁵/₈" (41.3) x 14 Gauge (1.9)

	Beam Span													
	24" (609 mm)		36" (914 mm)		48" (1219 mm)		60" (1524 mm)		72" (1829 mm)		84" (2133 mm)		96" (2438 mm)	
	Lbs.	kN	Lbs.	kN	Lbs.	kN	Lbs.	kN	Lbs.	kN	Lbs.	kN	Lbs.	kN
A	825	(3.67)	525	(2.33)	340	(1.51)	230	(1.02)	180	(0.80)	-	-	-	-
B	1100	(4.89)	800	(3.56)	540	(2.40)	370	(1.64)	250	(1.11)	-	-	-	-
C	1100	(4.89)	800	(3.56)	540	(2.40)	370	(1.64)	250	(1.11)	-	-	-	-
D	1300	(5.78)	900	(4.00)	625	(2.78)	450	(2.00)	330	(1.47)	275	(1.22)	200	(0.89)
G	1900	(8.45)	1360	(6.05)	1050	(4.67)	825	(3.67)	660	(2.93)	530	(2.36)	400	(1.78)
H	2300	(10.23)	1850	(8.23)	1450	(6.45)	1100	(4.89)	950	(4.22)	800	(3.56)	700	(3.11)
I	2200	(9.78)	1650	(7.34)	1225	(5.45)	930	(4.14)	700	(3.11)	550	(2.44)	450	(2.00)

Based on simple beam condition with uniform loads on parallel beams. To determine concentrated load capacity at mid-span, multiply uniform load by 0.5.

Reference page 222 for general fitting and standard finish specifications.

Slotted Angle Beam Loading

BEAM LOADING

SA276-1⁵/₈" (41.3) x 2³/₈" (60.3) x 14 Gauge (1.9)

	Beam Span																	
	24" (609 mm)		36" (914 mm)		48" (1219 mm)		60" (1524 mm)		72" (1829 mm)		84" (2133 mm)		96" (2438 mm)		108" (2743 mm)		120" (3048 mm)	
	Lbs.	kN	Lbs.	kN	Lbs.	kN	Lbs.	kN	Lbs.	kN	Lbs.	kN	Lbs.	kN	Lbs.	kN	Lbs.	kN
A	-	-	680	(3.02)	450	(2.00)	340	(1.51)	-	-	-	-	-	-	-	-	-	-
B	-	-	830	(3.69)	550	(2.44)	360	(1.60)	210	(0.93)	150	(0.67)	-	-	-	-	-	-
C	-	-	1540	(6.85)	1060	(4.71)	800	(3.56)	610	(2.71)	480	(2.13)	340	(1.51)	250	(1.11)	-	-
D	-	-	1880	(8.36)	1280	(5.69)	970	(4.31)	820	(3.65)	650	(2.89)	550	(2.44)	420	(1.87)	340	(1.51)
E	-	-	2110	(9.38)	1730	(7.69)	1460	(5.77)	1250	(5.56)	1090	(4.85)	920	(4.09)	820	(3.65)	680	(3.02)
F	4290	(19.08)	2510	(11.16)	1790	(7.96)	1330	(5.91)	980	(4.36)	710	(3.16)	550	(2.44)	420	(1.87)	320	(1.42)
G	4320	(19.21)	3000	(13.34)	2140	(9.52)	1600	(7.12)	1290	(5.74)	1040	(4.62)	820	(3.65)	640	(2.85)	490	(2.18)
H	-	-	3480	(15.48)	2430	(10.81)	1890	(8.41)	1620	(7.20)	1430	(6.36)	1270	(5.65)	1160	(5.16)	1030	(4.58)
I	5780	(25.71)	3640	(16.19)	2820	(12.54)	2200	(9.78)	1700	(7.56)	1350	(6.00)	1060	(4.71)	850	(3.78)	680	(3.02)
J	-	-	3660	(16.28)	2840	(12.63)	2230	(9.92)	1720	(7.65)	1360	(6.05)	1090	(4.85)	874	(3.89)	700	(3.11)
K	-	-	4910	(21.84)	3830	(17.03)	3000	(13.34)	2550	(11.34)	2190	(9.74)	1880	(8.36)	1640	(7.29)	1430	(6.36)
L	-	-	6360	(28.29)	4590	(20.42)	3470	(15.43)	2910	(12.94)	2550	(11.34)	2240	(9.96)	2010	(8.94)	1840	(8.18)

Based on simple beam condition with uniform loads on parallel beams. To determine concentrated load capacity at mid-span, multiply uniform load by 0.5.

BEAM LOADING

SA318-1⁵/₈" (41.3) x 3¹/₈" (79.4) x 12 Gauge (2.6)

	Beam Span																	
	24" (609 mm)		36" (914 mm)		48" (1219 mm)		60" (1524 mm)		72" (1829 mm)		84" (2133 mm)		96" (2438 mm)		108" (2743 mm)		120" (3048 mm)	
	Lbs.	kN	Lbs.	kN	Lbs.	kN	Lbs.	kN	Lbs.	kN	Lbs.	kN	Lbs.	kN	Lbs.	kN	Lbs.	kN
A	-	-	1140	(5.07)	850	(3.78)	690	(3.07)	-	-	-	-	-	-	-	-	-	-
B	-	-	1250	(5.56)	850	(3.78)	600	(2.67)	400	(1.78)	-	-	-	-	-	-	-	-
C	4800	(21.35)	2750	(12.23)	1800	(8.01)	1280	(5.69)	1000	(4.45)	790	(3.51)	610	(2.71)	-	-	-	-
D	-	-	3900	(17.35)	2690	(11.96)	2050	(9.12)	1700	(7.56)	1480	(6.58)	1280	(5.69)	1100	(4.89)	960	(4.27)
E	-	-	4160	(18.50)	3560	(15.83)	3130	(13.92)	2750	(12.23)	2400	(10.67)	2170	(9.65)	1950	(8.67)	1780	(7.92)
F	8180	(36.38)	5000	(22.24)	3650	(16.23)	2750	(12.23)	2200	(9.78)	1750	(7.78)	1350	(6.00)	1020	(4.54)	700	(3.11)
G	10600	(47.15)	6050	(26.91)	4440	(19.75)	3330	(14.81)	2670	(11.88)	2120	(9.43)	1660	(7.38)	1210	(5.38)	1000	(4.45)
H	-	-	6100	(27.13)	4620	(20.55)	3670	(16.32)	3110	(13.83)	2680	(11.92)	2380	(10.59)	2100	(9.34)	1950	(8.67)
I	13700	(60.94)	7800	(34.69)	5900	(26.24)	4600	(20.46)	3800	(16.90)	3190	(14.19)	2630	(11.70)	2170	(9.65)	1810	(8.05)
J	-	-	7900	(35.14)	6300	(28.02)	5050	(22.46)	4070	(18.10)	3240	(14.41)	2630	(11.70)	2170	(9.65)	1810	(8.05)
K	-	-	10050	(44.70)	8000	(35.58)	6320	(28.11)	5350	(23.80)	4650	(20.68)	4040	(17.97)	3520	(15.66)	3120	(13.88)
L	-	-	12700	(56.49)	9550	(42.48)	7540	(33.54)	6540	(29.09)	5730	(25.49)	5030	(22.37)	4520	(20.10)	4000	(17.79)

Based on simple beam condition with uniform loads on parallel beams. To determine concentrated load capacity at mid-span, multiply uniform load by 0.5.

Reference page 222 for general fitting and standard finish specifications.

Slotted Angle Beam Loading & Combinations

COLUMN SECTIONS

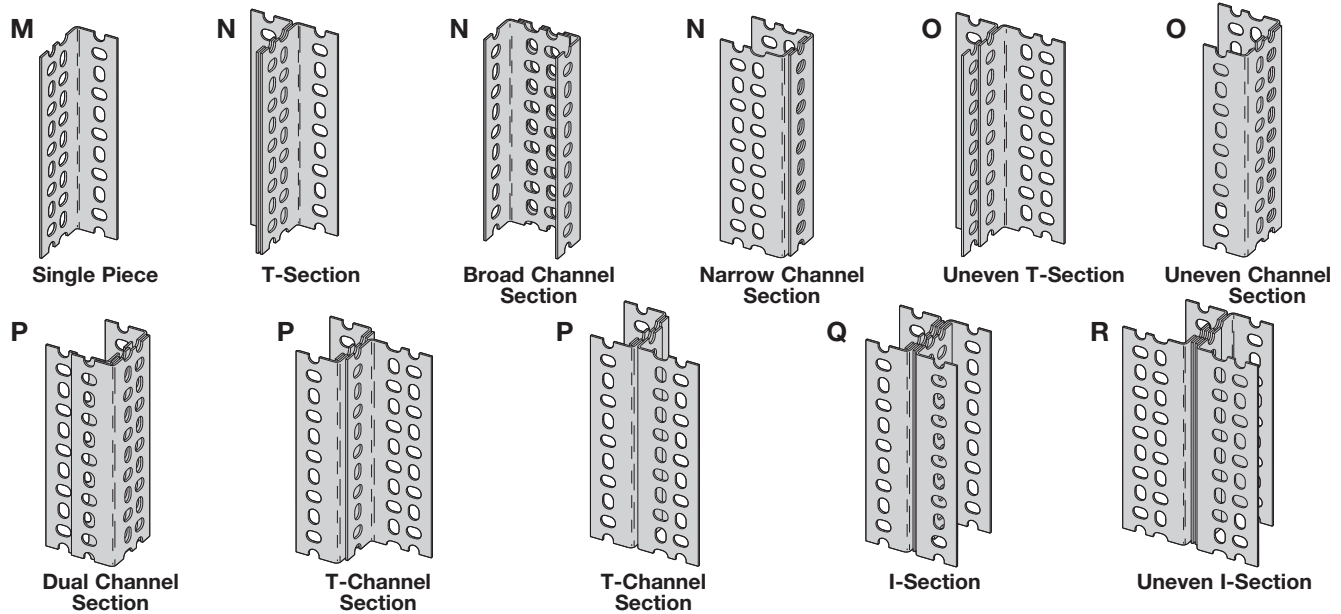

For greater strength required in some applications, Slotted Angle may be fastened together to create combination shapes. A number of these combinations are illustrated above. Refer to the following table for load capacities of these combinations.

COLUMN LOADING - SA158-1⁵/₈" (41.3) x 1⁵/₈" (41.3) x 14 Gauge (1.9)

	Column Height							
	36" (914 mm)		48" (1219 mm)		60" (1524 mm)		72" (1829 mm)	
	Lbs.	kN	Lbs.	kN	Lbs.	kN	Lbs.	kN
M	1450	(6.45)	1150	(5.11)	950	(4.22)	750	(3.33)
N	3850	(17.12)	3500	(15.57)	3000	(13.34)	2500	(11.12)

Column Loads assume no lateral support.

COLUMN LOADING - SA276-1⁵/₈" (41.3) x 2³/₈" (60.3) x 14 Gauge (1.9)

	Column Height															
	36" (914 mm)		48" (1219 mm)		60" (1524 mm)		72" (1829 mm)		84" (2133 mm)		96" (2438 mm)		108" (2743 mm)		120" (3048 mm)	
	Lbs.	kN	Lbs.	kN	Lbs.	kN	Lbs.	kN	Lbs.	kN	Lbs.	kN	Lbs.	kN	Lbs.	kN
M	2280	(10.14)	1970	(8.76)	1520	(6.76)	1070	(4.760)	660	(2.93)	-	-	-	-	-	-
N	4760	(21.17)	4490	(19.97)	3995	(17.77)	3140	(13.97)	2340	(10.41)	1750	(7.78)	-	-	-	-
O	4940	(21.97)	4680	(20.82)	4310	(19.17)	3870	(17.21)	3665	(16.30)	2700	(12.01)	2060	(9.16)	1610	(7.16)
P	7270	(32.34)	6920	(30.78)	6370	(28.33)	5840	(25.98)	4930	(21.93)	3850	(17.12)	2870	(12.76)	2060	(9.16)
Q	9520	(42.35)	8970	(39.90)	7990	(35.54)	6280	(27.93)	4660	(20.73)	3500	(15.57)	-	-	-	-
R	9865	(43.88)	9330	(41.50)	8620	(38.34)	7715	(34.32)	6740	(29.98)	5365	(23.86)	4115	(18.30)	3210	(14.28)

Column Loads assume no lateral support.

COLUMN LOADING - SA318-1⁵/₈" (41.3) x 3¹/₈" (79.4) x 12 Gauge (2.6)

	Column Height															
	36" (914 mm)		48" (1219 mm)		60" (1524 mm)		72" (1829 mm)		84" (2133 mm)		96" (2438 mm)		108" (2743 mm)		120" (3048 mm)	
	Lbs.	kN	Lbs.	kN	Lbs.	kN	Lbs.	kN	Lbs.	kN	Lbs.	kN	Lbs.	kN	Lbs.	kN
M	3470	(15.43)	2870	(12.76)	1970	(8.76)	1280	(5.69)	-	-	-	-	-	-	-	-
N	7970	(35.45)	7360	(32.74)	6570	(29.22)	5270	(23.44)	3670	(16.32)	2580	(11.47)	-	-	-	-
O	8770	(39.01)	8580	(38.16)	8180	(36.38)	7690	(34.21)	6970	(31.00)	6260	(27.84)	5460	(24.29)	4460	(19.84)
P	12560	(55.87)	11970	(53.24)	11360	(50.53)	10480	(46.62)	9470	(42.12)	8370	(37.23)	6880	(30.60)	5370	(23.89)
Q	15940	(70.90)	14750	(65.61)	13160	(58.54)	10560	(46.97)	7370	(32.78)	5170	(23.00)	-	-	-	-
R	17550	(78.06)	17150	(76.29)	16360	(72.77)	15360	(68.32)	13970	(62.14)	12570	(55.91)	10970	(48.80)	8960	(39.85)

Column Loads assume no lateral support.

Reference page 222 for general fitting and standard finish specifications.

Slotted Angle Kits & Fittings

AHHK-1/4 & AHHK-3/8 AIR HANDLER HANGING KIT

- Standard finishes: ZN
- Load Capacity Per Kit: 400 Lbs. (181.4 kg)

- ⑧ Hanging rods come in 72" lengths. Rods can be field cut for proper height requirement.

Item #	Description	Quantity	
		AHHK 1/4	AHHK 3/8
①	Rod Hanger Fitting	4	4
②	Lag Screw	4	4
③	Hex Head Cap Screw	4	4
④	Flat Washer (For HHCS)	4	4
⑤	Hex Nuts (For HHCS)	4	4
⑥	Hex Nuts (For Hanging Rods)	16	16
⑦	Flat Washer (See Note 1)	16	-
⑧	Hanging Rods (72" Long)	4	4
⑨	SA158 (36" Long)	2	2

Note 1: Flat washers are required for 1/4"-20 hanging rods only.

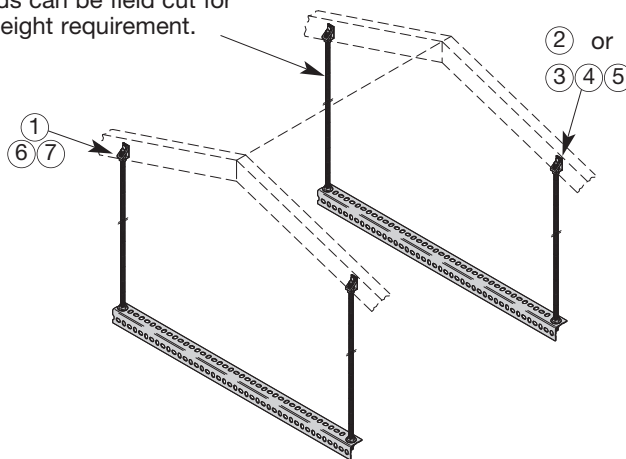

SA101 CONNECTION PLATE

- Standard finishes: ZN, GRN
- Wt./C 67 Lbs. (30.4 kg)

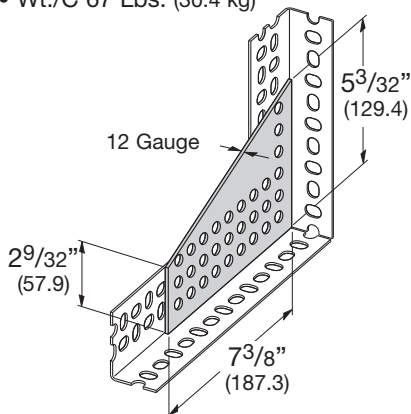

SA102 ANGLE BRACE

- Standard finishes: ZN, GRN
- Wt./C 15 Lbs. (6.8 kg)

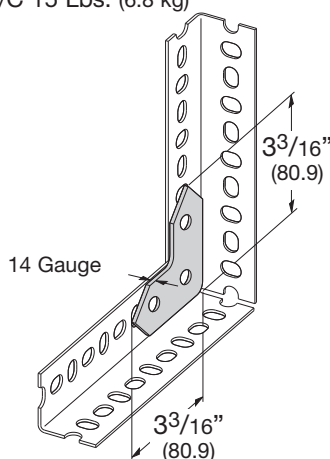

SA154 RIGID CASTER

- Safety Factor of 1.5
- 300 Lbs. (136.1 kg) maximum load capacity
- Caster material: Phenolic
- Standard finishes: ZN, GRN
- Wt./Ea. 2.0 Lbs. (.91 kg)

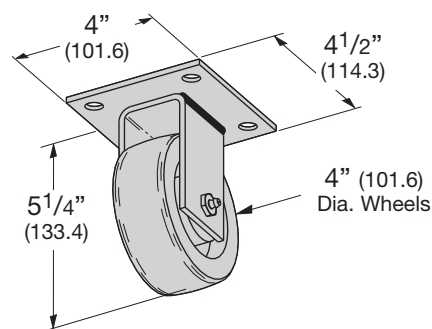

SA155 SWIVEL CASTER

- Safety Factor of 1.5
- 300 Lbs. (136.1 kg) maximum load capacity
- Caster material: Phenolic
- Standard finishes: ZN, GRN
- Wt./Ea. 2.2 Lbs. (1.0 kg)

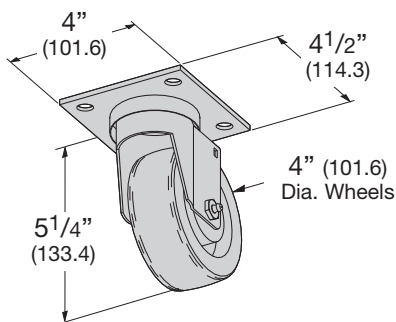

SA110 SLOTTED ANGLE CUTTER

- Standard finishes:
- Wt./Ea. 16 Lbs. (7.26 kg)

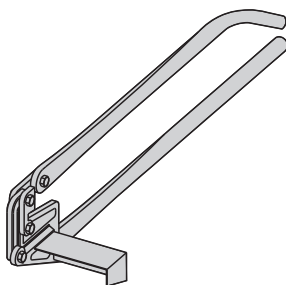

SA131 SLOTTED STRAP

- Hole pattern is identical to the hole pattern in slotted angles
- Standard length: 10' (3.05 m)
- Standard finishes: Pre-Galv. (GALV)
- Material thickness: 14 gauge (1.9)

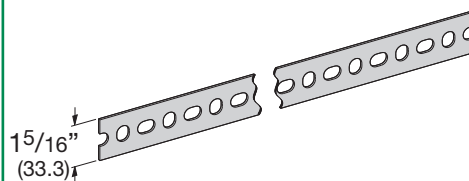

CLEATS: To reinforce load-bearing joints, cleats can be field made by cutting 2 1/4" (57.1) long segments from the widest slotted angle available. Use SA276 for light duty cleats and SA318 for heavy duty cleats.

SPLICE PLATES: To assemble two pieces of slotted angle using a butt joint requires a 6" (152.4) splice plate for reinforcement.

Reference page 222 for general fitting and standard finish specifications.

Reference Data

METRIC CONVERSION CHART

To Convert From	To	Multiply By	To Convert From	To	Multiply By
Angle			Length		
degree	radian (rad)	0.01745329	foot (ft)	meter (m)	0.3048
radian (rad)	degree	57.29578	inch (in)	meter (m)	0.0254
Area			mil	meter (m)	0.0000254
			inch (in)	micrometer (µm)	25400.00
			meter (m)	foot (ft)	3.280840
			meter (m)	inch (in)	39.37008
			meter (m)	mil	39370.08
			micrometer (µm)	inch (in)	0.00003937008
			Temperature		
foot³	cubic meter (m³)	0.02831685			
inch³	cubic meter (m³)	0.00001638706			
cubic centimeter (cm³)	cubic inch (in³)	0.06102374			
cubic meter (m³)	foot³	35.31466			
degree Fahrenheit	degree Celsius	$t^{\circ C} = (t^{\circ F} - 32) / 1.8$	cubic meter (m³)	inch³	61023.76
degree Celsius	degree Fahrenheit	$t^{\circ F} = 1.8t^{\circ C} + 32$	gallon (U.S. liquid)	cubic meter (m³)	0.003785412
Force			Section Properties		
pounds-force (lbf)	newtons (N)	4.448222	section modulus S (in³)	S (m³)	0.00001638706
			moment of inertia I (in⁴)	I (m⁴)	0.0000004162314
			modulus of elasticity E (psi)	E (Pa)	6894.757
			section modulus S (m³)	S (in³)	61023.74
			moment of inertia I (m⁴)	I (in⁴)	2402510.0
			modulus of elasticity E (Pa)	E (psi)	0.0001450377

To Convert From	To	Multiply By
Bending Moment or Torque		
lbf • ft	newton meter (N•m)	1.355818
lbf • in	newton meter (N•m)	0.1129848
N•m	lbf • ft	0.7375621
N•m	lbf • in	8.850748
Mass		
ounce (avoirdupois)	kilogram (kg)	0.02834952
pound (avoirdupois)	kilogram (kg)	0.4535924
ton (short, 2000 lb)	kilogram (kg)	907.1847
ton (long, 2240 lb)	kilogram (kg)	1016.047
kilogram (kg)	ounce (avoirdupois)	35.27396
kilogram (kg)	pound (avoirdupois)	2.204622
kilogram (kg)	ton (short, 2000 lb)	0.001102311
kilogram (kg)	ton (long, 2240 lb)	0.0009842064
Mass Per Unit Length		
lb/ft	kilogram per meter (kg/m)	1.488164
lb/in	kilogram per meter (kg/m)	17.85797
kg/m	lb/ft	0.6719689
kg/m	lb/in	0.5599741
Mass Per Unit Volume		
lb/ft³	kilogram per cubic meter (kg/m³)	16.01846
lb/in³	kilogram per cubic meter (kg/m³)	27679.9
kg/m³	lb/ft³	0.06242797
kg/m³	lb/in³	0.0000361273
lbs/ft³	lbs/in³	1728.0
Mass Per Unit Area		
lb/ft²	kilogram per square meter (kg/m²)	4.882428
kg/m²	pound per square foot (lb/ft²)	0.2048161
Pressure or Stress		
lbf/in² (psi)	pascal (Pa)	6894.757
kip/in² (ksi)	pascal (Pa)	6894757.0
lbf/in² (psi)	megapascals (MPa)	0.006894757
pascal (Pa)	pound-force per square inch (psi)	0.0001450377
pascal (Pa)	kip per square inch (ksi)	0.0000001450377
megapascals (MPa)	lbf/in² (psi)	145.0377

Abbreviations
Defl. = Deflection
S.F. = Safety Factor
Ft. = Feet
Pre-galv. = Pre-galvanized Steel
K Factor = Deflection ÷ load in Lbs./Ft.
o.c. = On Center
PVC = Poly Vinyl Chloride
In. = Inch
psi = Pounds per Square Inch
wt./c = Weight per 100 pieces

Metric Symbols
m = meter
cm = centimeter
mm = millimeter
µm = micrometer
kg = kilogram
N = newton
kN = kilonewton
Pa = pascal
MPa = megapascal

DESIGN LOAD DATA (For typical channel-fitting connections when USED IN PAIRS).

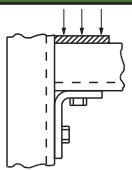
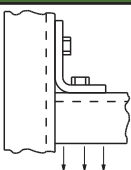
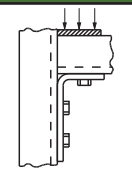
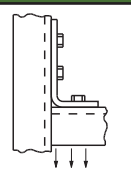
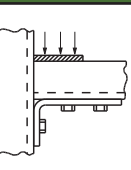
Channel Thickness		90° Fittings									
											
Lbs.	kN	Lbs.	kN	Lbs.	kN	Lbs.	kN	Lbs.	kN	Lbs.	kN
12 ga. (2.6)	1500 (6.67)	1000 (4.45)	2000 (8.90)	1500 (6.67)	1500 (6.67)	1000 (4.45)	1000 (4.45)	1500 (6.67)	1500 (6.67)	1000 (4.45)	1000 (4.45)
14 ga. (1.9)	1000 (4.45)	650 (2.89)	1500 (6.67)	1150 (5.12)	1000 (4.45)	650 (2.89)	650 (2.89)	1000 (4.45)	1000 (4.45)	650 (2.89)	650 (2.89)
16 ga. (1.5)	750 (3.34)	500 (2.22)	900 (4.00)	650 (2.89)	1000 (4.45)	500 (2.22)	500 (2.22)	1000 (4.45)	1000 (4.45)	500 (2.22)	500 (2.22)

Design load data includes a safety factor of 2.5 (safety factor = ratio of ultimate load to design load).

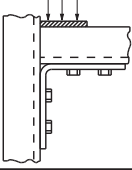
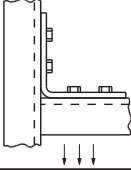
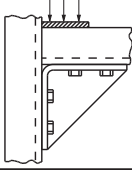
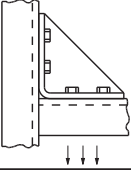
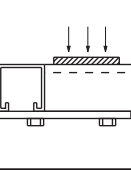
Channel Thickness		90° Fittings						Flat Fittings			
											
Lbs.	kN	Lbs.	kN	Lbs.	kN	Lbs.	kN	Lbs.	kN	Lbs.	kN
12 ga. (2.6)	2500 (11.12)	2000 (8.90)	3000 (13.34)	2500 (11.12)	1000 (4.45)	1000 (4.45)	1000 (4.45)	1000 (4.45)	1000 (4.45)	1000 (4.45)	1000 (4.45)
14 ga. (1.9)	2000 (8.90)	1650 (7.34)	2000 (8.90)	1650 (7.34)	500 (3.56)	800 (3.56)	500 (3.56)	800 (3.56)	500 (3.56)	800 (3.56)	800 (3.56)
16 ga. (1.5)	1500 (6.67)	1250 (5.56)	1500 (6.67)	1250 (5.56)	600 (2.67)	600 (2.67)	600 (2.67)	600 (2.67)	600 (2.67)	600 (2.67)	600 (2.67)

Reference Data

General Notes for Strut-Type Channel Raceway

UL Category RIUU - B-Line, Inc., Highland, IL 62249 December 11, 1998 (C)
 FLUORESCENT AND INCANDESCENT LIGHTING



Suitable for not more than the number of wires of the sizes and types indicated in the following tables. Intended to enclose circuits operating at potentials not exceeding 600 volts between conductors. In all cases, the B217-20 or B217P snap-in cover is required to complete raceway closure. When using B217-24 snap-in cover, the number of wires is limited to 7 or fewer conductors no larger than #12 AWG.

B-Line's strut-type channel raceways and fittings are manufactured and tested to comply with the UL Standard for Safety for Strut-Type Channel Raceways and Fittings (UL 5B) in accordance with Article 384 of the 2002 National Electrical Code, NFPA 70.

1. Support spans for strut-type channel raceway shall not exceed 10 foot intervals.
2. No conductor larger than that for which the raceway is listed shall be installed in strut-type channel raceways. No wires under 14AWG or over 6AWG are allowed in any of B-Line's strut-type channel raceway. See tables 1, 2 and 3 below for a listing of the approved conductors for B-Line's strut-type channel raceways.
3. The number of conductors permitted in strut-type channel raceway shall not exceed the percentage fill using Table 384-22 and the applicable outside diameter of specific types and sizes of wire given in the tables in chapter 9 of the National Electrical Code. Table 384-22 lists two different percent fill areas depending on the use of internal or external joiners. Use 40% area fill with external joiners and 25% area fill for internal joiners.
4. Items in the electrical section of the B-Line Strut Systems Catalog identified by the UL symbol provide for electrical continuity. Other items require the use of a separate grounding wire.
5. If strut-type channel raceway is connected to another wiring system, the raceway must be field-tapped adjacent to the wire entry point to accept a #10-32 or larger grounding screw. A plated or stainless steel screw may be used. A sheet metal screw is not acceptable. Drill and tap the grounding wire hole before installing wires in raceway or move installed wires out of the way to avoid damage. After drilling and tapping, remove metal chips and burrs before installing screw.

TABLE 1: MAXIMUM NUMBER OF WIRES (Adjusted per NEC Table 384.22 for 40% fill)

Use this table to determine the type and number of conductors for use with B-Line's strut-type channel raceway using external joiners. This table applies for all installations except for the support and supply of electric discharge type lighting fixtures. See table 2 and 3 for further information.

Insulation Type	Wire Size AWG.	B11 B11K06	B12 B12K06	B22 B22K06	B24 B24K06	B26 B26K06	B32 B32K06	B56 B56K06
FEP, FEPB	14	172	127	81	81	81	67	36
	12	126	92	59	59	59	49	26
	10	90	66	42	42	42	35	19
	8	51	38	24	24	24	20	11
	6	24	17	11	12	12	9	5
RH, RHH, RHW	14	52	38	24	26	27	20	12
	12	45	33	21	22	23	17	10
	10	37	27	17	18	19	14	8
	8	20	14	9	10	10	7	4
	6	14	10	6	7	7	5	3
T, TW	14	124	91	58	58	58	48	26
	12	95	70	45	45	45	37	20
	10	69	51	33	33	33	27	14
	8	36	26	17	18	19	14	8
	6	21	15	9	10	11	8	5
THHN, THWN	14	178	131	84	84	84	69	37
	12	130	95	61	61	61	50	27
	10	82	60	38	38	38	32	17
	8	46	34	21	22	22	17	10
	6	33	24	15	16	16	12	7
THW	14	82	61	39	39	39	32	17
	12	66	49	31	31	31	26	14
	10	52	38	24	24	24	20	11
	8	29	21	13	14	15	11	6
	6	21	15	10	10	11	8	5
XHHW	14	124	91	58	58	58	48	26
	12	95	70	45	45	45	37	20
	10	71	52	33	33	33	28	15
	8	37	27	17	19	19	14	8
	6	27	20	13	14	14	10	6

TABLE 2: MAXIMUM NUMBER OF WIRES

Also suitable for the number of wires in table below when installed to support and supply *electric discharge type lighting fixtures* when raceway wiring is suitable for at least **70°C** and **clearance between fixture and raceway is at least 1/8"**. In all cases, a snap-in cover is required to complete the raceway enclosure.

Wire Size	Raceway Catalog Wires						
	B11 B11K06	B12 B12K06	B22 B22K06	B24 B24K06	B26 B26K06	B32 B32K06	B56 B56K06
Type Insulation: FEP, FEPB, RH, RHH, RHW, RUH, THHN, THWN, THW, XHHW							
14	13	10	10	10	10	10	6
12	13	10	10	10	10	10	6
10	13	10	8	8	8	6	–
8	10	8	6	6	6	4	–
6	8	6	4	4	4	3	–

When using B217-24 snap-in cover, the number of wires is limited to 7 or fewer conductors no larger than #12 AWG.

TABLE 3: MAXIMUM NUMBER OF WIRES









Also suitable for the number of wires in table below when installed to support and supply *electric discharge type lighting fixtures* when raceway wiring is suitable for 75°C, **or** wiring suitable for 60°C **if a minimum clearance between fixture and raceway is at least 1/2"**. In all cases, a snap-in cover is required to complete the raceway enclosure.

Wire Size	Raceway Catalog Wires						
	B11 B11K06	B12 B12K06	B22 B22K06	B24 B24K06	B26 B26K06	B32 B32K06	B56 B56K06
Type Insulation: FEP, FEPB, RH, RHH, RHW, RUH, THHN, THWN, THW, XHHW							
14	10	10	10	10	10	10	4
12	10	10	10	10	10	10	3
10	8	5	5	5	5	5	–
8	6	4	4	4	4	4	–
6	4	4	4	4	4	4	–

When using B217-24 snap-in cover, the number of wires is limited to 7 or fewer conductors no larger than #12 AWG.

Reference Data

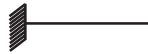
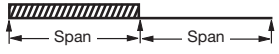
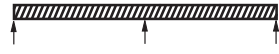
The data shown in the beam load charts for appropriate channels on page(s) 17 thru 39 is for simply supported, single span beams with a uniformly distributed load. For other loading and/or support conditions, use the appropriate factor from the chart below.

Load and Support Condition	Load Factor	Deflection Factor
Simple Beam - Uniform Load 	1.00	1.00
Simple Beam - Concentrated Load at Center 	.50	.80
Simple Beam - Two Equal Concentrated Loads at 1/4 Points 	1.00	1.10
Beam Fixed at Both Ends - Uniform Load 	1.50	.30
Beam Fixed at Both Ends - Concentrated Load at Center 	1.00	.40
Cantilever Beam - Uniform Load 	.25	2.40
Cantilever Beam - Concentrated Load at End 	.12	3.20
Continuous Beam - Two Equal Spans - Uniform Load on One Span 	1.30	.92
Continuous Beam - Two Equal Spans - Concentrated Load on Both Spans 	1.00	.42
Continuous Beam - Two Equal Spans - Concentrated Load at Center of One Span 	.62	.71
Continuous Beam - Two Equal Spans - Concentrated Load at Center of Both Spans 	.67	.48

EXAMPLES:

PROBLEM:

Calculate the maximum allowable load and corresponding deflection of a simply supported B22 beam with a concentrated load at midspan as shown.



SOLUTION:

From beam load chart for B22 (page 22), maximum allowable load is A and the corresponding deflection is B. Multiplying by the appropriate factors shown in the chart above.

LOAD = A x load factor = _____
 DEFLECTION = B x deflection factor = _____

PROBLEM:

Calculate the maximum allowable load and corresponding deflection of a cantilever B52 beam with a uniformly distributed load.



SOLUTION:

From beam load chart for B52 (page 33), maximum allowable load is A and the corresponding deflection is B. Multiplying by the appropriate factors shown in chart above.

LOAD = A x load factor = _____
 DEFLECTION = B x deflection factor = _____

RIGID STEEL CONDUIT (HEAVY WALL CONDUIT)

Nominal Conduit Size		Outside Diameter		Nominal Inside Diameter		Minimum Weight Per 100 Ft. (30.5m) with Couplings Attached		Weight of Conduit and Conductors Per 100 Ft. (30.5m)*	
In.	mm	In.	mm	In.	mm	Lbs.	kg	Lbs.	kg
3/8"	(10)	0.675	(17.1)	0.493	(12.5)	51.5	(23.4)	65.1	(29.5)
1/2"	(15)	0.840	(21.3)	0.632	(16.0)	79.0	(35.8)	101.1	(45.9)
3/4"	(20)	1.050	(26.7)	0.836	(21.3)	105.0	(47.6)	145.8	(66.1)
1"	(25)	1.315	(33.4)	1.063	(27.0)	153.0	(69.4)	219.3	(99.5)
1 1/4"	(32)	1.660	(42.2)	1.394	(35.4)	201.0	(91.2)	318.3	(144.4)
1 1/2"	(40)	1.900	(48.3)	1.624	(41.3)	249.0	(113.0)	408.8	(185.4)
2"	(50)	2.375	(60.3)	2.083	(52.9)	332.0	(150.6)	593.8	(269.3)
2 1/2"	(65)	2.875	(73.0)	2.489	(63.2)	527.0	(239.1)	901.0	(408.7)
3"	(80)	3.500	(88.9)	3.090	(78.5)	682.6	(309.6)	1259.0	(571.1)
3 1/2"	(90)	4.000	(101.6)	3.570	(90.7)	831.0	(376.9)	1604.0	(727.6)
4"	(100)	4.500	(114.3)	4.050	(102.9)	972.3	(441.0)	1967.0	(892.2)
5"	(125)	5.563	(141.3)	5.073	(128.9)	1313.6	(595.9)	2876.0	(1304.5)
6"	(150)	6.625	(168.3)	6.093	(154.8)	1745.3	(791.7)	4003.0	(1815.7)

Dimensions taken from ANSI C80.1-1977.

*Conduit plus weight of heaviest conductor combination as specified by the National Electrical Code.

INTERMEDIATE METAL CONDUIT (IMC)

Nominal Conduit Size		Outside Diameter		Nominal Inside Diameter		Minimum Weight Per 100 Ft. (30.5m) with Couplings Attached		Weight of Conduit and Conductors Per 100 Ft. (30.5m)*	
In.	mm	In.	mm	In.	mm	Lbs.	kg	Lbs.	kg
1/2"	(15)	0.815	(20.7)	.675	(17.1)	60.0	(27.2)	82.1	(37.2)
3/4"	(20)	1.029	(26.1)	.879	(22.3)	82.0	(37.2)	122.8	(55.7)
1"	(25)	1.290	(32.7)	1.120	(28.4)	116.0	(52.6)	182.3	(82.7)
1 1/4"	(32)	1.638	(41.6)	1.468	(37.3)	150.0	(68.0)	267.3	(121.2)
1 1/2"	(40)	1.883	(47.7)	1.703	(43.3)	182.0	(82.5)	341.8	(155.0)
2"	(50)	2.360	(59.9)	2.170	(55.1)	242.0	(109.7)	503.8	(228.5)
2 1/2"	(65)	2.857	(72.5)	2.597	(66.0)	428.0	(194.1)	775.0	(351.5)
3"	(80)	3.476	(88.3)	3.216	(81.7)	526.0	(238.6)	1069.0	(485.0)
3 1/2"	(90)	3.971	(100.8)	3.711	(94.3)	612.0	(277.6)	1346.0	(610.8)
4"	(100)	4.466	(113.4)	4.206	(106.8)	682.0	(309.4)	1632.0	(740.5)

*Conduit plus weight of heaviest conductor combination as specified by the National Electrical Code.

Rigid and Intermediate Metal Conduit shall be supported at least every 10 feet (3.05 m) and within 3 feet (914 mm) of each outlet box, junction box, cabinet, or fitting, except for straight runs of conduit connected with couplings which may be supported in accordance with NEC Article 345 and 346, provided such supports prevent transmission of stresses to termination where conduit is deflected between supports.

NEC TABLE 346-12

Conduit Size		Maximum Support Span	
In.	mm	Feet	Meters
1/2-3/4	(15-20)	10	(3.05)
1	(25)	12	(3.66)
1 1/4-1 1/2	(32-40)	14	(4.27)
2-2 1/2	(50-65)	16	(4.88)
3-6	(80-150)	20	(6.10)

Reference Data

ELECTRICAL METALLIC TUBING (EMT) – THINWALL CONDUIT

Nominal Conduit Size		Outside Diameter		Inside Diameter		Weight Per 100 Ft. (30.5m)		Weight of Conduit and Conductors Per 100 Ft. (30.5m)*	
In.	mm	In.	mm	In.	mm	Lbs.	kg	Lbs.	kg
3/8"	(10)	0.577	(14.7)	0.493	(12.5)	23.0	(10.4)	36.6	(16.6)
1/2"	(15)	0.706	(17.9)	0.622	(15.8)	28.5	(12.9)	50.6	(23.0)
3/4"	(20)	0.922	(23.4)	0.824	(20.9)	43.5	(19.7)	84.3	(38.2)
1"	(25)	1.163	(29.5)	1.049	(26.6)	64.0	(29.0)	130.3	(59.1)
1 1/4"	(32)	1.510	(38.3)	1.380	(35.1)	95.0	(43.1)	212.3	(96.3)
1 1/2"	(40)	1.740	(44.2)	1.610	(40.9)	110.0	(49.9)	269.8	(122.4)
2"	(50)	2.197	(55.8)	2.067	(52.5)	140.0	(63.5)	401.8	(182.3)
2 1/2"	(65)	2.875	(73.0)	2.731	(69.4)	205.0	(93.0)	579.0	(262.6)
3"	(80)	3.500	(88.9)	3.356	(85.2)	250.0	(113.4)	826.3	(374.8)
3 1/2"	(90)	4.000	(101.6)	3.834	(97.4)	325.0	(147.4)	1098.0	(498.0)
4"	(100)	4.500	(114.3)	4.334	(110.1)	370.0	(167.8)	1364.0	(618.7)

Dimensions taken from ANSI C80.3-1977.

*Conduit plus weight of heaviest conductor combination as specified by the National Electrical Code.

Electrical Metallic tubing shall be supported at least every 10 feet (3.05 m) and within 3 feet (914 mm) of each outlet box, junction box, cabinet, or fitting. See NEC Article 348.

RIGID ALUMINUM CONDUIT

Nominal Conduit Size		Outside Diameter		Nominal Inside Diameter		Minimum Weight Per 100 Ft. (30.5m) with Couplings Attached		Weight of Conduit and Conductors Per 100 Ft. (30.5m)*	
In.	mm	In.	mm	In.	mm	Lbs.	kg	Lbs.	kg
1/2"	(15)	0.840	(21.3)	0.632	(16.1)	27.4	(12.4)	49.5	(22.5)
3/4"	(20)	1.050	(26.7)	0.836	(21.2)	36.4	(16.5)	77.2	(35.0)
1"	(25)	1.315	(33.4)	1.063	(27.0)	53.0	(24.0)	119.3	(54.1)
1 1/4"	(32)	1.660	(42.2)	1.394	(35.4)	69.6	(31.6)	186.9	(84.8)
1 1/2"	(40)	1.900	(48.3)	1.624	(41.2)	82.2	(37.3)	242.0	(109.8)
2"	(50)	2.375	(60.3)	2.083	(52.9)	115.7	(52.5)	377.5	(171.2)
2 1/2"	(65)	2.875	(73.0)	2.489	(63.2)	182.5	(82.8)	556.5	(252.4)
3"	(80)	3.500	(88.9)	3.090	(78.5)	238.9	(108.4)	815.2	(369.8)
3 1/2"	(90)	4.000	(101.6)	3.570	(90.7)	287.7	(130.5)	1061.0	(481.3)
4"	(100)	4.500	(114.3)	4.050	(102.9)	340.0	(154.2)	1334.0	(605.1)
5"	(125)	5.563	(141.3)	5.073	(128.9)	465.4	(211.1)	2028.0	(919.9)
6"	(150)	6.625	(168.3)	6.093	(154.8)	612.5	(277.8)	2870.0	(1301.8)

Dimensions taken from ANSI C80.5-1977.

*Conduit plus weight of heaviest conductor combination as specified by the National Electrical Code.

Aluminum Rigid Conduit shall be supported at least every 10 feet (3.05 m) and within 3 feet (914 mm) of each outlet box, junction box, cabinet, or fitting, except for straight runs of conduit connected with couplings which may be supported in accordance with NEC Table 344.30 (B)(2), provided such supports prevent transmission of stresses to termination where conduit is deflected between supports.

NEC TABLE 344.30 (B)(2)

Conduit Size		Maximum Support Span	
In.	mm	Feet	Meters
1/2-3/4	(15-20)	10	(3.05)
1	(25)	12	(3.66)
1 1/4-1 1/2	(32-40)	14	(4.27)
2-2 1/2	(50-65)	16	(4.88)
3-6	(80-150)	20	(6.10)

SCHEDULE 40 PVC PLASTIC PIPE

Nominal Pipe Size		Outside Diameter		Inside Diameter		Weight of Pipe Per 100 Ft. (30.5m)		Weight of Pipe Filled With Water Per 100 Ft. (30.5m)	
In.	mm	In.	mm	In.	mm	Lbs.	kg	Lbs.	kg
1/8"	(3)	.405	(10.3)	.269	(6.8)	4.7	(2.1)	7.2	(3.2)
1/4"	(6)	.540	(13.7)	.364	(9.2)	8.2	(3.7)	12.7	(5.8)
3/8"	(10)	.675	(17.1)	.493	(12.5)	10.9	(4.9)	19.2	(8.7)
1/2"	(15)	.840	(21.3)	.622	(15.8)	16.4	(7.4)	29.6	(13.4)
3/4"	(20)	1.050	(26.7)	.824	(20.9)	21.8	(9.9)	44.9	(20.4)
1"	(25)	1.315	(33.4)	1.049	(26.6)	32.1	(14.6)	69.6	(31.6)
1 1/4"	(32)	1.660	(42.2)	1.380	(35.1)	43.4	(19.7)	108.2	(49.1)
1 1/2"	(40)	1.900	(48.3)	1.610	(40.9)	51.8	(23.5)	140.0	(63.5)
2"	(50)	2.375	(60.3)	2.067	(52.5)	69.5	(31.5)	214.9	(97.5)
2 1/2"	(65)	2.875	(73.0)	2.469	(62.7)	109.6	(49.7)	317.1	(143.8)
3"	(80)	3.500	(88.9)	3.068	(77.9)	143.5	(65.1)	463.9	(210.4)
3 1/2"	(90)	4.000	(101.6)	3.548	(90.1)	175.6	(79.7)	604.1	(274.0)
4"	(100)	4.500	(114.3)	4.026	(102.3)	204.3	(92.7)	756.0	(342.9)
5"	(125)	5.563	(141.3)	5.047	(128.2)	281.7	(127.8)	1148.8	(521.1)
6"	(150)	6.625	(168.3)	6.065	(154.1)	360.9	(163.7)	1613.0	(731.7)
8"	(200)	8.625	(219.1)	7.981	(202.7)	545.3	(247.3)	2713.5	(1230.8)
10"	(250)	10.750	(273.1)	10.020	(254.5)	791.3	(358.9)	4208.9	(1909.1)
12"	(300)	12.750	(323.9)	11.938	(303.2)	1035.2	(469.6)	5886.4	(2670.0)

1 cubic ft. of water weighs 62.41 Lbs.
 1 cubic meter of water weighs 999.972 kg.
 1 gallon (U.S.) weighs 8.335 Lbs.
 1 liter weighs .999 kg.

CLAMP SIZING CHART FOR PVC COATED RIGID CONDUIT AND CLAMPS

Nominal Conduit Size		Conduit Coating			
		.020 (.51mm)		.040 (1.01mm)	
		Clamp Coating 0	.020 (.51mm)	Clamp Coating 0	.020 (.51mm)
1/2"	(15)	B2028	B2002	B2002	B2029
3/4"	(20)	B2030	B2030	B2030	B2003
1"	(25)	B2032	B2032	B2032	B2033
1 1/4"	(32)	B2005	B2005	B2005	B2005
1 1/2"	(40)	B2012	B2037	B2037	B2037
2"	(50)	B2013	B2041	B2041	B2041
2 1/2"	(65)	B2014	B2045	B2045	B2045
3"	(80)	B2015	B2050	B2050	B2050
3 1/2"	(90)	B2016	B2054	B2054	B2054
4"	(100)	B2017	B2058	B2058	B2058
5"	(125)	B2019	B2066	B2066	B2066
6"	(150)	B2020	B2115	B2115	B2115

ALL THREADED ROD (ATR)

Nominal Size (In) and Thread	Root Area		Design Load (SF=5)	
	In. ²	cm ²	Lbs.	kN
1/4-20"	0.027	(0.174)	240	(1.07)
5/16-18"	0.045	(0.290)	400	(1.78)
3/8-16"	0.068	(0.438)	730	(3.24)
1/2-13"	0.126	(0.812)	1350	(6.00)
5/8-11"	0.202	(1.303)	2160	(9.60)
3/4-10"	0.302	(1.948)	3230	(14.37)
7/8-9"	0.419	(2.703)	4480	(19.93)
1-8"	0.551	(3.561)	5900	(26.24)
1 1/8-7"	0.693	(4.471)	7450	(33.14)
1 1/4-7"	0.889	(5.735)	9500	(42.25)
1 1/2-6"	1.293	(8.342)	13800	(61.38)

Dimensions taken from ANSI B1.1-1982 Unified Inch Screw Threads. All threads are UNCR series.

Tabulated loads are based on an allowable tensile stress of 12000 psi (82.7 MPa) reduced by 25% resulting in 9000 psi (62 MPa). From ANSI/MSS SP-58, Table 3.

CLAMP SIZING CHART FOR PVC COATED THINWALL (EMT) CONDUIT AND CLAMPS

Nominal Conduit Size		Conduit Coating			
		.020 (.51mm)		.040 (1.01mm)	
		Clamp Coating 0	.020 (.51mm)	Clamp Coating 0	.020 (.51mm)
3/8"	(10)	B2026	B2026	B2026	B2007
1/2"	(15)	B2027	B2027	B2027	B2008
3/4"	(20)	B2029	B2029	B2029	B2009
1"	(25)	B2003	B2031	B2031	B2031
1 1/4"	(32)	B2004	B2034	B2034	B2034
1 1/2"	(40)	B2035	B2035	B2035	B2036
2"	(50)	B2039	B2039	B2039	B2013

Reference Data

COPPER TUBING, TYPE L

Nominal Tubing Size		Outside Diameter		Inside Diameter		Weight of Tubing Per 100 Ft. (30.5m)		Weight of Tubing Filled With Water Per 100 Ft. (30.5m)	
In.	mm	In.	mm	In.	mm	Lbs.	kg	Lbs.	kg
1/4"	(6)	.375	(9.5)	.315	(8.0)	12.6	(5.7)	16.0	(7.2)
3/8"	(10)	.500	(12.7)	.430	(10.9)	19.8	(9.0)	26.1	(11.8)
1/2"	(15)	.625	(15.9)	.545	(13.8)	28.5	(12.9)	38.6	(17.5)
5/8"	(17)	.750	(19.1)	.666	(16.9)	36.2	(16.4)	51.3	(23.3)
3/4"	(20)	.875	(22.2)	.785	(19.9)	45.5	(20.6)	66.5	(30.2)
1"	(25)	1.125	(28.6)	1.025	(26.0)	65.5	(29.7)	101.3	(45.9)
1 1/4"	(32)	1.375	(34.9)	1.265	(32.1)	88.4	(40.1)	142.9	(64.8)
1 1/2"	(40)	1.625	(41.3)	1.505	(38.2)	114.0	(51.7)	191.1	(86.7)
2"	(50)	2.125	(54.0)	1.985	(50.4)	175.0	(79.4)	309.1	(140.2)
2 1/2"	(65)	2.625	(66.7)	2.465	(62.6)	248.0	(112.5)	454.8	(206.3)
3"	(80)	3.125	(79.4)	2.945	(74.8)	333.0	(151.0)	628.2	(285.0)
3 1/2"	(90)	3.625	(92.1)	3.425	(87.0)	429.0	(194.6)	828.3	(375.7)
4"	(100)	4.125	(104.8)	3.905	(99.2)	538.0	(244.0)	1057.1	(479.5)
5"	(125)	5.125	(130.2)	4.875	(123.8)	761.0	(345.2)	1570.0	(712.1)
6"	(150)	6.125	(155.6)	5.845	(148.5)	1020.0	(462.7)	2182.9	(990.2)
8"	(200)	8.125	(206.4)	7.725	(196.2)	1930.0	(875.4)	3961.3	(1796.8)
10"	(250)	10.125	(257.2)	9.625	(244.5)	3010.0	(1365.3)	6163.4	(2795.7)
12"	(300)	12.125	(308.0)	11.565	(293.8)	4040.0	(1832.5)	8592.8	(3897.6)

COPPER TUBING, TYPE K

Nominal Tubing Size		Outside Diameter		Inside Diameter		Weight of Tubing Per 100 Ft. (30.5m)		Weight of Tubing Filled With Water Per 100 Ft. (30.5m)	
In.	mm	In.	mm	In.	mm	Lbs.	kg	Lbs.	kg
1/4"	(6)	.375	(9.5)	.305	(7.7)	14.5	(6.6)	17.7	(8.0)
3/8"	(10)	.500	(12.7)	.402	(10.2)	26.9	(12.2)	32.4	(14.7)
1/2"	(15)	.625	(15.9)	.527	(13.4)	34.4	(15.6)	43.9	(19.9)
5/8"	(17)	.750	(19.1)	.652	(16.6)	41.8	(19.0)	56.3	(25.5)
3/4"	(20)	.875	(22.2)	.745	(18.9)	64.1	(29.1)	83.0	(37.6)
1"	(25)	1.125	(28.6)	.995	(25.3)	83.9	(38.1)	117.6	(53.3)
1 1/4"	(32)	1.375	(34.9)	1.245	(31.6)	104.0	(47.2)	156.8	(71.1)
1 1/2"	(40)	1.625	(41.3)	1.481	(37.6)	136.0	(61.7)	210.7	(95.6)
2"	(50)	2.125	(54.0)	1.959	(49.8)	206.0	(93.4)	336.6	(152.7)
2 1/2"	(65)	2.625	(66.7)	2.435	(61.8)	293.0	(132.9)	494.8	(224.5)
3"	(80)	3.125	(79.4)	2.907	(73.8)	400.0	(181.4)	687.7	(311.9)
3 1/2"	(90)	3.625	(92.1)	3.385	(86.0)	512.0	(232.2)	902.0	(409.2)
4"	(100)	4.125	(104.8)	3.857	(98.0)	651.0	(295.3)	1157.4	(525.0)
5"	(125)	5.125	(130.2)	4.805	(122.0)	967.0	(438.6)	1752.9	(795.1)
6"	(150)	6.125	(155.6)	5.741	(145.8)	1390.0	(630.5)	2511.9	(1139.4)
8"	(200)	8.125	(206.4)	7.583	(192.6)	2590.0	(1174.8)	4547.3	(2062.6)
10"	(250)	10.125	(257.2)	9.449	(240.0)	4030.0	(1828.0)	7069.2	(3206.5)
12"	(300)	12.125	(308.0)	11.315	(287.4)	5780.0	(2621.8)	10138.0	(4598.5)

Dimensions taken from ASTM B 88-83.

- 1 cubic ft. of water weighs 62.41 Lbs.
- 1 cubic meter of water weighs 999.972 kg.
- 1 gallon (U.S.) weighs 8.335 Lbs.
- 1 liter weighs .999 kg.

STANDARD WEIGHT SCHEDULE 40 STEEL PIPE

Nominal Pipe Size		Outside Diameter		Inside Diameter		Nominal Weight Per 100 Ft. (30.5mm) Plain End		Weight of Pipe Filled With Water Per 100 Ft. (30.5mm)	
In.	mm	In.	mm	In.	mm	Lbs.	kg	Lbs.	kg
3/8"	(10)	.675	(17.1)	.493	(12.5)	57.0	(25.9)	65.3	(29.6)
1/2"	(15)	.840	(21.3)	.622	(15.8)	85.0	(38.6)	98.2	(44.5)
3/4"	(20)	1.050	(26.7)	.824	(20.9)	113.0	(51.3)	136.1	(61.7)
1"	(25)	1.315	(33.4)	1.049	(26.6)	168.0	(76.2)	205.5	(93.2)
1 1/4"	(32)	1.660	(42.2)	1.380	(35.1)	227.0	(103.0)	291.8	(132.4)
1 1/2"	(40)	1.900	(48.3)	1.610	(40.9)	272.0	(123.4)	360.2	(163.4)
2"	(50)	2.375	(60.3)	2.067	(52.5)	365.0	(165.6)	510.4	(231.5)
2 1/2"	(65)	2.875	(73.0)	2.469	(62.7)	579.0	(262.6)	786.5	(356.8)
3"	(80)	3.500	(88.9)	3.068	(77.9)	758.0	(343.8)	1078.4	(489.2)
3 1/2"	(90)	4.000	(101.9)	3.548	(90.1)	911.0	(413.2)	1339.5	(607.6)
4"	(100)	4.500	(114.3)	4.026	(102.3)	1079.0	(489.4)	1630.7	(739.7)
5"	(125)	5.563	(141.3)	5.047	(128.2)	1462.0	(663.2)	2329.1	(1056.4)
6"	(150)	6.625	(168.3)	6.065	(154.1)	1897.0	(860.5)	3149.1	(1428.4)
8"	(200)	8.625	(219.1)	7.981	(202.7)	2855.0	(1295.0)	5023.2	(2278.5)
10"	(250)	10.750	(273.1)	10.020	(254.5)	4048.0	(1836.1)	7465.6	(3386.3)
12"	(300)	12.750	(323.9)	12.000	(304.8)	4956.0	(2248.0)	9857.7	(4471.4)
14"	(350)	14.000	(355.6)	13.250	(336.6)	5457.0	(2475.3)	11433.1	(5185.9)
16"	(400)	16.000	(406.4)	15.250	(387.4)	6258.0	(2838.6)	14174.3	(6429.4)
18"	(450)	18.000	(457.2)	17.250	(438.2)	7059.0	(3201.9)	17187.9	(7796.3)
20"	(500)	20.000	(508.0)	19.250	(489.0)	7860.0	(3565.2)	20473.7	(9286.7)
24"	(600)	24.000	(609.6)	23.250	(590.6)	9462.0	(4291.9)	27862.5	(12638.2)

Dimensions taken from ASTM A 53-82.

- 1 cubic ft. of water weighs 62.41 Lbs.
- 1 cubic meter of water weighs 999.972 kg.
- 1 gallon (U.S.) weighs 8.335 Lbs.
- 1 liter weighs .999 kg.

TRAPEZE HANGERS USING B-LINE STRUT OR ANGLE IRON

Length of Trapeze Bar	Nominal Pipe Sizes							
	2 1/2" (65mm) or less	3" (80mm)	3 1/2" (90mm)	4" (100mm)	5" (125mm)	6" (150mm)	8" (200mm)	10" (250mm)
1'-6" (0.46m)	1 1/2" x 1 1/2" x 3/16" B24SH	1 1/2" x 1 1/2" x 3/16" B24SH	1 1/2" x 1 1/2" x 3/16" B24SH	2" x 1 1/2" x 3/16" B22SH	2" x 1 1/2" x 3/16" B22SH	2 1/2" x 1 1/2" x 3/16" B12SH	3" x 2" x 3/16" B11SH	3" x 2" x 1/4" B11SH
2'-0" (0.61m)	1 1/2" x 1 1/2" x 3/16" B24SH	2" x 1 1/2" x 3/16" B22SH	2" x 1 1/2" x 3/16" B22SH	2" x 1 1/2" x 3/16" B22SH	2 1/2" x 1 1/2" x 3/16" B12SH	2 1/2" x 1 1/2" x 3/16" B12SH	3" x 2" x 3/16" B11SH	3" x 2" x 1/4" B11SH
2'-6" (0.76m)	2" x 1 1/2" x 3/16" B22SH	2" x 1 1/2" x 3/16" B22SH	2" x 1 1/2" x 3/16" B22SH	2 1/2" x 1 1/2" x 3/16" B12SH	2 1/2" x 1 1/2" x 3/16" B12SH	3" x 2" x 3/16" B11SH	3" x 2" x 1/4" B11SH	3" x 2" x 1/4" B11SH
3'-0" (0.91m)	2" x 1 1/2" x 3/16" B22SH	2" x 1 1/2" x 3/16" B22SH	2 1/2" x 1 1/2" x 3/16" B12SH	2 1/2" x 1 1/2" x 3/16" B12SH	3" x 2" x 3/16" B11SH	3" x 2" x 3/16" B11SH	3 1/2" x 2 1/2" x 5/16" B12SHA	3 1/2" x 2 1/2" x 5/16" B12SHA
4'-0" (1.22m)	2 1/2" x 1 1/2" x 3/16" B12SH	2 1/2" x 1 1/2" x 3/16" B12SH	2 1/2" x 1 1/2" x 3/16" B12SH	3" x 2" x 3/16" B11SH	3" x 2" x 3/16" B11SH	3" x 2" x 1/4" B11SH	3 1/2" x 2 1/2" x 5/16" B12SHA	4" x 3" x 5/16" B12SHA
5'-0" (1.52m)	2 1/2" x 1 1/2" x 3/16" B12SH	2 1/2" x 1 1/2" x 3/16" B12SH	3" x 2" x 3/16" B11SH	3" x 2" x 3/16" B11SH	3" x 2" x 1/4" B11SH	3 1/2" x 2 1/2" x 5/16" B12SHA	4" x 3" x 5/16" B12SHA	5" x 3 1/2" x 5/16" B11SHA
6'-0" (1.83m)	2 1/2" x 1 1/2" x 3/16" B12SH	3" x 2" x 3/16" B11SH	3" x 2" x 3/16" B11SH	3" x 2" x 1/4" B11SH	3 1/2" x 2 1/2" x 5/16" B12SHA	4" x 3" x 5/16" B12SHA	4" x 3" x 5/16" B12SHA	5" x 3 1/2" x 5/16" B11SHA
7'-0" (2.13m)	3" x 2" x 3/16" B11SH	3" x 2" x 3/16" B11SH	3" x 2" x 1/4" B11SH	3" x 2" x 1/4" B11SH	3 1/2" x 2 1/2" x 5/16" B12SHA	4" x 3" x 5/16" B12SHA	5" x 3 1/2" x 5/16" B11SHA	6" x 4" x 1/4" 2-B12SHA
8'-0" (2.44m)	3" x 2" x 3/16" B11SH	3" x 2" x 1/4" B11SH	3" x 2" x 1/4" B11SH	3 1/2" x 2 1/2" x 5/16" B12SHA	3 1/2" x 2 1/2" x 5/16" B12SHA	4" x 3" x 5/16" B12SHA	5" x 3 1/2" x 5/16" B11SHA	6" x 4" x 1/4" 2-B12SHA
9'-0" (2.74m)	3" x 2" x 3/16" B11SH	3" x 2" x 1/4" B11SH	3 1/2" x 2 1/2" x 5/16" B12SHA	3 1/2" x 2 1/2" x 5/16" B12SHA	3 1/2" x 2 1/2" x 5/16" B12SHA	4" x 3" x 5/16" B12SHA	5" x 3 1/2" x 5/16" B11SHA	6" x 4" x 3/8" 2-B11SHA
10'-0" (3.05m)	3" x 2" x 1/4" B11SH	3" x 2" x 1/4" B11SH	3 1/2" x 2 1/2" x 5/16" B12SHA	3 1/2" x 2 1/2" x 5/16" B12SHA	4" x 3" x 5/16" B12SHA	5" x 3 1/2" x 5/16" B11SHA	6" x 4" x 1/4" 2-B12SHA	6" x 4" x 3/8" 2-B11SHA

REFERENCE: Table 3-14.1.6 standard for the installation of Sprinkler Systems, NFPA No. 13-1985, published by National Fire Protection Association.

Tolco™ to B-Line Cross Reference

Tolco to B-Line Cross

Tolco Fig#	B-Line Pt. #	Tolco Fig#	B-Line Pt. #	Tolco Fig#	B-Line Pt. #
2 STR 1/2"	B2400-1/2	BC-14-5/8	B321-4	BR-22-12	B409-12
2 STR 3/4"	B2400-3/4	BC-14-3/4	B321-5	BR-22-18	B409-18
2 STR 1"	B2400-1	BC-16	B314	BR-22-24	B409-25
2 STR 1 1/4"	B2400-1 1/4	BC-17	B441-22	C SAFETY END CAP	B852
2 STR 1 1/2"	B2400-1 1/2	BC-18-3/8	B212-3/8	C-14	B54
2 STR 2"	B2400-2	BC-18-1/2	B212-1/2	C-14 END CAP	B204
2 STR 2 1/2"	B2400-2 1/2	BC-19	B427	CL-10	B217-20
2 STR 3"	B2400-3	BC-20	B355	CR ISOLATOR	ISO
2 STR 3 1/2"	B2400-3 1/2	BC-21	B211	CUSH CLP 1/4	BVT025
2 STR 4"	B2400-4	BC-23	B614	CUSH CLP 3/8	BVT037
2 STR 5"	B2400-5	BC-70	B760-22 Series	CUSH CLP 1/2	BVT050
2 STR 6"	B2400-6	BC-71	B760-22A Series	CUSH CLP 5/8	BVT062
2 STR 8"	B2400-8	BC-72	B761-22 Series	CUSH CLP 3/4	BVT075
65XT	N/C	BC-73	B761-22A Series	CUSH CLP 1	BVT100
69	B3367	BR-10-8L	B185SHL	CUSH CLP 1 1/8	BVT112
69R	N/C	BR-10-8R	B185SHR	CUSH CLP 1 1/4	BVT125
75	N/C	BR-10-10L	B186SHL	CUSH CLP 1 3/8	BVT137
98	SC228	BR-10-10R	B186SHR	CUSH CLP 1 1/2	BVT150
98B	N/C	BR-10-12L	B178SHL	CUSH CLP 1 5/8	BVT162
310	B2501	BR-10-12R	B178SHR	CUSH CLP 1 3/4	BVT175
310N 1/4	N2501-1/4	BR-10-18L	B181SHL	CUSH CLP 2	BVT200
310N 3/8	N2501-3/8	BR-10-18R	B181SHR	CUSH CLP 2 1/8	BVT212
310N 1/2	N2501-1/2	BR-10-20L	B182SHL	CUSH CLP 2 1/2	BVT250
310N 5/8	N2501-5/8	BR-10-20R	B182SHR	CUSH CLP 2 5/8	BVT262
310N 3/4	N2501-3/4	BR-11-8 1/2	B187	CUSH CLP 3	BVT300
310N 7/8	N2501-7/8	BR-11-10 1/2	B541	CUSH CLP 3 1/8	BVT312
902	B335V	BR-11-12 1/2	B289-12	CUSH CLP 3 5/8	BVT362
912	B335-1	BR-11-14 1/2	B289-14	CUSH CLP 4	BVT400
913	B335-2	BR-11-22	B292	CUSH CLP 4 5/8	N/A
914	B335	BR-12	B290	CUSH CLP 5 1/8	N/A
915	B634	BR-13	B194	CUSH CLP 6 1/8	BVT612
915D	B635	BR-14	B370	CUSH CLP IPS 1/4	BVP025
A SAFETY END CAP	B822	BR-15-18	B196-18	CUSH CLP IPS 3/8	BVP037
A-12	B22	BR-15-24	B196-24	CUSH CLP IPS 1/2	BVP050
A-12 End Cap	B205	BR-16-6	B198A-6	CUSH CLP IPS 3/4	BVP075
A-12 End Spot	B3322	BR-16-12	B198A-12	CUSH CLP IPS 1	BVP100
A-14	B24	BR-17-12	B297-12	CUSH CLP IPS 1 1/4	BVP125
A-14 End Cap	B223	BR-17-18	B297-18	CUSH CLP IPS 1 1/2	BVP150
BC-09	B312 Series	BR-17-24	B297-24	CUSH CLP IPS 2	BVP200
BC-10	B751	BR-17-30	B297-30	CUSH CLP IPS 2 1/2	BVP250
BC-11	B751-J Series	BR-17-36	B297-36	CUSH CLP IPS 3	BVP300
BC-12	B751-J Series	BR-18-6	B293-6	CUSH CLP IPS 3 1/2	BVP350
BC-13-1/4	B303	BR-18-12	B293-12	CUSH CLP IPS 4	BVP400
BC-13-5/16	B304	BR-19-18	B293A-18	CUSH CLP IPS 5	BVP500
BC-13-3/8	B305	BR-18-24	B293-24	CUSH CLP IPS 6	BVP600
BC-13-1/2	B307	BR-19-6	B293A-6	CUSH STRIP	B1999
BC-13-5/8	B309	BR-18-12	B293-12	D-12	B12
BC-13-3/4	B321-5	BR-19-18	B293A-18	D-12 END CAP	B221
BC-14-1/4	B303	BR-19-24	B293A-24	E SAFETY END CAP	B822-A
BC-14-5/16	B304	BR-20	B439	E-12	B11
BC-14-3/8	B321-1	BR-21	B356	E-12 END CAP	B222
BC-14-1/2	B321-2	BR-22-6	B409-6	EMTC-1/2	B2001

Tolco™ to B-Line Cross Reference

Tolco Fig#	B-Line Pt. #	Tolco Fig#	B-Line Pt. #	Tolco Fig#	B-Line Pt. #
EMTC-3/4	B2002	L-23 U	B844	OD 3/4	B2027
EMTC-1	B2003	L-24 L	B503L	OD 7/8	B2008
EMTC-1 1/4	B2004	L-24 R	B503R	OD 1	B2029
EMTC-1 1/2	B2005	L-25 L	B503L	OD 1 1/8	B2030
EMTC-2	B2006	L-25	B503R	OD 1 1/4	B2031
F-09	B129	L-26 L	B236L	OD 1 3/8	B2032
F-10	B200D	L-26 R	B236R	OD 1 1/2	B2004
F-11	B201D	L-27	B357	OD 1 5/8	B2011
F-12-1/2	B202-D	L-28	B237	OD 1 3/4	B2005
F-12-5/8	B202-1D	L-29	B240-378	OD 1 7/8	B2036
F-12-3/4	B202-2D	L-30	B558	OD 2	B2037
F-13	B200	L-31 L	B235L	OD 2 1/8	B2038
F-14	B201	L-31 R	B235R	OD 2 1/4	B2039
F-15	B202	L-32	B126	OD 2 3/8	B2013
F-15	B202	L-33	B127	OD 2 1/2	B2041
F-16	B202-1	L-34	B118	OD 2 5/8	B2042
F-17	B202-2	L-35	B239	OD 2 3/4	B2043
F-18	N/C	L-36 L	B234L	OD 2 7/8	B2014
F-20	B141	L-36 R	B234R	OD 3	B2045
F-21	B342	L-37	B112	OD 3 1/8	B2046
F-22	B340	L-38	B113	OD 3 1/4	B2047
F-23	B341	L-39	B461	OD 3 3/8	B2048
F-24	B504	L-40	B533	OD 3 1/2	B2015
F-25	B133	L-41	B485	OD 3 5/8	B2050
F-26	B138	L-42 L	B134L	OD 3 3/4	B2051
F-27	B139	L-42 R	B134R	OD 3 7/8	B2052
F-28	B132	L-43	B125	OD 4	B2016
F-29	B339	L-44-12	B261-12	OD 5 1/8	B2062
F-30	B337	L-44-16	B261-16	OD 5 1/4	B2063
F-31	B136	L-44-18	B261-18	OD 5 3/8	B2064
F-32	B532	L-45-30	B162	OD 5 1/2	B2019
F-33	B142	L-45-45	B154	OD 5 5/8	B2066
F-34	B556	L-45-60	B150	OD 5 3/4	B2067
F-35	B135	L-46-30	B246	OD 5 7/8	B2068
F-36	B140	L-46-45	B248	OD 6	B2069
F-37	B143	L-46-60	B250	OD 6 1/8	B2110
F-38	B334	L-47-30	N/C	OD 6 1/4	B2111
HEX HEAD BOLTS	HHCS	L-47-45	B155	OD 6 3/8	B2112
L-08	B231	L-47-60	B159	OD 6 1/2	B2113
L-10	B101	L-48-30	N/C	OD 6 5/8	B2020
L-11	B230	L-48-45	B368	OD 6 3/4	B2115
L-12-3	B359	L-48-60	B366	OD 6 7/8	B2116
L-12-3 1/2	B360	NUT 1/4	N224WO	OD 7	B2117
L-12-4	B361	NUT 3/8	N228WO	OD 7 1/8	B2118
L-15	B372	NUT 1/2	N225WO	OD 7 1/4	B2119
L-16	B496-1	NUT 5/8	N255WO	OD 7 3/8	B2120
L-17	B496	NUT 3/4	N275WO	OD 7 1/2	B2121
L-18	B102	NUT 7/8	N278WO	OD 7 5/8	B2021
L-19	B232	OD 1/4	B2023	OD 7 3/4	B2123
L-20	B103	OD 3/8	B2024	OD 7 7/8	B2124
L-21	B371-2	OD 1/2	B2025	OD 8	B2125
L-22	B104	OD 5/8	B2026	OD 8 1/8	B2126

Tolco to B-Line Cross

Tolco™ to B-Line Cross Reference

Tolco to B-Line Cross

Tolco Fig#	B-Line Pt. #	Tolco Fig#	B-Line Pt. #	Tolco Fig#	B-Line Pt. #
OD 8 ^{1/4}	B2127	RIGID 2	B2013	TSN 3/8	TN228
OD 8 ^{3/8}	B2128	RIGID 2 ^{1/2}	B2014	TSN 1/2	TN225
OD 8 ^{1/2}	B2129	RIGID 3	B2015	U-10	B107
OD 8 ^{5/8}	B2022	RIGID 3 ^{1/2}	B2016	U-11	B116-52
OD 8 ^{3/4}	B2133	RIGID 4	B2017	U-12	B116-12
OD 8 ^{7/8}	B2134	RIGID 5	B2019	U-13-7 ^{1/4}	B333-1
OD 9	B2135	RIGID 6	B2120	U-13-8 ^{1/2}	B333-2
OD 9 ^{1/2}	B2139	RIGID 8	B2122	U-13-10 ^{3/8}	B333-3
OD 9 ^{5/8}	B2140	ROL-10	B377	U-16	B107-22A
OD 10	B2143	ROL-11	B376	U-18	B398-1
OD 10 ^{3/4}	B2130	ROL-12*	B218	U-22	B169, B170
OD 11	B2151	ROL-13	B219 Series	U-24	B167, B172
OD 11 ^{5/8}	B2156	ROL-14	B379	U-26	B173
OD 12	B2159	ROL-15	B479	U-29	B400-1
OD 12 ^{3/4}	B2132	ROL-16	B3126 Series	U-30	B400-3
OD CP 3/8	B2024DCU	SPRA 1/4	N224	U-31	B425
OD CP 1/2	B2025DCU	SPRA 3/8	N228	U-32	B519
OD CP 5/8	B2026DCU	SPRA 1/2	N225	U-33	B581
OD CP 3/4	B2027DCU	SPRA 5/8	N255	U-34	N/C
OD CP 7/8	B2008DCU	SPRA 3/4	N275	UNIV-1/2	B2208
OD CP 1 ^{1/8}	B2030DCU	SPRA 7/8	N278	UNIV-3/4	B2209
OD CP 1 ^{3/8}	B2032DCU	SPRC 1/4	N524	UNIV-1	B2210
OD CP 1 ^{5/8}	B2011DCU	SPRC 3/8	N528	UNIV-1 ^{1/4}	B2211
OD CP 2 ^{1/8}	B2038DCU	SPRC 1/2	N525	UNIV-1 ^{1/2}	B2212
OD CP 2 ^{5/8}	B2042DCU	SPRC 5/8	N555	UNIV-2	B2213
OD CP 3 ^{1/8}	B2046DCU	SPRC 3/4	N575	W-10 L	B267L
OD CP 3 ^{5/8}	B2050DCU	SPRD 1/4	N724	W-10 R	B267R
OD CP 4 ^{1/8}	B2054DCU	SPRD 3/8	N728	W-11 L	B269L
OD CP 5 ^{1/8}	B2062DCU	SPRD 1/2	N725	W-11 R	B269R
OD CP 6 ^{1/8}	B2110DCU	SPRD 5/8	N755	W-12	B119
P-09	B280FL	SPRD 3/4	N775	W-13	B120
P-10	B279	SPRM 1/4	SN224	W-14	B121
P-10 F	B279FL	SPRM 3/8	SN228	W-16	B271
P-10 SQ	B279SQ	SPRM 1/2	SN225	W-17	B272
P-11	B280	SPRM 5/8	SN255	W-18	B273
P-11 F	B280FL	SWF 3/8	B446A-3/8	W-19	B122
P-11 SQ	B280SQ	SWF 1/2	B446A-1/2	W-20	B124
P-12	B281A	SWF 5/8	B446A-5/8	W-21	B123
P-12 F	B281AFL	SWF 3/4	B446A-3/4	W-22 L	B274L
P-12 SQ	B281ASQ	SWFF 3/8	B446C-3/8	W-22 R	B274R
P-13	B281	SWFF 1/2	B446C-1/2	W-23	B276
P-13 F	B281FL	SWFF 5/8	B446C-5/8	W-24	B495
P-13 SQ	B281SQ	SWFF 3/4	B446C-3/4	W-25	B362
P-14	B585	SWM 3/8	B446B-3/8	Z-10	B105
P-15	B278	SWM 1/2	B446B-1/2	Z-15	B108
PIPE PIER	DURA-BLOKS	SWM 5/8	B446B-5/8	Z-17	B586
RIGID 3/8	B2001	SWM 3/4	B446B-3/4	Z-25	B515
RIGID 1/2	B2008	SWMF 3/8	B446-3/8		
RIGID 3/4	B2009	SWMF 1/2	B446-1/2		
RIGID 1	B2010	SWMF 5/8	B446-5/8		
RIGID 1 ^{1/4}	B2011	SWMF 3/4	B446-3/4		
RIGID 1 ^{1/2}	B2012	TSN 1/4	TN224		

65XT-3/8 114	B22A3 21	B24KO6 41	B42S 40
69 115	B22A4 21	B24KO6AL 178	B42S58 42
69R 115	B22AAL 177	B24M 42	B42SH 40
75 55	B22AD3 21	B24S 40	B42SHSS4 180
98 57	B22AL 177	B24S58 42	B42SS4 180
98B 57	B22B 21	B24SH 40	B44M 42
ACPD Series 220	B22B3 21	B24SHAL 178	B52 32,33
ACPW Series 220	B22C 21	B24SHSS4 180	B52A 32,33
ACS Series 221	B22C3 21	B24SHSS6 180	B52B3 32
ADH Series 219	B22D 21	B24SS4 180	B52B4 32
AHHK-1/4 227	B22D3 21	B24SS6 180	B52H17/8 40
AHHK-3/8 227	B22E 21	B26 26,27	B52H25 42
APC Series 220	B22E3 21	B26A 26,27	B52-I Series 216
ARC Series 219	B22H17/8 40	B26B 26	B52-IFS 218
ARS Series 219	B22H17/8AL 178	B26C 26	B52KO6 41
ASA Series 221	B22H17/8SS4 180	B26H17/8 40	B52M 42
ATM-37 221	B22H25 42	B26H25 42	B52S 40
ATR 58	B22-I Series 214	B26KO6 41	B52S58 42
AWA Series 219	B22-IFS 218	B26S 40	B52SH 40
AWS-CH 221	B22KO6 41	B26S58 42	B52SHA 41
AWS-OH 221	B22KO6AL 178	B26SH 40	B52SHSS4 180
AWS-PH 221	B22LPL 21	B32 28,29	B52SHSS6 180
B11 16,17	B22M 42	B32A 28,29	B52SS4 180
B11A 16,17	B22PL 21	B32B 28	B52SS6 180
B11AL 177	B22S 40	B32C 28	B54 34,35
B11B 17	B22S58 42	B32H17/8 40	B54A 34,35
B11H17/8 40	B22SH 40	B32H17/8SS4 180	B54AAL 177
B11KO6 41	B22SHA 41	B32H25 42	B54AL 177
B11S 40	B22SHAL 178	B32-I Series 215	B54B3 34
B11S58 42	B22SHSS4 180	B32-IFS 218	B54B4 34
B11SH 40	B22SHSS6 180	B32KO6 41	B54H17/8 40
B12 18,19	B22SS4 180	B32M 42	B54H17/8AL 178
B12A 18,19	B22SS6 180	B32S 40	B54H17/8SS4 180
B12AL 177	B22TH 38,39,41	B32S58 42	B54H17/8SS6 180
B12B 18	B22X 20-23	B32SH 40	B54H25 42
B12H17/8 40	B24 24,25	B32SHSS4 180	B54KO6 41
B12H17/8AL 178	B24A 24,25	B32SS4 180	B54KO6AL 178
B12KO6 41	B24AL 177	B42 30,31	B54M 42
B12KO6AL 178	B24B 24	B42A 30,31	B54S 40
B12S 40	B24C 24	B42B 30	B54S58 42
B12S58 42	B24H17/8 40	B42H17/8 40	B54SH 40
B12SH 40	B24H17/8AL 178	B42H17/8SS4 180	B54SHA 41
B12SHAL 178	B24H17/8SS4 180	B42H25 42	B54SHAL 178
B22 20-23	B24H17/8SS6 180	B42KO6 41	B54SHSS4 180
B22A 20,22,23	B24H25 42	B42M 42	B54SHSS6 180

B54SS4	180	B122	95	B171	86	B198A-12	102
B54SS6	180	B123	95	B172	86	B200	73
B56	36,37	B124	95	B172-12	86	B200D	73
B56A	36,37	B125	79	B172-22A	86	B201	73
B56B3	36	B126	80	B173	89	B201D	73
B56B4	36	B127	80	B174SHL	101	B202	73
B56H1 ⁷ / ₈	40	B129	73	B174SHR	101	B202-1	73
B56H25	42	B132	74	B175SHL	101	B202-1D	73
B56KO6	41	B133	74	B175SHR	101	B202-2	73
B56S	40	B134L	79	B176SHL	101	B202-2D	73
B56S58	42	B134R	79	B176SHR	101	B202D	73
B56SH	40	B135	74	B177SHL	101	B203	110,167
B62	201	B136	75	B177SHR	101	B204	110,167
B62A	201	B137	75	B178SHL	101	B205	110,167,218
B72	202	B138	74	B178SHR	101	B206	110,167,218
B72A	202	B139	74	B179SHL	101	B210	116
B101	76	B140	74	B179SHR	101	B210A	116
B102	77	B141	73	B180SHL	101	B211	122
B103	77	B142	74	B180SHR	101	B212- ¹ / ₄	122
B104	77	B143	74	B181SHL	101	B212- ³ / ₈	122
B104SH	81	B147	82	B181SHR	101	B213	122
B105	91	B148	82	B182SHL	101	B214L	106
B106-12	91	B149	82	B182SHR	101	B214R	106
B106-32	91	B150	82	B183SHL	101	B215S	165
B106-42	91	B151	82	B183SHR	101	B216S	165
B106-52	91	B152	82	B184SHL	101	B217-20	167
B107	87	B154	82	B184SHR	101	B217-24	167
B107-22A	87	B155	83	B185SHL	101	B217AL	177
B107S	88,125	B156	83	B185SHR	101	B217FFAL	177
B108	91	B157	83	B186SHL	101	B217P ...	167,177,199
B109S	81	B158	83	B186SHR	101	B218	147
B110	91	B159	83	B187	99	B219 Series ..	148,149
B111	92	B160	83	B188	99	B220	110,167,218
B112	81	B161	83	B189	99	B221	110,167
B113	81	B162	82	B190	99	B222	110,167
B115	77	B163	82	B191-18	99	B223	110,167
B116-12	87	B164	82	B191-24	100	B230	76
B116-32	87	B165	82	B192	100	B231	76
B116-32A	87	B166 Series	171	B194	102	B232	77
B116-42	87	B166-46 Series ...	171	B195	103	B234L	79
B116-52	87	B166CL	171	B196-18	102	B234R	79
B118	79	B167	86	B196-24	102	B235L	78
B119	94	B168	86	B198-6	102	B235R	78
B120	95	B169	86	B198-12	102	B236L	78
B121	95	B170	86	B198A-6	102	B236R	78

B237	78	B281M	98	B333-3	89	B386 Series	144
B238L	78	B281MSQ	98	B334	75	B387 Series	92
B238R	78	B281SQ	98	B335	83	B390BX	166
B239	78	B283	110,167	B335-1	83	B390S	166
B241S	165	B284	110,167	B335-2 Series	83	B392-11 Series	168
B243	82	B285	110,167	B335V Series	83	B392-12 Series	168
B244	82	B286	110,167	B337	75	B392-22 Series	168
B245	82	B287	110	B339	75	B392-32 Series	168
B246	82	B288	110	B340	73	B393-1	171
B247	82	B289-12	100	B341	73	B394 Series	144
B248	82	B289-14	100	B342	73	B398-1	90
B249	82	B290	100	B346L	95	B400	90
B250	82	B291	100	B346R	95	B400-1	90
B251	82	B292	101	B349	108	B400-2	90
B252	82	B293 Series	102	B350	108	B400-3	90
B253	82	B293A Series	102	B351L Series	113	B400-4	90
B261 Series	85	B293PL	103	B355	122	B405	89,123
B266	88	B297 Series	101	B356	146	B405A	123
B267L	94	B300	98	B357	78	B407 Series	92
B267R	94	B303	117	B358 Series	89	B408 Series	89
B268L	94	B304	117	B359	76	B408SLBVNS	111
B268R	94	B305	117	B360	76	B409 Series	101
B269L	94	B306	117	B361	77	B410-11	93
B269R	94	B307	117	B362	96	B410-12	93
B270L	94	B308	117	B363	83	B410-22	93
B270R	94	B309	117	B364	83	B410-32	93
B271	95	B312 Series	117	B365	83	B410-52	93
B272	95	B314	121	B366	83	B411 Series	107
B273	95	B318	123	B367	83	B412	88
B274L	96	B319	123	B368	83	B415	90
B274R	96	B320	123	B369	83	B420-378	76
B276	95	B321 Series	117	B370	103	B420-578	76
B277	96	B322	82	B371	80	B420-778	76
B278	98	B323	82	B371-2	81	B420-978	76
B279	97	B324	82	B372	80	B422 Series	125,140
B279FL	97	B325	82	B374	77	B425	88
B279SQ	97	B326	82	B376	109	B427	123
B280	97	B327	82	B377	109	B428	93
B280FL	97	B328	82	B379	150	B432	75
B280SQ	97	B329	82	B380 Series	218	B435	122
B281	98	B330	82	B381	107	B436	166
B281A	97	B331	82	B382	107	B436S	166
B281AFL	97	B332	82	B383	107	B437 Series	139
B281ASQ	97	B333-1	89	B384	107	B438	107
B281FL	98	B333-2	89	B385	107	B439	107

B440	103	B500 Series ...	52,120	B591 Series	145	B756- ³ / ₈	119
B441-22 Series ...	121	B501 Series	52	B593	125	B760-22 Series ...	124
B441-22A Series .	121	B503L	80	B594	88	B760-22A Series .	124
B441Z-22	121	B503R	80	B595	89	B761-22 Series ...	124
B441Z-22A	121	B504	74	B596	88	B761-22A Series .	124
B444 Series	116	B514L	106	B598-62	210	B766 Series	170
B446 Series ...	54,172	B514R	106	B600-62	204	B767 Series	170
B446A Series ..	54,172	B515	93	B601-62	208	B768 Series	170
B446B Series ..	54,172	B516	167	B602-A	123	B769 Series	170
B446C Series .	54,172	B516S	167	B602-B	123	B802D Series	104
B447	168	B518 Series	169	B602-C	123	B809B Series	105
B447A	168	B519	88	B613	108,125	B810 Series	104
B449-4	103	B521	81	B613A	108,125	B811 Series	105
B449-8	103	B522	82	B614	108,125	B812 Series	105
B449-12	103	B526	91	B616 Series	164	B816	104
B449-18	103	B527	87	B616-22A Series .	164	B822	110
B450 Series	86	B528	73	B616S Series	164	B822A	110
B451-1	89	B529	77	B616S-22A Series	165	B823-22	111
B451-2	89	B532	75	B616TG- ⁹ / ₁₆	165	B823-22A	111
B451-3	89	B533	80	B617	55,172	B823-42	111
B460 Series	166	B534	92	B619	171	B823-52	111
B461	81	B535	92	B631 Series	85	B825-22	111
B464 Series	166	B536	90	B632 Series	85	B825-52	111
B465	166	B538	92	B633 Series	84	B844	79
B466S	171	B539	92	B634	84	B844W	79
B466W	171	B541	99	B635	84	B852	110
B472	106	B556	75	B650 Series	84	B852S Series	104
B473	106	B557	73	B655 Series	58	B888W	79
B474	106	B558	77	B656 Series	58	B1508	132
B475	106	B560	108	B663	80	B1508S	132
B477	109	B562	108	B670 Series	140	B1512	132
B477H	109	B568	75	B671 Series	140	B1512S	132
B477HP	109	B570	98	B700 Series	120	B1516	132
B477P	109	B570A	98	B701 Series	118	B1516S	132
B478	109	B571	96	B702	119	B1520	132
B478H	109	B578	88	B705 Series	119	B1520S	132
B478HP	109	B580	93	B718 Series	169	B1524S	132
B478P	109	B581	88	B719AL	169	B1532S	132
B479	151	B585	98	B750 Series	120	B1534S	132
B485	80	B586	91	B751	118	B1540S	132
B488	82	B587 Series	107	B751-J Series ...	118	B1548S	132
B494 Series	101	B588	87	B752	118	B1556S	132
B495	96	B589	171	B753 Series	118	B1564S	132
B496	81	B589-62	207	B755	119	B1999	137
B496-1	81	B590	172	B755- ³ / ₈ -J Series .	119		

B2000 128	B2019AL 178	B2062 131	B2128 131
B2001 128	B2019SS4 181	B2062DCU 129	B2129 131
B2001AL 178	B2020 128,131	B2063 131	B2130 128,131
B2001SS4 181	B2020AL 178	B2064 131	B2132 128,131
B2002 128	B2020SS4 181	B2066 131	B2207 127
B2003 128	B2021 128,131	B2067 131	B2208 127
B2004 128,130	B2022 128,131	B2068 131	B2209 127
B2005 128,130	B2023 130	B2069 131	B2210 127
B2006 128	B2024 130	B2070 139	B2211 127
B2008 128,130	B2024DCU 129	B2071 139	B2212 127
B2008AL 178	B2025 130	B2072 139	B2213 127
B2008DCU 129	B2025DCU 129	B2073 139	B2301 Series 141
B2008SS4 181	B2026 130	B2074 139	B2302 Series 141
B2009 128	B2026DCU 129	B2075 139	B2308 211
B2009AL 178	B2027 130	B2076 139	B2309 211
B2009SS4 181	B2027DCU 129	B2077 139	B2310 211
B2010 128	B2030 130	B2078 139	B2311 211
B2010AL 178	B2030DCU 129	B2079 139	B2312 211
B2010SS4 181	B2031 130	B2080 139	B2313 211
B2011 128,130	B2032 130	B2084 141	B2314 211
B2011AL 178	B2032DCU 129	B2085 141	B2315 211
B2011DCU 129	B2037 130	B2086 141	B2350 211
B2011SS4 181	B2038 130	B2087 141	B2351 211
B2012 128	B2038DCU 129	B2088 141	B2352 211
B2012AL 178	B2039 130	B2089 141	B2353 211
B2012SS4 181	B2041 130	B2090 141	B2354 211
B2013 128,130	B2042 130	B2091 141	B2355 211
B2013AL 178	B2042DCU 129	B2110 131	B2400 Series 138
B2013SS4 181	B2043 130	B2110DCU 129	B2417 Series 139
B2014 128,130	B2045 130	B2111 131	B2500 217
B2014AL 178	B2046 130	B2112 131	B2501 Series 217
B2014SS4 181	B2046DCU 129	B2113 131	B2503 217
B2015 128,130	B2047 130	B2115 131	B2505 217
B2015AL 178	B2048 130	B2116 131	B2506 217
B2015SS4 181	B2050 130	B2117 131	B2507 217
B2016 128,130	B2050DCU 129	B2118 131	B2508 217
B2016AL 178	B2051 130	B2119 131	B2601 133
B2016SS4 181	B2052 130	B2120 131	B2602 133
B2017 128,130	B2054 130	B2121 131	B2603 133
B2017AL 178	B2054DCU 129	B2123 131	B2608 133
B2017SS4 181	B2055 130	B2124 131	B2609 133
B2018 128,131	B2056 130	B2125 131	B2610 133
B2018AL 178	B2058 130	B2126 131	B3033 Series 114
B2018SS4 181	B2059 131	B2126DCU 129	B3034 Series 114
B2019 128,131	B2060 131	B2127 131	B3036L Series 113

B3037Z 115	B4035D 174	B6104 206	B6169 208
B3322 110,218	B4035E 174	B6105 210	B6170 209
B3332 110,218	B4035F 174	B6107 209	B6171 209
B3342 110,218	B4037B 174	B6107-62A 209	B6172 209
B3352 110,218	B4050 174	B6108 210	B6173 210
B3362 Series 113	B4051 174	B6110 210	B6202 203
B3363 Series 113	B4060 173	B6112 207	B6205 211
B3364 Series 113	B4061 173	B6118 207	B6211 211
B3365 Series 113	B4062 173	B6126 207	B6230 205
B3367 Series 115	B4063 173	B6127 207	B6232 206
B3367S-1 Series 140	B4064 173	B6129 203	B6234L 207
B3367S-2 Series 140	B4065 173	B6132 205	B6234R 207
B3373 Series 142	B4066 173	B6133 205	B6239 206
B3690 Series 143	B4067 173	B6134L 207	B6337 205
B3690F Series 143	B4068 173	B6134R 207	B6340 203
B4000 175	B4069 173	B6135 205	B6341 204
B4001 175	B4070 173	B6136 205	B6357 206
B4002 175	B4071 173	B6138 204	B6374 206
B4003 175	B4072 173	B6139 204	B6409 Series 211
B4004 175	B4073 173	B6140 204	B6504 204
B4005 175	B4074 173	B6141 204	B6526 210
B4006 175	B4075 173	B6142 205	B6532 205
B4007 175	B4076 173	B6143 204	B6533 207
B4008 175	B4077 173	B6144L 206	B6557 204
B4009 175	B4078 173	B6144R 206	B6558 206
B4010 175	B4079 173	B6147 208	B6571 210
B4011 175	B4080 173	B6148 208	B6594 209
B4012 175	B4081 173	B6149 208	B7105 210
B4013 175	B4082 173	B6150 208	B7116 209
B4014 175	B4083 173	B6151 208	B7205 211
B4015 175	B4084 173	B6152 208	BC442 116
B4016 175	B4085 173	B6154 208	BD40 218
B4017 175	B4086 173	B6155 208	BE-5-8 218
B4033A 175	B4087 173	B6156 208	BE-9-12 218
B4033B 175	B4088 173	B6157 208	BFP22 184,185
B4033C 175	B4089 173	B6158 208	BFP22A 184,185
B4033D 175	B4090 173	B6159 208	BFP22H ^{17/8} 184
B4033E 175	B4091 173	B6160 208	BFP22I 188
B4033F 175	B4092 173	B6161 208	BFP22SH 184
B4033G 175	B4093 173	B6162 208	BFP42 186,187
B4033H 175	B4094 174	B6163 208	BFP42A 186,187
B4033I 175	B4095 174	B6164 208	BFP42H ^{17/8} 186
B4035A 174	B6101 205	B6165 208	BFP42SH 186
B4035B 174	B6102 206	B6167 209	BFP409 Series ... 194
B4035C 174	B6103 206	B6168 209	BFP494 Series ... 194

BFP2400-2 192	BFV337 197	BAK25-063 Series . 70	BMM-3S 203
BFP2400-3 192	BFV340 195	BAK25-063K Series . 70	BMM-4 203
BFP2400-4 192	BFV341 196	BKB25-063 Series . 68	BMM-4L 203
BFP2400-6 192	BFV342 196	BKB25-06K3 Series . 69	BMM-4S 203
BFP3104-8 193	BFV371-2G 198	BKB38-094 Series . 68	BMM-5 203
BFP3104-10 193	BFV409 Series 194	BKB38-094K Series . 69	BMM-5L 203
BFP3104-12 193	BFV494 Series 194	BKC100 59	BMM-5S 203
BFV22 184,185	BFV501 Series 188	BKC200 59	BMM-6 203
BFV22A 184,185	BFV532 197	BKCC 60	BMM-6L 203
BFV22H1 ^{7/8} 184	BFV557 195	BKF100-4 61	BMM-6S 203
BFV22I 188	BFV558 198	BKF100-6 61	BMS-6 46
BFV22SH 184	BFV650 199	BKH-094 Series ... 64	BMS-6L 47
BFV42 186,187	BFV655 Series 190	BKH-094K Series .. 64	BMS-6M 47
BFV42A 186,187	BFV751-1/2 192	BKL-063 Series 63	BMS-6S 47
BFV42H1 ^{7/8} 186	BFV751- ^{3/8} 192	BKL-063K Series .. 63	BMS-8 46
BFV42SH 186	BFV751- ^{5/8} 192	BKL-094 Series 63	BMS-8L 47
BFV100 191	BFV751J-1/2 192	BKL-094K Series .. 63	BMS-8M 47
BFV101 198	BFV751J- ^{3/8} 192	BKP10063 60	BMS-8S 47
BFV103 198	BFV751J- ^{5/8} 192	BKP10094 60	BMS-10 46
BFV104 198	BFV755-1/2 193	BKP20125 60	BMS-10L 47
BFV118 198	BFV755- ^{3/8} 193	BKP20188 60	BMS-10M 47
BFV129 185	BFV2008 191	BKT-063 Series 66	BMS-10S 47
BFV132 196	BFV2009 191	BKT-063K Series .. 66	BMS-12 46
BFV133 196	BFV2010 191	BKW063 59	BMS-12M 47
BFV135 197	BFV2011 191	BKW094 59	BMS-12S 47
BFV136 197	BFV2012 191	BKW125 59	BMS-D-12 46
BFV140 196	BFV2013 191	BKW188 59	BMS-D-12L 47
BFV141 195	BFV2014 191	BKYH18-094 64	BMS-D-12M 47
BFV142 197	BFV2015 191	BKYH18-094 Series . 65	BMT-6 48
BFV143 196	BFV2016 191	BKYH18-094K Series 65	BMT-8 48
BFV200 191	BFV2017 191	BKYH30-094 64	BMT-10 48
BFV201 195	BFV3104 -1 thru 6 193	BKYH30-094 Series . 65	BMT-12 48
BFV202 195	BFV3104-8 193	BKYH30-094K Series 65	BMT-D-12 48
BFV-223 189	BFV3104-10 193	BKYT12-063 66	BP081SS 133
BFV-223WO 189	BFV3104-12 193	BKYT12-063 Series . 67	BP110SS 133
BFV-224 189	BFVATR Series ... 190	BKYT12-063K Series 67	BP135SS 133
BFV-224WO 189	BFVATRHN Series 190	BKYT18-063 66	BP175SS 133
BFV-225 189	BFVFW Series 190	BKYT18-063 Series . 67	BP205SS 133
BFV-225WO 189	BFVHHCS Series . 189	BKYT18-063K Series 67	BP250SS 133
BFV-228 189	BFVHN Series 189	BKYT30-063 66	BP300SS 133
BFV-228WO 189	BFVSL Series 190	BKYT30-063 Series . 67	BP325SS 133
BFV280SQ 199	BHR1225ZN 58	BKYT30-063K Series 67	BP375SS 133
BFV281SQ 199	BHR1238ZN 58	BL1400 Series 142	BP425SS 133
BFV300 191	BHR1250ZN 58	BMM-3 203	BP475SS 133
BFV334 197	BHR1262ZN 58	BMM-3L 203	BPC Series 127

Index

BTS22TH	38,39	LW Series	56	N575	47	SC228	57
BVP Series	135	MSQN Series	55	N575WO	46	SC-UB	57
BVS-12	137	N221	47	N621	203	SFHMS Series	53
BVS-120	137	N221WO	46	N621WO	203	SHHMS Series	53
BVT Series	134	N222	47	N622	203	SLWN1/4	56
CLDP10	155	N222WO	46	N622WO	203	SLWN1/2	56
CNPSS Series	53	N223	47	N624	203	SLWN3/8	56
DB_DS Series	156,157	N223WO	46	N624WO	203	SLWN5/8	56
DB5	153	N224	47	N627	203	SLWNM6	56
DB10	153	N224SS6	179,181	N627WO	203	SLWNM8	56
DB10-28	154	N224WO	46	N721	47	SLWNM10	56
DB10-36	154	N224WOSS6	178,181	N722	47	SLWNM12	56
DB10-42	154	N225	47	N723	47	SN224 Series	49
DB10-50	154	N225SS6	179,181	N724	47	SN224WO Series	48
DB10-60	154	N225WO	46	N724SS6	179	SN225 Series	49
DB20	153	N225WOSS6	179,181	N725	47	SN225WO Series	48
DB30	153	N226	47	N725SS6	179	SN228 Series	49
DB40	153	N226WO	46	N726	47	SN228WO Series	48
DB48	153	N227	47	N727	47	SN524 Series	49
DB610	153	N227WO	46	N728	47	SN525 Series	49
DB620	153	N228	47	N728SS6	179	SN525WO Series	48
DB630	153	N228SS6	179,181	N755	47	SN528 Series	49
DB640	153	N228WO	46	N775	47	SN724 Series	49
DB648	153	N228WOSS6	179,181	N778	47	SN725 Series	49
DBE10-8	155	N255	47	N2500 Series	217	SN728 Series	49
DBE10-12	155	N255WO	46	N7221	203	SQN Series	55
DBE10-16	155	N275	47	N7222	203	SRHMS Series	53
DBM	153	N275WO	46	N7224	203	STN224 Series	48
DBM-__ Series	154	N278	47	N7227	203	STN225 Series	48
DBM-__CT Series	154	N278WO	46	NW524	49	STN228 Series	48
DBP	153	N521	47	NW525	49	STN525 Series	48
DBR10-12	155	N522	47	NW528	49	TN221	48
DBR2-31/2	158	N523	47	NWM6	49	TN222	48
DBR4-6	158	N524	47	NWM8	49	TN223	48
DBR8-10	158	N524SS6	179,181	NWM10	49	TN224	48
DBR12-14	158	N525	47	NWM12	49	TN225	48
DBR16-20	158	N525SS6	179,181	SA101	227	TN226	48
DCN ³ / ₈	52	N525WO	46	SA102	227	TN227	48
FFW Series	56	N525WOSS6	179	SA110	227	TN228	48
FW Series	56	N526	47	SA131	227	TN255	48
HHCS Series	53	N527	47	SA154	227	TN525	48
HN Series	55	N528	47	SA155	227		
IPH Series	136	N528SS6	179,181	SA158	223-226		
IPH18230	136	N555	47	SA276	223-226		
ISO	137	N555WO	46	SA318	223-226		

B-Line reserves the right to make changes to the specifications, materials, equipment, prices, or the availability of products at any time without prior notice. While every effort has been made to assure the accuracy of information contained in this catalog at the time of publication, we cannot accept responsibility for inaccuracies resulting from undetected errors or omissions.

U.S. Customer Service Center is staffed Monday through Friday
from 7 a.m. to 5:00 p.m. Central Standard Time.

**Eaton's B-Line Business
United States**
509 West Monroe Street
Highland, IL 62249
United States
Phone: (800) 851-7415
www.cooperbline.com/contactus

**Eaton's B-Line Business
United Kingdom**
Walrow Industrial Estate
Somerset, TA9 4AQ
United Kingdom
Phone: (44) 1278 772600
www.cooperbline.com/contactuk

**Eaton's B-Line Business
Canada**
5925 McLaughlin Road
Mississauga, ON L5R 1B8
Canada
Phone: (800) 569-3660
www.cooperbline.com/contactca

**Eaton's B-Line Business
Middle East**
PO Box 70160 - Al Khobar - 31952
Kingdom of Saudi Arabia
Phone: 00966 3 812 2236
www.cooperbline.com/contactme

Eaton
1000 Eaton Boulevard
Cleveland, OH 44122
United States
Eaton.com

B-Line Business
509 West Monroe Street
Highland, IL 62249
Phone: 800-851-7415
Fax: 618-654-1917
www.bline.com

© 2013 Eaton
All Rights Reserved
Printed in USA
Publication No. SS-13
September 2013 35M

Eaton is a registered trademark
All other trademarks are property
of their respective owners.