



"Dedicated To Providing Customers With Value Added Fastening Solutions"



Welcome To Advanced Cable Ties, Inc.



Founded in 1994, Advanced Cable Ties, Inc. (ACT) is a full-line manufacturer of cable ties and accessories used in industrial/fastener, electronic, electrical, HVAC, and a variety of other specialty applications.

Superior Quality

ACT has been ISO-9002 registered since 1999 and recently acquired an upgrade to ISO-9001:2000 by the Quality Management Institute. ACT is a fully automated state-of-the-art molding facility. We manufacture superior cable ties that combine the lowest insertion force with the highest tensile strength. All ACT products meet the UL (1565), and CSA (C22.2) safety standards in both the U.S. and Canada, as well as U.S. Military (Mil-S-23190) standards.

Innovative Design

The design of the pawl (locking mechanism) makes ACT cable ties superior in strength and allows our products to exceed the required tensile strengths used in industry standards. ACT's mounting pad incorporates a unique no-slip tab that holds cable ties in place during installation. ACT's Cobra cable tie incorporates a grooved head design to flex around smaller bundles while providing a low profile to eliminate snags and abrasions.

Commitment to Customer Satisfaction

We maintain our industry leadership by our total commitment to customer satisfaction. We build strong partnerships to promote productivity, innovation and long-term profitability for our customers. ACT sells only through authorized distributors and ships from five strategically-located warehouses to accommodate our customers' tight delivery requirements. ACT also provides knowledgeable local manufacturers' representatives to assist you.



Table Of Contents

Miniature Cable Ties	1
Intermediate & Standard Cable Ties	2
Heavy Duty, Extra Heavy Duty, & 250 lb. Cable Ties	3
Color & Fluorescent Cable Ties	4-5
ACTPACs	6-7
ACTKITS	8
Tote Box Cable Ties	8
Cobra Cable Ties	9
Push Mount Cable Ties	9
Mounting Hole Cable Ties	10
Screw Mounts	10
Mounting Pads	11
Low Profile Screw Mounts	11
Stainless Steel Cable Ties	12
Halar & Tefzel Cable Ties	12
Beaded Cable Ties	13
Releasable Cable Ties	13
Identification and Flag Cable Ties	14
Tension Tools	14
Cloth Wire Marker Booklets	15
0-9 Mini Dispensers & Write-Wrap Dispensers	15
Light Duty Nylon Cable Clamps	16
Heavy Duty Nylon Cable Clamps	17
Split Loom	18
Cable Wrap	19
Vinyl Insulated Ring Terminals	20
Vinyl Insulated Spade Terminals	21
Quick Splicers	21
Vinyl Insulated Butt Connectors	21
Fully Insulated Male & Female Disconnects	22
Vinyl Insulated Male & Female Disconnects	22
Vinyl Insulated Piggyback Disconnects	23
Vinyl Insulated Male Snap Plugs	23
Nylon Insulated Female Snap Plugs	23
Nylon Pigtails - Seamless	23
Heat Shrink Butt Connectors, Ring Terminals, & Spade Terminals	24
Heat Shrink Fully Insulated Female & Male Disconnects	25
Heat Shrink Tubing - Adhesive Lined	25
Crimp Tool	25
ACTCAPs	26
Part Number Cross Reference Charts	27-28
Conversion Chart	29
Mil-Spec Cable Tie Reference Chart	30
UL, CSA, and CAGE Code References	30
Cable Tie Operating Characteristics Reference Chart	30

Reading ACT Part Numbers

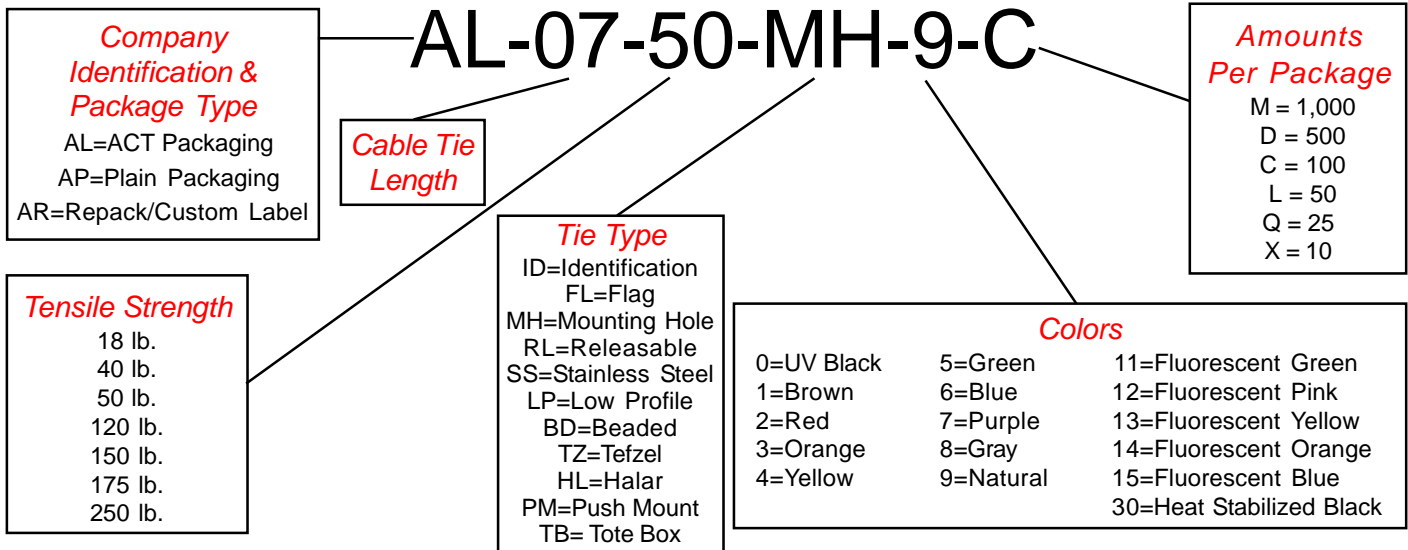

ORDER POLICY

- **Products Supplied and Sold Strictly to Approved ACT Distributors Only**
- **All Payments in U.S. Currency**
- **Terms: Net 30 days**
- **All Products are 100% Guaranteed**
- **Minimum order: \$100.00**
- **Line items will be increased or decreased by 10% to meet full case quantities**
- **UL, CSA and Mil-Spec markings available only on ACT labeled and custom labeled product**
- **Repack minimum order: \$100.00 and full case quantities per line item**
- **Allow 2-3 weeks for repacks, custom labels, tote box ties, heat stabilized ties and colored ties**
- **FOB: Free freight applies to any standard ground shipment from Massachusetts Warehouse to one location within the continental U.S. for any single release purchase order in excess of \$2,000.00**
- **For Non-Standard Product Documentation (Chemical & Physical Report, PPAP, Etc.) a \$75.00 fee will be applied per part number**
- **Prices are subject to change without notice**
- **All International Customers are responsible for GST (Goods and Service Tax), all Taxes and Duties, Tariffs and Brokerage Fees. Customer is to specify Brokerage Firm. UPS (United Parcel Service) Brokerage Service will be utilized on UPS shipments unless otherwise specified**

RETURN POLICY

- **Returns accepted only with written ACT Return Materials Authorization (RMA) from the manufacturing facility**
- **All returns are subject to a 15% re-stocking fee**
- **Requests to return material must be initiated within 90 days from the date of the original purchase and product must be returned within 90 days after request is initiated**
- **No Returns accepted on Special Orders, Special Packaging, and Custom Label**



Tel: 800-861-7228 - email: sales@advancedcableties.com
Fax: 978-630-3999 - Web: www.advancedcableties.com

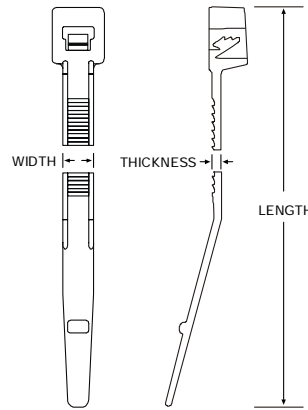
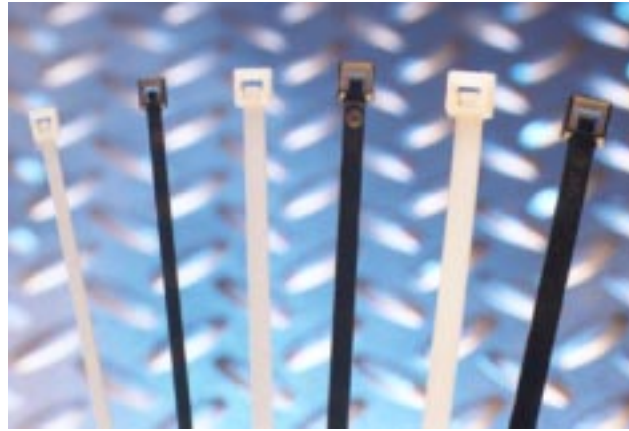

Miniature (18 lb) Natural, UV Black & Heat Stabilized Black

Per Bag	ACT Part Number	Color & Material	Length Inch/mm	Width Inch/mm	Thickness Inch/mm	Tie Tensile	Bundle Diameter	Per Case	Mil-Spec Reference
1,000	AL-04-18-9-M	Natural	4.0/101.6	.094/2.387	.042/1.066	18 lb.	1/16 - 7/8	25,000	MS3367-4-9
100	AL-04-18-9-C	Nylon						10,000	
1,000	AL-04-18-0-M	UV Black						25,000	MS3367-4-0
100	AL-04-18-0-C	Nylon						10,000	
1,000	AL-04-18-30-M	Heat Stabilized						25,000	
100	AL-04-18-30-C	Black Nylon						10,000	
1,000	AL-06-18-9-M	Natural	6.1/154.9	.094/2.387	.042/1.066	18 lb.	1/16 - 1 1/2	20,000	
100	AL-06-18-9-C	Nylon							
1,000	AL-06-18-0-M	UV Black							
100	AL-06-18-0-C	Nylon							
1,000	AL-06-18-30-M	Heat Stabilized							
100	AL-06-18-30-C	Black Nylon							
1,000	AL-08-18-9-M	Natural	8.1/205.7	.094/2.387	.042/1.066	18 lb.	1/16 - 2 3/16	20,000	
100	AL-08-18-9-C	Nylon							
1,000	AL-08-18-0-M	UV Black							
100	AL-08-18-0-C	Nylon							
1,000	AL-08-18-30-M	Heat Stabilized							
100	AL-08-18-30-C	Black Nylon							

* Tolerance: .xxx = +/- .005, .xx = +/- .015, Fraction = +/- 1/32"

* 2 Week Delivery Time For Heat Stabilized Ties

* 4", 6" & 8" UL Recognized / CSA Approved



Tel: 800-861-7228 - email: sales@advancedcableties.com
 Fax: 978-630-3999 - Web: www.advancedcableties.com

Intermediate (40 lb) Natural, UV Black & Heat Stabilized Black

Per Bag	ACT Part Number	Color & Material	Length Inch/mm	Width Inch/mm	Thickness Inch/mm	Tie Tensile	Bundle Diameter	Per Case	Mil-Spec Reference
1,000	AL-05-40-9-M	Natural	5.7/144.7	.140/3.556	.049/1.244	40 lb.	1/16 - 1 7/16	20,000	MS3367-5-9
100	AL-05-40-9-C	Nylon							
1,000	AL-05-40-0-M	UV Black	5.7/144.7	.140/3.556	.049/1.244	40 lb.	1/16 - 1 7/16	20,000	MS3367-5-0
100	AL-05-40-0-C	Nylon							
1,000	AL-05-40-30-M	Heat Stabilized	5.7/144.7	.140/3.556	.049/1.244	40 lb.	1/16 - 1 7/16	20,000	MS3367-5-0
100	AL-05-40-30-C	Black Nylon							
1,000	AL-08-40-9-M	Natural	8.8/223.5	.140/3.556	.049/1.244	40 lb.	1/16 - 2 3/8	10,000	
100	AL-08-40-9-C	Nylon							
1,000	AL-08-40-0-M	UV Black	8.8/223.5	.140/3.556	.049/1.244	40 lb.	1/16 - 2 3/8	10,000	
100	AL-08-40-0-C	Nylon							
1,000	AL-08-40-30-M	Heat Stabilized	8.8/223.5	.140/3.556	.049/1.244	40 lb.	1/16 - 2 3/8	10,000	
100	AL-08-40-30-C	Black Nylon							
100	AL-11-40-9-C	Natural Nylon	11.5/292.1	.142/3.606	.055/1.397	40 lb.	1/16 - 3 3/8	5,000	
100	AL-11-40-0-C	UV Black Nylon							
100	AL-14-40-9-C	Natural Nylon	14.5/368.3	.142/3.606	.055/1.397	40 lb.	1/16 - 4	5,000	
100	AL-14-40-0-C	UV Black Nylon							

* Tolerance: .xxx = +/- .005, .xx = +/- .015, Fraction = +/- 1/32"

* 2 Week Delivery Time For Heat Stabilized Ties

* 5" & 8" UL Recognized / CSA Approved

Standard (50 lb) Natural, UV Black & Heat Stabilized Black

Per Bag	ACT Part Number	Color & Material	Length Inch/mm	Width Inch/mm	Thickness Inch/mm	Tie Tensile	Bundle Diameter	Per Case	Mil-Spec Reference
1,000	AL-07-50-9-M	Natural	7.5/190.5	.178/4.521	.053/1.346	50 lb.	1/16 - 1 7/8	10,000	MS3367-1-9
100	AL-07-50-9-C	Nylon							
1,000	AL-07-50-0-M	UV Black	7.5/190.5	.178/4.521	.053/1.346	50 lb.	1/16 - 1 7/8	10,000	MS3367-1-0
100	AL-07-50-0-C	Nylon							
1,000	AL-07-50-30-M	Heat Stabilized	7.5/190.5	.178/4.521	.053/1.346	50 lb.	1/16 - 1 7/8	10,000	MS3367-1-0
100	AL-07-50-30-C	Black Nylon							
500	AL-11-50-9-D	Natural	11.2/284.4	.178/4.521	.053/1.346	50 lb.	1/16 - 3 1/16	5,000	MS3367-7-9
100	AL-11-50-9-C	Nylon							
500	AL-11-50-0-D	UV Black	11.2/284.4	.178/4.521	.053/1.346	50 lb.	1/16 - 3 1/16	5,000	MS3367-7-0
100	AL-11-50-0-C	Nylon							
500	AL-11-50-30-D	Heat Stabilized	11.2/284.4	.178/4.521	.053/1.346	50 lb.	1/16 - 3 1/16	5,000	MS3367-7-0
100	AL-11-50-30-C	Black Nylon							
500	AL-14-50-9-D	Natural	14.5/368.3	.178/4.521	.053/1.346	50 lb.	1/16 - 4 1/8	5,000	MS3367-2-9
100	AL-14-50-9-C	Nylon							
500	AL-14-50-0-D	UV Black	14.5/368.3	.178/4.521	.053/1.346	50 lb.	1/16 - 4 1/8	5,000	MS3367-2-0
100	AL-14-50-0-C	Nylon							
500	AL-14-50-30-D	Heat Stabilized	14.5/368.3	.178/4.521	.053/1.346	50 lb.	1/16 - 4 1/8	5,000	MS3367-2-0
100	AL-14-50-30-C	Black Nylon							
100	AL-17-50-9-C	Natural Nylon	17.0/432.0	.190/4.826	.053/1.346	50 lb.	1/16 - 4 3/4	5,000	
100	AL-17-50-0-C	UV Black Nylon							

* Tolerance: .xxx = +/- .005, .xx = +/- .015, Fraction = +/- 1/32"

* 2 Week Delivery Time For Heat Stabilized Ties

* 7", 11" & 14" UL Recognized / CSA Approved



Tel: 800-861-7228 - email: sales@advancedcableties.com

Fax: 978-630-3999 - Web: www.advancedcableties.com

Heavy Duty (120 lb) Natural, UV Black & Heat Stabilized Black

Per Bag	ACT Part Number	Color & Material	Length Inch/mm	Width Inch/mm	Thickness Inch/mm	Tie Tensile	Bundle Diameter	Per Case	Mil-Spec Reference
100	AL-08-120-9-C	Natural Nylon	8.7/220.9	.300/7.620	.075/1.900	120 lb.	3/16 - 2 1/16	3,000	
100	AL-08-120-0-C	UV Black Nylon							
100	AL-08-120-30-C	Heat Stabilized Black							
100	AL-14-120-9-C	Natural Nylon	15.1/383.5	.300/7.620	.075/1.900	120 lb.	3/16 - 4 1/16	2,000	MS3367-3-9
50	AL-14-120-9-L	Nylon							
100	AL-14-120-0-C	UV Black Nylon							
50	AL-14-120-0-L	Nylon							MS3367-3-0
100	AL-14-120-30-C	Heat Stabilized Black							
50	AL-14-120-30-L	Black							
50	AL-18-120-9-L	Natural Nylon	17.75/450.8	.300/7.620	.075/1.900	120 lb.	3/16 - 5 1/4	1,000	
50	AL-18-120-0-L	UV Black Nylon							
50	AL-24-120-9-L	Natural Nylon	24.2/614.6	.300/7.620	.075/1.900	120 lb.	3/16 - 7	500	
50	AL-24-120-0-L	UV Black Nylon							
50	AL-28-120-9-L	Natural Nylon	28.0/711.2	.300/7.620	.075/1.900	120 lb.	3/16 - 8	500	
50	AL-28-120-0-L	UV Black Nylon							

* Tolerance: .xxx = +/-0.005, .xx = +/-0.015, Fraction = +/-1/32"

* 2 Week Delivery Time For Heat Stabilized Ties

* 8" & 14" UL Recognized / CSA Approved

Extra Heavy Duty (175 lb) Natural, UV Black & Gray

Per Bag	ACT Part Number	Color & Material	Length Inch/mm	Width Inch/mm	Thickness Inch/mm	Tie Tensile	Bundle Diameter	Per Case	Mil-Spec Reference
50	AL-24-175-9-L	Natural Nylon	25.3/642.6	.340/8.636	.090/2.286	175 lb.	3/16 - 7 3/16	500	MS3367-10-9
50	AL-24-175-0-L	UV Black Nylon							MS3367-10-0
50	AL-33-175-9-L	Natural Nylon	33.1/840.7	.340/8.636	.090/2.286	175 lb.	3/16 - 9 3/4	500	MS3367-12-9
50	AL-33-175-0-L	UV Black Nylon							MS3367-12-0
50	AL-36-175-9-L	Natural Nylon	37.1/942.3	.340/8.636	.090/2.286	175 lb.	3/16 - 11	500	MS3367-13-9
50	AL-36-175-0-L	UV Black Nylon							MS3367-13-0
50	AL-48-175-9-L	Natural Nylon	48.5/1231.9	.340/8.636	.090/2.286	175 lb.	3/8 - 14 1/2	500	MS3367-16-9
50	AL-48-175-8-L	Gray Nylon							MS3367-16-8
50	AL-48-175-0-L	UV Black Nylon							MS3367-16-0

* Tolerance: .xxx = +/-0.005, .xx = +/-0.015, Fraction = +/-1/32"

* 24", 33", 36" & 48" UL Recognized / CSA Approved

250 lb Series Natural & UV Black

Per Bag	ACT Part Number	Color & Material	Length Inch/mm	Width Inch/mm	Thickness Inch/mm	Tie Tensile	Bundle Diameter	Per Case	Mil-Spec Reference
100	AL-22-250-9-C	Natural Nylon	22.8/579.1	.50/12.70	.080/2.032	250 lb.	3/16 - 6	500	
100	AL-22-250-0-C	UV Black Nylon							



Tel: 800-861-7228 - email: sales@advancedcableties.com

Fax: 978-630-3999 - Web: www.advancedcableties.com



3 13 1 7 11 15 14 6 12 8 4 5 2
 Photo does not represent actual color of ties. Please contact Customer Service for a 7" 50lb color sample.

Color # Chart

1=Brown	5=Green	11=Fluorescent Green*
2=Red	6=Blue	12=Fluorescent Pink*
3=Orange	7=Purple	13=Fluorescent Yellow*
4=Yellow	8=Gray	14=Fluorescent Orange*
		15=Fluorescent Blue*

*Military Specifications Do Not Apply To Fluorescent Colors

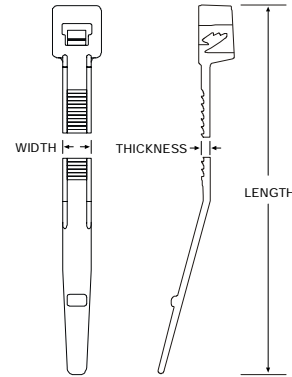

4" (18 lb) Color & Fluorescent

Per Bag	ACT Part Number	Color	Length Inch/mm	Width Inch/mm	Thickness Inch/mm	Tie Tensile	Bundle Diameter	Per Case	Mil-Spec Reference
1,000	AL-04-18-#-M	Colors	4.0/101.6	.094/2.387	.042/1.066	18 lb.	1/16 - 7/8	25,000	MS3367-4-#
1,000	AL-04-18-#-M	Fluorescents							

* Tolerance: .xxx = +/-0.005, .xx = +/-0.015, Fraction = +/-1/32"

* 2 Week Delivery Time For Color Ties

* UL Recognized / CSA Approved

5" (40 lb) Color & Fluorescent

Per Bag	ACT Part Number	Color	Length Inch/mm	Width Inch/mm	Thickness Inch/mm	Tie Tensile	Bundle Diameter	Per Case	Mil-Spec Reference
1,000	AL-05-40-#-M	Colors	5.7/144.7	.140/3.556	.049/1.244	40 lb.	1/16 - 1 7/16	20,000	MS3367-5-#
1,000	AL-05-40-#-M	Fluorescents							

* Tolerance: .xxx = +/-0.005, .xx = +/-0.015, Fraction = +/-1/32"

* 2 Week Delivery Time For Color Ties

* UL Recognized / CSA Approved



Tel: 800-861-7228 - email: sales@advancedcableties.com
 Fax: 978-630-3999 - Web: www.advancedcableties.com

8" (40 lb) Color & Fluorescent

Per Bag	ACT Part Number	Color	Length Inch/mm	Width Inch/mm	Thickness Inch/mm	Tie Tensile	Bundle Diameter	Per Case	Mil-Spec Reference
1,000	AL-08-40-#-M	Colors	8.8/223.5	.140/3.556	.049/1.244	40 lb.	1/16 - 2 3/8	10,000	
1,000	AL-08-40-#-M	Fluorescents							

* Tolerance: .xxx = +/-0.005, .xx = +/-0.015, Fraction = +/-1/32"

* 2 Week Delivery Time For Color Ties

* UL Recognized / CSA Approved

7" (50 lb) Color & Fluorescent

Per Bag	ACT Part Number	Color	Length Inch/mm	Width Inch/mm	Thickness Inch/mm	Tie Tensile	Bundle Diameter	Per Case	Mil-Spec Reference
1,000	AL-07-50-#-M	Colors	7.5/190.5	.178/4.521	.053/1.346	50 lb.	1/16 - 1 7/8	10,000	MS3367-1-#
1,000	AL-07-50-#-M	Fluorescents							

* Tolerance: .xxx = +/-0.005, .xx = +/-0.015, Fraction = +/-1/32"

* 2 Week Delivery Time For Color Ties

* UL Recognized / CSA Approved

11" (50 lb) Color & Fluorescent

Per Bag	ACT Part Number	Color	Length Inch/mm	Width Inch/mm	Thickness Inch/mm	Tie Tensile	Bundle Diameter	Per Case	Mil-Spec Reference
500	AL-11-50-#-D	Colors	11.2/284.48	.178/4.521	.053/1.346	50 lb.	1/16 - 3 1/16	5,000	MS3367-7-#
500	AL-11-50-#-D	Fluorescents							

* Tolerance: .xxx = +/-0.005, .xx = +/-0.015, Fraction = +/-1/32"

* 2 Week Delivery Time For Color Ties

* UL Recognized / CSA Approved

14" (50 lb) Color & Fluorescent

Per Bag	ACT Part Number	Color	Length Inch/mm	Width Inch/mm	Thickness Inch/mm	Tie Tensile	Bundle Diameter	Per Case	Mil-Spec Reference
500	AL-14-50-#-D	Colors	14.5/368.3	.178/4.521	.053/1.346	50 lb.	1/16 - 4 1/8	5,000	MS3367-2-#
500	AL-14-50-#-D	Fluorescents							

* Tolerance: .xxx = +/-0.005, .xx = +/-0.015, Fraction = +/-1/32"

* 2 Week Delivery Time For Color Ties

* UL Recognized / CSA Approved



Tel: 800-861-7228 - email: sales@advancedcableties.com
 Fax: 978-630-3999 - Web: www.advancedcableties.com



Standard ACTPAC

Total Pcs	ACT Part Number	Cable Tie Part #	Pcs Per ACTPAC	Color & Material	Tie Length Inch/mm	Tie Tensile	Bundle Diameter	Mil-Spec Reference	Per Case
400	AL-ACTPAC-400-9	11-50-9	100	Natural Nylon	11.2/284.4	50 lb.	1/16 - 3 1/16	MS3367-7-9	20
Clam Shell Dimensions: 15" x 7 1/8" x 2" PVC		07-50-9	100	Natural Nylon	7.5/190.5	50 lb.	1/16 - 1 7/8	MS3367-1-9	
		04-18-9	200	Natural Nylon	4.0/101.6	18 lb.	1/16 - 7/8	MS3367-4-9	
400	AL-ACTPAC-400-0	11-50-0	100	UV Black Nylon	11.2/284.4	50 lb.	1/16 - 3 1/16	MS3367-7-0	20
Clam Shell Dimensions: 15" x 7 1/8" x 2" PVC		07-50-0	100	UV Black Nylon	7.5/190.5	50 lb.	1/16 - 1 7/8	MS3367-1-0	
		04-18-0	200	UV Black Nylon	4.0/101.6	18 lb.	1/16 - 7/8	MS3367-4-0	

* Tolerance: .xxx = +/- .005, .xx = +/- .015, Fraction = +/- 1/32"

* Sold In Case Quantities Only - Mixed Cases Available

* UL Recognized / CSA Approved Cable Ties

Tension Tool ACTPAC

Total Pcs	ACT Part Number	Cable Tie Part #	Pcs Per ACTPAC	Color & Material	Tie Length Inch/mm	Tie Tensile	Bundle Diameter	Mil-Spec Reference	Per Case
401	AL-ACTPAC-401-A100-9	11-50-9	100	Natural Nylon	11.2/284.4	50 lb.	1/16 - 3 1/16	MS3367-7-9	20
Clam Shell Dimensions: 15" x 7 1/8" x 2" PVC		07-50-9	100	Natural Nylon	7.5/190.5	50 lb.	1/16 - 1 7/8	MS3367-1-9	
		04-18-9	200	Natural Nylon	4.0/101.6	18 lb.	1/16 - 7/8	MS3367-4-9	
		AL-100	1	Twist Cut Off Tension Tool for 18 to 50 lb. Cable Ties					
401	AL-ACTPAC-401-A100-0	11-50-0	100	UV Black Nylon	11.2/284.4	50 lb.	1/16 - 3 1/16	MS3367-7-0	20
Clam Shell Dimensions: 15" x 7 1/8" x 2" PVC		07-50-0	100	UV Black Nylon	7.5/190.5	50 lb.	1/16 - 1 7/8	MS3367-1-0	
		04-18-0	200	UV Black Nylon	4.0/101.6	18 lb.	1/16 - 7/8	MS3367-4-0	
		AL-100	1	Twist Cut Off Tension Tool for 18 to 50 lb. Cable Ties					

* Tolerance: .xxx = +/- .005, .xx = +/- .015, Fraction = +/- 1/32"

* Sold In Case Quantities Only - Mixed Cases Available

* UL Recognized / CSA Approved Cable Ties



Tel: 800-861-7228 - email: sales@advancedcableties.com

Fax: 978-630-3999 - Web: www.advancedcableties.com

Yellow & Red Wire Connector ACTPAC

Total Pcs	ACT Part Number	Cable Tie Part #	Pcs Per ACTPAC	Color & Material	Tie Length Inch/mm	Tie Tensile	Bundle Diameter	Mil-Spec Reference	Per Case
250	AL-ACTPAC-250-YWRD-9 Clam Shell Dimensions: 15" x 7 1/8" x 2" PVC	11-50-9	100	Natural Nylon	11.2/284.4	50 lb.	1/16 - 3 1/16	MS3367-7-9	20
		07-50-9	100	Natural Nylon	7.5/190.5	50 lb.	1/16 - 1 7/8	MS3367-1-9	
		ACN-YW	25	Yellow	Narrow Wire Connectors 3 #18 thru 3 #12 600V				
		ACN-RD	25	Red	Narrow Wire Connectors 2 #14 thru 2 #10 600V				
250	AL-ACTPAC-250-YWRD-0 Clam Shell Dimensions: 15" x 7 1/8" x 2" PVC	11-50-0	100	UV Black Nylon	11.2/284.4	50 lb.	1/16 - 3 1/16	MS3367-7-0	20
		07-50-0	100	UV Black Nylon	7.5/190.5	50 lb.	1/16 - 1 7/8	MS3367-1-0	
		ACN-YW	25	Yellow	Narrow Wire Connectors 3 #18 thru 3 #12 600V				
		ACN-RD	25	Red	Narrow Wire Connectors 2 #14 thru 2 #10 600V				

* Tolerance: .xxx = +/- .005, .xx = +/- .015, Fraction = +/- 1/32"

* Sold In Case Quantities Only - Mixed Cases Available

* UL Recognized / CSA Approved Cable Ties

* UL Listed / CSA Approved Wire Connectors

Blue Wire Connector ACTPAC

Total Pcs	ACT Part Number	Cable Tie Part #	Pcs Per ACTPAC	Color & Material	Tie Length Inch/mm	Tie Tensile	Bundle Diameter	Mil-Spec Reference	Per Case
300	AL-ACTPAC-300-BL-9 Clam Shell Dimensions: 15" x 7 1/8" x 2" PVC	11-50-9	100	Natural Nylon	11.2/284.4	50 lb.	1/16 - 3 1/16	MS3367-7-9	20
		07-50-9	100	Natural Nylon	7.5/190.5	50 lb.	1/16 - 1 7/8	MS3367-1-9	
		ACS-BL	100	Blue	Standard Wire Connectors 1 #18 + 1 #22 thru 3 #16 600V				
300	AL-ACTPAC-300-BL-0 Clam Shell Dimensions: 15" x 7 1/8" x 2" PVC	11-50-0	100	UV Black Nylon	11.2/284.4	50 lb.	1/16 - 3 1/16	MS3367-7-0	20
		07-50-0	100	UV Black Nylon	7.5/190.5	50 lb.	1/16 - 1 7/8	MS3367-1-0	
		ACS-BL	100	Blue	Standard Wire Connectors 1 #18 + 1 #22 thru 3 #16 600V				

* Tolerance: .xxx = +/- .005, .xx = +/- .015, Fraction = +/- 1/32"

* Sold In Case Quantities Only - Mixed Cases Available

* UL Recognized / CSA Approved Cable Ties

* UL Listed / CSA Approved Wire Connectors

3/4" Mounting Pad ACTPAC

Total Pcs	ACT Part Number	Cable Tie Part #	Pcs Per ACTPAC	Color & Material	Tie Length Inch/mm	Tie Tensile	Bundle Diameter	Mil-Spec Reference	Per Case
300	AL-ACTPAC-300-MP750-9 Clam Shell Dimensions: 15" x 7 1/8" x 2" PVC	11-50-9	100	Natural Nylon	11.2/284.4	50 lb.	1/16 - 3 1/16	MS3367-7-9	20
		07-50-9	100	Natural Nylon	7.5/190.5	50 lb.	1/16 - 1 7/8	MS3367-1-9	
		MP-750-9	100	Natural Nylon	.75" / #4 Screw / 18-50 lb Ties / Rubber Adhesive				
300	AL-ACTPAC-300-MP750-0 Clam Shell Dimensions: 15" x 7 1/8" x 2" PVC	11-50-0	100	UV Black Nylon	11.2/284.4	50 lb.	1/16 - 3 1/16	MS3367-7-0	20
		07-50-0	100	UV Black Nylon	7.5/190.5	50 lb.	1/16 - 1 7/8	MS3367-1-0	
		MP-750-0	100	UV Black Nylon	.75" / #4 Screw / 18-50 lb Ties / Rubber Adhesive				

* Tolerance: .xxx = +/- .005, .xx = +/- .015, Fraction = +/- 1/32"

* Sold In Case Quantities Only - Mixed Cases Available

* UL Recognized / CSA Approved Cable Ties & Mounting Pads

1" Mounting Pad ACTPAC

Total Pcs	ACT Part Number	Cable Tie Part #	Pcs Per ACTPAC	Color & Material	Tie Length Inch/mm	Tie Tensile	Bundle Diameter	Mil-Spec Reference	Per Case
250	AL-ACTPAC-250-MP1000-9 Clam Shell Dimensions: 15" x 7 1/8" x 2" PVC	11-50-9	100	Natural Nylon	11.2/284.4	50 lb.	1/16 - 3 1/16	MS3367-7-9	20
		07-50-9	100	Natural Nylon	7.5/190.5	50 lb.	1/16 - 1 7/8	MS3367-1-9	
		MP-1000-9	50	Natural Nylon	1" / #6 Screw / 18-50 lb Ties / Rubber Adhesive				
250	AL-ACTPAC-250-MP1000-0 Clam Shell Dimensions: 15" x 7 1/8" x 2" PVC	11-50-0	100	UV Black Nylon	11.2/284.4	50 lb.	1/16 - 3 1/16	MS3367-7-0	20
		07-50-0	100	UV Black Nylon	7.5/190.5	50 lb.	1/16 - 1 7/8	MS3367-1-0	
		MP-1000-0	50	UV Black Nylon	1" / #6 Screw / 18-50 lb Ties / Rubber Adhesive				

* Tolerance: .xxx = +/- .005, .xx = +/- .015, Fraction = +/- 1/32"

* Sold In Case Quantities Only - Mixed Cases Available

* UL Recognized / CSA Approved Cable Ties & Mounting Pads



Tel: 800-861-7228 - email: sales@advancedcableties.com

Fax: 978-630-3999 - Web: www.advancedcableties.com

New**ACTKIT**

Total Pcs	ACT Part Number	Cable Tie Part #	Pcs Per ACTKIT	Color & Material	Tie Length Inch/mm	Tie Tensile	Bundle Diameter	Mil-Spec Reference	Per Case
801	AL-ACTKIT-801-9	04-18-9	100	Natural Nylon	4.0/101.6	18 lb.	1/16 - 7/8	MS3367-4-9	5
		05-40-9	100	Natural Nylon	5.7/144.7	40 lb.	1/16 - 1 7/16	MS3367-5-9	
		07-50-9	100	Natural Nylon	7.5/190.5	50 lb.	1/16 - 1 7/8	MS3367-1-9	
		14-50-9	100	Natural Nylon	14.5/368.3	50 lb.	1/16 - 4 1/8	MS3367-2-9	
		07-50-MH-9	100	Natural Nylon	8.1/205.7	50 lb.	1/16 - 1 3/4		
		07-50-LP-9	100	Natural Nylon	7.5/190.5	50 lb.	3/8 - 1 3/4	MS3367-23-9	
		MP-750-9	100	Natural Nylon	.75" / #4 Screw / 18-50 lb Ties / Rubber Adhesive				
		MP-1000-9	100	Natural Nylon	1" / #6 Screw / 18-50 lb Ties / Rubber Adhesive				
		AL-100	1	Red	Twist Cut Off Tension Tool for 18 to 50 lb. Cable Ties				

Total Pcs	ACT Part Number	Cable Tie Part #	Pcs Per ACTKIT	Color & Material	Tie Length Inch/mm	Tie Tensile	Bundle Diameter	Mil-Spec Reference	Per Case
801	AL-ACTKIT-801-0	04-18-0	100	UV Black Nylon	4.0/101.6	18 lb.	1/16 - 7/8	MS3367-4-0	5
		05-40-0	100	UV Black Nylon	5.7/144.7	40 lb.	1/16 - 1 7/16	MS3367-5-0	
		07-50-0	100	UV Black Nylon	7.5/190.5	50 lb.	1/16 - 1 7/8	MS3367-1-0	
		14-50-0	100	UV Black Nylon	14.5/368.3	50 lb.	1/16 - 4 1/8	MS3367-2-0	
		07-50-MH-0	100	UV Black Nylon	8.1/205.7	50 lb.	1/16 - 1 3/4		
		07-50-LP-0	100	UV Black Nylon	7.5/190.5	50 lb.	3/8 - 1 3/4	MS3367-23-0	
		MP-750-0	100	UV Black Nylon	.75" / #4 Screw / 18-50 lb Ties / Rubber Adhesive				
		MP-1000-0	100	UV Black Nylon	1" / #6 Screw / 18-50 lb Ties / Rubber Adhesive				
		AL-100	1	Red	Twist Cut Off Tension Tool for 18 to 50 lb. Cable Ties				

* Tolerance: .xxx = +-.005, .xx = +-.015, Fraction = +-1/32"

* Sold In Case Quantities Only

* UL Recognized / CSA Approved Cable Ties & Mounting Pads

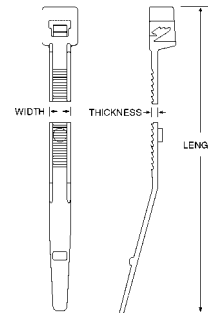
New**Tote Box****Restricted Bundle Diameter**

Per Bag	ACT Part Number	Color & Material	Length Inch/mm	Strap Width Inch/mm	Strap Thick. Inch/mm	Restricted Diameter	Per Case
1,000	AP-05-40-TB-3-M	Orange Nylon	5.7/144.7	.140/3.556	.049/1.244	3/4"	20,000

* Tolerance: .xxx = +-.005, .xx = +-.015, Fraction = +-1/32"

* Sold In Case Quantities Only

* 2 Week Delivery Time

New

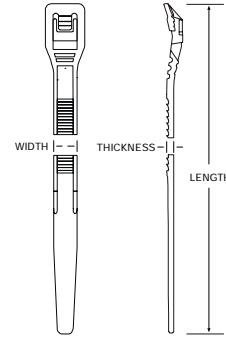

Cobra Series (50 lb & 120 lb)

Per Bag	ACT Part Number	Color & Material	Length Inch/mm	Width Inch/mm	Thickness Inch/mm	Tie Tensile	Bundle Diameter	Per Case	Mil-Spec Reference
1,000	AL-07-50-LP-9-M	Natural Nylon	7.5/190.5	.178/4.521	.053/1.346	50 lb.	3/8 - 1 3/4	10,000	MS3367-23-9
100	AL-07-50-LP-9-C								MS3367-23-0
1,000	AL-07-50-LP-0-M	UV Black Nylon	7.5/190.5	.178/4.521	.053/1.346	50 lb.	3/8 - 1 3/4	10,000	MS3367-23-0
100	AL-07-50-LP-0-C								MS3367-23-0
100	AL-14-120-LP-9-C	Natural Nylon	15.1/383.5	.300/7.620	.075/1.900	120 lb.	9/16 - 3 1/2	2,000	MS3367-25-9
50	AL-14-120-LP-9-L								MS3367-25-9
100	AL-14-120-LP-0-C	UV Black Nylon	15.1/383.5	.300/7.620	.075/1.900	120 lb.	9/16 - 3 1/2	2,000	MS3367-25-0
50	AL-14-120-LP-0-L								MS3367-25-0

* Approximate Dimensions

* 7" UL Recognized / CSA Approved

New

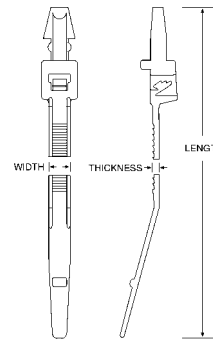

Push Mount

Per Bag	ACT Part Number	Color & Material	Length Inch/mm	Strap Width Inch/mm	Strap Thick. Inch/mm	Tie Tensile	Bundle Diameter	Hole Size	Panel Thickness	Per Case
100	AL-07-50-PM-9-C	Natural Nylon	8.0/203.2	.190/7.826	.055/1.397	50 lb.	1 7/8	1/4"	.14/3.55	5,000
100	AL-07-50-PM-0-C	UV Black Nylon								

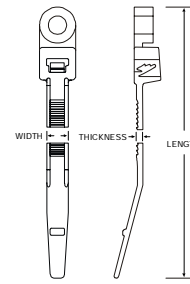

Mounting Hole - Natural & UV Black

Per Bag	ACT Part Number	Color & Material	Length Inch/mm	Strap Width Inch/mm	Strap Thick. Inch/mm	Tie Tensile	Bundle Diameter	Per Case	Screw Size
100	AL-05-30-MH-9-C	Natural Nylon	6.0/152.4	.140/3.55	.048/1.210	30 lb.	1/16 - 1 1/4	10,000	NO. 8
100	AL-05-30-MH-0-C	UV Black Nylon							
1,000	AL-07-50-MH-9-M	Natural Nylon	8.1/205.7	.178/4.52	.053/1.350	50 lb.	1/16 - 1 3/4	5,000	NO. 10
100	AL-07-50-MH-9-C	Nylon							
1,000	AL-07-50-MH-0-M	UV Black Nylon							
100	AL-07-50-MH-0-C	Nylon							
100	AL-11-50-MH-9-C	Natural Nylon	11.8/300.0	.189/4.80	.050/1.270	50 lb.	1/16 - 3	5,000	NO. 10
100	AL-11-50-MH-0-C	UV Black Nylon							
100	AL-14-50-MH-9-C	Natural Nylon	14.5/370.0	.189/4.80	.060/1.524	50 lb.	1/16 - 4	5,000	NO. 10
100	AL-14-50-MH-0-C	UV Black Nylon							
100	AL-14-120-MH-9-C	Natural Nylon	15.66/397.7	.300/7.620	.075/1.900	120 lb.	3/16 - 4 1/16	2,000	1/4"
100	AL-14-120-MH-0-C	UV Black Nylon							

* 7" UL Recognized / CSA Approved

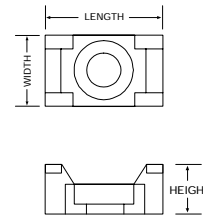

Screw Mounts

SM1 #6 Screw / SM2 1/4" Screw

Per Bag	ACT Part Number	Color & Material	Length Inches/mm	Height Inches/mm	Width Inches/mm	Slot Height Inches/mm	Slot Width Inches/mm	Per Case
100	AL-SM1-9-C	Natural Nylon	.590/14.98	.270/6.858	.370/9.398	.0625/1.587	.190/4.826	15,000
100	AL-SM1-0-C	UV Black Nylon						
100	AL-SM2-9-C	Natural Nylon	.870/22.09	.380/9.652	.640/16.256	.125/3.175	.300/7.620	5,000
100	AL-SM2-0-C	UV Black Nylon						

* Tolerance: .xxx = +-.005, .xx = +-.015, Fraction = +-1/32"



Tel: 800-861-7228 - email: sales@advancedcableties.com
Fax: 978-630-3999 - Web: www.advancedcableties.com

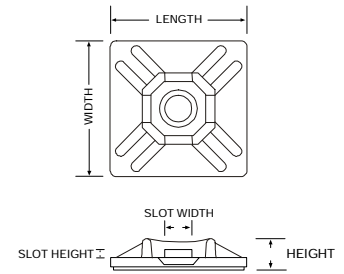

Mounting Pads

MP-750 #4 Screw / MP-1000 #6 Screw

Per Bag	ACT Part Number	Color & Material	Length Inches/mm	Height Inches/mm	Adhesive	Slot Height Inches/mm	Slot Width Inches/mm	Per Case
100	AL-MP-750-9-C	Natural Nylon	.74/18.7	.19/4.8	Rubber	.05/1.2	.20/5.1	10,000
100	AL-MP-750-0-C	Black Nylon						
100	AL-MP-1000-9-C	Natural Nylon	.99/25.1	.20/5.0	Rubber	.06/1.5	5,000	
100	AL-MP-1000-0-C	Black Nylon						
100	AL-MPA-750-9-C	Natural Nylon	.74/18.7	.19/4.8	Acrylic	.05/1.2	10,000	
100	AL-MPA-750-0-C	Black Nylon						
100	AL-MPA-1000-9-C	Natural Nylon	.99/25.1	.20/5.0	Acrylic	.06/1.5	5,000	
100	AL-MPA-1000-0-C	Black Nylon						
100	AL-MP-750-SA-9-C	Natural Nylon	.74/18.7	.19/4.8	Sticky	.05/1.2	10,000	
100	AL-MP-750-SA-0-C	Black Nylon						
100	AL-MP-1000-SA-9-C	Natural Nylon	.99/25.1	.20/5.0	Sticky	.06/1.5	5,000	
100	AL-MP-1000-SA-0-C	Black Nylon						
100	AL-MP-750-NT-9-C	Natural Nylon	.74/18.7	.19/4.8	None	.05/1.2	15,000	
100	AL-MP-750-NT-0-C	Black Nylon						
100	AL-MP-1000-NT-9-C	Natural Nylon	.99/25.1	.20/5.0	None	.06/1.5	10,000	
100	AL-MP-1000-NT-0-C	Black Nylon						

* Tolerance: .xxx = +/- .005, .xx = +/- .015, Fraction = +/- 1/32"

* UL Recognized / CSA Approved Excluding Sticky Adhesive

* 3-4 Week Delivery and 5,000 Piece Minimum Order For Acrylic And Sticky Adhesive

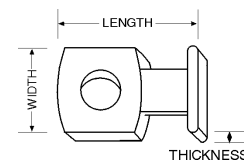

Low Profile Screw Mounts

#8 Screw

Per Bag	ACT Part Number	Color & Material	Length Inches/mm	Height Inches/mm	Width Inches/mm	Slot Height Inches/mm	Slot Width Inches/mm	Per Case
100	AL-LPM1-9-C	Natural Nylon	.75/19.05	.12/3.04	.50/12.70	.062/1.574	.180/4.57	20,000



Tel: 800-861-7228 - email: sales@advancedcableties.com
 Fax: 978-630-3999 - Web: www.advancedcableties.com

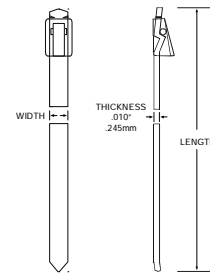

Stainless Steel (150 lb)

Per Bag	ACT Part Number	Material	Length Inch/mm	Width Inch/mm	Tie Tensile	Max Bundle Diameter	Per Case
100	AL-08-150-SS-C	304 Stainless Steel	8.40/213.36	.187/4.749	150 lb.	2"	1,000
100	AL-14-150-SS-C	304 Stainless Steel	14.90/378.46	.187/4.749	150 lb.	4"	1,000
100	AL-20-150-SS-C	304 Stainless Steel	20.90/530.86	.187/4.749	150 lb.	6"	1,000
100	AL-27-150-SS-C	304 Stainless Steel	27.40/695.96	.187/4.749	150 lb.	8"	1,000

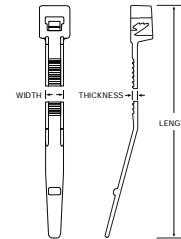

Halar Series (18 lb & 50 lb)

Per Bag	ACT Part Number	Material	Length Inch/mm	Width Inch/mm	Thickness Inch/mm	Tie Tensile	Bundle Diameter	Per Case
100	AL-04-18-HL-C	Halar	4.0/101.6	.094/2.387	.042/1.066	18 lb.	1/16 - 7/8	25,000
100	AL-08-50-HL-C	Halar	8.0/203.2	.178/4.521	.053/1.346	50 lb.	1/16 - 2	5,000

* Approximate Dimensions

* Halar is a trademark of Ausimont Chemical Company.

Tefzel Series (18 lb & 50 lb)

Per Bag	ACT Part Number	Material	Length Inch/mm	Width Inch/mm	Thickness Inch/mm	Tie Tensile	Bundle Diameter	Per Case
100	AL-04-18-TZ-C	Tefzel	4.0/101.6	.094/2.387	.042/1.066	18 lb.	1/16 - 7/8	25,000
100	AL-07-50-TZ-C	Tefzel	7.0/177.8	.178/4.521	.053/1.346	50 lb.	1/16 - 1 7/8	5,000

* Approximate Dimensions

* Tefzel is a trademark of DuPont Corporation.

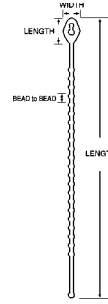

Beaded

Per Bag	ACT Part Number	Color & Material	Length Inch/mm	Head W. Inch/mm	Head L. Inch/mm	Bead Dia. Inch/mm	Bead to Bead	Bundle Diameter	Per Case
100	AL-04-BD-9-C	Natural Nylon	4.0/101.6	.20/5.08	.35/8.89	.09/2.28	.13/3.30	1	20,000
100	AL-06-BD-9-C	Natural Nylon	6.0/152.4	.29/7.36	.57/14.47	.11/2.79	.17/4.31	1 1/2	15,000
100	AL-08-BD-9-C	Natural Nylon	8.93/226.8	.38/9.65	.85/21.59	.15/3.81	.29/7.36	2 1/2	5,000

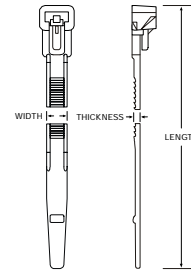

Releasable (50 lb)

Per Bag	ACT Part Number	Color & Material	Length Inch/mm	Width Inch/mm	Thickness Inch/mm	Tie Tensile	Bundle Diameter	Per Case
100	AL-05-50-RL-9-C	Natural Nylon	5.9/149.8	.298/7.569	.050/1.270	50 lb.	1/8 - 1 1/4	5,000
100	AL-05-50-RL-0-C	UV Black Nylon				50 lb.		
100	AL-08-50-RL-9-C	Natural Nylon	7.87/200.0	.298/7.569	.053/1.346	50 lb.	1/8 - 2	5,000
100	AL-08-50-RL-0-C	UV Black Nylon				50 lb.		
100	AL-12-50-RL-9-C	Natural Nylon	11.875/301.6	.314/7.97	.054/1.371	50 lb.	1/8 - 3	3,000
100	AL-12-50-RL-0-C	UV Black Nylon				50 lb.		

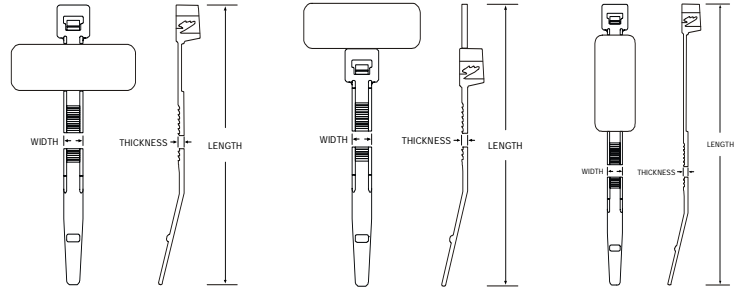
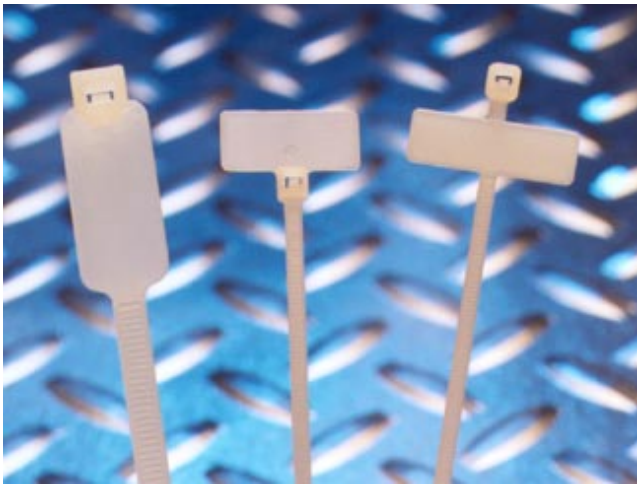

4" Horizontal ID Tie

4" Flag Tie

7" & 14" Vertical ID Tie

Identification & Flag

Per Bag	ACT Part Number	Material & Color	Length Inch/mm	Width Inch/mm	Thickness Inch/mm	Tie Tensile	Bundle Diameter	Pad Size	Per Case
100	AL-04-18-ID-9-C	Natural Nylon	4.0/101.6	.100/2.54	.044/1.117	18 lb.	1/16 - 7/8	5/16" x 1"	10,000
100	AL-04-18-FL-9-C	Natural Nylon	4.3/110.0	.100/2.54	.044/1.117	18 lb.	1/16 - 7/8	5/16" x 1"	10,000
100	AL-07-50-ID-9-C	Natural Nylon	7.8/200.0	.181/4.59	.055/1.397	50 lb.	1/16 - 1 7/8	1/2" x 1 1/8"	5,000
100	AL-14-50-ID-9-C	Natural Nylon	14.1/358.1	.187/4.749	.055/1.397	50 lb.	3/8 - 4	1/2" x 2 1/4"	5,000



AL-100



AL-200



AL-300



AL-900

Tension Tools

Per Box	ACT Part Number	Description
1	AL-100	Twist Cut Off Tension Tool for 18-50 lb. Ties
1	AL-200	Automatic Cut Off and Adjustable Tension Tool for 18-50 lb. Ties
1	AL-300	Manual Cut Off Heavy Duty Tension Tool for 120-175 lb. Ties
1	AL-900	Manual Cut Off Tension Tool for Stainless Steel Ties



AL-MARK-01/11



AL-MARK-15/16



AL-MARK-100

Cloth Wire Marker Booklets

ACT Part Number	Imprint	Markers per imprint	Overall Booklet Dimensions	Marker Dimensions	Quantity Per Booklet
AL-MARK-01	0 - 9	60 (0-4) 30 (5-9)	3 3/8" x 5 3/4"	.25 x 1.25	450
AL-MARK-02	A - Z 0 - 15 +, -, /	10	3 3/8" x 5 3/4"	.25 x 1.25	450
AL-MARK-03	1 - 45	10	3 3/8" x 5 3/4"	.25 x 1.25	450
AL-MARK-04	1, 2, 3	150	3 3/8" x 5 3/4"	.25 x 1.25	450
AL-MARK-05	A, B, C	150	3 3/8" x 5 3/4"	.25 x 1.25	450
AL-MARK-06	T1, T2, T3	150	3 3/8" x 5 3/4"	.25 x 1.25	450
AL-MARK-07	L1, L2, L3	150	3 3/8" x 5 3/4"	.25 x 1.25	450
AL-MARK-08	46 - 90	10	3 3/8" x 5 3/4"	.25 x 1.25	450
AL-MARK-09	10 NEMA Colors	45	3 3/8" x 5 3/4"	.25 x 1.25	450
AL-MARK-10	+, -, AC, DC, Pos., Neg., Neut., Gnd, Spare, Blank	342	3 3/8" x 5 3/4"	.25 x 1.25	342
AL-MARK-11	Circuit Breaker legends: Kitchen Outlets, Range, Bath 1 Lights, Dryer, etc. 79 imprints; various legends	79	3 3/8" x 5 3/4"	.25 x 1.50	90
	Blank	11			

Mini Dispenser & Identification Tape

ACT Part Number	Item	Description
AL-MARK-15	0-9 Mini Dispenser	Dispenses 1/4" x 1 1/4" pre-cut markers with legends (76 each)
AL-MARK-16	0-9 Re-fill Rolls	Box of 10 refill rolls with legends (76 each)
AL-MARK-100	Write-Wrap Dispenser	3/4" x 1 1/4" markers - 300 per dispenser



Light Duty Nylon Cable Clamps

3/8 Wide - #10 Screw

Per Bag	ACT Part Number	Color & Material	Mounting Hole Inch/mm	Closed Diameter Inch/mm	Center to Center Inch/mm	Thickness Inch/mm	Per Case
100	AL-CCL-125-9-C	Natural Nylon	.203/5.156	.125/3.175	.343/8.712	.050/1.270	10,000
100	AL-CCL-125-0-C	Black Nylon					
100	AL-CCL-187-9-C	Natural Nylon	.203/5.156	.187/4.749	.378/9.601	.050/1.270	10,000
100	AL-CCL-187-0-C	Black Nylon					
100	AL-CCL-250-9-C	Natural Nylon	.203/5.156	.250/6.350	.421/10.693	.050/1.270	10,000
100	AL-CCL-250-0-C	Black Nylon					
100	AL-CCL-312-9-C	Natural Nylon	.203/5.156	.312/7.924	.441/11.201	.050/1.270	10,000
100	AL-CCL-312-0-C	Black Nylon					
100	AL-CCL-375-9-C	Natural Nylon	.203/5.156	.375/9.525	.464/11.785	.050/1.270	5,000
100	AL-CCL-375-0-C	Black Nylon					
100	AL-CCL-437-9-C	Natural Nylon	.203/5.156	.437/11.099	.500/12.700	.050/1.270	5,000
100	AL-CCL-437-0-C	Black Nylon					
100	AL-CCL-500-9-C	Natural Nylon	.203/5.156	.500/12.700	.530/13.462	.050/1.270	5,000
100	AL-CCL-500-0-C	Black Nylon					

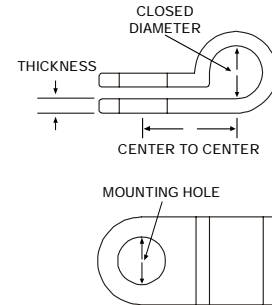

Heavy Duty Nylon Cable Clamps

1/2 Wide - #10 Screw

Per Bag	ACT Part Number	Color & Material	Mounting Hole Inch/mm	Closed Diameter Inch/mm	Center to Center Inch/mm	Thickness Inch/mm	Per Case
100	AL-CCL2-250-9-C	Natural Nylon	.203/5.156	.250/6.350	.437/11.099	.060/1.524	10,000
100	AL-CCL2-250-0-C	Black Nylon					
100	AL-CCL2-312-9-C	Natural Nylon	.203/5.156	.312/7.924	.474/12.039	.060/1.524	5,000
100	AL-CCL2-312-0-C	Black Nylon					
100	AL-CCL2-375-9-C	Natural Nylon	.203/5.156	.375/9.525	.500/12.700	.060/1.524	5,000
100	AL-CCL2-375-0-C	Black Nylon					
100	AL-CCL2-437-9-C	Natural Nylon	.203/5.156	.437/11.099	.533/13.538	.060/1.524	5,000
100	AL-CCL2-437-0-C	Black Nylon					
100	AL-CCL2-500-9-C	Natural Nylon	.203/5.156	.500/12.700	.553/14.046	.060/1.524	5,000
100	AL-CCL2-500-0-C	Black Nylon					
100	AL-CCL2-625-9-C	Natural Nylon	.203/5.156	.625/15.875	.625/15.875	.060/1.524	3,000
100	AL-CCL2-625-0-C	Black Nylon					
100	AL-CCL2-687-9-C	Natural Nylon	.203/5.156	.687/17.449	.665/16.891	.060/1.524	3,000
100	AL-CCL2-687-0-C	Black Nylon					
100	AL-CCL2-750-9-C	Natural Nylon	.203/5.156	.750/19.050	.699/17.754	.060/1.524	3,000
100	AL-CCL2-750-0-C	Black Nylon					
100	AL-CCL2-875-9-C	Natural Nylon	.203/5.156	.875/22.225	.795/20.193	.060/1.524	2,000
100	AL-CCL2-875-0-C	Black Nylon					
100	AL-CCL2-1000-9-C	Natural Nylon	.203/5.156	1.000/25.400	.825/20.955	.060/1.524	2,000
100	AL-CCL2-1000-0-C	Black Nylon					



Split Loom - UV Black Polyethylene

Per Roll	ACT Part Number	Material	Color	Min. Inside Diameter Inches	Max. Outside Diameter Inches	Tolerance
100'	AL-SLPE-250-0-C	Polyethylene	UV Black	.239	.400	+-.030
3200'	AL-SLPE-250-0-B					
100'	AL-SLPE-375-0-C	Polyethylene	UV Black	.351	.526	+-.030
1900'	AL-SLPE-375-0-B					
100'	AL-SLPE-500-0-C	Polyethylene	UV Black	.473	.700	+-.030
1100'	AL-SLPE-500-0-B					
100'	AL-SLPE-625-0-C	Polyethylene	UV Black	.603	.839	+-.030
800'	AL-SLPE-625-0-B					
100'	AL-SLPE-750-0-C	Polyethylene	UV Black	.707	.989	+-.030
500'	AL-SLPE-750-0-B					
100'	AL-SLPE-1000-0-C	Polyethylene	UV Black	1.006	1.320	+-.030
300'	AL-SLPE-1000-0-B					
250'	AL-SLPE-1250-0-B	Polyethylene	UV Black	1.207	1.493	+-.030
150'	AL-SLPE-1500-0-B	Polyethylene	UV Black	1.566	1.932	+-.030

* Material Characteristics May Affect Dimensions.



Cable Wrap - Forward Cut Polyethylene

Per Roll	ACT Part Number	Color	Material	Outside Diameter Inches	Min-Max Bundle	Wall Thickness
100'	AL-CWP-125-9-C	Natural	Polyethylene	.125	1/8 to 1/2	.032
100'	AL-CWP-125-0-C	UV Black				
100'	AL-CWP-187-9-C	Natural	Polyethylene	.187	3/16 to 1 1/2	.030
100'	AL-CWP-187-0-C	UV Black				
100'	AL-CWP-250-9-C	Natural	Polyethylene	.250	1/4 to 2	.045
100'	AL-CWP-250-0-C	UV Black				
100'	AL-CWP-375-9-C	Natural	Polyethylene	.375	3/8 to 3	.052
100'	AL-CWP-375-0-C	UV Black				
100'	AL-CWP-500-9-C	Natural	Polyethylene	.500	1/2 to 4	.062
100'	AL-CWP-500-0-C	UV Black				
100'	AL-CWP-625-9-C	Natural	Polyethylene	.625	5/8 to 4 1/2	.062
100'	AL-CWP-625-0-C	UV Black				
100'	AL-CWP-750-9-C	Natural	Polyethylene	.750	3/4 to 5	.065
100'	AL-CWP-750-0-C	UV Black				
100'	AL-CWP-1000-9-C	Natural	Polyethylene	1.000	1 to 7	.080
100'	AL-CWP-1000-0-C	UV Black				

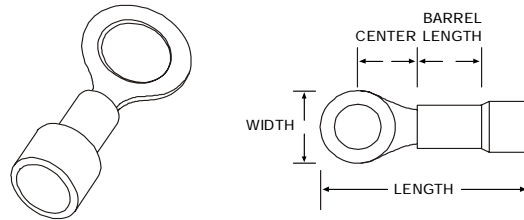

Vinyl Insulated Ring Terminals

Per Bag	ACT Part #	Copper Cond. Range	Stud Size	Color & Material	Max. Stock Size	Insul. Diam.	Approx. Dimensions in Inches				Per Case
							L	W	C	B	
100	AL-R4A-6-C	22-18	6	Red Vinyl	.030	.145	.80	.25	.22	.250	10,000
100	AL-R4A-8-C	22-18	8	Red Vinyl	.030	.145	.90	.33	.29	.250	
100	AL-R4A-10-C	22-18	10	Red Vinyl	.030	.145	1.08	.47	.40	.250	
100	AL-R4A-14-C	22-18	1/4								
100	AL-R4A-56-C	22-18	5/16								
100	AL-R4A-38-C	22-18	3/8	Red Vinyl	.030	.145	1.13	.56	.40	.250	10,000
100	AL-R4B-6-C	16-14	6	Blue Vinyl	.030	.170	.80	.25	.22	.250	
100	AL-R4B-8-C	16-14	8	Blue Vinyl	.030	.170	.90	.33	.29	.250	
100	AL-R4B-10-C	16-14	10								
100	AL-R4B-14-C	16-14	1/4								
100	AL-R4B-56-C	16-14	5/16	Blue Vinyl	.030	.170	1.13	.56	.40	.250	
100	AL-R4B-38-C	16-14	3/8	Blue Vinyl	.030	.170	1.13	.56	.40	.250	
100	AL-R4C-6-C	12-10	5-6	Yellow Vinyl	.040	.250	1.03	.38	.29	.250	10,000
100	AL-R4C-8-C	12-10	8								
100	AL-R4C-10-C	12-10	10								
100	AL-R4C-14-C	12-10	1/4								
100	AL-R4C-56-C	12-10	5/16								
100	AL-R4C-38-C	12-10	3/8	Yellow Vinyl	.040	.250	1.26	.53	.44	.250	
100	AL-R4C-38-C	12-10	3/8	Yellow Vinyl	.040	.250	1.29	.59	.44	.250	

* UL Listed - CSA Approved

* 600 Volts



Tel: 800-861-7228 - email: sales@advancedcableties.com

Fax: 978-630-3999 - Web: www.advancedcableties.com

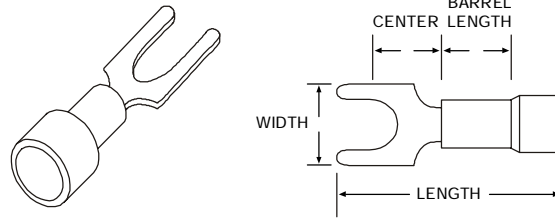

Vinyl Insulated Spade Terminals - Butted Seam

Per Bag	ACT Part #	Copper Cond. Range	Stud Size	Color & Material	Max. Stock Size	Insul. Diam.	Approx. Dimensions in Inches				Per Case
							L	W	C	B	
100	AL-S4A-6-C	22-18	6	Red Vinyl	.030	.145	.85	.30	.25	.250	10,000
100	AL-S4A-8-C	22-18	8								
100	AL-S4A-10-C	22-18	10								
100	AL-S4B-6-C	16-14	6	Blue Vinyl	.030	.170	.85	.30	.25	.250	10,000
100	AL-S4B-8-C	16-14	8								
100	AL-S4B-10-C	16-14	10								
100	AL-S4C-6-C	12-10	4-6	Yellow Vinyl	.032	.250	1.03	.32	.29	.250	10,000
100	AL-S4C-8-C	12-10	8								
100	AL-S4C-10-C	12-10	10								

* UL Listed - CSA Approved

* 600 Volts

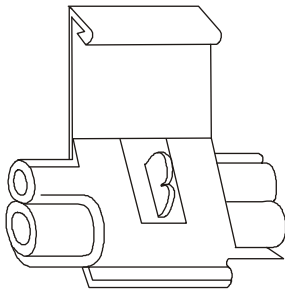

Quick Splicers

Per Bag	ACT Part Number	Color & Material	Wire Range	Per Case
100	AL-PLA-C	Red Vinyl	22-18 Tap / 18-14 Run	3,000
100	AL-PLB-C	Blue Vinyl	18-16 Tap / 14 Run	3,000
100	AL-PLC-C	Yellow Vinyl	12-10 Tap / 10 Run	3,000

* A-PLB-C & A-PLC-C Are UL Listed

* 600 Volts

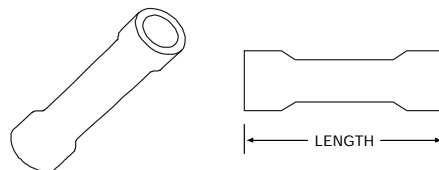

Vinyl Insulated Butt Connectors

Per Bag	ACT Part #	Copper Cond. Range	Color & Material	Stock Size	Max. Insul. Diam.	Length	Per Case
100	AL-B4A-C	22-18	Red Vinyl	.030	.145	1.00	10,000
100	AL-B4B-C	16-14	Blue Vinyl	.030	.170	1.00	10,000
100	AL-B4C-C	12-10	Yellow Vinyl	.040	.250	1.02	5,000

* UL Listed - CSA Approved

* 600 Volts

Fully Insulated Female Disconnects

Per Bag	ACT Part #	Copper Cond. Range	Tab Thickness x Width	Length	Per Case
100	AL-CFR4NA250F-C	22-18	.032 x .250	.87	10,000
100	AL-CFR4NB250F-C	16-14	.032 x .250	.87	10,000

* UL Listed - CSA Approved
 * 600 Volts

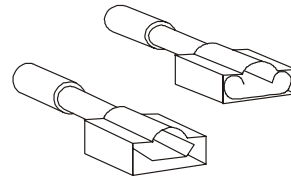

Fully Insulated Male Disconnects

Per Bag	ACT Part #	Copper Cond. Range	Tab Thickness x Width	Length	Per Case
100	AL-CM4TNA250F-C	22-18	.032 x .250	.95	10,000
100	AL-CM4TNB250F-C	16-14	.032 x .250	.95	10,000

* UL Listed - CSA Approved
 * 600 Volts

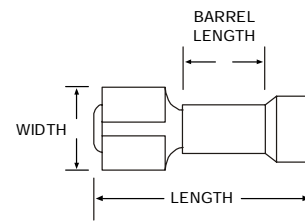
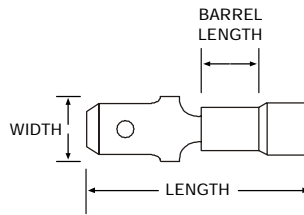
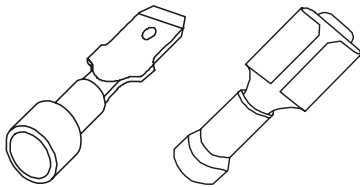
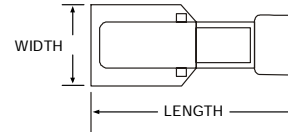

Vinyl Insulated Male Disconnects - Butted Seam

Per Bag	ACT Part #	Copper Cond. Range	Color & Material	Stock Size	Max. Insul. Diam.	Approx Dimensions in inches			Per Case
						L	W	B	
100	AL-MT4A250-C	22-18	Red Vinyl	.032	.145	.93	.250	.250	10,000
100	AL-MT4B250-C	16-14	Blue Vinyl	.032	.170	.93	.250	.250	10,000
100	AL-MT4C250-C	12-10	Yellow Vinyl	.032	.250	1.05	.250	.250	10,000

* UL Listed - CSA Approved
 * 600 Volts

Vinyl Insulated Female Disconnects - Butted Seam

Per Bag	ACT Part #	Copper Cond. Range	Color & Material	Stock Size	Max. Insul. Diam.	Approx Dimensions in inches			Per Case
						L	W	B	
100	AL-FR4A250-C	22-18	Red Vinyl	.032	.145	.87	.250	.250	10,000
100	AL-FR4B250-C	16-14	Blue Vinyl	.032	.145	.87	.250	.250	10,000
100	AL-FR4C250-C	12-10	Yellow Vinyl	.032	.250	.95	.250	.250	10,000

* UL Listed - CSA Approved
 * 600 Volts

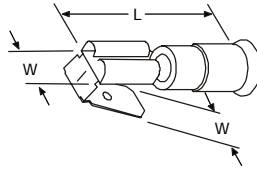

Vinyl Insulated Piggyback Disconnects

Per Bag	ACT Part #	Copper Cond. Range	Color & Material	Width	Thick.	Length	Barrel Length	Max. Insul. Dia.	Per Case
100	AL-PBA-C	22-18	Red Vinyl	.250	.032	.870	.230	.145	10,000
100	AL-PBB-C	16-14	Blue Vinyl	.250	.032	.870	.230	.170	10,000

* 600 Volts

Vinyl Insulated Male Snap Plugs

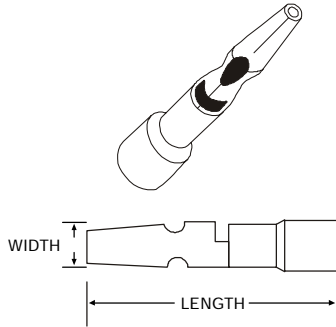

Per Bag	ACT Part #	Copper Cond. Range	Color & Material	Stud Size	Length	Barrel Length	Per Case
100	AL-SC4A-C	22-18	Red Vinyl	.156	.85	.190	10,000
100	AL-SC4B-C	16-14	Blue Vinyl	.156	.85	.190	10,000
100	AL-SC4B1-C	16-14	Blue Vinyl	.180	.85	.190	10,000

* UL Listed - CSA Approved

* 600 Volts

Nylon Insulated Female Snap Plugs

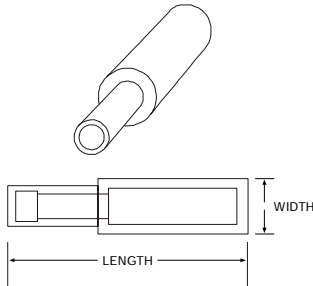

Per Bag	ACT Part #	Copper Cond. Range	Material	Stud Size	Length	Barrel Length	Per Case
100	AL-FSCA-156F-C	22-18	Nylon	.156	1.02	.250	10,000
100	AL-FSC-156F-C	16-14	Nylon	.156	1.02	.250	10,000
100	AL-FSC1-156F-C	16-14	Nylon	.180	1.02	.250	10,000

* UL Recognized - CSA Approved

* 600 Volts

Nylon Pigtails - Seamless

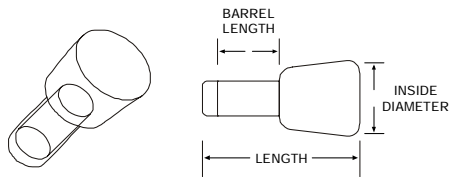

Per Bag	ACT Part #	Copper Cond. Range	Approx Dimensions in inches			Per Case
			L	B	I.D.	
100	AL-NPAB1-C	22-14	.76	.31	.091	10,000
100	AL-NPBC1-C	18-10	.85	.34	.152	10,000

* UL Listed - CSA Approved

* 600 Volts

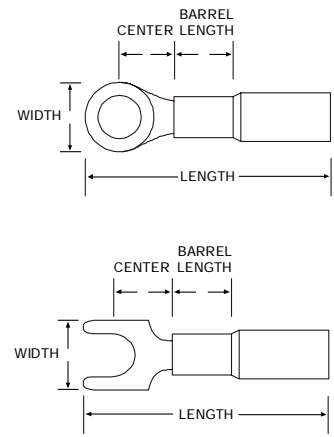
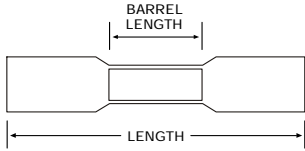

Heat Shrink Butt Connectors

Per Bag	ACT Part #	Copper Cond. Range	Color	Stock Size	Barrel Length	Length	Per Case
25	AL-B4A-HS-Q	22-18	Red	.031	.280	1.20	10,000
25	AL-B4B-HS-Q	16-14	Blue	.031	.300	1.30	10,000
25	AL-B4C-HS-Q	12-10	Yellow	.031	.380	1.50	10,000

* UL Listed - CSA Approved

Heat Shrink Ring Terminals

Per Bag	ACT Part #	Copper Cond. Range	Stud Size	Color	Width	Center	Length	Stock Size	Barrel Length	Per Case
25	AL-R4A-10-HS-Q	22-18	10	Red	.310	.200	1.00	.030	.250	10,000
25	AL-R4B-10-HS-Q	16-14	10	Blue	.310	.200	1.00	.030	.250	
25	AL-R4B-14-HS-Q	16-14	1/4	Blue	.470	.260	1.10	.030	.250	
25	AL-R4B-56-HS-Q	16-14	5/16	Blue	.470	.330	1.10	.030	.250	10,000
25	AL-R4B-38-HS-Q	16-14	3/8	Blue	.560	.280	1.10	.030	.250	
25	AL-R4C-10-HS-Q	12-10	10	Yellow	.380	.210	1.10	.040	.250	10,000
25	AL-R4C-14-HS-Q	12-10	1/4	Yellow	.590	.290	1.20	.040	.250	
25	AL-R4C-38-HS-Q	12-10	3/8	Yellow	.590	.290	1.20	.040	.250	

* UL Listed - CSA Approved

Heat Shrink Spade Terminals

Per Bag	ACT Part #	Copper Cond. Range	Stud Size	Color	Width	Center	Length	Stock Size	Barrel Length	Per Case
25	AL-S4A-6-HS-Q	22-18	6	Red	.250	.250	.90	.030	.250	10,000
25	AL-S4A-8-HS-Q	22-18	8	Red	.250	.250	.90	.030	.250	
25	AL-S4A-10-HS-Q	22-18	10	Red	.320	.250	.90	.030	.250	
25	AL-S4B-6-HS-Q	16-14	6	Blue	.250	.250	.90	.030	.250	10,000
25	AL-S4B-8-HS-Q	16-14	8	Blue	.300	.250	.90	.030	.250	
25	AL-S4B-10-HS-Q	16-14	10	Blue	.320	.250	.90	.030	.250	
25	AL-S4C-8-HS-Q	12-10	8	Yellow	.320	.280	1.00	.040	.250	10,000
25	AL-S4C-10-HS-Q	12-10	10	Yellow	.320	.280	1.00	.040	.250	

* UL Listed - CSA Approved

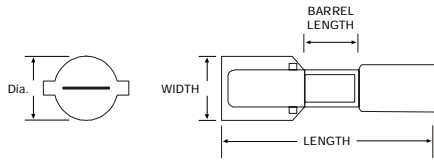

Heat Shrink Fully Insulated Female Disconnects

Per Bag	ACT Part #	Copper Cond. Range	Color	Tab Width x Thickness	Width	Dia.	Length	Barrel Length	Barrel I.D.	Per Case
25	AL-CFR4NA250F-HS-Q	22-18	Red	.250 x .032	.370	.230	1.20	.250	.080	10,000
25	AL-CFR4NB250F-HS-Q	16-14	Blue	.250 x .032	.370	.230	1.20	.250	.080	10,000
25	AL-CFR4NC250F-HS-Q	12-10	Yellow	.250 x .032	.390	.320	1.20	.250	.080	10,000

Heat Shrink Fully Insulated Male Disconnects

Per Bag	ACT Part #	Copper Cond. Range	Color	Tab Width x Thickness	Width	Dia.	Length	Barrel Length	Barrel I.D.	Per Case
25	AL-CM4TNA250F-HS-Q	22-18	Red	.250 x .032	.440	.300	1.20	.250	.065	10,000
25	AL-CM4TNB250F-HS-Q	16-14	Blue	.250 x .032	.440	.300	1.20	.250	.085	10,000
25	AL-CM4TNC250F-HS-Q	12-10	Yellow	.250 x .032	.470	.390	1.20	.250	.150	10,000



Heat Shrink Tubing - Adhesive Lined

Per Bag	ACT Part #	Color & Material	Dia. Inch/mm	Length Inch/mm	Recovered Inch/mm	Per Case
10	AL-HSTU-125-0-X	Black Polyolefin	.125/3.175	12.0/304.8	.040/1.016	2,000
10	AL-HSTU-187-0-X	Black Polyolefin	.187/4.749	12.0/304.8	.062/1.574	2,000
10	AL-HSTU-250-0-X	Black Polyolefin	.250/6.350	12.0/304.8	.080/2.032	1,000
10	AL-HSTU-375-0-X	Black Polyolefin	.375/9.525	12.0/304.8	.120/3.048	500
10	AL-HSTU-500-0-X	Black Polyolefin	.500/12.700	12.0/304.8	.160/4.064	200

Crimp Tool

Per	ACT	
1	TH-450	26-6 AWG Heavy Duty Crimp & Strip Tool.

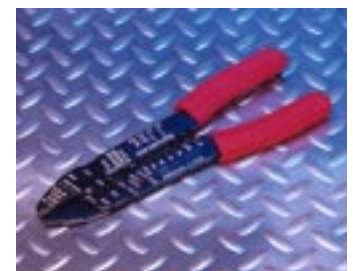

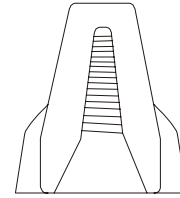
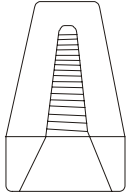
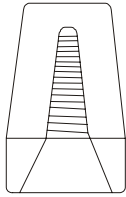

ACTCAP - Standard

Per Bag	ACT Part Number	Color & Material	Wire Range Min.	Wire Range Max.	Voltage	Per Case
100	AL-ACS-GY-C	Gray Thermoplastic	1#18+1#22	2#16	300	10,000
100	AL-ACS-BL-C	Blue Thermoplastic	1#18+1#22	3#16	300	10,000
100	AL-ACS-OR-C	Orange Thermoplastic	1#18+1#20	3#16+1#18	600	5,000
100	AL-ACS-YW-C	Yellow Thermoplastic	3#18	3#12	600	3,000
100	AL-ACS-RD-C	Red Thermoplastic	2#14	2#10	600	2,000

* UL Listed & CSA Approved

ACTCAP - Narrow

Per Bag	ACT Part Number	Color & Material	Wire Range Min.	Wire Range Max.	Voltage	Per Case
100	AL-ACN-OR-C	Orange Thermoplastic	1#18+1#20	3#16+1#18	600	5,000
100	AL-ACN-YW-C	Yellow Thermoplastic	3#18	3#12	600	5,000
100	AL-ACN-RD-C	Red Thermoplastic	2#14	2#10	600	3,000

* UL Listed & CSA Approved

ACTCAP - Wing

Per Bag	ACT Part Number	Color & Material	Wire Range Min.	Wire Range Max.	Voltage	Per Case
100	AL-ACW-YW-C	Yellow Thermoplastic	2#16+1#18	3#14	600	3,000
100	AL-ACW-TN-C	Tan Thermoplastic	3#16	3#12	600	3,000
100	AL-ACW-RD-C	Red Thermoplastic	2#14+1#16	4#12	600	2,000

* UL Listed & CSA Approved

Cross References

Cable Tie Cross Reference

ACT Part #	Catamount	Panduit	Richco	Vision / G&B	Tyton	T & B
AL-04-18-9-M	L-4-18-9-M	PLTIM-M	WIT-18R-M	4-18-N-1000	T18R	TY23M
AL-04-18-9-C	L-4-18-9-C	PLTIM-C	WIT-18R-C	4-18-N-100	T18R-C	TY523M
AL-04-18-0-M	L-4-18-0-M	PLTIM-MO	WIT-18R-BLK-M	4-18-UV-1000	T18R-0	TY23MX
AL-04-18-0-C	L-4-18-0-C	PLTIM-CO	WIT-18R-BLK-C	4-18-UV-100	T18R-0-C	TY523MX
AL-08-18-9-M	L-8-18-9-M	PLT2M-M	WIT-18V-M	8-18-N-1000	T18L	TY232M
AL-08-18-9-C	L-8-18-9-C	PLT2M-C	WIT-18V-C	8-18-N-100	T18L-C	TY5232M
AL-08-18-0-M	L-8-18-0-M	PLT2M-M0	WIT-18V-BLK-M	8-18-UV-1000	T18L-0	TY232MX
AL-08-18-0-C	L-8-18-0-C	PLT2M-C0	WIT-18V-BLK-C	8-18-UV-100	T18L-0-C	TY5232-MX
AL-05-40-9-M	L-5-30-9-M	PLTI.5I-M	WIT-30R-M	6-30-N-1000	T30R	TY24M
AL-05-40-9-C	L-5-30-9-C	PLTI.5I-C	WIT-30R-C	6-30-N-100	T30R-C	TY524M
AL-05-40-0-M	L-5-30-0-M	PLTI.5I-MO	WIT-30R-BLK-M	6-30-UV-1000	T30R-0	TY24MX
AL-05-40-0-C	L-5-30-0-C	PLTI.5I-CO	WIT-30R-BLK-C	6-30-UV-100	T30R-0-C	TY524MX
AL-08-40-9-M	L-8-40-9-M	PLT2I-M	WIT-40L-M	8-30-N-1000	T40R	TY242M
AL-08-40-9-C	L-8-40-9-C	PLT2I-C	WIT-40L-C	8-30-N-100	T40R-C	TY5242M
AL-08-40-0-M	L-8-40-0-M	PLT2I-M0	WIT-40L-BLK-M	8-30-UV-1000	T40R-0	TY242MX
AL-08-40-0-C	L-8-40-0-C	PLT2I-C0	WIT-40L-BLK-C	8-30-UV-100	T40R-0-C	TY5242MX
AL-11-40-9-D	L-11-40-9-M	PLT3I-M	WIT-40VL-M	11-45-N-1000	T40I	TY26M
AL-11-40-9-C	L-11-40-9-C	PLT3I-C	WIT-40VL-C	11-45-N-100	T40I-C	TY526M
AL-11-40-0-D	L-11-40-0-M	PLT3I-M0	WIT-40VL-BLK-M	11-45-UV-1000	T40I-0	TY26MX
AL-11-40-0-C	L-11-40-0-C	PLT3I-C0	WIT-40VL-BLK-C	11-45-UV-100	T40I-0-C	TY526MX
AL-14-40-9-D	L-14-40-9-M	PLT4I-M	-	-	T40L	TY244M
AL-14-40-9-C	L-14-40-9-C	PLT4I-C	-	-	T40L-C	TY5244M
AL-14-40-0-D	L-14-40-0-M	PLT4I-MO	-	-	T40L-0	TY244MX
AL-14-40-0-C	L-14-40-0-C	PLT4I-C0	-	-	T40L-0-C	TY5244MX
AL-07-50-9-M	L-7-50-9-M	PLT2S-M	WIT-50R-M	7-50-N-1000	T50R	TY25M
AL-07-50-9-C	L-7-50-9-C	PLT2S-C	WIT-50R-C	7-50-N-100	T50R-C	TY525M
AL-07-50-0-M	L-7-50-0-M	PLT2S-M0	WIT-50R-BLK-M	7-50-UV-1000	T50R-0	TY25MX
AL-07-50-0-C	L-7-50-0-C	PLT2S-C0	WIT-50R-BLK-C	7-50-UV-100	T50R-0-C	TY525MX
AL-11-50-9-D	L-11-50-9-D	PLT3S-M	WIT-60R-M	11-50-N-1000	T50I	TY253M
AL-11-50-9-C	L-11-50-9-C	PLT3S-C	WIT-60R-C	11-50-N-100	T50I-C	TY5253M
AL-11-50-0-D	L-11-50-0-D	PLT3S-M0	WIT-60R-BLK-M	11-50-UV-1000	T50I-0	TY253MX
AL-11-50-0-C	L-11-50-0-C	PLT3S-C0	WIT-60R-BLK-C	11-50-UV-100	T50I-0-C	TY5253MX
AL-14-50-9-D	L-14-50-9-D	PLT4S-M	WIT-50L-M	14-50-N-1000	T50L	TY28M
AL-14-50-9-C	L-14-50-9-C	PLT4S-C	WIT-50L-C	14-50-N-100	T50L-C	TY528M
AL-14-50-0-D	L-14-50-0-D	PLT4S-M0	WIT-50L-BLK-M	14-50-UV-1000	T50L-0	TY28MX
AL-14-50-0-C	L-14-50-0-C	PLT4S-C0	WIT-50L-BLK-C	14-50-UV-100	T50L0-C	TY528MX
AL-14-120-9-C	L-14-120-9-C	PLT4H-L	WIT-120R-C	14-175-N-100	T120R	TY27M
AL-14-120-0-C	L-14-120-0-C	PLT4H-L0	WIT-120R-BLK-C	14-175-UV-100	T120R-0	TY27MX
AL-24-175-9-L	L-24-175-9-L	PLT6H-L	WIT-175R-L	24-175-N-50	T150M	-
AL-24-175-0-L	L-24-175-0-L	PLT6H-L0	WIT-175R-L-UVB	24-175-UV-50	T150-M0	-
AL-36-175-9-L	L-36-175-9-L	-	-	36-175-N-50	T150LL	TY53510M
AL-36-175-0-L	L-36-175-0-L	-	-	36-175-UV-50	T150LL-0	TY53510MX
AL-48-175-9-L	L-48-175-9-L	PLT13H-C -43"	-	48-175-N-50	T150XLL9	TY54513M -45"
AL-48-175-8-L	L-48-175-8-L	-	-	-	-	-
AL-48-175-0-L	L-48-175-0-L	PLT13H-C0 -43"	-	48-175-UV-50	T150XLL0	TY54513MX -45"

* Please contact Customer Service for companies and parts not listed.



Tel: 800-861-7228 - email: sales@advancedcableties.com
 Fax: 978-630-3999 - Web: www.advancedcableties.com

Mounting Hole Cable Tie Cross Reference

ACT Part #	Catamount	Panduit	Richco	Vision / G&B	Tyton	T & B
AL-05-30-MH-9-M	L-5-30MH-9-M	PLCI.51-S8-M	WITS-8-50MS-M	6M-30-N-1000	T30MR	TY34M
AL-05-30-MH-9-C	L-5-30MH-9-C	PLCI.51-S8-C	WITS-8-50MS-C	6M-30-N-100	T30MR-C	TY534M
AL-05-30-MH-0-M	L-5-30MH-0-M	PLCI.51-S8-M0	WITS-8-50MS-UVB-M	6M-30-UV-1000	T30MR-0-C	TY34MX
AL-05-30-MH-0-C	L-5-30MH-0-C	PLCI.51-S8-C0	WITS-8-50MS-UVB-C	6M-30-UV-100	T30MR-C	TY534MX
AL-07-50-MH-9-M	L-7-50MH-9-M	PLC2S-S10-M	WITS-8-50MRL-M	7M-50-N-1000	T50MR	TY35M
AL-07-50-MH-9-C	L-7-50MH-9-C	PLC2S-S10-C	WITS-8-50MRL-C	7M-50-N-100	T50MR-0-C	TY535M
AL-07-50-MH-0-M	L-7-50MH-0-M	PLC2S-S10-M0	WITS-50MRL-BLK-M	7M-50-UV-1000	T40MR-0	TY35MX
AL-07-50-MH-0-C	L-7-50MH-0-C	PLC2S-S10-C0	WITS-50MRL-BLK-C	7M-50-UV-100	T50MR-0-C	TY535MX
AL-11-50-MH-9-D	L-11-50MH-9-D	PLC3S-S10-M	WITS-11-50MR-M	11M-50-N-1000	-	-
AL-11-50-MH-9-C	L-11-50MH-9-C	PLC3S-S10-C	WITS-11-50MR-C	11M-50-N-100	-	-
AL-11-50-MH-0-D	L-11-50MH-0-D	PLC3S-S10-M0	WITS-11-50MR-BLK-M	11M-50-UV-1000	-	-
AL-11-50-MH-0-C	L-11-50MH-0-C	PLC3S-S10-C0	WITS-11-50MR-BLK-C	11M-50-UV-100	-	-
AL-14-50-MH-9-D	L-14-50MH-9-D	PLC4S-S10-M	WITS-10-50ML-M	14M-50-N-1000	T50ML	TY354M
AL-14-50-MH-9-C	L-14-50MH-9-C	PLC4S-S10-C	WITS-10-50ML-C	14M-50-N-100	T50ML-C	TY5354M
AL-14-50-MH-0-D	L-14-50MH-0-D	PLC4S-S10-M0	WITS-10-50ML-BLK-M	14M-50-UV-1000	T50ML-0	TY354MX
AL-14-50-MH-0-C	A-14-50MH-0-C	PLC4S-S10-C0	WITS-10-50ML-BLK-C	14M-50-UV-100	T50ML-0-C	TY5354MX
AL-14-120-MH-9-C	L-14-120MH-9-C	PLC4H-S25-L	WITS-14-120MR-C	14M-175-N-100	T120MR	TY37M
AL-14-120-MH-0-C	L-14-120MH-0-C	PLC4H-S25-L0	WITS-14-120MR-BLK-C	14M-175-UV-100	T120MR-0	TY37MX

* Please contact Customer Service for companies and parts not listed.

I.D. Cable Tie Cross Reference

ACT Part #	Catamount	Panduit	Richco	Vision / G&B	Tyton	T & B
AL-04-18-ID-9-M	L-4-18ID-9-M	PLMIM-M	WIT-F1-18R-M	4ID-18-N-1000	IT18R	TY51M
AL-04-18-ID-9-C	L-4-18ID-9-C	PLMIM-C	WIT-F1-18R-C	4ID-18-N-100	IT18R-C	TY551M
AL-04-18-FL-9-M	-	PLFIM-M	WIT-F2-18R-M	4IDE-18-N-1000	IT18FL	TY53M
AL-04-18-FL-9-C	-	PLFIM-C	WIT-F2-18R-C	4IDE-18-N-100	1T18FL-C	TY553M
AL-07-50-ID-9-M	L-7-50ID-9-M	PLM2S-M	WIT-F3-50R-M	8ID-50-N-1000	IT50R	TY46M
AL-07-50-ID-9-C	L-7-50ID-9-C	PLM2S-C	WIT-F3-50R-C	8ID-50-N-100	IT50R-C	TY546M
AL-14-50-ID-9-D	-	PLM4S-D	WIT-F3-50L-M	-	IT50L	TY48M
AL-14-50-ID-9-C	-	PLM4S-C	WIT-F3-50L-C	-	IT50L-C	TY548M

* Please contact Customer Service for companies and parts not listed.

Mounting Pad Cross Reference

ACT Part #	Catamount	Panduit	Richco	Vision / G&B	Tyton	T & B
AL-MP-750-9-C	MPNY-750-9-C	ABMM-A-C	FTH-5A-RT-M	MB-10	MB3A10C2	TC344A
AL-MP-750-0-C	MPNY-750-0-C	ABMM-AT-C0	FTH-5A-RT-UVB-M	MB-10UVB	MB3A0C2	TC344AX
AL-MP-1000-9-C	MPNY-1000-9-C	ABM2S-A-C	FTH-7A-RT-M	MB-20	MB4A10C2	TC345A
AL-MP-1000-0-C	MPNY-1000-0-C	ABM2S-AT-C0	FTH-7A-RT-UVB-M	MB-20-UVB	MB4A0C2	TC345AX

* Please contact Customer Service for companies and parts not listed.



Tel: 800-861-7228 - email: sales@advancedcableties.com
 Fax: 978-630-3999 - Web: www.advancedcableties.com

English Fraction & Decimal - Metric Conversion Chart

Fractions	Decimals	Millimeters
1/64	.015625	0.397
1/32	.03125	0.794
3/64	.046875	1.191
1/16	.0625	1.588
5/64	.078125	1.984
3/32	.09375	2.381
7/64	.109375	2.778
1/8	.1250	3.175
9/64	.140625	3.572
5/32	.15625	3.969
11/64	.171875	4.366
3/16	.1875	4.763
13/64	.203125	5.159
7/32	.21875	5.556
15/64	.234375	5.953
1/4	.2500	6.350
17/64	.265625	6.747
9/32	.28125	7.144
19/64	.296875	7.541
5/16	.3125	7.938
21/64	.328125	8.334
11/32	.34375	8.731
23/64	.359375	9.128
3/8	.3750	9.525
25/64	.390625	9.922
13/32	.40625	10.319
27/64	.421875	10.716
7/16	.4375	11.113
29/64	.453125	11.509
15/32	.46875	11.906
31/64	.484375	12.303
1/2	.5000	12.700

Fractions	Decimals	Millimeters
33/64	.515625	13.097
17/32	.53125	13.494
35/64	.546875	13.891
9/16	.5625	14.288
37/64	.578125	14.684
19/32	.59375	15.081
39/64	.609375	15.478
5/8	.6250	15.875
41/64	.640625	16.272
21/32	.65625	16.669
43/64	.671875	17.066
11/16	.6875	17.463
45/64	.703125	17.859
23/32	.71875	18.256
47/64	.734375	18.653
3/4	.7500	19.050
49/64	.765625	19.447
25/32	.78125	19.844
51/64	.796875	20.241
13/16	.8125	20.638
53/64	.828125	21.034
27/32	.84375	21.431
55/64	.859375	21.828
7/8	.8750	22.225
57/64	.890625	22.622
29/32	.90625	23.019
59/64	.921875	23.416
15/16	.9375	23.813
61/64	.953125	24.209
31/32	.96875	24.606
63/64	.984375	25.003
1	1.000	25.400

Military Specification Reference Chart

Mil-Spec	ACT P/N	Color
MS-3367-1-0	A-07-50-0	UV Black
MS-3367-1-9	A-07-50-9	Natural
MS3367-1-1	A-07-50-1	Brown
MS-3367-1-2	A-07-50-2	Red
MS-3367-1-3	A-07-50-3	Orange
MS-3367-1-4	A-07-50-4	Yellow
MS-3367-1-5	A-07-50-5	Green
MS-3367-1-6	A-07-50-6	Blue
MS-3367-1-7	A-07-50-7	Purple
MS-3367-1-8	A-07-50-8	Grey
MS-3367-2-0	A-14-50-0	UV Black
MS-3367-2-9	A-14-50-9	Natural
MS-3367-2-1	A-14-50-1	Brown
MS-3367-2-2	A-14-50-2	Red
MS-3367-2-3	A-14-50-3	Orange
MS-3367-2-4	A-14-50-4	Yellow
MS-3367-2-5	A-14-50-5	Green
MS-3367-2-6	A-14-50-6	Blue

Mil-Spec	ACT P/N	Color
MS-3367-2-7	A-14-50-7	Purple
MS-3367-2-8	A-14-50-8	Grey
MS-3367-3-0	A-14-120-0	UV Black
MS-3367-3-9	A-14-120-9	Natural
MS-3367-4-0	A-04-18-0	UV Black
MS-3367-4-9	A-04-18-9	Natural
MS-3367-4-1	A-04-18-1	Brown
MS-3367-4-2	A-04-18-2	Red
MS-3367-4-3	A-04-18-3	Orange
MS-3367-4-4	A-04-18-4	Yellow
MS-3367-4-5	A-04-18-5	Green
MS-3367-4-6	A-04-18-6	Blue
MS-3367-4-7	A-04-18-7	Purple
MS-3367-4-8	A-04-18-8	Grey
MS-3367-5-0	A-05-40-0	UV Black
MS-3367-5-9	A-05-40-9	Natural
MS-3367-5-1	A-05-40-1	Brown
MS-3367-5-2	A-05-40-2	Red

Mil-Spec	ACT P/N	Color
MS-3367-5-3	A-05-40-3	Orange
MS-3367-5-4	A-05-40-4	Yellow
MS-3367-5-5	A-05-40-5	Green
MS-3367-5-6	A-05-40-6	Blue
MS-3367-5-7	A-05-40-7	Purple
MS-3367-5-8	A-05-40-8	Grey
MS-3367-7-0	A-11-50-0	UV Black
MS-3367-7-9	A-11-50-9	Natural
MS-3367-7-1	A-11-50-1	Brown
MS-3367-7-2	A-11-50-2	Red
MS-3367-7-3	A-11-50-3	Orange
MS-3367-7-4	A-11-50-4	Yellow
MS-3367-7-5	A-11-50-5	Green
MS-3367-7-6	A-11-50-6	Blue
MS-3367-7-7	A-11-50-7	Purple
MS-3367-7-8	A-11-50-8	Grey
MS-3367-10-9	A-24-175-9	Natural
MS-3367-10-0	A-24-175-0	UV Black

Mil-Spec	ACT P/N	Color
MS-3367-12-9	A-33-175-9	Natural
MS-3367-12-0	A-33-175-0	UV Black
MS-3367-13-9	A-36-175-9	Natural
MS-3367-13-0	A-36-175-0	UV Black
MS-3367-16-9	A-48-175-9	Natural
MS-3367-16-8	A-48-175-8	Grey
MS-3367-16-0	A-48-175-0	UV Black
MS-3367-23-9	A-07-50-LP-9	Natural
MS3367-23-0	A-07-50-LP-0	UV Black
MS3367-25-9	A-14-120-LP-9	Natural
MS3367-25-0	A-14-120-LP-0	UV Black

UL # E168851

CSA # 207196

CAGE Code - 03RL1

Operating Characteristics Of ACT's Cable Ties

Cable Tie Material	Temperature Rating	UL Flame Rating	Environment	Regulatory Requirements
Nylon General Purpose	185°F 85°C	94V-2	Indoor	CSA 22.2 UL 1565 SAE AS23190 SAE AS33671
Black Nylon Heat Stabilized	257°F 125°C	94V-2	Indoor	CSA 22.2 UL 1565 SAE AS23190 SAE AS33671
Black Nylon UV Stabilized	185°F 85°C	94V-2	Indoor or Outdoor	CSA 22.2 UL 1565 SAE AS23190 SAE AS33671

* Minimum Installation Temperature Is Greater Than 32°F or 0°C

DISCLAIMER OF WARRANTY AND LIABILITY

Although the information and recommendations set forth herein ("information") are presented in good faith and believed to be correct as of the date hereof, Advanced Cable Ties, Inc. makes no representations or warranties as to the completeness or accuracy thereof. Information is supplied upon the condition that the persons receiving same will make their own determination as to its suitability for their purposes prior to use. In no event will Advanced Cable Ties, Inc. be responsible for damages of any nature whatsoever resulting from the use of or reliance upon information or the product to which information refers. Nothing contained herein is to be construed as a recommendation to use any product, process, equipment or formulation in conflict with any patent, and Advanced Cable Ties, Inc. makes no representation or warranty, expressed or implied, that the use thereof will not infringe upon any patent. No representations or warranties, either expressed or implied, of merchantability, fitness for a particular purpose or of any other nature are made hereunder with respect to information or the product to which information refers.



Tel: 800-861-7228 - email: sales@advancedcableties.com
Fax: 978-630-3999 - Web: www.advancedcableties.com

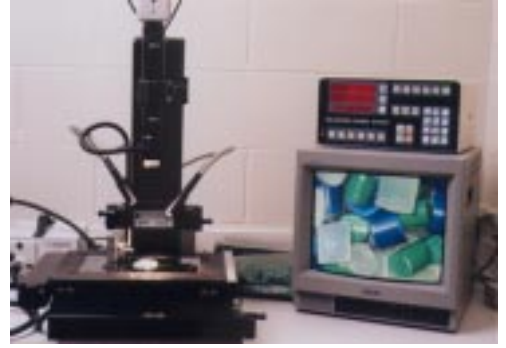

Cable Tie Material Characteristics

A cable tie is a band or length of strap, manufactured from a class of polymeric materials known as polyamides (Nylon 6/6). The width, length and head area employ ratcheting mechanisms which allow for locking as necessary for “bundling” items together.

Commercially introduced in October 1938, Nylon was the first synthetic semi-crystalline polymer whose physical properties compared favorably to some metals. The polymer's high strength and temperature resistance allows it to be used in “engineered” applications thus it falls into a category of polymers known as “engineering thermoplastic.” Nylons are produced from a family of resins, which contain an amide group -CONH-. These materials are then polymerized; a chemical process that links small amide monomers together into a long polymer chain, then called polyamides.

Nylon possesses an outstanding balance of properties, combining strength, moderate stiffness, high service temperature and a high level of toughness. Particularly resistant to repeated impact, nylon has a low coefficient of friction and excellent abrasion resistance. Nylon is resistant to fuels, lubricants and most chemicals, but is attacked by phenols, strong acids and oxidizing agents (ref. Our Physical and Chemical Certification for further information). Nylon is inherently susceptible to environmental conditions. ACT cable ties are moisturized to attain optimum performance levels. Nylon product should be stored in cool dry areas, out of direct sunlight and sealed in the original packaging material. These measures will extend performance levels indefinitely.

General purpose nylon is suitable for use in most practical applications at continuous temperatures up to 150 degrees Fahrenheit. Nylon 6/6, the grade most often used for cable tie production, meets UL 94V-2 flammability ratings. Its working temperature range is from 40 degrees Fahrenheit to 185 degrees Fahrenheit.

Heat Stabilized Nylon 6/6 is used in continuous or extended exposure to high temperatures (up to 250 degrees Fahrenheit). A general-purpose nylon will have a reduction in physical properties and fatigue as a result of high temperatures. Nylon cable ties containing specially formulated heat stabilizers provide additional thermal endurance. Heat stabilized nylons are engineered for continuous exposure to temperatures above 185 degrees Fahrenheit, which meet UL standards for electrical applications.

UV Stabilized Nylon 6/6 is used in continuous or extended exposure to outdoor use. The nylon cable tie is a weather resistant grade, enduring additional ultraviolet (UV) light. This grade is produced by incorporating stabilizers in the nylon resin. UV Stabilized Nylon cable ties are available only in black.

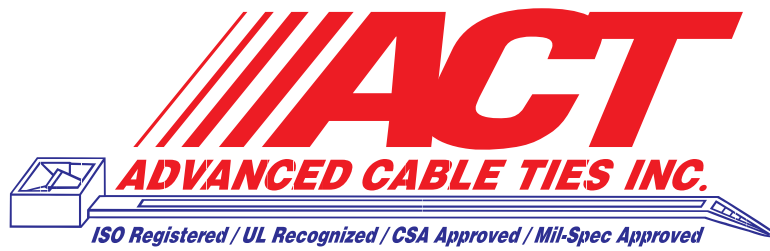

For further assistance please contact Customer Service

Advanced Cable Ties, Inc. • 245 Suffolk Lane • Gardner, MA 01440
Tel: 800-861-7228 • Fax: 978-630-3999
Email: sales@advancedcableties.com
Web: www.advancedcableties.com

03-01

