

# Plasti-Bond **REDH<sub>2</sub>O**<sup>®</sup>

## Buyer's Guide

*Complete Product Information*

*Installation Information*

*Value Added Features & Benefits*

*Technical Information*

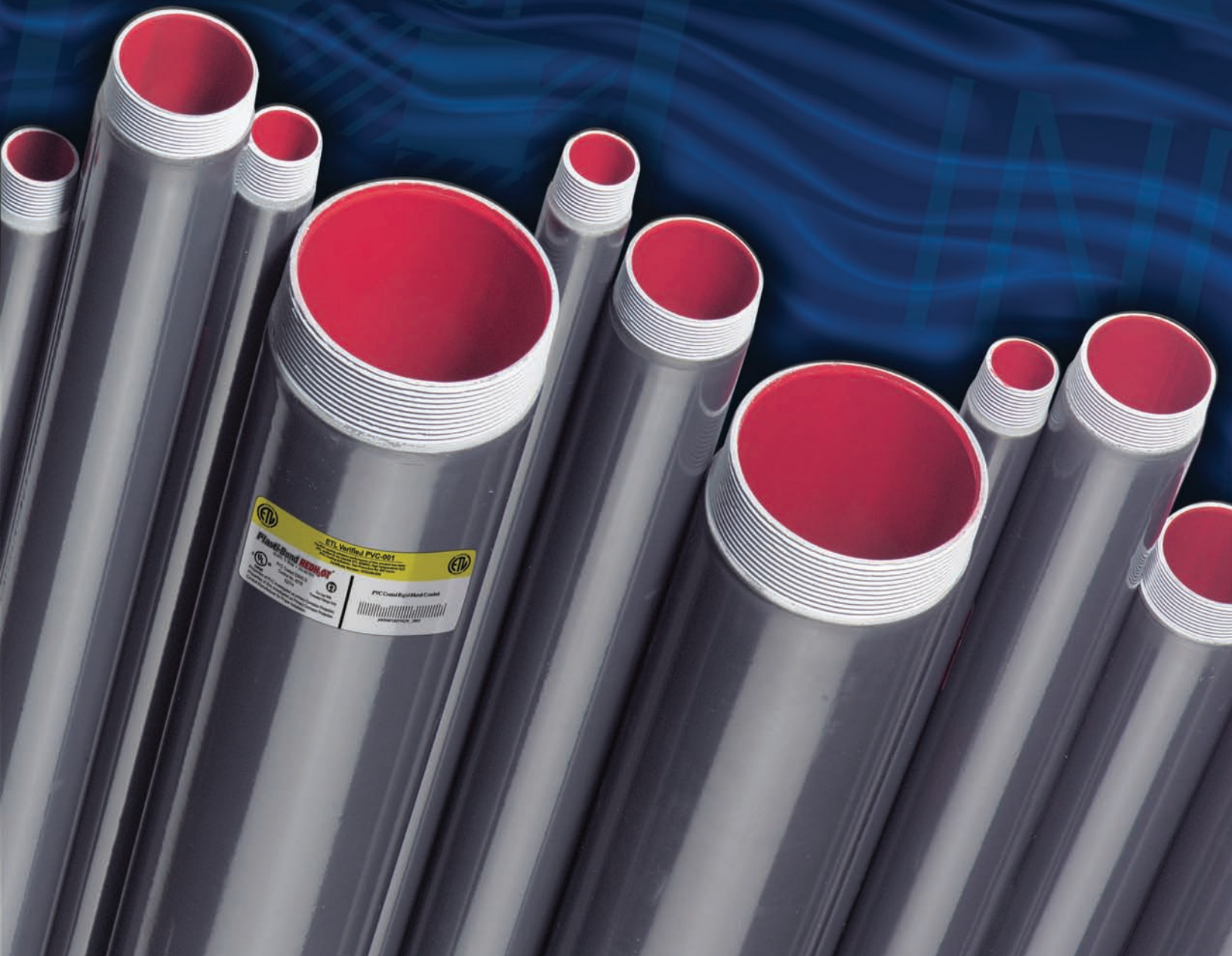

# TABLE OF CONTENTS

## PLASTI-BOND REDH<sub>2</sub>OT TABLE OF CONTENTS

| <b><i>Plasti-Bond REDH<sub>2</sub>OT PVC Coated Products</i></b> | <b>PAGE</b> |
|------------------------------------------------------------------|-------------|
| Conduit and Nipples .....                                        | 1-2         |
| Standard Radius Elbows.....                                      | 3-4         |
| Large Radius Elbows.....                                         | 4           |
| Pulling Elbows .....                                             | 5           |
| Couplings.....                                                   | 6           |
| Conduit Bodies And Covers For General Service Locations.....     | 7-12        |
| Cast Device Boxes.....                                           | 13-18       |
| Conduit Boxes For Hazardous Locations .....                      | 19-21       |
| Sealing Fittings .....                                           | 22-25       |
| Knockout Hubs .....                                              | 26-27       |
| Conduit Unions .....                                             | 28          |
| Malleable Elbows .....                                           | 29          |
| Service Entrance Elbows .....                                    | 30          |
| Expansion Joints .....                                           | 31          |
| Liquid Tight Connectors.....                                     | 32-33       |
| Reducing Couplings and Split Couplings.....                      | 34          |
| Plugs, Grounding Bushings, Reducing Bushings.....                | 35          |
| Pipe Straps & Clamp Back Spacers.....                            | 36-37       |
| Clamp Hangers.....                                               | 36          |
| Thread Rods .....                                                | 36          |
| Strut Nuts .....                                                 | 37          |
| Pipe Straps .....                                                | 37          |
| Strut.....                                                       | 37          |
| Beam Clamps.....                                                 | 38          |
| U-Bolts.....                                                     | 38          |
| Installation Tools .....                                         | 39          |
| Plasti-Bond REDH <sub>2</sub> OT Touch-up Compounds .....        | 39          |
| <br><b><i>Installation Guide</i></b> .....                       | <br>40-46   |
| <br><b><i>Technical Information</i></b> .....                    | <br>47-50   |

### ***General Disclaimers***

1. All weights and dimensions are approximate and are subject to change without notice.
2. Plasti-Bond reserves the right to make engineering changes as needed.
3. Catalog numbers are not intended to represent specific manufacturers.
4. Unless indicated otherwise, all weights and measures are in inch-pound units.
5. Please see current price guide for product availability.

***Plasti-Bond REDH<sub>2</sub>OT***<sup>®</sup>

**Executive Offices:** 1100 US Highway 271 South, Gilmer, Texas 75644  
Phone: 903/843-5591, Sales Department Fax: 903/843-2516, Main Office Fax: 903/843-5595



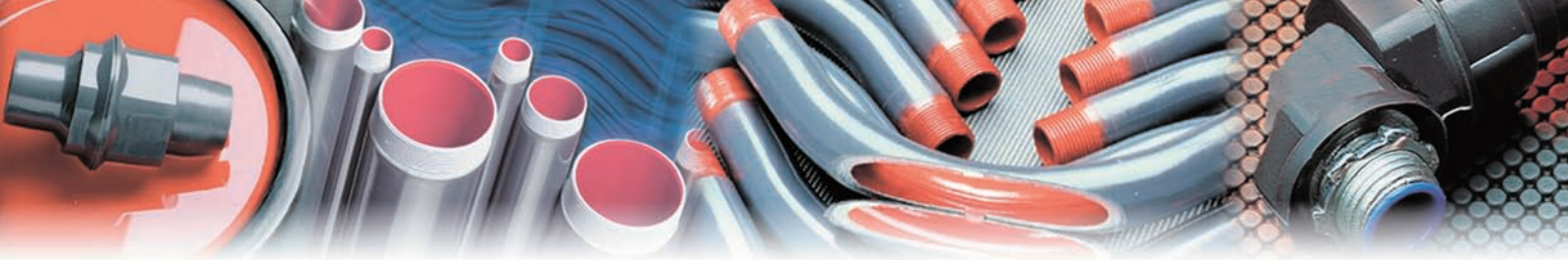

# NOT ALL PVC-COATED GALVANIZED RIGID CONDUIT IS CREATED EQUAL.

**ONLY ETL-LABELED CONDUIT CAN PROVE ITS PERFORMANCE PLASTI-BOND REDH<sub>2</sub>OT... 10 TIMES LONGER PRODUCT LIFE AT NO ADDITIONAL COST.**

## NO EQUAL!



### ETL – THE MARK OF PROVEN PERFORMANCE!

#### FACT ONE:

Plasti-Bond PVC-coated galvanized rigid conduit is authorized to carry both the ETL-verified mark of performance and a UL-rated label. Ocal is not.

#### FACT TWO:

In independent ETL product performance evaluation, Plasti-Bond was consistently maintained successful bonding of protective PVC coating during extended hot water immersion.

In fact...over the course of 200 hours, Plasti-Bond performed ten times more reliably than Ocal.

Ocal's bonding adhesion failed quickly during the identical test. In real life applications failure of PVC to bond with the conduit's metal substrate leads to corrosion destruction and costly product failure.

#### FACT THREE:

ETL-verified heat and humidity tests showed equally dramatic performance superiority of Plasti-Bond when compared in identical testing to Ocal.

#### PROVE IT TO YOURSELF.

HERE'S WHY Plasti-Bond HAS BEEN APPROVED TO CARRY ETL PERFORMANCE VERIFICATION – AND OTHER CONDUIT BRANDS HAVE NOT.

PVC External Coating Adhesion  
Plasti-Bond REDH<sub>2</sub>OT vs. Ocal Blue  
Comparison by Hours of Hot Water Immersion

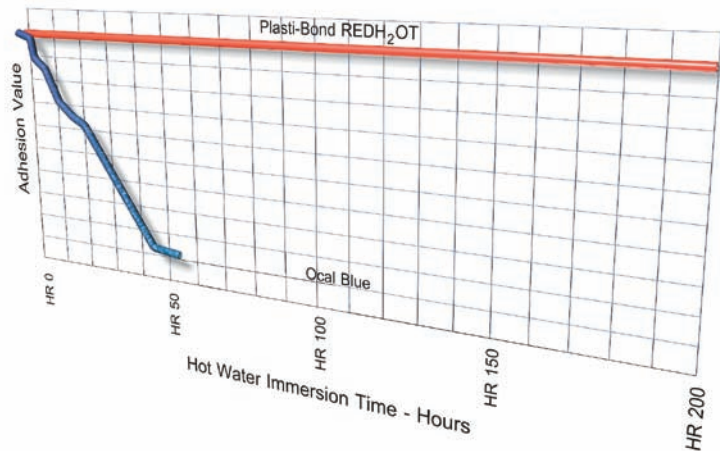

PVC External Coating Adhesion  
Plasti-Bond REDH<sub>2</sub>OT vs. Ocal Blue  
Comparison by Days of Heat/Humidity Exposure  
HEAT/HUMIDITY TEST: 150° F, 95% RELATIVE HUMIDITY

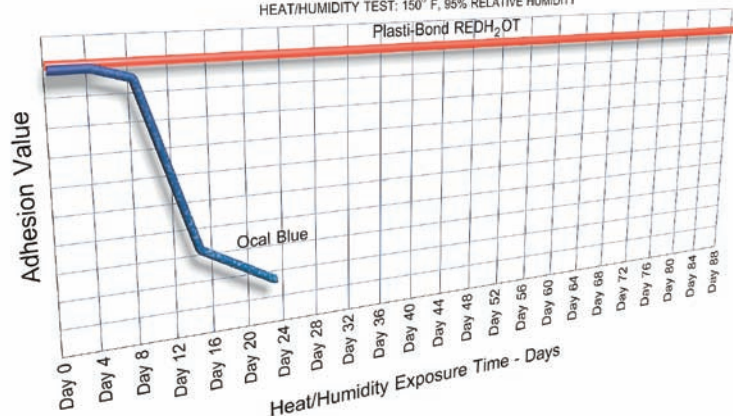

**DEMAND THAT YOUR SUPPLIER OF PVC-COATED METAL CONDUIT PROVE IT TO YOU... WITH THE ETL-VERIFIED LABEL OF PERFORMANCE!**

**ETL Verified PVC-001**

The PVC coating adhesion performance of this product has been ETL verified to the Intertek ETL SEMKO, High Temperature H<sub>2</sub>O PVC Coating Adhesion, Test Procedure for 200 hours. Certificate Number: 3072346-004

---

**Plasti-Bond REDH<sub>2</sub>OT**  
GILMER, TX 75644 • 903-843-5591

**UL** US  
PVC Coated ERMCS Control No. 40TB E2314  
For Use With Threaded Fittings Only

Listed Properties of PVC investigated as primary Corrosion Protection, Properties of Zinc investigated as Primary Corrosion Protection, Consult Manufacturer for Proper Installation.

PVC Coated Rigid Metal Conduit

10450987182370238\_9802



## Bond = Service Life

### Unequaled Bonding

In repeated, independently confirmed ASTM accelerated tests, the exterior and interior coatings of Plasti-Bond REDH<sub>2</sub>OT consistently performed successfully.

Plasti-Bond REDH<sub>2</sub>OT's bond stays strong after immersion testing. The PVC coating protects conduit from corrosion by remaining reliably adhered to the metal.



### Why Our Adhesion Test Proves That You Will Receive The Maximum Corrosion Protection You Paid For!

The "adhesion test" applied to Plasti-Bond coating is based on demanding, independently monitored standards in accordance with ETL-Verification requirements.

Why is that important to you?

Because not all brands of PVC-coated galvanized rigid conduit have passed the stringent requirements of ASTM D870 and ASTM D2247, the two accepted tests designed to predict SERVICE LIFE of a coating under the two most common conditions that affect the adhesive bonds of protective coatings: heat and humidity.

All brands of PVC-coated galvanized rigid conduit manufactured in the U.S. meet exactly the same safety standards established in UL 6. However... not all brands are authorized to carry the ETL PVC-001 label predicting product SERVICE LIFE --- and proving that the protective bonding you paid for will actually do its job.

If product performance and SERVICE LIFE are important to you... look for the ETL-Verification label...it is independent proof that Plasti-Bond's coating will perform reliably as much as ten times longer than brands that are not ETL-Verified!

### After identical immersion testing this is what bonding failure looks like.

When a test tab is pulled on this Non-ETL labeled product it strips away completely, exposing metal substrate. What does that mean? **Failure.**



**Our word is our bond, and our bond is your assurance of the best available corrosion protection.**



## **AEP™...Ensuring That Plasti-Bond REDH<sub>2</sub>OT is Right...Right From The Start!**

AEP™... Adhesion Enhancement Process...is a proprietary treatment system developed to provide an unequalled bond between our PVC and the hot-dipped galvanized conduit it protects.

### **Two Realities About Bonding**

- 1.Surface preparation is the key to a good bond.
- 2.The quality of the bond determines the quality of the corrosion protection.

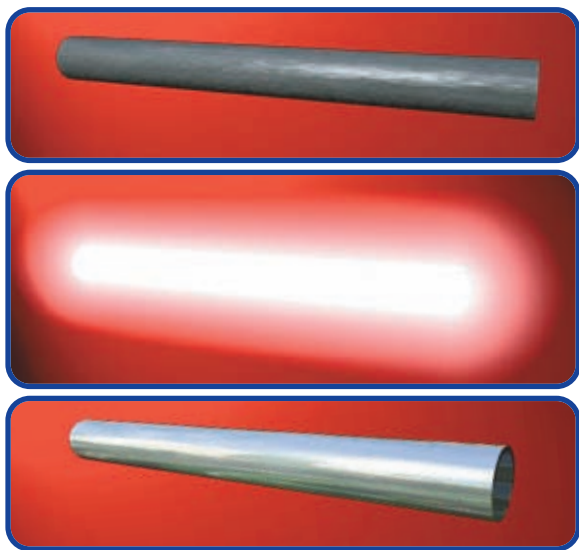

### **AEP...Plasti-Bond REDH<sub>2</sub>OT's Answer To The Challenge Of Bonding**

Our AEP process for Plasti-Bond REDH<sub>2</sub>OT conduit and fittings prepares and controls the zinc coating so it will receive, and hold, the PVC coating.

This is accomplished with proprietary mechanical and chemical methods, as well a special primer coating that only Plasti-Bond REDH<sub>2</sub>OT has. The end result is superior PVC bonding to the metal and the additional backup corrosion protection of zinc.

Plasti-Bond REDH<sub>2</sub>OT outperforms other coated conduit brands because it was prepared right... right from the start.

## **ProTECH™...Nothing Can Touch Our Threads!**

ProTECH™ is a system that provides our conduit threads with unsurpassed corrosion protection.

The ProTECH system represents an investment of almost \$2 million with a single goal of delivering to you the highest quality coated conduit thread possible.

After PVC coating of the conduit, the automated, computer controlled ProTECH process starts with a laser trimming operation to remove excess PVC from the conduit ends. Next is mechanical surface preparation of the previously chemically cleaned conduit threads. This is critical because surface preparation is the key to a good bond. Next, the clean pipe threads are hot-galvanized using specially designed equipment, including 3-axis robotic arms. After hot-galvanizing, the threads are coated with a clear polyurethane spray, protecting the galvanized thread from corrosive attack. Nothing has touched the zinc coating of our threads!



# Price = Cost Value

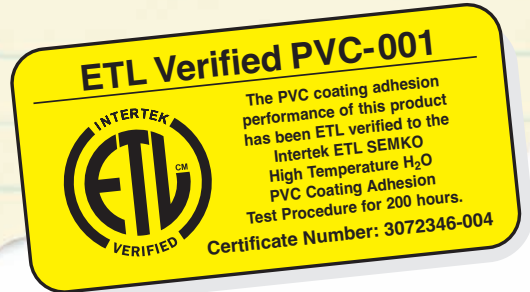

## Price

Plasti-Bond REDH<sub>2</sub>OT pricing is competitive and fair. All we ask is an opportunity to prove it.

## Value

When you buy Plasti-Bond REDH<sub>2</sub>OT you get a combination of value-adds available only from Plasti-Bond.

- Value from the best bond in the industry.
- Value from ETL-Verified Performance testing.
- Value from the best available corrosion protection.
- Value from the longest available product life cycle.
- Value from reduced or eliminated replacement costs.
- Value from ease-of-installation and resulting savings in reduced labor costs and eliminated downtime.
- Value from the industry's best application success rate and iron-clad written warranty.
- Value from the best available customer service and technical support including Installer Certification.
- Value from "the extras":

Customized Installation Tools

Molded Ribbed Couplings Standard

Sealing Sleeves Fit Tightly Over Coated Conduit When Assembled

Encapsulated Stainless Steel Screws

Patented V-Seal Fittings

Gasket Seals On Fittings

Standard And Special Radius Elbows And Nipples

Coated Korn's Clamps Designed For PVC Coated Conduit

Color Coded Thread Protectors

## Cost

Only Plasti-Bond REDH<sub>2</sub>OT provides you the exceptional combination of benefits that add up to unequaled installed value for coated rigid metal conduit.

## Unequaled Installed Value

### Ask Yourself These Questions to Determine Your True Costs:

- Can you afford the risk of unreliable corrosion protection?
- Can you afford to buy and pay to install more conduit to replace faulty conduit that did not provide corrosion protection?
- Can you afford the risk of your operation being impaired or shut down while you replace failed conduit?
- Can you afford the safety risk of conduit failing to provide corrosion protection?

With Plasti-Bond REDH<sub>2</sub>OT, the only choice you need to make is that you want the best corrosion protection for your conduit system. There are three facts to keep in mind:

### Unequaled Bond. Unequaled Corrosion Protection. Unequaled Installed Value.

Only Plasti-Bond REDH<sub>2</sub>OT provides all three. With Plasti-Bond REDH<sub>2</sub>OT, you can install it, and forget it.

**That is a proven  
REDH<sub>2</sub>OT fact.**





## Value Added Features And Benefits Of Plasti-Bond

### **PLASTI-BOND REDH<sub>2</sub>OT'S BOND**

**Feature:** The best in the industry! No Equal!

**Benefit:** Ensures that corrosives never touch the metal.

### **PLASTI-BOND REDH<sub>2</sub>OT'S CHEMICAL RESISTANCE**

**Feature:** Coatings are resistant to a wide range of corrosive chemicals.

**Benefit:** Prevents the exposure of the metal to damaging environments.

### **PLASTI-BOND REDH<sub>2</sub>OT'S SEALING SLEEVES**

**Feature:** PVC sleeves that are sized so they fit tightly over the coated conduit when assembled.

**Benefit:** Keeps corrosive elements from the threaded joints.

### **ADHESION ENHANCEMENT PROCESS (AEP™)**

**Feature:** Plasti-Bond REDH<sub>2</sub>OT receives special surface preparation.

**Benefit:** The best BOND in the industry! No Equal!

### **ENCAPSULATED STAINLESS STEEL SCREWS**

**Feature:** All Form 8 conduit cover screws are made from stainless steel with a plastic encapsulated head.

**Benefit:** Maximum corrosion protection provides a seal around the screw opening.

### **PLASTI-BOND REDH<sub>2</sub>OT POLYURETHANE COATINGS**

**Feature:** Plasti-Bond's polyurethane coatings have been specially formulated.

**Benefit:** Optimum chemical resistance, flexibility, durability, and BOND! No Equal!

### **UV STABILIZED PVC COATING**

**Feature:** Specially formulated UV stabilized PVC coating used on Plasti-Bond REDH<sub>2</sub>OT products.

**Benefit:** Resistant to UV damage. No coating deterioration when exposed outdoors.

### **PROTECH™ SYSTEM - HOT GALVANIZED CONDUIT THREADS AFTER COATING - "NO TOUCH"**

**Feature:** We use a specialized hot galvanizing system on our PVC conduit threads after PVC coating.

**Benefit:** Nothing ever touches the zinc coating on Plasti-Bond REDH<sub>2</sub>OT conduit threads.

### **COMPREHENSIVE LINE OF FACTORY NIPPLES AND ELBOWS, STANDARD, SPECIAL RADIUS**

**Feature:** Quick shipment of a comprehensive line of factory Nipples and Elbows, Standard, Special Radius.

**Benefit:** Faster installation and lower labor costs.

### **V-SEAL® FORM 8 FITTINGS**

**Feature:** Our patented Plasti-Bond REDH<sub>2</sub>OT V-Seal® fittings use a special interlocking V groove.

**Benefit:** Covers effectively seal out corrosive environments.

### **RIBBED COUPLINGS**

**Feature:** Molded ribs on Plasti-Bond REDH<sub>2</sub>OT couplings provide an additional thickness of PVC.

**Benefit:** Protects the coating from cuts and abrasions caused by the teeth of wrenches and other installation tools.

### **PVC GASKET SEALS ON FITTINGS**

**Feature:** Plasti-Bond fittings have sealing sleeves.

**Benefit:** Keeps corrosives from getting into the conduit system through joints and openings, protecting the interior of the system from corrosion.

### **CLAMPS DESIGNED FOR PVC COATED CONDUIT**

**Feature:** All of Plasti-Bond REDH<sub>2</sub>OT PVC coated pipe straps, clamps and clamp back spacers are specially designed to fit PVC coated conduit.

**Benefit:** Proper fit and ease of installation.

### **COLOR CODED THREAD PROTECTORS**

**Feature:** Thread protectors are color coded by size.

**Benefit:** Quick identification of conduit size.

### **INSTALLATION TOOLS**

**Feature:** Special installation tools are available.

**Benefit:** Installation is faster, easier and damage free.

### **FIVE YEAR WARRANTY**

**Feature:** Five Year Warranty.

**Benefit:** Peace of mind.

### **INTERNET WEB SITE [WWW.PLASTIBOND.COM](http://WWW.PLASTIBOND.COM)**

**Feature:** Internet Web Site.

**Benefit:** Convenient, 24-hour a day access to our product catalog, price list, product information, installation instructions, submittal guide, and other useful information. You can also e-mail questions and comments to us.

### **ETL VERIFIED PVC-001:**

The PVC coating adhesion performance of this product has been ETL verified to the Interek ETL SEMKO High Temperature H<sub>2</sub>O PVC Coating Adhesion Test Procedure for 200 hours.



# CORROSION COLLEGE

## Helping You Beat Corrosion Through Education

According to the National Association of Corrosion Engineers, this cost exceeds \$300 billion...per year! Corrosion College, on the other hand, is absolutely free. You cannot afford to miss it!

### Corrosion College includes:

- Two days of intensive instruction conducted by professionals in the field of corrosion protection.
- Hands-on experience in understanding the process of corrosion.
- Exploration of proven strategies for combating corrosion.
- A comprehensive curriculum including case studies and laboratory workshops.
- Interactive presentations detailing the proper installation and anti-corrosion performance of rigid metal PVC-coated conduit and fittings.

### Corrosion College is of direct benefit to:

Specifiers      End-Users      Owners      Engineers  
Purchasing Agents      Distributors      Contractors

### Here are just a few comments from those who found great value in the Corrosion College:

"This course was very well organized."

*D.R. - Design/Material Specialist*

"Demonstrates concern for a quality product."

*D.R. - Contractor*

"Good Texas hospitality, knowledgeable instructors, good communications and worthwhile topics all contributed to a pleasant atmosphere and successful learning session."

*J.H. - Electrical Engineer*

"I enjoyed the course and had fun with the the presenter."

*B.E. - Electrical Engineer*

"A very well done course, I learned alot and thank you guys for having me here."

*F.D. - Electrical Engineer*

"The entire course and stay was EXTREMELY delightful and appreciated greatly... was conducted in a very relaxing and positive way."

*R.W. - Electrical Contractor*

"Although not geared specifically toward my job background as a UL employee, the Corrosion College provided me with a wealth of information that I will be able to apply in my job. More important for my application is that this course gave me a firm understanding of corrosion protection, which I will be able to utilize in developing listing requirements."

*B.W. - Electrical Engineer*

"Hands-on aspect is an outstanding memory aid."

*G.W. - Technical Editor*

"Super!"

*M.M. - Electrical Engineer*

"Absolutely the most pleasant learning experience. Of all my training opportunities I have gotten the most out of this."

*T.M. - Electrical Reliability*

"I found the portion of the course which covered the process of corrosion and corrosion protection (sacrificial vs. barrier) very informative. The staff presenting the class was extremely well informed and made the information interesting. Thank you."

*K.A. - Electrical Engineer*

"Overall this was a joyful, enjoyable experience. Excellent!!"

*P.H. - Major City Water Dept. Engineer*

"I came to learn and DID."

*R.D. - Electrical Contractor*

"A very professional learning adventure that benefited me tremendously. The instructors get A+ for knowledge and teaching methods"

*D.M. - I&E Supervisor*

"I have been to many different types of conferences/seminars/etc. and this has been one of the best I have attended. Job well done."

*B.E. - College Instructor*

"I had no idea that there was so much to learn about corrosion. This was a very good school."

*R.B. - End User E.E.*

**Now Accredited for 1.5  
Continuing Education Units!**





# Installer Certification

## ENSURING THE MOST EFFECTIVE USE OF THE BEST AVAILABLE PRODUCT: PLASTI-BOND REDH<sub>2</sub>OT

We believe in the absolute need for Installer Certification. This is our way of ensuring that Plasti-Bond REDH<sub>2</sub>OT is installed properly and can be depended upon for the high level of reliable performance for which it has been designed and engineered.

Only installers who are able to present the authorized credentials of having passed our instruction and examination are officially certified to install Plasti-Bond's unequalled products. If you require verification of certification, please call our Installer Certification Coordinator at 903-843-5591. We maintain an ongoing master registration log.

We regard Installer Certification as a win-win situation for all involved. Qualified installation provides these benefits:

- The end-user receives optimum installation quality.
- The engineering firm benefits because of obvious concern for providing only the best to the end-user.
- The contractor achieves more cost-effective installation.
- The installer's skills are made even more valuable.
- Everyone gains from more efficient installation times and significantly reduced risks of the need for rework.

Plasti-Bond Installer Certification is based upon training that includes classroom and hands-on instruction encompassing:

- The manufacturing processes of coated conduit.
- Proper installation techniques and tools.
- Hands-on instruction for clamping, cutting, bending, threading and assembly of coated conduit.
- Interactive discussion of techniques and troubleshooting.

**THE FIVE BASIC STEPS FOR PROPER INSTALLATION OF**

**PLASTI-BOND REDH<sub>2</sub>OT®**

- 1 Clamping
- 2 Cutting
- 3 Threading
- 4 Bending
- 5 Assembly

---

**Plasti-Bond REDH<sub>2</sub>OT**

Executive Offices:  
1100 US Highway 271 South  
Gilmer, Texas 75644  
Tel: 903/843-5591  
Fax: 903/843-2516

**5 ASSEMBLY**

- Use Plasti-Bond Touch Up Compound to repair nicks, cuts and abrasions to the exterior of the Plasti-Bond REDH<sub>2</sub>OT conduit.
- Plasti-Bond Touch Up Compound can be used as a sealant at access fitting openings.
- Plasti-Bond REDH<sub>2</sub>OT Z Wrenches are designed to replace standard adjustable pliers and channel locks.
- Using Plasti-Bond REDH<sub>2</sub>OT Spin-it, reduces marks left by wrenches or pliers, saving time and labor.
- Jaws 3 is a set of three aluminum-nickel-bronze vise jaws designed to replace the regular jaws in a pipe vise. When ordering Jaws 3 be sure to specify the vise model.

• Use the Plasti-Bond REDH<sub>2</sub>OT Plasti-Socket and a standard 3/8" ratchet to speed up U Bolt and beam clamp installation.

**Plasti-Bond REDH<sub>2</sub>OT**

Certifies that:

\_\_\_\_\_  
(Certified Installer's Name)

\_\_\_\_\_  
(Company)

has successfully completed The Coated Conduit System Installation Training on this \_\_\_\_\_ day of \_\_\_\_\_ 20\_\_\_\_

\_\_\_\_\_  
Instructor

As a certified Plasti-Bond installer you are now qualified to conduct installation training and authorize certification of new installers

Certificate # \_\_\_\_\_

[www.plastibond.com](http://www.plastibond.com)

Installer certification is free of charge and available at the job site, contractor's shop, factory, or wherever it is convenient to you!

# PLASTI-BOND REDH<sub>2</sub>O<sup>T</sup> COATED GALVANIZED RIGID CONDUIT AND NIPPLES

## COATED CONDUIT

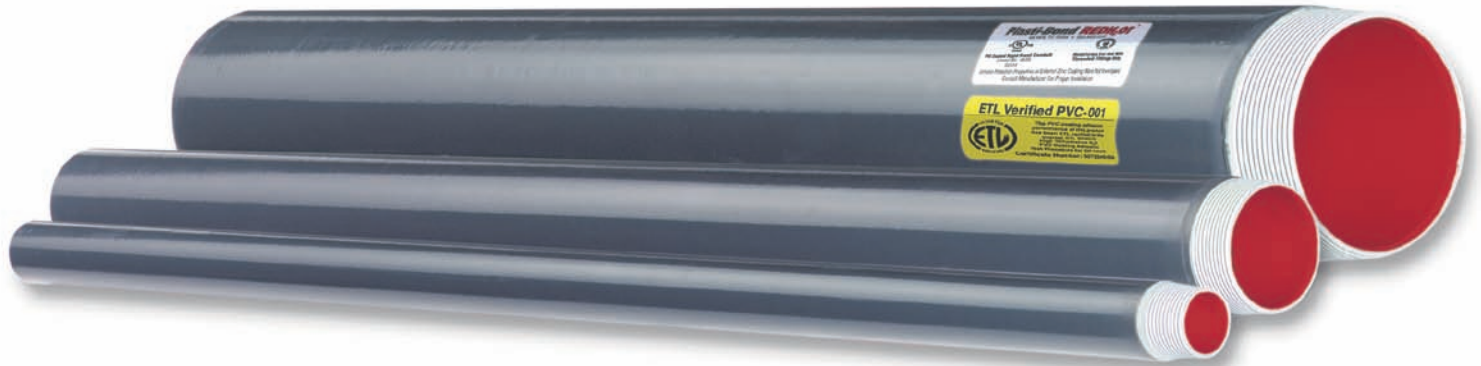

### PVC Coated Galvanized Rigid Conduit Specifications

PVC coated galvanized rigid conduit with red urethane interior coating protects conductors from mechanical damage and corrosive attack. Electrical continuity is maintained across assembled joints.

- 40 mil gray PVC exterior coating
- 2 mil red urethane interior coating
- PROTECH threads – A clear urethane coating over hot galvanized threads
- 12 trade sizes from 1/2" through 6"
- Shipped in 10' lengths
- Plastic thread protector caps are color coded for quick identification of conduit size.

#### Thread Protector Cap Colors:

- Black- for 1/2" sizes, 1/2", 1-1/2", 2-1/2", 3-1/2"
- Red- for 1/4" sizes, 3/4", 1-1/4"
- Blue- for even sizes, 1", 2", 3", 4", 5", 6"

#### Steel and Aluminum

- UL 6 (E2314); UL 6A (E98405)
- CSA C22.2 No. 45
- PVC as the primary corrosion protection for steel conduit. The underlying zinc coating is a supplemental corrosion protection coating. Restricted for use with threaded fittings only.

**ETL VERIFIED PVC-001: The PVC coating adhesion performance of this product has been ETL verified to the Intertek ETL SEMKO High Temperature H<sub>2</sub>O PVC Coating Adhesion Test Procedure for 200 hours.**



### REDH<sub>2</sub>O<sup>T</sup> PRODUCT FLASH

## Plasti-Bond REDH<sub>2</sub>O<sup>T</sup>... The Extra Distance in Protection from Corrosion

### Thread Protection

As a closed system, a coated conduit installation is only as good as its threaded joints. Plasti-Bond offers you ProTech™ a unique technology of hot galvanizing our conduit threads. This new system provides two important benefits to the user. First, the zinc coating coverage is consistently uniform. Second, the threads are hot galvanized after the conduit is PVC coated. This means that nothing in the PVC coating process can damage the zinc coating on the threads, delivering a "virgin thread" to the user. These features offer much improved corrosion protection for the new threads. After hot galvanizing, we apply a clear urethane topcoat to ensure the threads remain corrosion free before and after installation.

APPROVAL STAMP

APPLICATION

FEATURES

COMPLIANCES



# PLASTI-BOND REDH<sub>2</sub>OT COATED CONDUIT AND NIPPLES

## Coated Conduit Technical Data

### COATED CONDUIT

| Metric Size Designators | Pipe Size Inches | Catalog Number   | Outside Wall Thickness Inches | Diameter With Coating Inches | Internal Inside Diameter Inches | Traverse Area Sq. Inches | Nominal Weight | Aluminum Catalog # |
|-------------------------|------------------|------------------|-------------------------------|------------------------------|---------------------------------|--------------------------|----------------|--------------------|
| 16                      | 1/2"             | PRHCONDUIT-1/2   | .104"                         | .920"                        | 0.632"                          | 0.314"                   | 85             | PRCONDUIT-AL-1/2   |
| 21                      | 3/4"             | PRHCONDUIT-3/4   | .107"                         | 1.130"                       | 0.836"                          | 0.549"                   | 112            | PRCONDUIT-AL-3/4   |
| 27                      | 1"               | PRHCONDUIT-1     | .126"                         | 1.395"                       | 1.063"                          | 0.887"                   | 164            | PRCONDUIT-AL-1     |
| 35                      | 1-1/4"           | PRHCONDUIT-1-1/4 | .133"                         | 1.740"                       | 1.394"                          | 1.526"                   | 217            | PRCONDUIT-AL-1-1/4 |
| 41                      | 1-1/2"           | PRHCONDUIT-1-1/2 | .138"                         | 1.980"                       | 1.624"                          | 2.071"                   | 268            | PRCONDUIT-AL-1-1/2 |
| 53                      | 2"               | PRHCONDUIT-2     | .146"                         | 2.455"                       | 2.083"                          | 3.408"                   | 358            | PRCONDUIT-AL-2     |
| 63                      | 2-1/2"           | PRHCONDUIT-2-1/2 | .193"                         | 2.955"                       | 2.489"                          | 4.866"                   | 546            | PRCONDUIT-AL-2-1/2 |
| 78                      | 3"               | PRHCONDUIT-3     | .205"                         | 3.580"                       | 3.090"                          | 7.499"                   | 708            | PRCONDUIT-AL-3     |
| 91                      | 3-1/2"           | PRHCONDUIT-3-1/2 | .215"                         | 4.080"                       | 3.570"                          | 10.010"                  | 851            | PRCONDUIT-AL-3-1/2 |
| 103                     | 4"               | PRHCONDUIT-4     | .225"                         | 4.580"                       | 4.050"                          | 12.882"                  | 1009           | PRCONDUIT-AL-4     |
| 129                     | 5"               | PRHCONDUIT-5     | .245"                         | 5.643"                       | 5.073"                          | 20.212"                  | 1337           | PRCONDUIT-AL-5     |
| 155                     | 6"               | PRHCONDUIT-6     | .266"                         | 6.705"                       | 6.093"                          | 29.158"                  | 1993           | PRCONDUIT-AL-6     |

### PLASTI-BOND REDH<sub>2</sub>OT COATED NIPPLES

#### APPLICATION

PLASTI-BOND REDH<sub>2</sub>OT factory threaded nipples save you time and money in the field. Electrical continuity is maintained across assembled joints.

\*The exteriors of certain short nipples are coated with urethane in lieu of PVC. This is dictated by the manufacturing process as well as assembly considerations.

#### FEATURES

- 40 mil gray PVC exterior coating
- 2 mil red urethane interior and thread coating
- 12 trade sizes from 1/2" through 6"
- 11 standard lengths in available: Close, 2" to 12"
- Made to order lengths available – Call for quote
- Plastic thread protector caps are color coded for quick identification of conduit size.

#### Thread Protector Cap Colors:

- Black- for 1/2" sizes, 1/2", 1-1/2", 2-1/2", 3-1/2"
- Red- for 1/4" sizes, 3/4", 1-1/4"
- Blue- for even sizes, 1", 2", 3", 4", 5", 6"

#### COMPLIANCES

#### Steel and Aluminum

- UL 6 (E2314); UL 6A (E98405)
- CSA C22.2 No. 45
- PVC as the primary corrosion protection for steel conduit. The underlying zinc coating is a supplemental corrosion protection coating. Restricted for use with threaded fittings only.

**ETL VERIFIED: Plasti-Bond Nipples are manufactured from ETL-verified conduit.**

### Simple Steps To Ordering

To order PLASTI-BOND coated nipples follow these simple steps to create a catalog number:

#### 1- Determine Proper Prefix.

- For steel conduit nipples use the prefix: **PRHNIP-**
- For aluminum conduit nipples use the prefix: **PRNIP-AL-**

#### 2- Add the conduit *trade size* needed to your catalog prefix. Example - 1/2" coated *steel* nipple: **PRHNIP-1/2**

#### 3- Enter an "X" to represent "by" as in "2X4". Example - **PRHNIP-1/2X**

#### 4- Enter the desired *nipple length*. Example - 10" **PRHNIP-1/2X10**

The catalog number for a Plasti-Bond coated steel, 1/2" nipple with a length of 10": **PRHNIP-1/2X10**

This number can then be looked up in the listing of pricing to determine price and availability.

Call 903-843-5591 for custom orders, customer service and more information on **Plasti-Bond REDH<sub>2</sub>OT**.

#### APPROVAL STAMP

(See online product submittal guide at [www.plastibond.com](http://www.plastibond.com))

# PLASTI-BOND REDH<sub>2</sub>OT COATED ELBOWS

## STANDARD RADIUS COATED ELBOWS

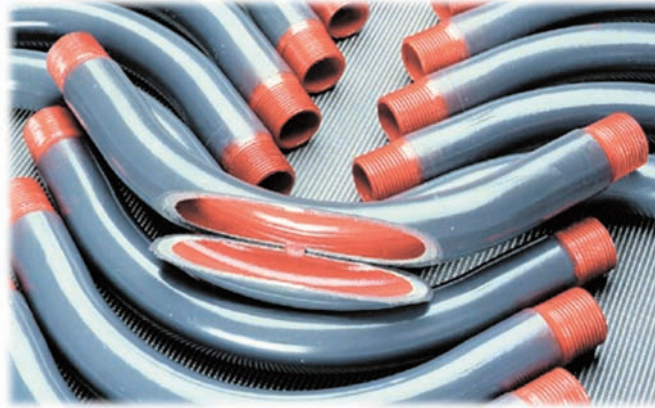

### Coated Elbow Specifications

PLASTI-BOND REDH<sub>2</sub>OT factory bent standard radius elbows are available and ready to ship. Factory bent elbows are more accurate, quicker to install and more economical, because they save field bending time and do not waste materials. Electrical continuity is maintained across assembled joints.

- 40 mil Gray PVC exterior coating
- 2 mil Red urethane interior and thread coating
- 12 trade sizes from 1/2" through 6"
- Available in 90°, 60°, 45°, and 30° bends
- Plastic thread protector caps are color coded for quick identification of conduit size.

#### Thread Protector Cap Colors:

- Black- for 1/2" sizes, 1/2", 1-1/2", 2-1/2", 3-1/2"
- Red- for 1/4" sizes, 3/4", 1-1/4"
- Blue- for even sizes, 1", 2", 3", 4", 5", 6"

#### Steel and Aluminum

- UL 6 (E2314); UL 6A (E98405)
- CSA C22.2 No. 45
- PVC as the primary corrosion protection for steel conduit. The underlying zinc coating is a supplemental corrosion protection coating. Restricted for use with threaded fittings only.

**ETL VERIFIED: Plasti-Bond Elbows are manufactured from ETL-verified conduit.**

### Simple Steps To Ordering

To order the PLASTI-BOND coated elbows follow these simple steps to creating a catalog number:

- 1- Determine Proper Prefix.**
  - For steel conduit elbow use the prefix: **PRHELB-**
  - For aluminum conduit elbow use the prefix: **PRELB-AL-**
- 2- Add the conduit trade size needed to your catalog prefix.**  
Example - 1/2" steel conduit elbow: **PRHELB-1/2**
- 3- Enter an "X" to represent "by" as in "2X4".**  
Example - **PRHELB-1/2X**
- 4- Enter the desired elbow degree of bend.**  
Example - 45°: **PRHELB-1/2X45**

For a coated steel, 1/2" elbow with a 45° bend, the catalog number would be: **PRHELB 1/2X45**

#### STEP 5 AND 6 FOR CONFIGURING CATALOG NUMBERS FOR LARGE RADIUS ELBOWS

- 5- Enter an "X" to represent "by" as in "2X4".**  
Example - **PRHELB-1/2X45X**
- 6- Enter the desired elbow radius.**  
Example - 30: **PRHELB-1/2X45X30**

For a coated steel, 1/2" elbow with a 45° bend, and a special radius of 30" the catalog number would be:  
**PRHELB-1/2X45X30**

This number can then be looked up in the listing of pricing to determine price and availability.

Call 903-843-5591 for custom orders, customer service and more information on **Plasti-Bond REDH<sub>2</sub>OT**.

#### APPROVAL STAMP

(See online product submittal guide at [www.plastibond.com](http://www.plastibond.com))



# STANDARD RADIUS COATED ELBOWS

## Dimensions

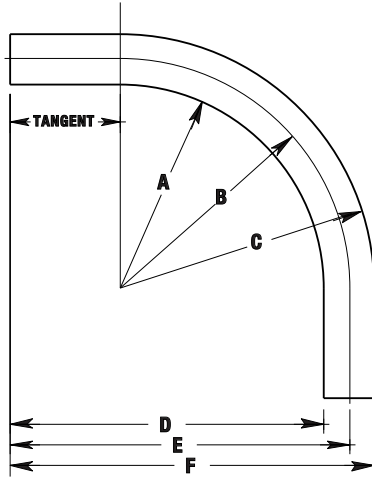

### Diagram Legend

- A = Radius at inside of bend.
- B = Radius at center line of bend.
- C = Radius at outside of bend.
- D = Offset at inside of bend.
- E = Offset at center of bend.
- F = Offset at outside of bend.

### STANDARD RADIUS ELBOWS

| Metric Size Designators | Nominal Size Inches | DIAMETERS       |                 | Nipple Lengths Inches | RADII    |                     |          | OFFSET   |          |          | Tangent Inches |
|-------------------------|---------------------|-----------------|-----------------|-----------------------|----------|---------------------|----------|----------|----------|----------|----------------|
|                         |                     | External Inches | Internal Inches |                       | A Inches | (standard) B Inches | C Inches | D Inches | E Inches | F Inches |                |
| 16                      | 1/2"                | 0.920"          | 0.632"          | 11-1/4"               | 3.79"    | 4.25"               | 4.71"    | 6.040"   | 6.500"   | 6.960"   | 2.250"         |
| 21                      | 3/4"                | 1.130"          | 0.836"          | 12-1/2"               | 3.94"    | 4.50"               | 5.07"    | 6.685"   | 7.250"   | 7.815"   | 2.750"         |
| 27                      | 1"                  | 1.395"          | 1.063"          | 14-3/4"               | 5.05"    | 5.75"               | 6.45"    | 7.928"   | 8.625"   | 9.323"   | 2.875"         |
| 35                      | 1-1/4"              | 1.740"          | 1.394"          | 17-3/4"               | 6.38"    | 7.25"               | 8.12"    | 9.567"   | 10.437"  | 11.307"  | 3.187"         |
| 41                      | 1-1/2"              | 1.980"          | 1.624"          | 19-3/4"               | 7.26"    | 8.25"               | 9.24"    | 10.635"  | 11.625"  | 12.615"  | 3.375"         |
| 53                      | 2"                  | 2.455"          | 2.083"          | 22-1/2"               | 8.27"    | 9.50"               | 10.73"   | 12.086"  | 13.313"  | 14.541"  | 3.813"         |
| 63                      | 2-1/2"              | 2.955"          | 2.489"          | 28"                   | 9.02"    | 10.50"              | 11.98"   | 14.776"  | 16.253"  | 17.731"  | 5.753"         |
| 78                      | 3"                  | 3.580"          | 3.080"          | 32"                   | 11.21"   | 13.00"              | 14.79"   | 17.000"  | 18.790"  | 20.580"  | 5.790"         |
| 91                      | 3-1/2"              | 4.080"          | 3.570"          | 39-1/2"               | 12.96"   | 15.00"              | 17.04"   | 20.920"  | 22.960"  | 25.000"  | 7.960"         |
| 103                     | 4"                  | 4.580"          | 4.050"          | 39-1/2"               | 13.71"   | 16.00"              | 18.29"   | 20.890"  | 23.180"  | 25.470"  | 7.180"         |
| 129                     | 5"                  | 5.643"          | 5.073"          | 59-1/2"               | 21.18"   | 24.00"              | 26.82"   | 32.079"  | 34.900"  | 37.722"  | 10.900"        |
| 155                     | 6"                  | 6.705"          | 6.093"          | 76"                   | 26.65"   | 30.00"              | 33.35"   | 41.088"  | 44.440"  | 47.793"  | 14.440"        |

PLASTI-BOND REDH<sub>2</sub>O<sub>T</sub> factory bent elbows are also available in larger than standard radii to accommodate your special needs. Simply follow the four steps for standard radius elbows on the previous page, then continue with Steps 5 and 6 for large radius elbows. Refer to the table below to determine which radius is available for the size of conduit you need.

To use the Large Radius Elbow table, find the elbow radius required in the first row. Then look down the column to determine which conduit sizes are available in that radius. *Use this information in Steps 5 and 6 on the previous page to build a catalog number.*

### LARGE RADIUS ELBOWS

| Radius B in Inches   | 12"      | 15"      | 18"    | 18"          | 24"        | 24"          | 30"      | 30"      | 36"        | 36"       | 36"      | 42"  | 42"     | 42"      | 48"          | 48"      | 48"      |
|----------------------|----------|----------|--------|--------------|------------|--------------|----------|----------|------------|-----------|----------|------|---------|----------|--------------|----------|----------|
| E Offset             | 1'5-1/2" | 1'9-1/4" | 2'1/4" | 2'3"         | 2'8"       | 2'10"        | 3'4"     | 3'5"     | 3'11"      | 3'11-1/4" | 4'3-1/4" | 4'5" | 4'6"    | 4'9-1/2" | 5'1/4"       | 5'1-1/4" | 5'3-1/4" |
| Nipple Length        | 2'6"     | 3'0"     | 3'5"   | 3'10"        | 4'6"       | 4'9"         | 5'6"     | 5'9"     | 6'7"       | 6'7"      | 7'3"     | 7'4" | 7'6"    | 8'1"     | 8'4"         | 8'6"     | 8'10"    |
| Tangent              | 5-1/2"   | 6-1/4"   | 6-1/4" | 9"           | 8"         | 10"          | 10"      | 11"      | 11"        | 11-1/4"   | 15-1/4"  | 11"  | 12"     | 15-1/2"  | 12-1/4"      | 13-1/4"  | 15-1/4"  |
| Available Pipe Sizes | 1" & 2"  | 2"       | 1"     | 1-1/2" to 3" | 3/4" to 2" | 2-1/2" to 5" | 2" to 3" | 4" to 6" | 3/4" to 4" | 5" only   | 6" only  | 4"   | 5" only | n/a      | 1-1/2" to 4" | 5" only  | 6" only  |

# PLASTI-BOND REDH<sub>2</sub>O<sup>T</sup> PULLING ELBOWS

## PULLING ELBOWS

### Pulling Elbows Specifications



PRLBD2200

#### APPLICATION

PLASTI-BOND REDH<sub>2</sub>O<sup>T</sup> LBD conduit bodies are used at 90° bends in conduit runs to allow straight pulls at bends, to serve as pull outlets for stiff conductors, to allow for service entrance into buildings or to allow conductor entrance into motors. Electrical continuity of the conduit system is maintained across assembled joints.

#### FEATURES

- 40 mil gray PVC exterior coating
- 2 mil red urethane interior coating
- 10 trade sizes from 1/2" through 4"
- Sealing sleeves on all conduit openings
- Molded-in seal between body and cover
- Domed covers allow gentle bends of conductors
- Shipped with covers
- Angled covers allow straight pulling in either direction

#### COMPLIANCES

- Steel Fittings Only**
- UL 514B (E200413)

### Pulling Elbows Technical Data

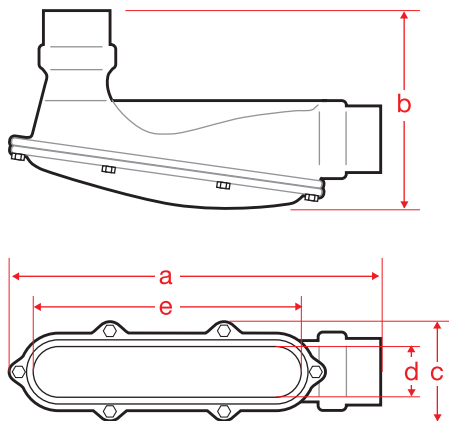

#### PULLING ELBOWS LBD

| Pipe Size | FERROUS CATALOG # | Nominal Weight | A     | B     | C    | D    | E     | ALUMINUM CATALOG # |
|-----------|-------------------|----------------|-------|-------|------|------|-------|--------------------|
| 1/2"      | PRLBD1100         | 1.2            | 5.54  | 2.85  | 1.39 | 1.00 | 3.34  | PRLBD1100SA        |
| 3/4"      | PRLBD2200         | 2.0            | 7.04  | 3.42  | 1.64 | 1.25 | 4.53  | PRLBD2200SA        |
| 1"        | PRLBD3300         | 2.5            | 7.29  | 3.98  | 1.89 | 1.50 | 4.34  | PRLBD3300SA        |
| 1-1/4"    | PRLBD4400         | 6.0            | 9.92  | 5.54  | 3.58 | 1.81 | 7.19  | PRLBD4400SA        |
| 1-1/2"    | PRLBD5500         | 11.5           | 13.98 | 6.98  | 4.71 | 2.63 | 10.88 | PRLBD5500SA        |
| 2"        | PRLBD6600         | 18.0           | 14.48 | 7.48  | 4.71 | 2.63 | 10.88 | PRLBD6600SA        |
| 2-1/2"    | PRLBD7700         | 22.0           | 21.73 | 11.60 | 5.71 | 3.00 | 15.75 | PRLBD7700SA        |
| 3"        | PRLBD8800         | 35.0           | 21.73 | 11.60 | 5.71 | 3.00 | 15.75 | PRLBD8800SA        |
| 3-1/2"    | PRLBD9900         | 60.0           | 29.85 | 13.92 | 7.21 | 4.00 | 24.00 | PRLBD9900SA        |
| 4"        | PRLBD10900        | 70.0           | 29.85 | 13.92 | 7.21 | 4.00 | 24.00 | PRLBD10900SA       |

#### APPROVAL STAMP

(See online product submittal guide at [www.plastibond.com](http://www.plastibond.com))



# PLASTI-BOND REDH<sub>2</sub>O<sub>T</sub> CONDUIT THREAD AND COUPLING

## COATED COUPLINGS

### Thread and Coupling Specifications

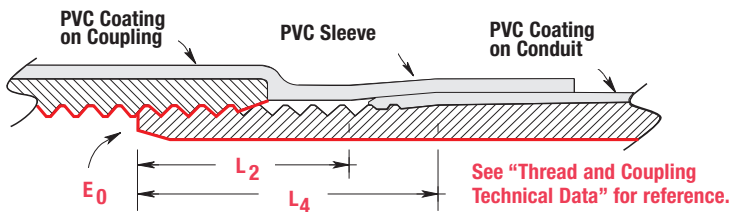

All female pipe openings are provided with a PVC sleeve sized to fit tightly over the PVC coated conduit when assembled. This prevents corrosives from contacting threaded joints.

#### APPLICATION

PVC coated rigid metal conduit couplings with red urethane interior coating connects coated conduit sections. Electrical continuity is maintained across assembled joints. PVC sleeves on couplings seal off on conduit PVC coating when assembled to prevent corrosive liquids and vapors from attacking threaded joints.

#### FEATURES

- 40 mil gray PVC exterior coating
- 2 mil red urethane interior coating over galvanized threads
- 12 trade sizes from 1/2" through 6"
- Sealing sleeves on both ends
- Molded external ribs on 1/2" – 4" to prevent tool damage during assembly
- Couplings are straight tapped

#### COMPLIANCES

##### Steel and Aluminum

- UL 6 (E2314); UL 6A (E98405)
- CSA C22.2 No. 45

### Thread and Coupling Technical Data

#### COUPLING

#### THREADS

| Metric Size Designators | Pipe Size Inches | Steel Catalog # | Nominal Weight Per 100 (Pounds) | Outside Diameter With Ribs Inches | Threads Per Inch | Effective Length $L_2$ | Total Length of Threads to Vanish Point $L_4$ | Pitch At End of Thread 3/4 in. Taper $E_0$ | Aluminum Catalog # |
|-------------------------|------------------|-----------------|---------------------------------|-----------------------------------|------------------|------------------------|-----------------------------------------------|--------------------------------------------|--------------------|
| 16                      | 1/2"             | PRCPLG-1/2      | 19                              | 1.344"                            | 14               | .5337"                 | .7815"                                        | .7584"                                     | PRCPLG-AL-1/2      |
| 21                      | 3/4"             | PRCPLG-3/4      | 32                              | 1.531"                            | 14               | .5457"                 | .7935"                                        | .9677"                                     | PRCPLG-AL-3/4      |
| 27                      | 1"               | PRCPLG-1        | 40                              | 1.781"                            | 11-1/2           | .6828"                 | .9845"                                        | 1.2136"                                    | PRCPLG-AL-1        |
| 35                      | 1-1/4"           | PRCPLG-1-1/4    | 50                              | 2.156"                            | 11-1/2           | .7068"                 | 1.0085"                                       | 1.5571"                                    | PRCPLG-AL-1-1/4    |
| 41                      | 1-1/2"           | PRCPLG-1-1/2    | 69                              | 2.469"                            | 11-1/2           | .7235"                 | 1.0252"                                       | 1.7961"                                    | PRCPLG-AL-1-1/2    |
| 53                      | 2"               | PRCPLG-2        | 93                              | 2.969"                            | 11-1/2           | .7565"                 | 1.0582"                                       | 2.2690"                                    | PRCPLG-AL-2        |
| 63                      | 2-1/2"           | PRCPLG-2-1/2    | 123                             | 3.594"                            | 8                | 1.1375"                | 1.5712"                                       | 2.7195"                                    | PRCPLG-AL-2-1/2    |
| 78                      | 3"               | PRCPLG-3        | 217                             | 4.250"                            | 8                | 1.2000"                | 1.6337"                                       | 3.3406"                                    | PRCPLG-AL-3        |
| 91                      | 3-1/2"           | PRCPLG-3-1/2    | 422                             | 4.875"                            | 8                | 1.2500"                | 1.6837"                                       | 3.8375"                                    | PRCPLG-AL-3-1/2    |
| 103                     | 4"               | PRCPLG-4        | 391                             | 5.250"                            | 8                | 1.3000"                | 1.7337"                                       | 4.3344"                                    | PRCPLG-AL-4        |
| 129                     | 5"               | PRCPLG-5        | 550                             | 6.080"                            | 8                | 1.4063"                | 1.8400"                                       | 5.3907"                                    | PRCPLG-AL-5        |
| 155                     | 6"               | PRCPLG-6        | 884                             | 7.280"                            | 8                | 1.5125"                | 1.9462"                                       | 6.4461"                                    | PRCPLG-AL-6        |

Couplings are straight tapped.

Tolerance, thread length  $\pm 1$  thread.

Plus or minus 1 turn is the maximum variation permitted from the gauging face of the working thread gauges.

This is equivalent to plus or minus 1 and 1-1/2 turns from the basic dimensions, since the variation of plus or minus 1/2 turn from basic dimension is permitted in working gauges.

#### APPROVAL STAMP

(See online product submittal guide at [www.plastibond.com](http://www.plastibond.com))

# PLASTI-BOND REDH<sub>2</sub>OT CONDUIT BODIES

## CONDUIT BODIES AND COVERS FOR GENERAL SERVICE LOCATIONS



PRHLB28



PRHLR28

### Conduit Bodies Specifications

PLASTI-BOND REDH<sub>2</sub>OT conduit bodies with covers are offered in Form 8 and Form 7 styles, each with numerous configurations to provide a complete coated conduit system. May be used to make 90° bends, for pull outlets, to provide for taps or splices, to act as a mounting outlet for wiring devices or lighting fixtures etc.. Form 8 style fittings 1/2" – 2" have an integral V-Seal gasket for superior corrosion protection. Electrical continuity of the conduit system is maintained across assembled joints.

- 40 mil gray PVC exterior coating
- 2 mil red urethane internal coating
- 10 trade sizes from 1/2" through 4"
- Sealing sleeves on all conduit openings
- Form 7 style cover uses retained stainless screw and wedge clip design
- Form 8 style cover uses plastic encapsulated stainless steel screws with retainers built into covers for trade sizes 1/2" through 2".
- Integral V-Seal gasket on Form 8 style, sizes 1/2" through 2"

#### Steel and Aluminum

- UL 514A, 514D (E231035)
- CSA C22.2 No. 18, CSA C22.2 No. 42

*Note: Form 7 fittings are not available with encapsulated screws. All cover screws are stainless steel.*

#### APPROVAL STAMP

(See online product submittal guide at [www.plastibond.com](http://www.plastibond.com))

### Conduit Bodies Technical Data

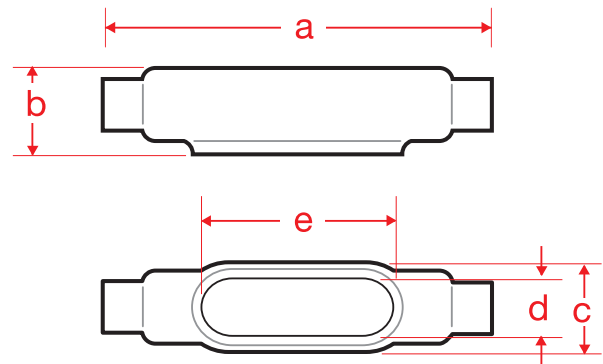

#### C FORM 8

#### MARK 9

| Pipe Size | FERROUS CATALOG # | Nominal Weight | A     | B    | C    | D    | E     | ALUMINUM CATALOG # |
|-----------|-------------------|----------------|-------|------|------|------|-------|--------------------|
| 1/2"      | PRHC18            | 2.0            | 6.69  | 1.48 | 1.46 | 1.00 | 3.31  | PRC19              |
| 3/4"      | PRHC28            | 2.3            | 7.78  | 1.73 | 1.27 | 1.19 | 3.94  | PRC29              |
| 1"        | PRHC38            | 2.8            | 9.31  | 1.98 | 1.83 | 1.38 | 4.56  | PRC39              |
| 1-1/4"    | PRHC448           | 4.5            | 11.00 | 2.42 | 2.27 | 1.75 | 5.31  | PRC49              |
| 1-1/2"    | PRHC58            | 6.5            | 13.38 | 2.82 | 2.83 | 2.13 | 6.50  | PRC59              |
| 2"        | PRHC68            | 10.3           | 14.25 | 3.60 | 3.83 | 3.00 | 8.56  | PRC69              |
| 2-1/2"    | PRC78             | 18.0           | 17.63 | 4.48 | 5.08 | 4.25 | 10.88 | PRC789             |
| 3"        | PRC88             | 20.5           | 17.63 | 4.85 | 5.08 | 4.25 | 10.88 | PRC889             |
| 3-1/2"    | PRC989            | 10.0           | 20.75 | 5.73 | 6.33 | 5.44 | 13.44 | PRC989             |
| 4"        | PRC1089           | 12.0           | 20.75 | 5.73 | 6.33 | 5.44 | 13.44 | PRC1089            |

#### C FORM 7

| Pipe Size | FERROUS CATALOG # | Nominal Weight | A     | B    | C    | D    | E    | ALUMINUM CATALOG # |
|-----------|-------------------|----------------|-------|------|------|------|------|--------------------|
| 1/2"      | PRC17             | 1.0            | 6.38  | 1.42 | 1.46 | 0.94 | 3.19 | PRC17SA            |
| 3/4"      | PRC27             | 1.4            | 7.50  | 1.67 | 1.64 | 1.13 | 3.81 | PRC27SA            |
| 1"        | PRC37             | 2.2            | 9.00  | 1.92 | 1.83 | 1.38 | 4.50 | PRC37SA            |
| 1-1/4"    | PRC47             | 2.7            | 9.94  | 2.35 | 2.27 | 1.75 | 5.00 | PRC47SA            |
| 1-1/2"    | PRC57             | 4.0            | 11.19 | 2.60 | 2.52 | 1.94 | 5.44 | PRC57SA            |
| 2"        | PRC67             | 5.5            | 11.19 | 3.17 | 3.08 | 2.44 | 6.38 | PRC67SA            |
| 2-1/2"    | PRC77             | 10.0           | 14.00 | 3.67 | 4.33 | 3.56 | 8.38 | PRC77SA            |
| 3"        | PRC87             | 11.8           | 13.75 | 4.42 | 4.33 | 3.56 | 8.38 | PRC87SA            |

# CONDUIT BODIES AND COVERS FOR GENERAL SERVICE LOCATIONS

## Conduit Bodies Technical Data

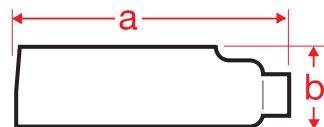
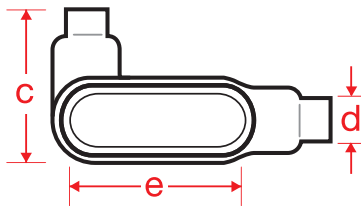
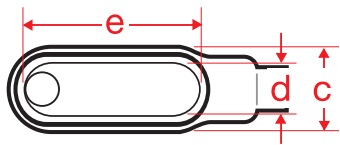
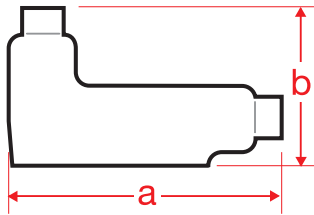

### LB FORM 8

### MARK 9

| Pipe Size | FERROUS CATALOG # | Nominal Weight | A     | B    | C    | D    | E     | ALUMINUM CATALOG # |
|-----------|-------------------|----------------|-------|------|------|------|-------|--------------------|
| 1/2"      | PRHLB18           | 1.5            | 5.48  | 2.26 | 1.42 | 1.00 | 3.31  | PRLB19             |
| 3/4"      | PRHLB28           | 2.0            | 6.35  | 2.48 | 1.60 | 1.19 | 3.94  | PRLB29             |
| 1"        | PRHLB38           | 2.9            | 7.51  | 2.85 | 1.79 | 1.38 | 4.56  | PRLB39             |
| 1-1/4"    | PRHLB448          | 4.1            | 8.82  | 3.38 | 2.23 | 1.75 | 5.31  | PRLB49             |
| 1-1/2"    | PRHLB58           | 6.5            | 10.67 | 4.07 | 2.79 | 2.13 | 6.50  | PRLB59             |
| 2"        | PRHLB68           | 8.2            | 13.04 | 4.85 | 3.79 | 3.00 | 8.56  | PRLB69             |
| 2-1/2"    | PRLB78            | 18.2           | 15.98 | 6.17 | 5.04 | 4.25 | 10.88 | PRLB789            |
| 3"        | PRLB888           | 21.2           | 15.98 | 6.54 | 5.04 | 4.25 | 10.88 | PRLB889            |
| 3-1/2"    | PRLB98            | 31.2           | 18.92 | 7.60 | 6.29 | 5.44 | 13.44 | PRLB989            |
| 4"        | PRLB108           | 32.0           | 18.92 | 7.85 | 6.29 | 5.44 | 13.44 | PRLB1089           |

### LB FORM 7

| Pipe Size | FERROUS CATALOG # | Nominal Weight | A     | B    | C    | D    | E     | ALUMINUM CATALOG # |
|-----------|-------------------|----------------|-------|------|------|------|-------|--------------------|
| 1/2"      | PRLB17            | 1.1            | 5.10  | 2.29 | 1.42 | 0.94 | 3.19  | PRLB17SA           |
| 3/4"      | PRLB27            | 1.7            | 5.98  | 2.54 | 1.6  | 1.13 | 3.81  | PRLB27SA           |
| 1"        | PRLB37            | 2.2            | 7.04  | 2.92 | 1.79 | 1.38 | 4.50  | PRLB37SA           |
| 1-1/4"    | PRLB47            | 3.1            | 7.79  | 3.35 | 2.23 | 1.75 | 5.00  | PRLB47SA           |
| 1-1/2"    | PRLB57            | 3.8            | 8.67  | 3.73 | 2.48 | 1.94 | 5.44  | PRLB57SA           |
| 2"        | PRLB67            | 5.2            | 10.17 | 4.29 | 3.04 | 2.44 | 6.38  | PRLB67SA           |
| 2-1/2"    | PRLB777           | 10.0           | 12.54 | 5.17 | 4.29 | 3.56 | 8.38  | PRLB777SA          |
| 3"        | PRLB87            | 13.0           | 12.54 | 5.92 | 4.29 | 3.56 | 8.38  | PRLB87SA           |
| 3-1/2"    | PRLB97            | 19.0           | 14.73 | 6.60 | 5.29 | 4.50 | 10.25 | PRLB97SA           |
| 4"        | PRLB107           | 18.5           | 14.73 | 7.10 | 5.29 | 4.50 | 10.25 | PRLB107SA          |

### LL FORM 8

### MARK 9

| Pipe Size | FERROUS CATALOG # | Nominal Weight | A     | B    | C    | D    | E     | ALUMINUM CATALOG # |
|-----------|-------------------|----------------|-------|------|------|------|-------|--------------------|
| 1/2"      | PRLL18            | 1.4            | 5.48  | 1.48 | 2.20 | 1.00 | 3.31  | PRLL19             |
| 3/4"      | PRLL28            | 2.1            | 6.35  | 1.73 | 2.35 | 1.19 | 3.94  | PRLL29             |
| 1"        | PRLL38            | 2.6            | 7.51  | 1.98 | 2.67 | 1.38 | 4.56  | PRLL39             |
| 1-1/4"    | PRLL448           | 4.2            | 8.82  | 2.42 | 3.20 | 1.75 | 5.31  | PRLL49             |
| 1-1/2"    | PRLL58            | 6.2            | 10.67 | 2.82 | 4.04 | 2.13 | 6.50  | PRLL59             |
| 2"        | PRLL68            | 10.5           | 13.04 | 3.60 | 5.04 | 3.00 | 8.56  | PRLL69             |
| 2-1/2"    | PRLL78            | 19.0           | 15.98 | 4.48 | 6.73 | 4.25 | 10.88 | PRLL789            |
| 3"        | PRLL888           | 21.5           | 15.98 | 4.85 | 6.73 | 4.25 | 10.88 | PRLL889            |
| 3-1/2"    | PRLL98            | 21.5           | 14.73 | 4.92 | 6.98 | 4.50 | 10.25 | PRLL989            |
| 4"        | PRLL1089          | 24.5           | 14.73 | 5.42 | 6.98 | 4.50 | 10.25 | PRLL1089           |

### LL FORM 7

| Pipe Size | FERROUS CATALOG # | Nominal Weight | A     | B    | C    | D    | E     | ALUMINUM CATALOG # |
|-----------|-------------------|----------------|-------|------|------|------|-------|--------------------|
| 1/2"      | PRLL17            | 1.2            | 5.1   | 1.42 | 2.29 | 0.94 | 3.19  | PRLL17SA           |
| 3/4"      | PRLL27            | 1.6            | 5.98  | 1.67 | 2.48 | 1.13 | 3.81  | PRLL27SA           |
| 1"        | PRLL37            | 2.1            | 7.04  | 1.92 | 2.79 | 1.38 | 4.50  | PRLL37SA           |
| 1-1/4"    | PRLL47            | 3.0            | 7.79  | 2.35 | 3.23 | 1.75 | 5.00  | PRLL47SA           |
| 1-1/2"    | PRLL57            | 4.1            | 8.67  | 2.60 | 3.60 | 1.94 | 5.44  | PRLL57SA           |
| 2"        | PRLL67            | 5.7            | 10.17 | 3.17 | 4.17 | 2.44 | 6.38  | PRLL67SA           |
| 2-1/2"    | PRLL777           | 10.0           | 12.54 | 3.67 | 5.79 | 3.56 | 8.38  | PRLL777SA          |
| 3"        | PRLL87            | 12.7           | 12.54 | 4.42 | 5.79 | 3.56 | 8.38  | PRLL87SA           |
| 3-1/2"    | PRLL97            | 19.0           | 14.73 | 4.92 | 6.98 | 4.50 | 10.25 | PRLL97SA           |
| 4"        | PRLL107           | 19.0           | 14.73 | 5.42 | 6.98 | 4.50 | 10.25 | PRLL107SA          |



# PLASTI-BOND REDH<sub>2</sub>O<sub>T</sub> CONDUIT BODIES

## CONDUIT BODIES AND COVERS FOR GENERAL SERVICE LOCATIONS

### Conduit Bodies Technical Data

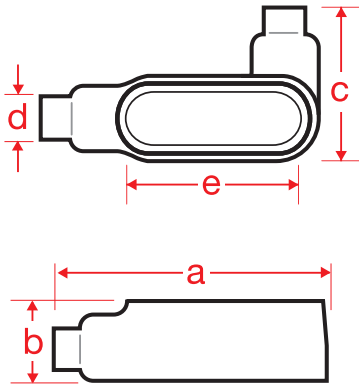

#### LR FORM 8

| Pipe Size | FERROUS CATALOG # | Nominal Weight | A     | B    | C    | D    | E     | ALUMINUM CATALOG # |
|-----------|-------------------|----------------|-------|------|------|------|-------|--------------------|
| 1/2"      | PRHLR18           | 1.4            | 5.48  | 1.48 | 2.20 | 1.00 | 3.31  | PRLR19             |
| 3/4"      | PRHLR28           | 2.1            | 6.35  | 1.73 | 2.35 | 1.19 | 3.94  | PRLR29             |
| 1"        | PRHLR38           | 2.6            | 7.51  | 1.98 | 2.67 | 1.38 | 4.56  | PRLR39             |
| 1-1/4"    | PRHLR448          | 4.5            | 8.82  | 2.42 | 3.20 | 1.75 | 5.31  | PRLR49             |
| 1-1/2"    | PRHLR58           | 6.2            | 10.67 | 2.82 | 4.04 | 2.13 | 6.50  | PRLR59             |
| 2"        | PRHLR68           | 10.7           | 13.04 | 3.60 | 5.04 | 3.00 | 8.56  | PRLR69             |
| 2-1/2"    | PRLR78            | 17.7           | 15.98 | 4.48 | 6.73 | 4.25 | 10.88 | PRLR789            |
| 3"        | PRLR888           | 18.0           | 15.98 | 4.85 | 6.73 | 4.25 | 10.88 | PRLR889            |
| 3-1/2"    | PRLR989           | 21.0           | 14.73 | 4.92 | 6.98 | 4.50 | 10.25 | PRLR989            |
| 4"        | PRLR1089          | 24.0           | 14.73 | 5.42 | 6.98 | 4.50 | 10.25 | PRLR1089           |

#### LR FORM 7

| Pipe Size | FERROUS CATALOG # | Nominal Weight | A     | B    | C    | D    | E     | ALUMINUM CATALOG # |
|-----------|-------------------|----------------|-------|------|------|------|-------|--------------------|
| 1/2"      | PRLR17            | 1.2            | 5.10  | 1.42 | 2.29 | 0.94 | 3.19  | PRLR17SA           |
| 3/4"      | PRLR27            | 1.6            | 5.98  | 1.67 | 2.48 | 1.13 | 3.81  | PRLR27SA           |
| 1"        | PRLR37            | 2.1            | 7.04  | 1.92 | 2.79 | 1.38 | 4.50  | PRLR37SA           |
| 1-1/4"    | PRLR47            | 3.0            | 7.79  | 2.35 | 3.23 | 1.75 | 5.00  | PRLR47SA           |
| 1-1/2"    | PRLR57            | 4.1            | 8.67  | 2.60 | 3.60 | 1.94 | 5.44  | PRLR57SA           |
| 2"        | PRLR67            | 5.7            | 10.17 | 3.17 | 4.17 | 2.44 | 6.38  | PRLR67SA           |
| 2-1/2"    | PRLR777           | 10.0           | 12.54 | 3.67 | 5.79 | 3.56 | 8.38  | PRLR777SA          |
| 3"        | PRLR87            | 12.7           | 12.54 | 4.42 | 5.79 | 3.56 | 8.38  | PRLR87SA           |
| 3-1/2"    | PRLR97            | 19.0           | 14.73 | 4.92 | 6.98 | 4.50 | 10.25 | PRLR97SA           |
| 4"        | PRLR107           | 19.0           | 14.73 | 5.42 | 6.98 | 4.50 | 10.25 | PRLR107SA          |



PRHT28



PRT27



Form 8 & Form 7 Covers

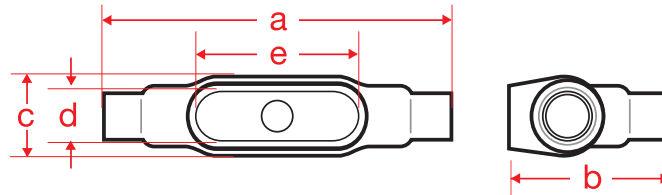

#### TB FORM 8

#### MARK 9

| Pipe Size | FERROUS CATALOG # | Nominal Weight | A     | B    | C    | D    | E    | ALUMINUM CATALOG # |
|-----------|-------------------|----------------|-------|------|------|------|------|--------------------|
| 1/2"      | PRHTB18           | 2.0            | 6.69  | 3.57 | 1.46 | 1.00 | 3.31 | PRTB19             |
| 3/4"      | PRHTB28           | 2.3            | 7.78  | 3.79 | 1.64 | 1.19 | 3.94 | PRTB29             |
| 1"        | PRHTB38           | 3.1            | 9.31  | 4.17 | 1.83 | 1.38 | 4.56 | PRTB39             |
| 1-1/4"    | PRHTB448          | 5.2            | 11.00 | 4.38 | 2.27 | 1.75 | 5.31 | -                  |
| 1-1/2"    | PRHTB58           | 7.0            | 13.38 | 5.07 | 2.83 | 2.13 | 6.50 | -                  |
| 2"        | PRHTB68           | 11.0           | 16.25 | 5.85 | 3.83 | 3.00 | 8.56 | -                  |

#### TB FORM 7

| Pipe Size | FERROUS CATALOG # | Nominal Weight | A     | B    | C    | D    | E    | ALUMINUM CATALOG # |
|-----------|-------------------|----------------|-------|------|------|------|------|--------------------|
| 1/2"      | PRTB17            | 1.6            | 6.63  | 2.67 | 1.64 | 0.94 | 3.19 | PRTB19             |
| 3/4"      | PRTB27            | 2.1            | 7.75  | 2.92 | 1.83 | 1.13 | 3.81 | PRTB29             |
| 1"        | PRTB37            | 2.7            | 9.25  | 3.29 | 2.08 | 1.38 | 4.50 | PRTB39             |
| 1-1/4"    | PRTB47            | 3.7            | 9.94  | 3.35 | 2.27 | 1.75 | 5.00 | -                  |
| 1-1/2"    | PRTB57            | 4.7            | 11.19 | 5.04 | 2.52 | 1.94 | 5.44 | -                  |
| 2"        | PRTB67            | 7.0            | 13.19 | 6.17 | 3.08 | 2.44 | 6.38 | -                  |

# CONDUIT BODIES FOR GENERAL SERVICE LOCATIONS

## Conduit Bodies Technical Data

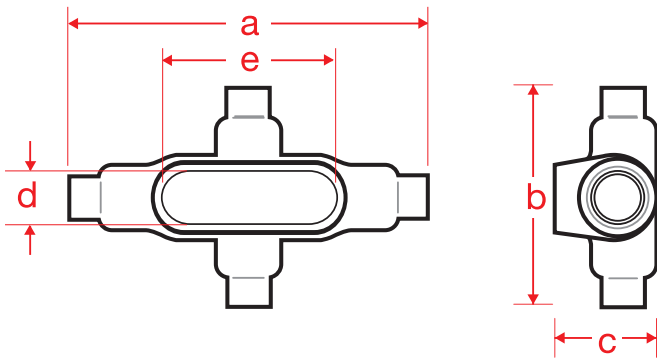

### X FORM 8

### MARK 9

| Pipe Size | FERROUS CATALOG # | Nominal Weight | A     | B     | C    | D    | E    | ALUMINUM CATALOG # |
|-----------|-------------------|----------------|-------|-------|------|------|------|--------------------|
| 1/2"      | PRHX18            | 2.0            | 6.69  | 3.91  | 1.79 | 1.00 | 3.31 | PRX19              |
| 3/4"      | PRHX28            | 2.6            | 7.78  | 4.56  | 2.04 | 1.19 | 3.94 | PRX29              |
| 1"        | PRHX38            | 3.1            | 9.31  | 5.50  | 2.29 | 1.38 | 4.56 | PRX39              |
| 1-1/4"    | PRHX448           | 5.2            | 11.00 | 6.63  | 2.67 | 1.75 | 5.31 | -                  |
| 1-1/2"    | PRHX58            | 7.5            | 13.38 | 8.25  | 2.51 | 2.13 | 6.50 | -                  |
| 2"        | PRHX68            | 11.7           | 16.25 | 10.25 | 3.60 | 3.00 | 8.56 | -                  |

### X FORM 7

| Pipe Size | FERROUS CATALOG # | Nominal Weight | A     | B    | C    | D    | E    | ALUMINUM CATALOG # |
|-----------|-------------------|----------------|-------|------|------|------|------|--------------------|
| 1/2"      | PRX17             | 1.7            | 6.63  | 3.35 | 1.79 | 0.94 | 3.19 | PRX1SA             |
| 3/4"      | PRX27             | 2.4            | 7.75  | 3.54 | 2.04 | 1.13 | 3.81 | PRX2SA             |
| 1"        | PRX37             | 2.7            | 9.25  | 4.04 | 2.29 | 1.38 | 4.50 | PRX3SA             |
| 1-1/4"    | PRX47             | 3.6            | 9.94  | 4.17 | 2.35 | 1.75 | 5.00 | -                  |
| 1-1/2"    | PRX57             | 5.0            | 11.19 | 4.67 | 2.60 | 1.94 | 5.44 | -                  |
| 2"        | PRX67             | 7.5            | 13.19 | 5.23 | 3.17 | 2.44 | 6.38 | -                  |

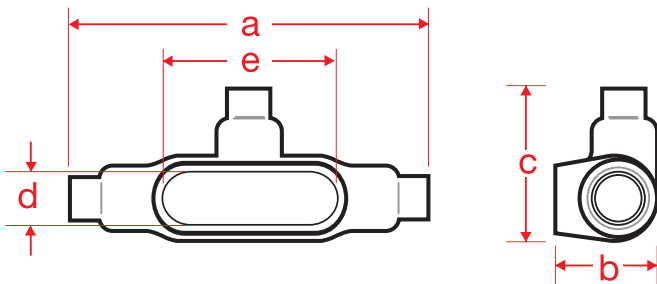

### T FORM 8

### MARK 9

| Pipe Size | FERROUS CATALOG # | Nominal Weight | A     | B    | C    | D    | E     | ALUMINUM CATALOG # |
|-----------|-------------------|----------------|-------|------|------|------|-------|--------------------|
| 1/2"      | PRHT18            | 1.8            | 6.69  | 1.79 | 2.20 | 1.00 | 3.31  | PRT19              |
| 3/4"      | PRHT28            | 2.5            | 7.78  | 2.04 | 2.35 | 1.19 | 3.94  | PRT29              |
| 1"        | PRHT38            | 3.3            | 9.31  | 2.29 | 2.67 | 1.38 | 4.56  | PRT39              |
| 1-1/4"    | PRHT448           | 4.9            | 11.00 | 2.67 | 3.20 | 1.75 | 5.31  | PRT49              |
| 1-1/2"    | PRHT58            | 7.5            | 13.38 | 2.82 | 4.04 | 2.13 | 6.50  | PRT59              |
| 2"        | PRHT68            | 11.7           | 16.25 | 3.60 | 5.04 | 3.00 | 8.56  | PRT69              |
| 2-1/2"    | PRT78             | 19.8           | 19.63 | 4.48 | 6.73 | 4.25 | 10.88 | PRT789             |
| 3"        | PRT88             | 23.5           | 19.63 | 4.85 | 6.73 | 4.25 | 10.88 | PRT889             |
| 3-1/2"    | PRT989            | 21.0           | 22.75 | 5.73 | 8.17 | 5.44 | 13.44 | PRT989             |
| 4"        | PRT1089           | 24.0           | 22.75 | 5.98 | 8.17 | 5.44 | 13.44 | PRT1089            |

### REPLACEMENT SCREW KITS

| CATALOG #      | Description                 |
|----------------|-----------------------------|
| PBSCREW-KIT-1  | 1/2-3/4 FORM 8 ENCAP SCREWS |
| PBSCREW-KIT-2  | 1-1 1/4 FORM 8 ENCAP SCREWS |
| PBSCREW-KIT-3  | 1 1/2 FORM 8 ENCAP SCREWS   |
| PBSCREW-KIT-4  | 2 FORM 8 ENCAP SCREWS       |
| PBSCREW-KIT-5  | 2 1/2-3 FORM 8 ENCAP SCREWS |
| PBSCREW-KIT-6  | 3 1/2-4 FORM 8 ENCAP SCREWS |
| PBSCREW-KIT-7  | 1/2 OE ENCAP SCREWS         |
| PBSCREW-KIT-8  | 3/4 OE ENCAP SCREWS         |
| PBSCREW-KIT-9  | 1 1/4 LBD ENCAP SCREWS      |
| PBSCREW-KIT-10 | 1 1/2 LBD ENCAP SCREWS      |
| PBSCREW-KIT-11 | 2 LBD ENCAP SCREWS          |
| PBSCREW-KIT-12 | 2 1/2-3 LBD ENCAP SCREWS    |
| PBSCREW-KIT-13 | 2 1/2-3 MARK 9 ENCAP SCREWS |
| PBSCREW-KIT-14 | 3 1/2-4 MARK 9 ENCAP SCREWS |

### T FORM 7

| Pipe Size | FERROUS CATALOG # | Nominal Weight | A     | B    | C    | D    | E     | ALUMINUM CATALOG # |
|-----------|-------------------|----------------|-------|------|------|------|-------|--------------------|
| 1/2"      | PRT17             | 1.5            | 6.63  | 1.79 | 2.48 | 0.94 | 3.19  | PRT17SA            |
| 3/4"      | PRT27             | 2.1            | 7.75  | 2.04 | 2.67 | 1.13 | 3.81  | PRT27SA            |
| 1"        | PRT37             | 2.9            | 9.25  | 2.29 | 3.04 | 1.38 | 4.50  | PRT37SA            |
| 1-1/4"    | PRT47             | 3.6            | 9.94  | 2.35 | 3.23 | 1.75 | 5.00  | PRT47SA            |
| 1-1/2"    | PRT57             | 4.5            | 11.19 | 2.60 | 3.60 | 1.94 | 5.44  | PRT57SA            |
| 2"        | PRT67             | 6.5            | 13.19 | 3.17 | 4.17 | 2.44 | 6.38  | PRT67SA            |
| 2-1/2"    | PRT77             | 10.7           | 16.00 | 3.67 | 5.79 | 3.56 | 8.38  | PRT77SA            |
| 3"        | PRT87             | 15.4           | 16.06 | 4.42 | 5.79 | 3.56 | 8.38  | PRT87SA            |
| 3-1/2"    | PRT97             | 19.0           | 18.31 | 4.92 | 6.98 | 4.50 | 10.25 | PRT97SA            |
| 4"        | PRT107            | 21.0           | 18.31 | 5.42 | 6.98 | 4.50 | 10.25 | PRT107SA           |

# PLASTI-BOND REDH<sub>2</sub>O<sub>T</sub> CONDUIT BODIES

## CONDUIT BODIES AND COVERS FOR GENERAL SERVICE LOCATIONS



PRBUB3

PRBG48 Cover (cover sold separately)

### Mogul Style Conduit Bodies Specifications

PLASTI-BOND REDH<sub>2</sub>O<sub>T</sub> mogul style conduit bodies are offered in numerous configurations to provide a complete coated conduit system. Mogul BG Covers are sold separately. Mogul style fitting bodies have long openings and may be used to make bends in conduit runs, for pull outlets for stiff conductors, to provide additional room for taps or splices, etc.. Electrical continuity of the conduit system is maintained across assembled joints.

- 40 mil gray PVC exterior coating
- 2 mil red urethane interior coating
- 8 trade sizes from 1" through 4"
- Sealing sleeves on all conduit openings
- Molded-in seal between bodies and covers
- Large cover openings provide ample room

#### Steel and Aluminum

- UL 514A, 514D (E231035)
- CSA C22.2 No. 18, CSA C22.2 No. 42

### Conduit Bodies – Mogul Technical Data

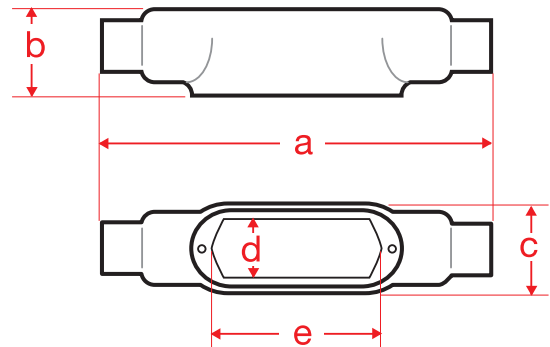

#### BC

| Pipe Size | FERROUS CATALOG # | Nominal Weight | A     | B    | C    | D    | E  | ALUMINUM CATALOG # |
|-----------|-------------------|----------------|-------|------|------|------|----|--------------------|
| 1"        | PRBC3             | 3.2            | 7.31  | 1.92 | 2.27 | 1.88 | 6  | PRBC3SA            |
| 1-1/4"    | PRBC4             | 4.2            | 8.50  | 2.35 | 2.27 | 1.88 | 6  | PRBC4SA            |
| 1-1/2"    | PRBC5             | 6.0            | 10.38 | 2.60 | 3.08 | 2.63 | 10 | PRBC5SA            |
| 2"        | PRBC6             | 7.0            | 12.25 | 3.17 | 3.08 | 2.63 | 10 | PRBC6SA            |
| 2-1/2"    | PRBC7             | 13.8           | 15.63 | 3.67 | 4.33 | 3.81 | 15 | PRBC7SA            |
| 3"        | PRBC8             | 17.5           | 15.63 | 4.42 | 4.33 | 3.81 | 15 | PRBC8SA            |
| 3-1/2"    | PRBC9             | 25.0           | 18.75 | 4.92 | 5.33 | 4.75 | 20 | PRBC9SA            |
| 4"        | PRBC10            | 28.0           | 18.75 | 5.42 | 5.33 | 4.75 | 20 | PRBC10SA           |

(cover sold separately)

#### APPROVAL STAMP

(See online product submittal guide at [www.plastibond.com](http://www.plastibond.com))

APPLICATION

FEATURES

COMPLIANCES



# CONDUIT BODIES AND COVERS FOR GENERAL SERVICE LOCATIONS

## Mogul Style Conduit Bodies - Technical Data

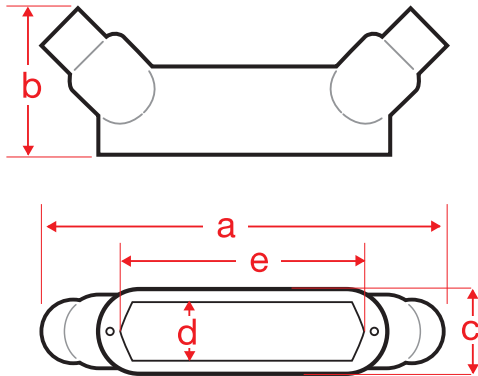

### BUB

| Pipe Size | FERROUS CATALOG # | Nominal Weight | A     | B    | C    | D    | E  | ALUMINUM CATALOG # |
|-----------|-------------------|----------------|-------|------|------|------|----|--------------------|
| 1"        | PRBUB3            | 3.2            | 10.19 | 2.73 | 2.27 | 1.88 | 6  | PRBUB3SA           |
| 1-1/4"    | PRBUB4            | 4.0            | 11.06 | 3.23 | 2.27 | 1.88 | 6  | PRBUB4SA           |
| 1-1/2"    | PRBUB5            | 5.9            | 15.00 | 3.54 | 3.08 | 2.63 | 10 | PRBUB5SA           |
| 2"        | PRBUB6            | 7.8            | 15.50 | 4.17 | 3.08 | 2.63 | 10 | PRBUB6SA           |
| 2-1/2"    | PRBUB7            | 12.5           | 19.75 | 4.85 | 4.33 | 3.81 | 15 | PRBUB7SA           |
| 3"        | PRBUB8            | 17.0           | 19.88 | 5.67 | 4.33 | 3.81 | 15 | PRBUB8SA           |
| 3-1/2"    | PRBUB9            | 25.0           | 25.38 | 6.42 | 5.33 | 4.75 | 20 | PRBUB9SA           |
| 4"        | PRBUB10           | 28.0           | 25.25 | 6.85 | 5.33 | 4.75 | 20 | PRBUB10SA          |

(cover sold separately)

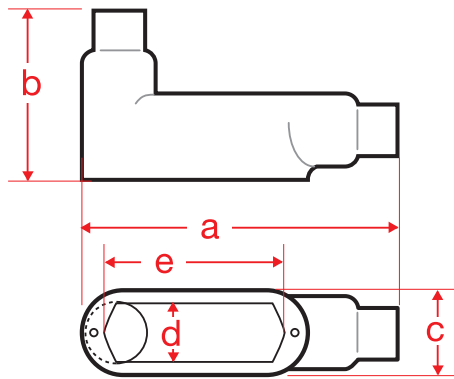

### BLB

| Pipe Size | FERROUS CATALOG # | Nominal Weight | A     | B    | C    | D    | E  | ALUMINUM CATALOG # |
|-----------|-------------------|----------------|-------|------|------|------|----|--------------------|
| 1"        | PRBLB3            | 3.2            | 9.63  | 2.88 | 2.27 | 1.88 | 6  | PRBLB3SA           |
| 1-1/4"    | PRBLB4            | 4.2            | 9.88  | 3.32 | 2.27 | 1.88 | 6  | PRBLB4SA           |
| 1-1/2"    | PRBLB5            | 6.0            | 14.23 | 3.67 | 3.08 | 2.63 | 10 | PRBLB5SA           |
| 2"        | PRBLB6            | 7.0            | 14.73 | 4.23 | 3.08 | 2.63 | 10 | PRBLB6SA           |
| 2-1/2"    | PRBLB7            | 13.8           | 18.95 | 5.13 | 4.33 | 3.81 | 15 | PRBLB7SA           |
| 3"        | PRBLB8            | 17.5           | 18.95 | 5.88 | 4.33 | 3.81 | 15 | PRBLB8SA           |
| 3-1/2"    | PRBLB9            | 25.0           | 24.17 | 6.54 | 5.33 | 4.75 | 20 | PRBLB9SA           |
| 4"        | PRBLB10           | 28.0           | 24.17 | 7.04 | 5.33 | 4.75 | 20 | PRBLB10SA          |

(cover sold separately)

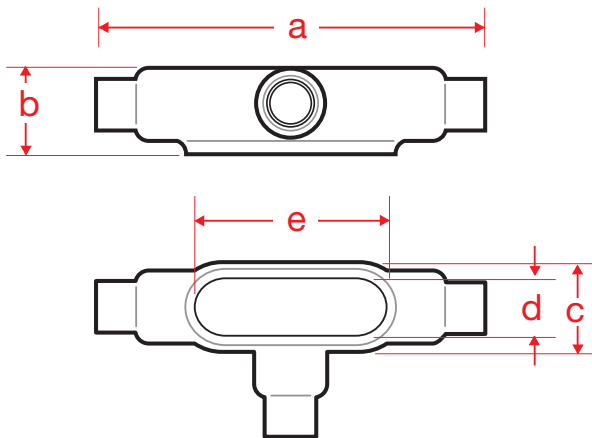

### BT

| Pipe Size | FERROUS CATALOG # | Nominal Weight | A     | B    | C    | D    | E  | ALUMINUM CATALOG # |
|-----------|-------------------|----------------|-------|------|------|------|----|--------------------|
| 1"        | PRBT3             | 3.2            | 11.56 | 1.92 | 4.20 | 1.88 | 6  | PRBT3SA            |
| 1-1/4"    | PRBT4             | 3.6            | 12.06 | 2.35 | 4.45 | 1.88 | 6  | PRBT4SA            |
| 1-1/2"    | PRBT5             | 7.5            | 16.75 | 2.60 | 5.60 | 2.63 | 10 | PRBT5SA            |
| 2"        | PRBT6             | 9.0            | 17.75 | 3.17 | 6.10 | 2.63 | 10 | PRBT6SA            |
| 2-1/2"    | PRBT7             | 15.0           | 22.38 | 3.67 | 7.63 | 3.81 | 15 | PRBT7SA            |
| 3"        | PRBT8             | 19.0           | 22.38 | 4.42 | 7.76 | 3.81 | 15 | PRBT8SA            |
| 3-1/2"    | PRBT9             | 29.0           | 27.75 | 4.92 | 8.92 | 4.75 | 20 | PRBT9SA            |
| 4"        | PRBT10            | 32.0           | 27.75 | 5.42 | 8.92 | 4.75 | 20 | PRBT10SA           |

(cover sold separately)

### BG COVERS (body sold separately)

| FERROUS CATALOG # | Description              | Nominal Weight | ALUMINUM CATALOG # |
|-------------------|--------------------------|----------------|--------------------|
| PRBG48            | 1 - 1 1/4 BG COVER MOGUL | 2.5            | PRBG48SA           |
| PRBG68            | 1 1/2 - 2 BG COVER MOGUL | 3.2            | PRBG68SA           |
| PRBG88            | 2 1/2 - 3 BG COVER MOGUL | 6.4            | PRBG88SA           |
| PRBG98            | 3 1/2 - 4 BG COVER MOGUL | 9.8            | PRBG98SA           |

### FS/FD Series Specifications

#### APPLICATION

PLASTI-BOND REDH<sub>2</sub>OT device boxes and covers are available in several configurations and may be used in coated conduit systems to accommodate wiring devices, to serve as pull boxes for conductors, or to allow for splices and taps in conductors. Covers are available separately. Electrical continuity of the conduit system is maintained across assembled joints.

#### FEATURES

- 40 mil gray PVC exterior coating
- 2 mil red urethane interior coating
- 3 trade sizes from 1/2" through 1"
- Available in Standard (PRFS) and Deep (PRFD) Styles
- Internal green grounding screw is standard
- Sealing sleeves on all conduit openings
- Flat molded PVC gasket mates with all standard covers

#### COMPLIANCES

##### Steel and Aluminum

- UL 514A, 514D (E231035)
- CSA C22.2 No. 18, CSA C22.2 No. 42



### REDH<sub>2</sub>OT PRODUCT FLASH

#### Five “Extra” Touches in the Battle Against Corrosion.

- 1.) The special PVC formulation for Plasti-Bond REDH<sub>2</sub>OT includes Ultraviolet Light (UV) inhibitors. Laboratory tests, exposure testing, and actual service all support the fact that we have never had a UV-related failure of PVC in more than 30 years!
- 2.) Plasti-Bond REDH<sub>2</sub>OT's PVC sealing sleeves are sized so they fit tightly over the coated conduit when assembled. This keeps corrosive elements away from the threaded joints.
- 3.) All Form 8 conduit cover screws are made from stainless steel with a plastic encapsulated head...yet another way of providing maximum corrosion protection by providing a seal around the screw opening.
- 4.) Plasti-Bond REDH<sub>2</sub>OT fittings provide gasket seals to keep corrosives from getting into the conduit system through joints and openings, protecting the interior of the system from corrosion.
- 5.) As experts in anti-corrosion coating technology, we have the ability to custom coat a variety of electrical and related products in addition to those listed in this Buyer's Guide. For additional details consult your Plasti-Bond sales rep or contact the factory direct at 903-843-5591.

#### APPROVAL STAMP

(See online product submittal guide at [www.plastibond.com](http://www.plastibond.com))

FS/FD Series Technical Data and Covers  
continued on following pages...

# PLASTI-BOND REDH<sub>2</sub>O<sup>T</sup> CAST DEVICE BOXES AND COVERS

## DEVICE BOX COVERS

### FS/FD Single Gang Cover Configurations

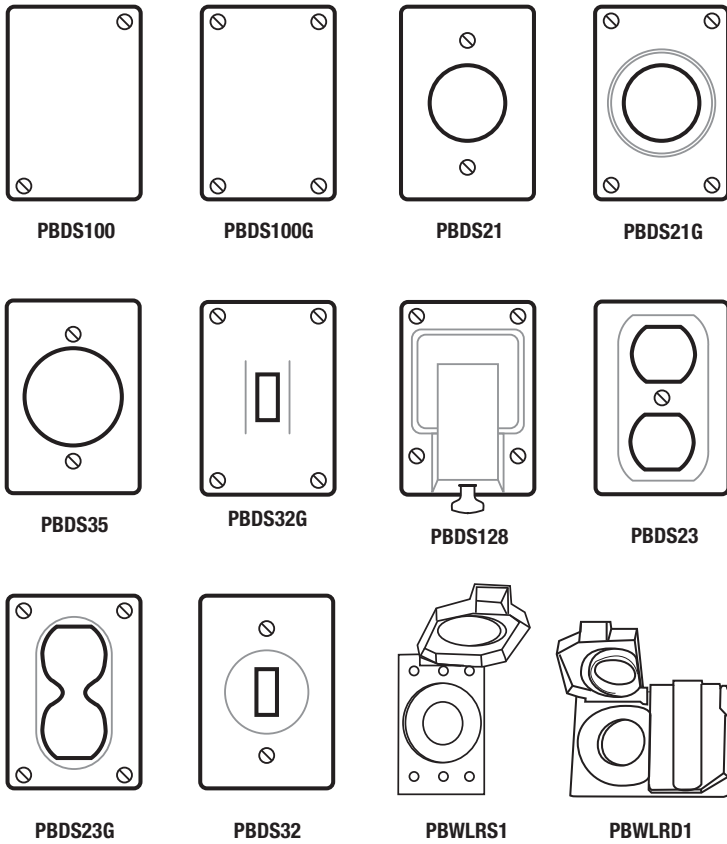

### FS/FD 2 Gang Cover Configurations

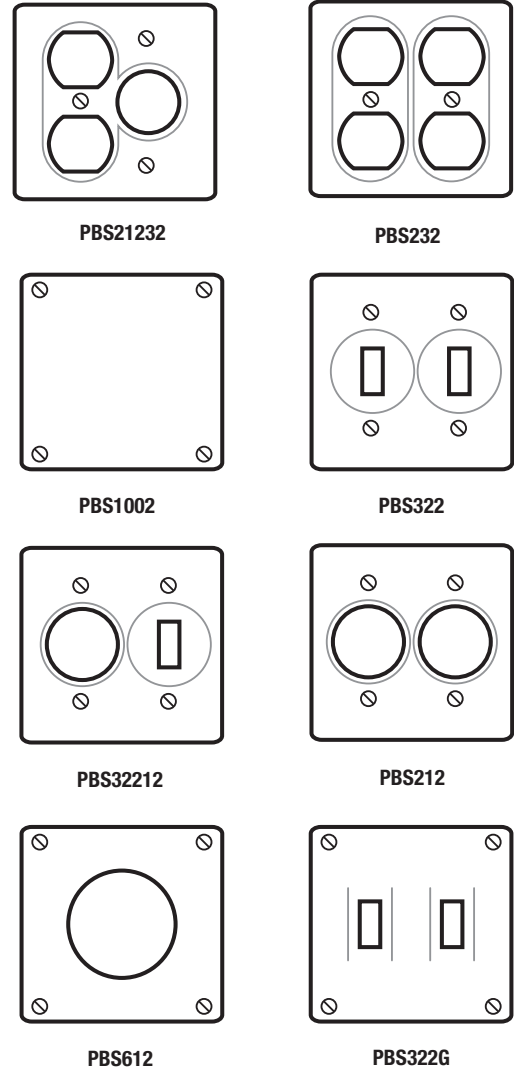

### FERROUS COVERS - ONE GANG

| CATALOG # | Description                                   | Nominal Weight |
|-----------|-----------------------------------------------|----------------|
| PBDS32    | GENERAL USE SNAP ON OR TOGGLE (S)             | 0.4            |
| PBDS23G   | DUPLEX CONVENIENCE RECEPTACLE (S,F)           | 0.4            |
| PBDS35    | PLUG RECEPTACLE 1 5/8" DIAMETER (S)           | 0.4            |
| PBDS21    | 3P 2W GROUNDING ROUND FLUSH RECEPTACLES (S)   | 0.3            |
| PBDS21G   | 3P 2W GROUNDING ROUND FLUSH RECEPTACLES (S,F) | 0.3            |
| PBDS23    | DUPLEX CONVENIENCE RECEPTACLE (S)             | 0.3            |
| PBDS32G   | SQUARE HANDLE SNAP OR TOGGLE (S, F)           | 0.4            |

### ALUMINUM COVERS - ONE GANG

| CATALOG # | Description                                 | Nominal Weight |
|-----------|---------------------------------------------|----------------|
| PBDS23SA  | DUPLEX CONVENIENCE RECEPTACLE (S)           | 0.1            |
| PBDS100   | BLANK COVER (S)                             | 0.1            |
| PBDS128   | SNAP SWITCH                                 | 0.5            |
| PBDS100G  | BLANK COVER CAST (S,F)                      | 0.3            |
| PBWLRD1   | SPRING DOOR DUPLEX COVER 1 3/8" (F)         | 0.4            |
| PBWLR1    | SPRING DOOR SINGLE COVER 1 3/8" (F)         | 0.3            |
| PBWLR2    | SPRING DOOR SINGLE COVER 1 1/2" (F)         | 0.3            |
| PRWLG-FS  | SPRING DOOR COVER FOR GFCI (S) – HORIZONTAL | 0.5            |
| PRWLG     | SPRING DOOR COVER FOR GFCI (F) – HORIZONTAL | 0.5            |

### FERROUS COVERS - TWO GANG

| CATALOG # | Description                           | Nominal Weight |
|-----------|---------------------------------------|----------------|
| PBS1002   | BLANK COVER SHEET STEEL (S)           | 1.0            |
| PBS1002G  | BLANK COVER IRON ALLOY (S,F)          | 1.0            |
| PBS21232  | ROUND RECEPTACLE + DUPLEX CONVENIENCE | 1.2            |
| PBS232    | DUPLEX CONVENIENCE (S)                | 1.2            |
| PBS322    | SNAP SWITCH (S)                       | 1.0            |
| PBS32212  | ROUND RECEPTACLE + SNAP SWITCH (S)    | 1.2            |
| PBS212    | TWO ROUND RECEPTACLES (S)             | 2.0            |
| PBS612    | 20 AMP, 250 VOLT RECEPTACLE (S)       | 1.2            |
| PBS322G   | SNAP SWITCHES IRON ALLOY (S,F)        | 1.2            |

### FERROUS COVERS - THREE GANG

| CATALOG # | Description       | Nominal Weight |
|-----------|-------------------|----------------|
| PBS323    | COVER SERVICE (F) | .3             |

NOTE: (S) SURFACE MOUNT, (F) FLUSH MOUNT



# PLASTI-BOND REDH<sub>2</sub>O<sup>T</sup> CAST DEVICE BOXES

## CAST DEVICE BOXES - SINGLE GANG

### FS/FD Series Dimensions - Single Gang

FS/FD Single Gang Dimensional Drawings

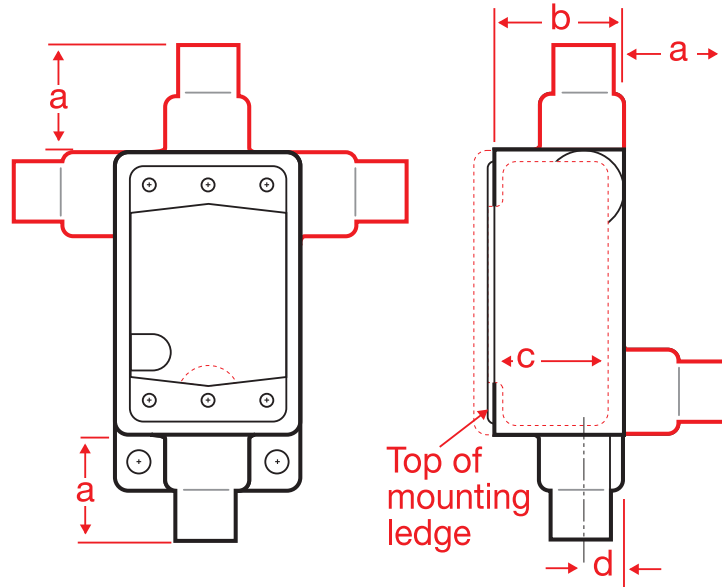

### FS/FD Series Configurations - Single Gang

All configurations offered in both 'FS' or 'FD' box depths. FS prefix: Shallow configuration, FD prefix: Deep configuration

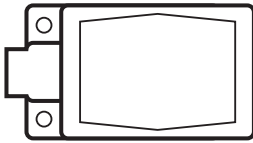

#### FS SERIES (SHALLOW BOX) - SINGLE GANG DEAD END

| Pipe Size | FERROUS CATALOG # | Nominal Weight | A    | B    | C    | D    | ALUMINUM CATALOG # |
|-----------|-------------------|----------------|------|------|------|------|--------------------|
| 1/2"      | PRFS1             | 3.2            | 1.38 | 1.92 | 1.69 | 0.67 | PRFS1SA*           |
| 3/4"      | PRFS2             | 3.3            | 1.63 | 1.92 | 1.69 | 0.79 | PRFS2SA*           |
| 1"        | PRFS3             | 3.5            | 2.00 | 1.92 | 1.69 | 0.92 | -                  |

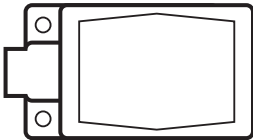

#### FD SERIES (DEEP BOX) - SINGLE GANG DEAD END

| Pipe Size | FERROUS CATALOG # | Nominal Weight | A    | B    | C    | D    | ALUMINUM CATALOG # |
|-----------|-------------------|----------------|------|------|------|------|--------------------|
| 1/2"      | PRFD1             | 2.7            | 1.38 | 1.92 | 2.69 | .67  | PRFD1SA*           |
| 3/4"      | PRFD2             | 2.8            | 1.63 | 1.92 | 2.69 | 0.79 | PRFD2SA*           |
| 1"        | PRFD3             | 3.1            | 2.00 | 1.92 | 2.69 | 0.92 | PRFD3SA*           |

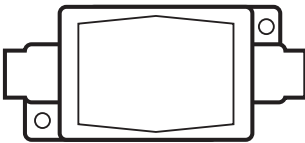

#### FSC SERIES (SHALLOW BOX) - SINGLE GANG THROUGH FEED

| Pipe Size | FERROUS CATALOG # | Nominal Weight | A    | B    | C    | D    | ALUMINUM CATALOG # |
|-----------|-------------------|----------------|------|------|------|------|--------------------|
| 1/2"      | PRFSC1            | 2.2            | 1.38 | 1.92 | 1.69 | 0.67 | PRFSC1SA*          |
| 3/4"      | PRFSC2            | 2.4            | 1.63 | 1.92 | 1.69 | 0.79 | PRFSC2SA*          |
| 1"        | PRFSC3            | 2.7            | 2.00 | 1.92 | 1.69 | 0.92 | -                  |

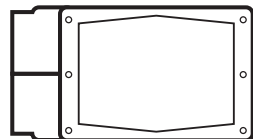

#### FSS SERIES

| Pipe Size | FERROUS CATALOG # | Nominal Weight | A    | B    | C    | D    | ALUMINUM CATALOG # |
|-----------|-------------------|----------------|------|------|------|------|--------------------|
| 1/2"      | PRFSS1            | 3.2            | 1.38 | 1.92 | 1.69 | 0.67 | PRFSS1SA*          |
| 3/4"      | PRFSS2            | 3.3            | 1.63 | 1.92 | 1.69 | 0.79 | PRFSS2SA*          |
| 1"        | PRFSS3            | 3.5            | 2.00 | 1.92 | 1.69 | 0.92 | -                  |

\*Available in copper free aluminum

# PLASTI-BOND REDH<sub>2</sub>O<sup>T</sup> CAST DEVICE BOXES

## CAST DEVICE BOXES - SINGLE GANG

### FS/FD Series Configurations - Single Gang

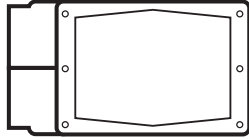

#### FDD SERIES

| Pipe Size | FERROUS CATALOG # | Nominal Weight | A    | B    | C    | D    | ALUMINUM CATALOG # |
|-----------|-------------------|----------------|------|------|------|------|--------------------|
| 1/2"      | PRFDD1            | 2.7            | 1.38 | 1.92 | 2.69 | .67  | PRFD1SA*           |
| 3/4"      | PRFDD2            | 2.8            | 1.63 | 1.92 | 2.69 | 0.79 | PRFD2SA*           |
| 1"        | PRFDD3            | 3.1            | 2.00 | 1.92 | 2.69 | 0.92 | PRFD3SA*           |

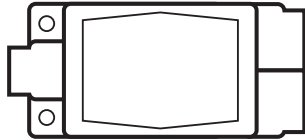

#### FSCC SERIES

| Pipe Size | CATALOG # | Nominal Weight | A    | B    | C    | D    |
|-----------|-----------|----------------|------|------|------|------|
| 1/2"      | PRFSCC1   | 2.0            | 1.38 | 1.92 | 1.69 | 0.67 |
| 3/4"      | PRFSCC2   | 2.2            | 1.63 | 1.92 | 1.69 | 0.79 |

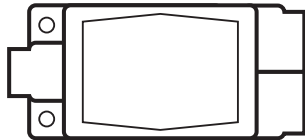

#### FDCC SERIES

| Pipe Size | FERROUS CATALOG # | Nominal Weight | A    | B    | C    | D    | ALUMINUM CATALOG # |
|-----------|-------------------|----------------|------|------|------|------|--------------------|
| 1/2"      | PRFDCC1           | 2.7            | 1.38 | 1.92 | 2.69 | 0.67 | PRFDCC1SA*         |
| 3/4"      | PRFDCC2           | 2.8            | 1.63 | 1.92 | 2.69 | 0.79 | PRFDCC2SA*         |

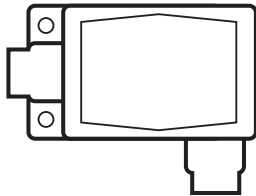

#### FDL SERIES

| Pipe Size | CATALOG # | Nominal Weight | A    | B    | C    | D    |
|-----------|-----------|----------------|------|------|------|------|
| 1/2"      | PRFDL1    | 3.1            | 1.38 | 1.92 | 2.69 | 0.67 |
| 3/4"      | PRFDL2    | 3.3            | 1.63 | 1.92 | 2.69 | 0.79 |

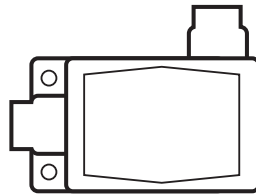

#### FDR SERIES

| Pipe Size | CATALOG # | Nominal Weight | A    | B    | C    | D    |
|-----------|-----------|----------------|------|------|------|------|
| 1/2"      | PRFDR1    | 3.2            | 1.38 | 1.92 | 2.69 | 0.67 |
| 3/4"      | PRFDR2    | 3.3            | 1.63 | 1.92 | 2.69 | 0.79 |

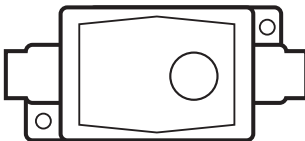

#### FSCA SERIES

| Pipe Size | CATALOG # | Nominal Weight | A    | B    | C    | D    |
|-----------|-----------|----------------|------|------|------|------|
| 1/2"      | PRFSCA1   | 2.5            | 1.38 | 1.92 | 1.69 | 0.67 |
| 3/4"      | PRFSCA2   | 3.5            | 1.63 | 1.92 | 1.69 | 0.79 |

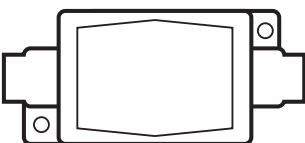

#### FDC SERIES (DEEP BOX) – SINGLE GANG THROUGH FEED

| Pipe Size | FERROUS CATALOG # | Nominal Weight | A    | B    | C    | D    | ALUMINUM CATALOG # |
|-----------|-------------------|----------------|------|------|------|------|--------------------|
| 1/2"      | PRFDC1            | 2.7            | 1.38 | 1.92 | 2.69 | 0.67 | PRFDC1SA*          |
| 3/4"      | PRFDC2            | 2.8            | 1.63 | 1.92 | 2.69 | 0.79 | PRFDC2SA*          |
| 1"        | PRFDC3            | 3.1            | 2.00 | 1.92 | 2.69 | 0.92 | PRFDC3SA*          |

# PLASTI-BOND REDH<sub>2</sub>O<sup>T</sup> CAST DEVICE BOXES

## CAST DEVICE BOXES - SINGLE GANG CONTINUED

### FS/FD Series Configurations - Single Gang Continued

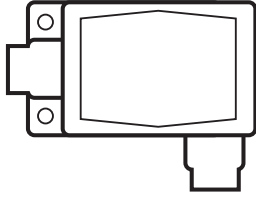

#### FSL SERIES

| Pipe Size | CATALOG # | Nominal Weight | A    | B    | C    | D    |
|-----------|-----------|----------------|------|------|------|------|
| 1/2"      | PRFSL1    | 2.5            | 1.38 | 1.92 | 1.69 | 0.67 |
| 3/4"      | PRFSL2    | 2.7            | 1.63 | 1.92 | 1.69 | 0.79 |

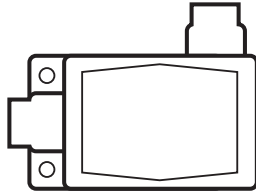

#### FSR SERIES

| Pipe Size | CATALOG # | Nominal Weight | A    | B    | C    | D    |
|-----------|-----------|----------------|------|------|------|------|
| 1/2"      | PRFSR1    | 2.0            | 1.38 | 1.92 | 1.69 | 0.67 |
| 3/4"      | PRFSR2    | 2.2            | 1.63 | 1.92 | 1.69 | 0.79 |

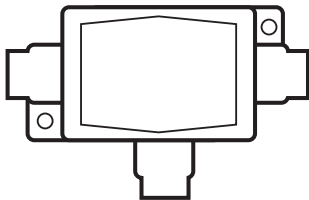

#### FDCT SERIES

| Pipe Size | CATALOG # | Nominal Weight | A    | B    | C    | D    |
|-----------|-----------|----------------|------|------|------|------|
| 1/2"      | PRFDCT1   | 3.1            | 1.38 | 1.92 | 2.69 | 0.67 |
| 3/4"      | PRFDCT2   | 3.4            | 1.63 | 1.92 | 2.69 | 0.79 |
| 1"        | PRFDCT3   | 3.9            | 2.00 | 1.92 | 2.69 | 0.92 |

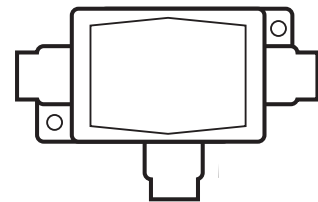

#### FSCT SERIES

| Pipe Size | CATALOG # | Nominal Weight | A    | B    | C    | D    |
|-----------|-----------|----------------|------|------|------|------|
| 1/2"      | PRFSCT1   | 2.2            | 1.38 | 1.92 | 1.69 | 0.67 |
| 3/4"      | PRFSCT2   | 2.5            | 1.63 | 1.92 | 1.69 | 0.79 |
| 1"        | PRFSCT3   | 2.8            | 2.00 | 1.92 | 1.69 | 0.79 |

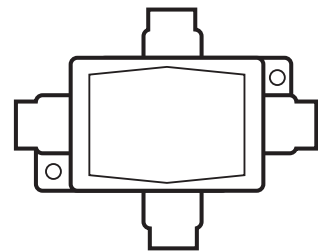

#### FSX SERIES

| Pipe Size | CATALOG # | Nominal Weight | A    | B    | C    | D    |
|-----------|-----------|----------------|------|------|------|------|
| 1/2"      | PRFSX1    | 2.5            | 1.38 | 1.92 | 1.69 | 0.67 |
| 3/4"      | PRFSX2    | 2.7            | 1.63 | 1.92 | 1.69 | 0.79 |

#### FDX SERIES

| Pipe Size | CATALOG # | Nominal Weight | A    | B    | C    | D    |
|-----------|-----------|----------------|------|------|------|------|
| 1/2"      | PRFDX1    | 2.5            | 1.38 | 1.92 | 2.69 | 0.67 |
| 3/4"      | PRFDX2    | 2.7            | 1.63 | 1.92 | 2.69 | 0.79 |
| 1"        | PRFDX3    | 2.5            | 1.38 | 1.92 | 2.69 | 0.67 |

APPROVAL STAMP

# PLASTI-BOND REDH<sub>2</sub>O<sup>T</sup> CAST DEVICE BOXES

## CAST DEVICE BOXES - TWO GANG

FS/FD 2 Gang Dimensional Drawings

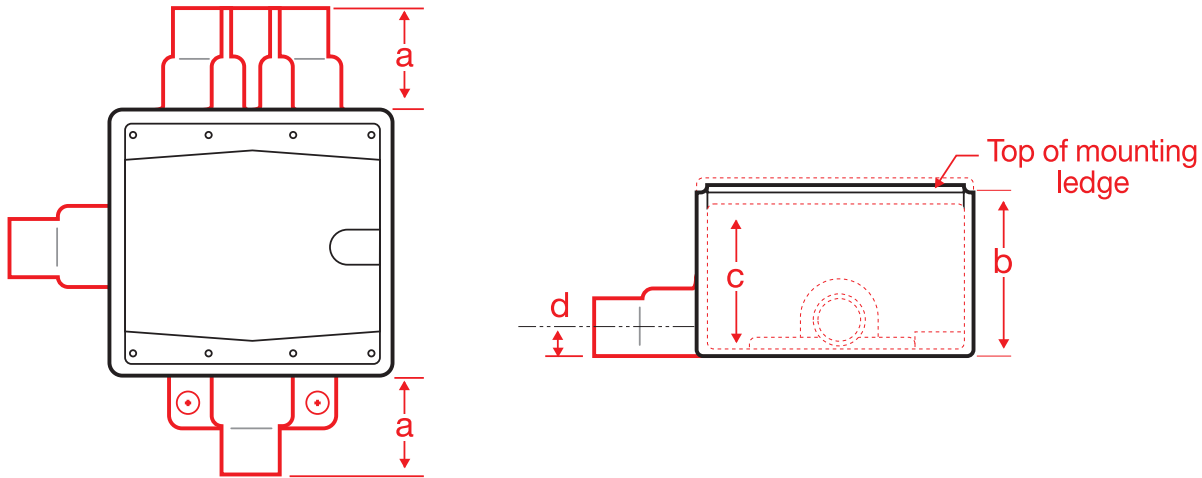

### FS/FD Series Configurations - Two Gang

All configurations offered in both 'FS' or 'FD' box depths. FS prefix: Shallow configuration, FD prefix: Deep configuration

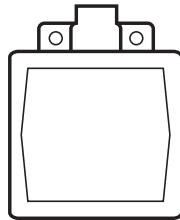

FS/FD  
(Two Gang)

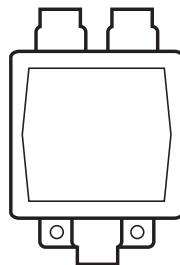
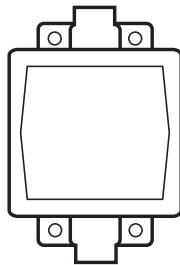

#### FS SERIES (SHALLOW BOX) – TWO GANG DEAD END

| Pipe Size | FERROUS CATALOG # | Nominal Weight | A    | B    | C    | D    | ALUMINUM CATALOG # |
|-----------|-------------------|----------------|------|------|------|------|--------------------|
| 1/2"      | PRFS12            | 3.3            | 1.38 | 1.92 | 1.69 | 0.67 | PRFS12SA*          |
| 3/4"      | PRFS22            | 3.4            | 1.63 | 1.92 | 1.69 | 0.79 | PRFS22SA*          |
| 1"        | PRFS32            | 3.6            | 2.00 | 1.92 | 1.69 | 0.92 | –                  |

#### FD SERIES (DEEP BOX) – TWO GANG

| Pipe Size | FERROUS CATALOG # | Nominal Weight | A     | B    | C    | D    | ALUMINUM CATALOG # |
|-----------|-------------------|----------------|-------|------|------|------|--------------------|
| 1/2"      | PRFD12            | 3.3            | 1.38  | 1.92 | 1.69 | 0.67 | –                  |
| 3/4"      | PRFD22            | 3.3            | 1.163 | 1.92 | 2.69 | 0.79 | –                  |
| 1"        | PRFD32            | 3.6            | 2.00  | 1.92 | 1.69 | 0.92 | –                  |

#### FSC SERIES (SHALLOW BOX) – TWO GANG THROUGH FEED

| Pipe Size | FERROUS CATALOG # | Nominal Weight | A    | B    | C    | D    | ALUMINUM CATALOG # |
|-----------|-------------------|----------------|------|------|------|------|--------------------|
| 1/2"      | PRFSC12           | 3.3            | 1.38 | 1.92 | 1.69 | 0.67 | –                  |
| 3/4"      | PRFSC222          | 3.6            | 1.63 | 1.92 | 1.69 | 0.79 | –                  |
| 1"        | PRFSC32           | 4.0            | 2.00 | 1.92 | 1.69 | 0.92 | –                  |

#### FSD SERIES

| Pipe Size | CATALOG # | Nominal Weight | A    | B    | C    | D   | Bottom Hubs |
|-----------|-----------|----------------|------|------|------|-----|-------------|
| 3/4"      | PRFSD212  | 2.5            | 1.63 | 1.92 | 1.69 | .79 | 1/2"        |

APPROVAL STAMP



# PLASTI-BOND REDH<sub>2</sub>OT GUA SERIES OUTLET BOXES

## CONDUIT OUTLET BOXES FOR HAZARDOUS LOCATIONS



PRGUAT26

### GUA Series Specifications

PLASTI-BOND REDH<sub>2</sub>OT GUA series conduit outlet boxes are installed in hazardous location conduit systems to serve as pull and splice boxes, to change the direction of a conduit run, to connect runs of conduit, or to provide access to conductors. They are provided with covers as standard. Inquire about special covers to allow use to mount lighting fixtures or as sealing fittings. Electrical continuity of the conduit system is maintained across assembled joints.

- 40 mil gray PVC exterior coating
- 2 mil red urethane interior coating
- Trade sizes from 1/2" through 2" in various styles and configurations
- Sealing sleeves on all conduit openings
- Neoprene O-ring is standard
- Molded-in PVC seal preserves venting characteristics of fitting but seals out corrosives
- Standard material is a cast iron alloy body with a copper-free aluminum cover. Consult Factory for availability of cast iron covers
- Internal green grounding screw is standard

#### Steel and Aluminum

- UL 514A, 514D (E231035)
- CSA G22.2 No. 18, CSA C22.2 No. 42
- NEC/CEC:
  - Class I, Division 1 & 2, Groups C, D
  - Class II, Division 1, Groups E, F, G
  - Class II, Division 2, Groups F, G
  - Class III
- ANSI Standard C-33.27
- NEMA/EEMAC 3,4

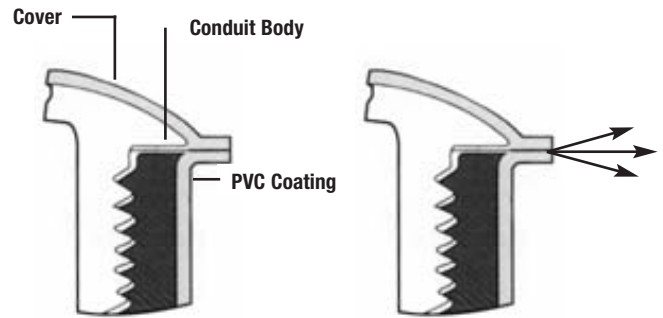

An integral PVC gasket on GUA type fittings preserves the venting characteristics of the uncoated fitting but prevents corrosive liquids from entering from the outside.

### GUA Series Dimensions

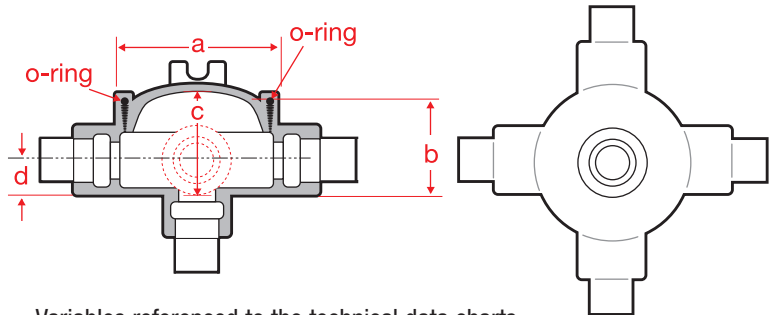

Variables referenced to the technical data charts

### GUA Series Configurations

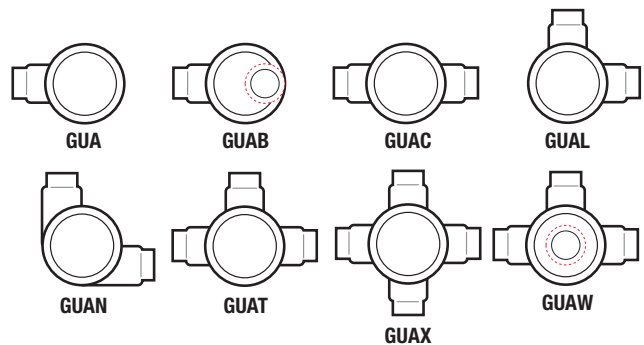

APPLICATION

FEATURES

COMPLIANCES

#### APPROVAL STAMP

(See online product submittal guide at [www.plastibond.com](http://www.plastibond.com))

# CONDUIT OUTLET BOXES FOR HAZARDOUS LOCATIONS

## GUA Series Technical Data

### **GUAB**

| Pipe Size | FERROUS CATALOG # | Cover Opening | Nominal Weight | ALUMINUM CATALOG # | Product Dimensions |      |      |      |
|-----------|-------------------|---------------|----------------|--------------------|--------------------|------|------|------|
|           |                   |               |                |                    | A                  | B    | C    | D    |
| 1/2"      | PRGUAB14          | 2"            | 2.0            | —                  | 2.58               | 2.29 | 2.38 | 0.67 |
| 1/2"      | PRGUAB16          | 3"            | 3.2            | PRGUAB16SA         | 3.58               | 2.04 | 1.88 | 0.67 |
| 3/4"      | PRGUAB24          | 2"            | 2.2            | —                  | 2.58               | 2.54 | 2.44 | 0.79 |
| 3/4"      | PRGUAB26          | 3"            | 3.3            | PRGUAB26SA         | 3.58               | 2.04 | 1.88 | 0.79 |
| 1"        | PRGUAB36          | 3"            | 3.8            | PRGUAB36SA         | 3.58               | 2.35 | 2.19 | 0.92 |
| 1-1/4"    | PRGUAB47          | 3-5/8"        | 5.0            | PRGUAB47SA         | 4.33               | 2.73 | 2.75 | 1.13 |
| 1-1/2"    | PRGUAB59          | 5"            | 8.1            | PRGUAB59SA         | 5.83               | 3.85 | 3.75 | 1.32 |
| 2"        | PRGUAB69          | 5"            | 9.1            | PRGUAB69SA         | 5.83               | 4.10 | 4.00 | 1.60 |

### **GUAC**

| Pipe Size | FERROUS CATALOG # | Cover Opening | Nominal Weight | ALUMINUM CATALOG # | Product Dimensions |      |      |      |
|-----------|-------------------|---------------|----------------|--------------------|--------------------|------|------|------|
|           |                   |               |                |                    | A                  | B    | C    | D    |
| 1/2"      | PRGUAC14          | 2"            | 3.5            | —                  | 2.58               | 2.29 | 2.19 | 0.67 |
| 1/2"      | PRGUAC16          | 3"            | 2.0            | PRGUAC16SA         | 3.58               | 2.04 | 1.88 | 0.67 |
| 3/4"      | PRGUAC24          | 2"            | 3.5            | PRGUAC24SA         | 2.58               | 2.04 | 2.00 | 0.79 |
| 3/4"      | PRGUAC26          | 3"            | 2.0            | PRGUAC26SA         | 3.58               | 2.04 | 1.88 | 0.79 |
| 1"        | PRGUAC36          | 3"            | 3.9            | PRGUAC36SA         | 3.58               | 2.35 | 2.19 | 0.92 |
| 1-1/4"    | PRGUAC47          | 3-5/8"        | 5.2            | PRGUAC47SA         | 4.33               | 2.73 | 2.75 | 1.13 |
| 1-1/4"    | PRGUAC49          | 5"            | 9.5            | —                  | 5.83               | 3.85 | 3.75 | 1.20 |
| 1-1/2"    | PRGUAC59          | 5"            | 11.0           | PRGUAC59SA         | 5.83               | 3.85 | 3.75 | 1.32 |
| 2"        | PRGUAC69          | 5"            | 11.0           | PRGUAC69SA         | 5.83               | 4.10 | 4.00 | 1.60 |

### **GUAL**

| Pipe Size | FERROUS CATALOG # | Cover Opening | Nominal Weight | ALUMINUM CATALOG # | Product Dimensions |      |      |      |
|-----------|-------------------|---------------|----------------|--------------------|--------------------|------|------|------|
|           |                   |               |                |                    | A                  | B    | C    | D    |
| 1/2"      | PRGUAL14          | 2"            | 2.0            | —                  | 2.58               | 2.29 | 2.19 | 0.67 |
| 1/2"      | PRGUAL16          | 3"            | 2.1            | PRGUAL16SA         | 3.58               | 2.04 | 1.88 | 0.67 |
| 3/4"      | PRGUAL24          | 2"            | 3.2            | PRGUAL24SA         | 2.58               | 2.54 | 2.44 | 0.79 |
| 3/4"      | PRGUAL26          | 3"            | 2.5            | PRGUAL26SA         | 3.58               | 2.04 | 1.88 | 0.79 |
| 1"        | PRGUAL36          | 3"            | 3.7            | PRGUAL36SA         | 3.58               | 2.35 | 2.19 | 0.92 |
| 1-1/4"    | PRGUAL47          | 3-5/8"        | 5.2            | PRGUAL47SA         | 4.33               | 2.73 | 2.75 | 1.13 |
| 1-1/4"    | PRGUAL49          | 5"            | 8.5            | —                  | 5.83               | 3.85 | 3.75 | 1.20 |
| 1-1/2"    | PRGUAL59          | 5"            | 11.2           | PRGUAL59SA         | 5.83               | 3.85 | 3.75 | 1.32 |
| 2"        | PRGUAL69          | 5"            | 12.5           | PRGUAL69SA         | 5.83               | 4.10 | 4.00 | 1.60 |

### **GUAN**

| Pipe Size | FERROUS CATALOG # | Cover Opening | Nominal Weight | ALUMINUM CATALOG # | Product Dimensions |      |      |      |
|-----------|-------------------|---------------|----------------|--------------------|--------------------|------|------|------|
|           |                   |               |                |                    | A                  | B    | C    | D    |
| 1/2"      | PRGUAN14          | 2"            | 2.0            | —                  | 2.58               | 2.17 | 2.06 | 0.67 |
| 1/2"      | PRGUAN16          | 3"            | 3.8            | —                  | 3.58               | 2.04 | 1.88 | 0.79 |
| 3/4"      | PRGUAN24          | 2"            | 2.5            | —                  | 2.58               | 2.35 | 2.25 | 0.79 |
| 3/4"      | PRGUAN26          | 3"            | 3.5            | —                  | 3.58               | 2.04 | 1.88 | 0.79 |
| 1"        | PRGUAN36          | 3"            | 3.0            | —                  | 3.58               | 2.35 | 2.38 | 0.92 |
| 1-1/4"    | PRGUAN47          | 3-5/8"        | 5.2            | —                  | 4.33               | 2.73 | 2.75 | 1.13 |
| 1-1/2"    | PRGUAN59          | 5"            | 9.5            | —                  | 5.83               | 4.10 | 4.00 | 1.32 |
| 2"        | PRGUAN69          | 5"            | 12.0           | —                  | 5.83               | 4.10 | 4.00 | 1.60 |

### **GUAT**

| Pipe Size | FERROUS CATALOG # | Cover Opening | Nominal Weight | ALUMINUM CATALOG # | Product Dimensions |      |      |      |
|-----------|-------------------|---------------|----------------|--------------------|--------------------|------|------|------|
|           |                   |               |                |                    | A                  | B    | C    | D    |
| 1/2"      | PRGUAT14          | 2"            | 2.0            | —                  | 2.58               | 2.29 | 2.19 | 0.67 |
| 1/2"      | PRGUAT16          | 3"            | 2.8            | PRGUAT16SA         | 3.58               | 2.04 | 1.88 | 0.67 |
| 3/4"      | PRGUAT24          | 2"            | 2.2            | —                  | 2.58               | 2.04 | 2.00 | 0.79 |
| 3/4"      | PRGUAT26          | 3"            | 3.5            | PRGUAT26SA         | 3.58               | 2.04 | 1.88 | 0.79 |
| 1"        | PRGUAT36          | 3"            | 3.2            | PRGUAT36SA         | 3.58               | 2.35 | 2.19 | 0.92 |
| 1-1/4"    | PRGUAT47          | 3-5/8"        | 5.7            | PRGUAT47SA         | 4.33               | 2.73 | 2.75 | 1.13 |
| 1-1/2"    | PRGUAT59          | 5"            | 9.1            | PRGUAT59SA         | 5.83               | 3.85 | 3.75 | 1.32 |
| 2"        | PRGUAT69          | 5"            | 10.0           | PRGUAT69SA         | 5.83               | 4.10 | 4.00 | 1.60 |

### **GUAW**

| Pipe Size | FERROUS CATALOG # | Cover Opening | Nominal Weight | ALUMINUM CATALOG # | Product Dimensions |      |      |      |
|-----------|-------------------|---------------|----------------|--------------------|--------------------|------|------|------|
|           |                   |               |                |                    | A                  | B    | C    | D    |
| 1/2"      | PRGUAW14          | 2"            | 2.0            | —                  | 2.58               | 1.85 | 1.75 | 0.67 |
| 1/2"      | PRGUAW16          | 3"            | 2.0            | —                  | 3.58               | 2.04 | 1.88 | 0.67 |
| 3/4"      | PRGUAW24          | 2"            | 3.0            | —                  | 2.58               | 2.04 | 2.00 | 0.79 |
| 3/4"      | PRGUAW26          | 3"            | 3.0            | —                  | 3.58               | 2.04 | 1.88 | 0.79 |

### **GUAX**

| Pipe Size | FERROUS CATALOG # | Cover Opening | Nominal Weight | ALUMINUM CATALOG # | Product Dimensions |      |      |      |
|-----------|-------------------|---------------|----------------|--------------------|--------------------|------|------|------|
|           |                   |               |                |                    | A                  | B    | C    | D    |
| 1/2"      | PRGUAX14          | 2"            | 2.0            | —                  | 2.58               | 1.85 | 1.75 | 0.67 |
| 1/2"      | PRGUAX16          | 3"            | 3.8            | PRGUAX16SA         | 3.58               | 2.04 | 1.88 | 0.67 |
| 3/4"      | PRGUAX24          | 2"            | 2.5            | PRGUAX24SA         | 2.58               | 2.04 | 2.00 | 0.79 |
| 3/4"      | PRGUAX26          | 3"            | 2.8            | PRGUAX26SA         | 3.58               | 2.04 | 1.88 | 0.79 |
| 1"        | PRGUAX36          | 3"            | 4.2            | PRGUAX36SA         | 3.58               | 2.35 | 2.19 | 0.92 |
| 1-1/4"    | PRGUAX47          | 3-5/8"        | 4.8            | PRGUAX47SA         | 4.33               | 2.73 | 2.75 | 1.13 |
| 1-1/2"    | PRGUAX59          | 5"            | 11.7           | PRGUAX59SA         | 5.83               | 3.85 | 3.75 | 1.32 |
| 2"        | PRGUAX69          | 5"            | 12.5           | PRGUAX69SA         | 5.83               | 4.10 | 4.00 | 1.60 |

### **GUAD**

| Pipe Size | FERROUS CATALOG # | Cover Opening | Nominal Weight | ALUMINUM CATALOG # | Product Dimensions |      |      |      |
|-----------|-------------------|---------------|----------------|--------------------|--------------------|------|------|------|
|           |                   |               |                |                    | A                  | B    | C    | D    |
| 1/2"      | PRGUAD14          | 2"            | 2.0            | —                  | 2.58               | 1.85 | 1.75 | 0.67 |
| 1/2"      | PRGUAD16          | 3"            | 3.2            | —                  | 3.58               | 2.04 | 1.88 | 0.67 |
| 3/4"      | PRGUAD24          | 2"            | 3.5            | —                  | 2.58               | 2.04 | 2.00 | 0.79 |
| 3/4"      | PRGUAD26          | 3"            | 3.8            | —                  | 3.58               | 2.04 | 1.88 | 0.79 |
| 1"        | PRGUAD36          | 3"            | 3.8            | —                  | 3.58               | 2.35 | 2.19 | 0.92 |
| 1-1/4"    | PRGUAD49          | 5"            | 10.9           | —                  | 5.83               | 3.85 | 3.75 | 1.13 |

# PLASTI-BOND REDH<sub>2</sub>OT OE SERIES OUTLET BOXES

## CONDUIT OUTLET BOXES FOR HAZARDOUS LOCATIONS



PROELB1

### OE Series Specifications

#### OE Series Dimensions

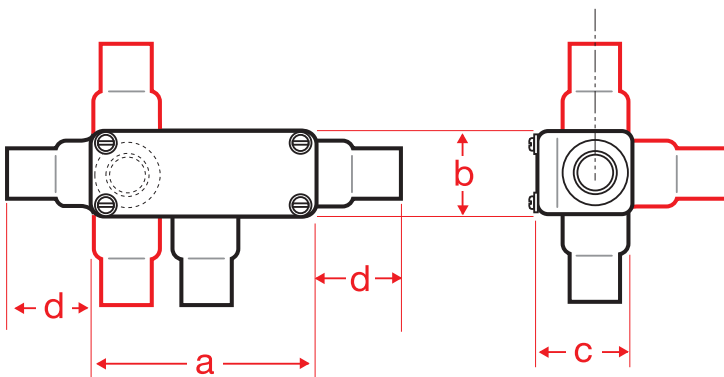

#### OE Series Technical Data

##### OELB OUTLET BOXES

| Pipe Size | FERROUS CATALOG # | Nominal Weight | A    | B    | C    | D    |
|-----------|-------------------|----------------|------|------|------|------|
| 1/2"      | PROELB1           | 2.2            | 4.14 | 1.64 | 1.89 | 1.19 |
| 3/4"      | PROELB2           | 3.0            | 4.39 | 1.96 | 2.14 | 1.44 |

##### OET OUTLET BOXES

| Pipe Size | FERROUS CATALOG # | Nominal Weight | A    | B    | C    | D    |
|-----------|-------------------|----------------|------|------|------|------|
| 1/2"      | PROET1            | 2.2            | 4.14 | 1.64 | 2.31 | 1.19 |
| 3/4"      | PROET2            | 3.0            | 4.39 | 1.96 | 2.81 | 1.44 |

#### APPLICATION

PLASTI-BOND REDH<sub>2</sub>OT OE Series Conduit Outlet Boxes are installed in hazardous location conduit systems to serve as pulling and splicing fittings, to connect runs of conduit, to change the direction of a conduit run, or to provide access to conductors. They are provided with covers. Electrical continuity of the conduit system is maintained across assembled joints.

#### FEATURES

- 40 mil gray PVC exterior coating
- 2 mil red urethane interior coating
- Available in 1/2" or 3/4" trade sizes
- Molded in PVC cover to body gasket seals corrosives out
- Sealing sleeves on all conduit openings
- Compact design saves space
- Encapsulated stainless steel cover screws

#### COMPLIANCES

- NEC/CEC:  
Class I, Division 1 & 2, Groups C, D  
Class II, Division 1, Groups E, F, G  
Class II, Division 2, Groups F, G  
Class III

#### APPROVAL STAMP

(See online product submittal guide at [www.plastibond.com](http://www.plastibond.com))

# PLASTI-BOND REDH<sub>2</sub>OT SEALING FITTINGS

## SEALING FITTINGS



These PLASTI-BOND REDH<sub>2</sub>OT sealing fittings should be used with a suitable system of sealing compound, such as Chico A, Chico X or Chico A-P from Crouse-Hinds. Follow the installation instructions included with the sealing compound.

### APPROVAL STAMP

(See online product submittal guide at [www.plastibond.com](http://www.plastibond.com))



### Sealing Fittings Specifications

PLASTI-BOND REDH<sub>2</sub>OT Sealing Fittings are used in conduit runs to stop gasses, vapors or flames from migrating from one part of the conduit system to another. This limits the spread of any potential explosion, enhancing safety. The PVC and urethane coatings of the fittings protects them from corrosive atmospheres so they can continue to function in hazardous locations. These fittings are available in several different configurations and with optional breathers and drains to accommodate installation in a variety of locations and positions. The EYD, EYDX and EZD styles of fittings are for installation in vertical conduit runs. The EYS and EYSX style fittings are for installation in either vertical or horizontal runs. The EZS style fitting may be used in any angle of conduit run.

#### APPLICATION

#### FEATURES

- 40 mil gray PVC exterior coating
- 2 mil red urethane interior coating
- 10 trade sizes from 1/2" through 4"
- Sealing sleeves on all conduit openings
- EYDX and EYSX seals have 40% wire fill capacity
- EYD and EZD fittings include a drain for condensate
- EZD fittings may be used at any conduit angle and include drain

#### COMPLIANCES

- NEC/CEC:
  - EYS 1-3, 11-31, 16-36, 116-316
  - EYS 29, 4-014, 46-0146, EZS 1-8, 16-86, EYD 1-10, 16-106, EZD 10-60, 111-611
  - Class I, Division 1 & 2, Groups A, B, C, D
  - Class I, Division 1 & 2, Groups C, D
  - Class II, Division 1, Groups E, F, G
  - Class II, Division 1, Groups F, G
  - Class II, Division 2, Groups F, G
  - Class III
  - Class II, Division 2, Groups F, G
  - Class III
- EYS 41-101, 416-1016, EYSX 11-81, EYD 11-101, 116-1016, EYDX 11-81
- EYSX 9-10
- Class I, Division 1 & 2, Groups B, C, D
- Class I, Division 1 & 2, Groups C, D
- Class II, Division 1, Groups E, F, G
- Class II, Division 1, Groups E, F, G
- Class II, Division 2, Groups F, G
- Class II, Division 2, Groups F, G
- Class III
- Class III



**Sealing Fittings Technical Data**

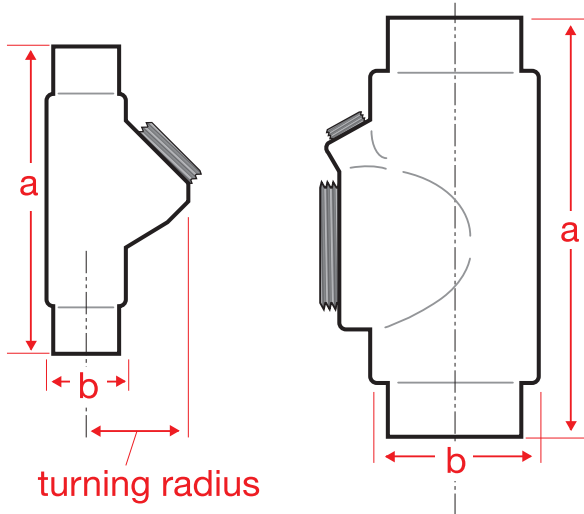

These PLASTI-BOND REDH<sub>2</sub>OT sealing fittings should be used with a suitable system of sealing compound, such as Chico A, Chico X or Chico A-P from Crouse-Hinds. Follow the installation instructions included with the sealing compound.

**EYSX - EXPANDED FILL FEMALE HUBS FOR SEALING IN VERTICAL OR HORIZONTAL POSITIONS**

| Pipe Size | FERROUS Catalog # | Nominal Weight | A     | B    | Turning Radius | Aluminum Catalog # |
|-----------|-------------------|----------------|-------|------|----------------|--------------------|
| 1/2"      | PREYSX11          | 1.5            | 4.69  | 1.58 | 1.25           | PREYSX1SA          |
| 3/4"      | PREYSX21          | 2.1            | 5.81  | 1.83 | 1.38           | PREYSX2SA          |
| 1"        | PREYSX31          | 2.7            | 7.06  | 2.27 | 1.72           | PREYSX3SA          |
| 1-1/4"    | PREYSX41          | 3.7            | 8.75  | 3.08 | 2.31           | PREYSX4SA          |
| 1-1/2"    | PREYSX51          | 4.7            | 9.25  | 3.08 | 2.31           | PREYSX5SA          |
| 2"        | PREYSX61          | 6.7            | 12.50 | 4.33 | 3.31           | PREYSX6SA          |
| 2-1/2"    | PREYSX71          | 7.7            | 13.19 | 4.83 | 3.44           | PREYSX7SA          |
| 3"        | PREYSX81          | 8.7            | 13.75 | 5.33 | 3.69           | PREYSX8SA          |
| 3-1/2"    | PREYSX9           | 9.7            | 15.06 | 6.58 | 4.59           | PREYSX9SA          |
| 4"        | PREYSX10          | 10.7           | 15.06 | 6.58 | 4.59           | PREYSX10SA         |

**EYS - FEMALE HUBS**

**FOR SEALING IN VERTICAL POSITIONS ONLY**

| Pipe Size | FERROUS Catalog # | Nominal Weight | A    | B    | Turning Radius | Aluminum Catalog # |
|-----------|-------------------|----------------|------|------|----------------|--------------------|
| 1/2"      | PREYS1            | 1.0            | 4.28 | 1.33 | 1.63           | PREYS1SA           |
| 3/4"      | PREYS2            | 1.5            | 5.25 | 1.58 | 1.91           | PREYS2SA           |
| 1"        | PREYS3            | 2.1            | 6.31 | 1.83 | 2.38           | PREYS3SA           |

**FOR SEALING IN VERTICAL OR HORIZONTAL POSITIONS**

|        |         |      |       |      |      |           |
|--------|---------|------|-------|------|------|-----------|
| 1-1/4" | PREYS4  | 2.7  | 7.56  | 2.27 | 1.72 | PREYS4SA  |
| 1-1/2" | PREYS5  | 3.7  | 8.50  | 2.52 | 2.06 | PREYS5SA  |
| 2"     | PREYS6  | 4.7  | 10.25 | 3.08 | 2.31 | PREYS6SA  |
| 2-1/2" | PREYS7  | 10.0 | 11.50 | 3.58 | 2.69 | PREYS7SA  |
| 3"     | PREYS8  | 11.2 | 12.50 | 4.33 | 3.31 | PREYS8SA  |
| 3-1/2" | PREYS9  | 14.5 | 13.19 | 4.83 | 3.44 | PREYS9SA  |
| 4"     | PREYS10 | 16.0 | 13.75 | 5.33 | 3.69 | PREYS10SA |

**EYS - MALE/FEMALE HUBS**

**FOR SEALING IN VERTICAL POSITIONS ONLY**

| Pipe Size | FERROUS Catalog # | Nominal Weight | A    | B    | Turning Radius | Aluminum Catalog # |
|-----------|-------------------|----------------|------|------|----------------|--------------------|
| 1/2"      | PREYS16           | 1.5            | 4.78 | 1.33 | 1.63           | PREYS16SA          |
| 3/4"      | PREYS26           | 1.5            | 5.25 | 1.58 | 1.91           | PREYS26SA          |
| 1"        | PREYS36           | 2.3            | 6.31 | 1.83 | 2.38           | PREYS36SA          |

**EYS - FEMALE HUBS**

**FOR SEALING IN VERTICAL OR HORIZONTAL POSITIONS**

| Pipe Size | FERROUS Catalog # | Nominal Weight | A     | B    | Turning Radius | Aluminum Catalog # |
|-----------|-------------------|----------------|-------|------|----------------|--------------------|
| 1/2"      | PREYS11           | 1.3            | 4.69  | 1.33 | 1.16           | PREYS11SA          |
| 3/4"      | PREYS21           | 1.1            | 5.19  | 1.58 | 1.25           | PREYS21SA          |
| 1"        | PREYS31           | 2.2            | 6.31  | 1.83 | 1.38           | PREYS31SA          |
| 1-1/4"    | PREYS41           | 3.0            | 7.56  | 2.27 | 1.72           | PREYS41SA          |
| 1-1/2"    | PREYS51           | 3.8            | 8.50  | 2.52 | 2.06           | PREYS51SA          |
| 2"        | PREYS61           | 5.5            | 10.25 | 3.08 | 2.31           | PREYS61SA          |

**EYS - MALE/FEMALE HUBS FOR SEALING IN VERTICAL OR HORIZONTAL POSITIONS**

| Pipe Size | FERROUS Catalog # | Nominal Weight | A     | B    | Turning Radius | Aluminum Catalog # |
|-----------|-------------------|----------------|-------|------|----------------|--------------------|
| 1/2"      | PREYS116          | 1.5            | 5.19  | 1.33 | 1.16           | PREYS116SA         |
| 3/4"      | PREYS216          | 1.2            | 5.19  | 1.58 | 1.25           | PREYS216SA         |
| 1"        | PREYS316          | 2.6            | 6.31  | 1.83 | 1.38           | PREYS316SA         |
| 1-1/4"    | PREYS46           | 2.8            | 7.56  | 2.27 | 1.72           | PREYS46SA          |
| 1-1/2"    | PREYS56           | 3.7            | 8.50  | 2.52 | 2.06           | PREYS56SA          |
| 2"        | PREYS66           | 5.6            | 10.25 | 3.08 | 2.31           | PREYS66SA          |
| 2-1/2"    | PREYS76           | 13.2           | 11.50 | 3.58 | 2.69           | PREYS76SA          |
| 3"        | PREYS86           | 11.2           | 12.50 | 4.33 | 3.31           | PREYS86SA          |
| 3-1/2"    | PREYS96           | 14.5           | 13.19 | 4.83 | 3.44           | PREYS96SA          |
| 4"        | PREYS106          | 1.5            | 13.75 | 5.33 | 3.69           | PREYS96SA          |

Sealing Fittings continued on following pages...

## Sealing Fittings Technical Data

These PLASTI-BOND REDH<sub>2</sub>O<sub>T</sub> sealing fittings should be used with a suitable system of sealing compound, such as Chico A, Chico X or Chico A-P from Crouse-Hinds. Follow the installation instructions included with the sealing compound.

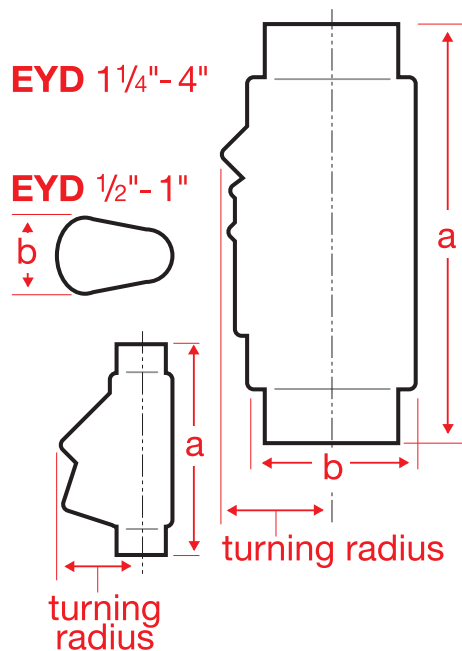

### **EYD - FEMALE HUBS WITH DRAIN.**

FOR SEALING IN VERTICAL POSITIONS ONLY.

| Pipe Size | FERROUS Catalog # | Nominal Weight | A     | B    | Turning Radius | Aluminum Catalog # |
|-----------|-------------------|----------------|-------|------|----------------|--------------------|
| 1/2"      | PREYD1            | 1.4            | 4.28  | 1.58 | 1.63           | PREYD1SA           |
| 3/4"      | PREYD2            | 1.7            | 5.19  | 1.83 | 1.91           | PREYD2SA           |
| 1"        | PREYD3            | 2.3            | 6.31  | 2.27 | 2.38           | PREYD3SA           |
| 1-1/4"    | PREYD4            | 2.5            | 7.56  | 2.27 | 1.84           | PREYD4SA           |
| 1-1/2"    | PREYD5            | 4.0            | 8.50  | 2.52 | 2.06           | PREYD5SA           |
| 2"        | PREYD6            | 4.7            | 10.25 | 3.08 | 2.31           | PREYD6SA           |
| 2-1/2"    | PREYD7            | 9.0            | 11.50 | 3.58 | 2.69           | PREYD7SA           |
| 3"        | PREYD8            | 10.2           | 12.50 | 4.33 | 3.31           | PREYD8SA           |
| 3-1/2"    | PREYD9            | 10.5           | 13.19 | 4.83 | 3.44           | PREYD9SA           |
| 4"        | PREYD10           | 4.0            | 13.75 | 5.33 | 3.50           | PREYD10SA          |

### **EYD - MALE/FEMALE HUBS WITH DRAIN.**

FOR SEALING IN VERTICAL POSITIONS ONLY.

| Pipe Size | FERROUS Catalog # | Nominal Weight | A     | B    | Turning Radius | Aluminum Catalog # |
|-----------|-------------------|----------------|-------|------|----------------|--------------------|
| 1/2"      | PREYD16           | 2.7            | 4.28  | 1.58 | 1.63           | PREYD16SA          |
| 3/4"      | PREYD26           | 2.8            | 5.19  | 1.83 | 1.91           | PREYD26SA          |
| 1"        | PREYD36           | 2.9            | 6.31  | 2.27 | 2.38           | PREYD36SA          |
| 1-1/4"    | PREYD46           | 2.6            | 7.56  | 2.27 | 1.84           | PREYD46SA          |
| 1-1/2"    | PREYD56           | 3.7            | 8.50  | 2.52 | 2.06           | PREYD56SA          |
| 2"        | PREYD66           | 5.2            | 10.25 | 3.08 | 2.31           | PREYD66SA          |
| 2-1/2"    | PREYD76           | 9.5            | 11.50 | 3.58 | 2.69           | PREYD76SA          |
| 3"        | PREYD86           | 11.3           | 12.50 | 4.33 | 3.31           | PREYD86SA          |
| 3-1/2"    | PREYD96           | 12.5           | 13.19 | 4.83 | 3.44           | PREYD96SA          |
| 4"        | PREYD106          | 16.7           | 13.75 | 5.33 | 3.50           | PREYD106SA         |

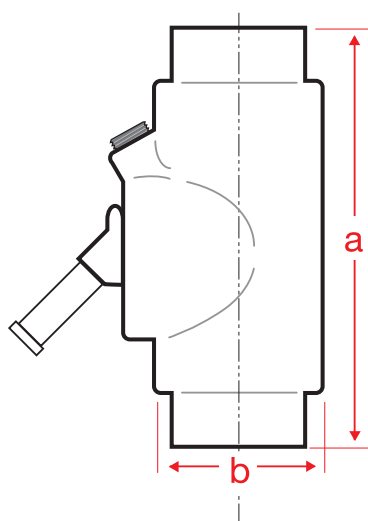

### **EYDX - EXPANDED FILL FEMALE HUBS WITH DRAIN.**

FOR SEALING IN VERTICAL POSITIONS ONLY.

| Pipe Size | FERROUS Catalog # | Nominal Weight | A     | B    | Turning Radius | Aluminum Catalog # |
|-----------|-------------------|----------------|-------|------|----------------|--------------------|
| 1/2"      | PREYDX11          | 1.7            | 4.69  | 1.83 | 1.91           | PREYDX1SA          |
| 3/4"      | PREYDX21          | 2.3            | 5.81  | 2.27 | 2.38           | PREYDX2SA          |
| 1"        | PREYDX31          | 2.5            | 7.06  | 2.27 | 1.84           | PREYDX3SA          |
| 1-1/4"    | PREYDX41          | 4.0            | 8.75  | 3.08 | 2.31           | PREYDX4SA          |
| 1-1/2"    | PREYDX51          | 4.7            | 9.25  | 3.08 | 2.31           | PREYDX5SA          |
| 2"        | PREYDX61          | 9.0            | 12.50 | 4.33 | 3.31           | PREYDX6SA          |
| 2-1/2"    | PREYDX71          | 10.2           | 13.19 | 4.83 | 3.44           | PREYDX7SA          |
| 3"        | PREYDX81          | 10.5           | 13.75 | 5.33 | 3.50           | PREYDX8SA          |

## Sealing Fittings Technical Data

These PLASTI-BOND REDH<sub>2</sub>O<sub>T</sub> sealing fittings should be used with a suitable system of sealing compound, such as Chico A, Chico X or Chico A-P from Crouse-Hinds. Follow the installation instructions included with the sealing compound.

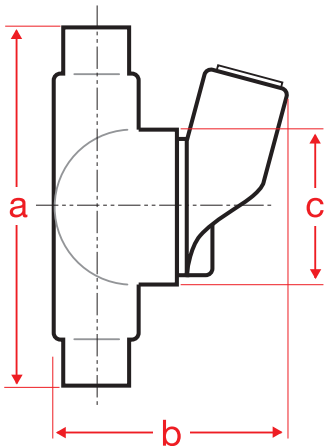

### EZS- FEMALE HUBS.

FOR SEALING IN ANY POSITION.

| Pipe Size | FERROUS Catalog # | Nominal Weight | A     | B    | C    | Turning Radius |
|-----------|-------------------|----------------|-------|------|------|----------------|
| 1/2"      | PREZS1            | 2.0            | 5.19  | 3.71 | 2.58 | 1.88           |
| 3/4"      | PREZS2            | 2.3            | 5.19  | 3.71 | 2.58 | 1.88           |
| 1"        | PREZS3            | 2.7            | 5.94  | 4.05 | 3.08 | 2.13           |
| 1-1/4"    | PREZS4            | 3.5            | 6.06  | 4.49 | 3.08 | 2.31           |
| 1-1/2"    | PREZS5            | 4.0            | 6.19  | 4.64 | 3.33 | 2.34           |
| 2"        | PREZS6            | 8.2            | 11.06 | 5.49 | 5.27 | 3.28           |
| 2-1/2"    | PREZS7            | 8.5            | 11.94 | 5.92 | 5.27 | 3.38           |
| 3"        | PREZS8            | 9.0            | 12.63 | 6.58 | 5.96 | 3.88           |

### EZS- MALE/FEMALE HUBS WITH DRAIN.

FOR SEALING IN ANY POSITION.

| Pipe Size | FERROUS Catalog # | Nominal Weight | A     | B    | C    | Turning Radius |
|-----------|-------------------|----------------|-------|------|------|----------------|
| 1/2"      | PREZS16           | 2.0            | 5.19  | 3.71 | 2.58 | 1.88           |
| 3/4"      | PREZS26           | 2.4            | 5.69  | 3.71 | 2.58 | 1.88           |
| 1"        | PREZS36           | 3.0            | 6.94  | 4.05 | 3.08 | 2.13           |
| 1-1/4"    | PREZS46           | 4.0            | 7.56  | 4.49 | 3.08 | 2.31           |
| 1-1/2"    | PREZS56           | 4.6            | 8.19  | 4.64 | 3.33 | 2.34           |
| 2"        | PREZS66           | 6.9            | 11.06 | 5.49 | 5.27 | 3.28           |
| 2-1/2"    | PREZS76           | 9.2            | 11.94 | 5.92 | 5.27 | 3.38           |
| 3"        | PREZS86           | 8.7            | 12.63 | 6.58 | 5.96 | 3.88           |

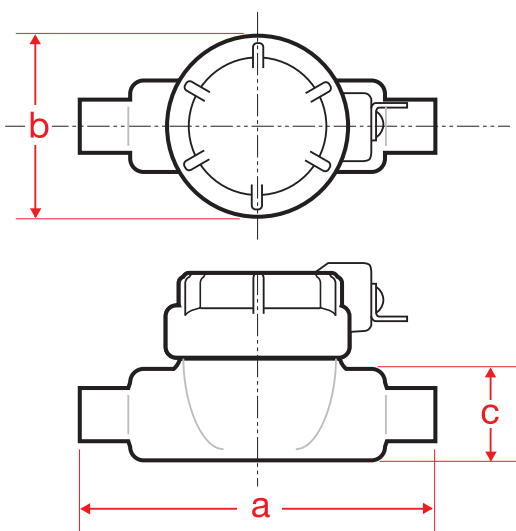

### EZD- FEMALE HUBS

WITH DRAIN AND INSPECTION COVER.

| Pipe Size | FERROUS Catalog # | Nominal Weight | A     | B    | C    | Turning Radius |
|-----------|-------------------|----------------|-------|------|------|----------------|
| 1/2"      | PREZD111          |                | 5.19  | 3.08 | 3.46 | 2.06           |
| 3/4"      | PREZD211          |                | 5.69  | 3.08 | 3.71 | 2.19           |
| 1"        | PREZD311          |                | 6.94  | 3.58 | 3.96 | 2.44           |
| 1-1/4"    | PREZD411          |                | 7.44  | 3.58 | 4.39 | 2.63           |
| 1-1/2"    | PREZD511          |                | 8.19  | 3.58 | 4.64 | 2.69           |
| 2"        | PREZD611          |                | 11.13 | 5.64 | 5.33 | 3.69           |

# PLASTI-BOND REDH<sub>2</sub>OT KNOCKOUT HUBS

## KNOCKOUT HUBS



PRST



PRSTG

### Knockout Hubs Configurations

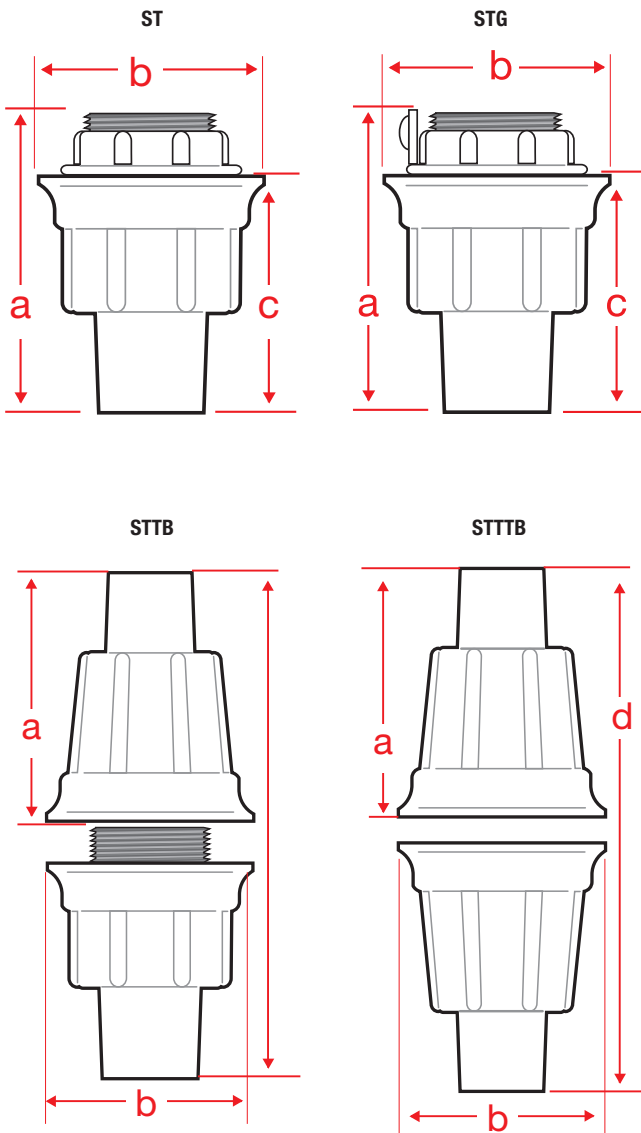

### Knockout Hubs Specifications

PLASTI-BOND REDH<sub>2</sub>OT ST style knockout hubs are used to terminate conduit runs through the wall of a sheet metal electrical enclosure. They are available with or without grounding lug. STTB style hubs are "Through-Bulkhead" fittings used to pass conduit runs through firewalls or bulkheads up to 1/8" thick. STTTB style hubs perform the same function for unlimited wall thicknesses, (furnished without nipples).

#### APPLICATION

#### FEATURES

#### COMPLIANCES

- 40 mil gray PVC exterior coating
- 2 mil red urethane interior coating
- ST and STTB available in 12 trade sizes from 1/2" through 6"
- STTTB in 6 trade sizes from 1/2" through 2".
- Sealing sleeves on conduit side of hub
- Molded PVC gasket seals flush with enclosure wall.
- O-ring gasket provides additional seal

#### Steel Only: ST, STG

- UL 514B (E200413)
- NEC/CEC:  
Class I, Division 2  
Class II, Division 1 & 2  
Class III, Division 1 & 2

#### NOTE:

- All Screw-tight Hubs are listed for NEMA and UL type enclosures 2, 3, 3R, 4, 4x, 11 and 12
- Grounding and Bonding Hubs are listed for NEMA Enclosures 2, 3, 3R, 4 and 12

#### APPROVAL STAMP

(See online product submittal guide at [www.plastibond.com](http://www.plastibond.com))



## Knockout Hubs Technical Data

### ST

| Pipe Size | Catalog # | Nominal Weight | A    | B    | C    | MAX WALL THICK | Aluminum Catalog # |
|-----------|-----------|----------------|------|------|------|----------------|--------------------|
| 1/2"      | PRST1     | 0.2            | 1.84 | 2.00 | 1.31 | 0.125          | PRSTA1             |
| 3/4"      | PRST2     | 0.3            | 2.22 | 2.25 | 1.66 | 0.125          | PRSTA2             |
| 1"        | PRST3     | 0.4            | 2.66 | 2.50 | 2.03 | 0.125          | PRSTA3             |
| 1-1/4"    | PRST4     | 0.4            | 2.94 | 3.25 | 2.28 | 0.125          | PRSTA4             |
| 1-1/2"    | PRST5     | 0.6            | 3.19 | 3.50 | 2.53 | 0.125          | PRSTA5             |
| 2"        | PRST6     | 1.2            | 3.75 | 4.25 | 3.09 | 0.125          | PRSTA6             |
| 2-1/2"    | PRST7     | 1.5            | 4.22 | 4.75 | 3.28 | 0.125          | PRSTA7             |
| 3"        | PRST8     | 2.1            | 4.31 | 5.25 | 3.38 | 0.125          | PRSTA8             |
| 3-1/2"    | PRST9     | 3.0            | 4.38 | 5.50 | 3.44 | 0.125          | PRSTA9             |
| 4"        | PRST10    | 3.5            | 4.44 | 6.25 | 3.50 | 0.125          | PRSTA10            |
| 5"        | PRST11    | 5.4            | 4.94 | 7.50 | 4.00 | 0.125          | PRSTA11            |
| 6"        | PRST12    | 6.9            | 5.00 | 8.50 | 4.00 | 0.125          | PRSTA12            |

### STG

| Pipe Size | Catalog # | Nominal Weight | A    | B    | C    | MAX WALL THICK | Aluminum Catalog # |
|-----------|-----------|----------------|------|------|------|----------------|--------------------|
| 1/2"      | PRSTG1    | 0.2            | 1.84 | 2.00 | 1.31 | 0.125          | PRSTAG1            |
| 3/4"      | PRSTG2    | 0.3            | 2.22 | 2.25 | 1.66 | 0.125          | PRSTAG2            |
| 1"        | PRSTG3    | 0.4            | 2.66 | 2.50 | 2.03 | 0.125          | PRSTAG3            |
| 1-1/4"    | PRSTG4    | 0.4            | 2.94 | 3.25 | 2.28 | 0.125          | PRSTAG4            |
| 1-1/2"    | PRSTG5    | 0.6            | 3.19 | 3.50 | 2.53 | 0.125          | PRSTAG5            |
| 2"        | PRSTG6    | 1.2            | 3.75 | 4.25 | 3.09 | 0.125          | PRSTAG6            |
| 2-1/2"    | PRSTG7    | 1.5            | 4.22 | 4.75 | 3.28 | 0.125          | PRSTAG7            |
| 3"        | PRSTG8    | 2.1            | 4.31 | 5.25 | 3.38 | 0.125          | PRSTAG8            |
| 3-1/2"    | PRSTG9    | 3.0            | 4.38 | 5.50 | 3.44 | 0.125          | PRSTAG9            |
| 4"        | PRSTG10   | 3.5            | 4.44 | 6.25 | 3.50 | 0.125          | PRSTAG10           |
| 5"        | PRSTG11   | 5.4            | 4.94 | 7.50 | 4.00 | 0.125          | PRSTAG11           |
| 6"        | PRSTG12   | 6.9            | 5.00 | 8.50 | 4.00 | 0.125          | PRSTAG12           |

### STTB

| Pipe Size | Catalog # | Nominal Weight | A    | B    | D    | MAX WALL THICK | Aluminum Catalog # |
|-----------|-----------|----------------|------|------|------|----------------|--------------------|
| 1/2"      | PRSTTB1   | 0.5            | 1.84 | 2.00 | 3.68 | 0.19           | PRSTTB1            |
| 3/4"      | PRSTTB2   | 0.5            | 2.22 | 2.25 | 4.44 | 0.19           | PRSTTB2            |
| 1"        | PRSTTB3   | 0.7            | 2.66 | 2.50 | 5.32 | 0.25           | PRSTTB3            |
| 1-1/4"    | PRSTTB4   | 1.0            | 2.94 | 3.25 | 5.88 | 0.25           | PRSTTB4            |
| 1-1/2"    | PRSTTB5   | 1.2            | 3.19 | 3.50 | 6.38 | 0.25           | PRSTTB5            |
| 2"        | PRSTTB6   | 1.7            | 3.75 | 4.25 | 7.50 | 0.25           | PRSTTB6            |
| 2-1/2"    | PRSTTB7   | 2.5            | 4.22 | 4.75 | 8.44 | 0.25           | PRSTTB7            |
| 3"        | PRSTTB8   | 3.0            | 4.31 | 5.25 | 8.62 | 0.25           | PRSTTB8            |
| 3-1/2"    | PRSTTB9   | 4.2            | 4.38 | 5.50 | 8.76 | 0.25           | PRSTTB9            |
| 4"        | PRSTTB10  | 5.9            | 4.44 | 6.25 | 8.88 | 0.25           | PRSTTB10           |

### STTTB

| Pipe Size | Catalog # | Nominal Weight | A    | B    | D    | MAX WALL THICK | Aluminum Catalog # |
|-----------|-----------|----------------|------|------|------|----------------|--------------------|
| 1/2"      | PRSTTTB1  | 1.0            | 1.84 | 2.00 | 3.68 | *              | PRSTTTB1           |
| 3/4"      | PRSTTTB2  | 1.0            | 2.22 | 2.25 | 4.44 | *              | PRSTTTB2           |
| 1"        | PRSTTTB3  | 1.4            | 2.66 | 2.50 | 5.32 | *              | PRSTTTB3           |
| 1-1/4"    | PRSTTTB4  | 2.0            | 2.94 | 3.25 | 5.88 | *              | PRSTTTB4           |
| 1-1/2"    | PRSTTTB5  | 2.4            | 3.19 | 3.50 | 6.38 | *              | PRSTTTB5           |
| 2"        | PRSTTTB6  | 3.4            | 3.75 | 4.25 | 7.50 | *              | PRSTTTB6           |

\* Unlimited wall thickness – determined by nipple used.



## REDH<sub>2</sub>OT PRODUCT FLASH

### Proper Product Performance Depends On Proper Installation... And We Can Help!

We support proper installation of Plasti-Bond REDH<sub>2</sub>OT in many ways. **First:** we make available to you, at no charge, a comprehensive installation manual plus an installation video (available in English and Spanish). **Second,** we recommend Corrosion College, an intense, two day educational experience that covers installation procedures in addition to topics related to corrosion theory and prevention.

**Third:** we provide specialized tools to ensure that installation can be performed quickly, easily, and without damage. **Fourth:** we provide an installer certification program that teaches proper installation techniques for maximum conduit performance.

# PLASTI-BOND REDH<sub>2</sub>OT CONDUIT UNIONS

## CONDUIT UNIONS

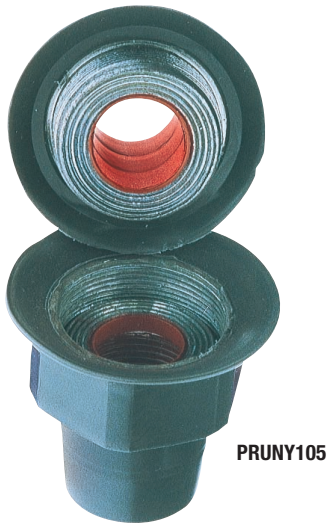

PRUNY105

### Conduit Union Technical Data

#### UNF

| Pipe Size   | FERROUS Catalog # | Nominal Weight | Length | Max Dia. | Aluminum Catalog # |
|-------------|-------------------|----------------|--------|----------|--------------------|
| 1/2"        | PRUNF105          | 0.3            | 2.81   | 1.58     | PRUNF105SA         |
| 3/4"        | PRUNF205          | 0.5            | 3.25   | 1.89     | PRUNF205SA         |
| 3/4" - 1/2" | PRUNF215          | 0.6            | 3.00   | 1.89     | -                  |
| 1"          | PRUNF305          | 0.7            | 4.00   | 1.96     | PRUNF305SA         |
| 1-1/4"      | PRUNF405          | 1.5            | 4.75   | 2.83     | PRUNF405SA         |
| 1-1/2"      | PRUNF505          | 2.3            | 5.63   | 3.14     | PRUNF505SA         |
| 2"          | PRUNF605          | 3.6            | 6.56   | 3.89     | PRUNF605SA         |
| 2-1/2"      | PRUNF705          | 5.0            | 7.19   | 4.39     | PRUNF705SA         |
| 3"          | PRUNF805          | 6.5            | 7.44   | 5.14     | PRUNF805SA         |
| 3-1/2"      | PRUNF905          | 8.2            | 8.13   | 5.77     | PRUNF905SA         |
| 4"          | PRUNF1005         | 10.0           | 8.13   | 6.27     | PRUNF1005SA        |
| 5"          | PRUNF012          | 12.5           | 7.81   | 8.27     | -                  |
| 6"          | PRUNF014          | 14.8           | 7.81   | 9.39     | -                  |

#### UNY

| Pipe Size   | FERROUS Catalog # | Nominal Weight | Length | Max Dia. | Aluminum Catalog # |
|-------------|-------------------|----------------|--------|----------|--------------------|
| 1/2"        | PRUNY105          | 0.4            | 3.38   | 1.58     | PRUNY105SA         |
| 3/4"        | PRUNY205          | 0.7            | 3.94   | 1.89     | PRUNY205SA         |
| 3/4" - 1/2" | PRUNY215          | 0.8            | 3.69   | 1.89     | -                  |
| 1"          | PRUNY305          | 1.3            | 4.75   | 1.96     | PRUNY305SA         |
| 1-1/4"      | PRUNY405          | 2.6            | 5.69   | 2.83     | PRUNY405SA         |
| 1-1/2"      | PRUNY505          | 3.9            | 6.56   | 3.14     | PRUNY505SA         |
| 2"          | PRUNY605          | 4.2            | 7.75   | 3.89     | PRUNY605SA         |
| 2-1/2"      | PRUNY705          | 5.5            | 8.63   | 4.39     | PRUNY705SA         |
| 3"          | PRUNY805          | 7.5            | 9.00   | 5.14     | PRUNY805SA         |
| 3-1/2"      | PRUNY905          | 8.4            | 9.50   | 5.77     | PRUNY905SA         |
| 4"          | PRUNY1005         | 10.5           | 9.63   | 6.27     | PRUNY1005SA        |
| 5"          | PRUNY012          | 12.0           | 9.25   | 8.27     | -                  |
| 6"          | PRUNY014          | 14.9           | 9.38   | 9.39     | -                  |

### Conduit Union Technical Data

#### APPLICATION

PLASTI-BOND REDH<sub>2</sub>OT UNF unions are used to connect conduit to conduit or to allow for future changes to the conduit system. Female threads are provided at each end. PLASTI-BOND REDH<sub>2</sub>OT UNY unions are used to connect conduit to a conduit fitting, junction box, or device enclosure. One end is a male thread and the other is female.

#### FEATURES

- 40 mil gray PVC exterior coating
- 2 mil red urethane interior coating
- 13 trade sizes from 1/2" through 6".
- Sealing sleeves on all conduit openings
- Molded PVC gasket seals fitting

#### COMPLIANCES

- NEC/CEC:
- UNF/UNY 1/2" through 1"
  - Class I, Division 1 & 2, Groups A, B, C, D
  - Class II, Division 1, Groups E, F, G
  - Class II, Division 2, Groups F, G
  - Class III
- UNF/UNY 905, 1005
  - Class I, Division 1 & 2, Groups B, C, D
  - Class II, Division 1, Groups E, F, G
  - Class II, Division 2, Groups F, G
  - Class III
- UNF, UNY - all sizes
  - Class I, Division 1 & 2, Groups C, D
  - Class II, Division 1, Groups E, F, G
  - Class II, Division 2, Groups F, G
  - Class III

### Conduit Union Configurations

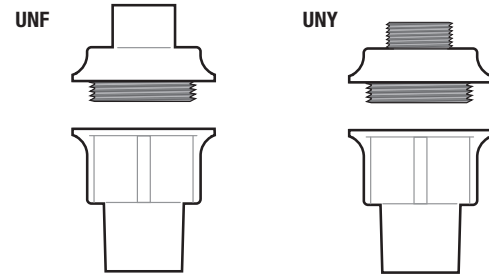

#### APPROVAL STAMP

(See online product submittal guide at [www.plastibond.com](http://www.plastibond.com))

# PLASTI-BOND REDH<sub>2</sub>O<sub>T</sub> MALLEABLE ELBOWS

## MALLEABLE ELBOWS



PREL195

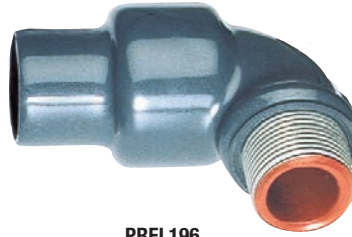

PREL196



PREL19

### Malleable Elbows Technical Data

#### MALLEABLE ELBOWS 90° MALE-MALE

| Pipe Size | FERROUS CATALOG # | A    | Nominal Weight |
|-----------|-------------------|------|----------------|
| 1/2"      | PREL195           | 1.44 | 0.3            |
| 3/4"      | PREL295           | 1.63 | 0.5            |
| 1"        | PREL395           | 1.88 | 0.7            |

#### MALLEABLE ELBOWS 90° FEMALE-FEMALE

| Pipe Size | FERROUS CATALOG # | A    | Nominal Weight | ALUMINUM CATALOG # |
|-----------|-------------------|------|----------------|--------------------|
| 1/2"      | PREL19            | 2.03 | 0.7            | PREL19SA           |
| 3/4"      | PREL29            | 2.50 | 0.9            | PREL29SA           |
| 1"        | PREL39            | 3.00 | 1.2            | PREL39SA           |
| 1-1/4"    | PREL49            | 3.50 | 2.4            | PREL49SA           |
| 1-1/2"    | PREL59            | 5.50 | 3.0            | PREL59SA           |
| 2"        | PREL69            | 7.00 | 6.0            | PREL69SA           |
| 2-1/2"    | PREL79            | 8.44 | 7.9            | -                  |

#### MALLEABLE ELBOWS 90° MALE-FEMALE

| Pipe Size | FERROUS CATALOG # | A    | Nominal Weight | ALUMINUM CATALOG # |
|-----------|-------------------|------|----------------|--------------------|
| 1/2"      | PREL196           | 2.03 | 0.3            | PREL196SA          |
| 3/4"      | PREL296           | 2.38 | 0.5            | PREL296SA          |
| 1"        | PREL396           | 2.88 | 1.2            | PREL396SA          |

### Malleable Elbows Configurations

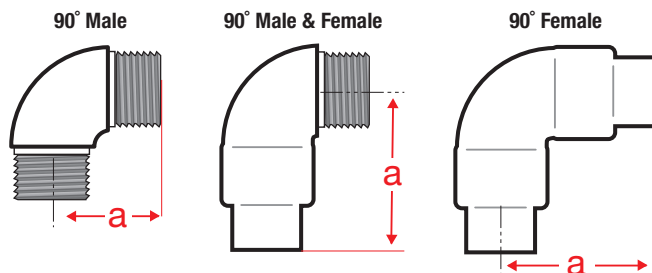

### Malleable Elbows Specifications

#### APPLICATION

PLASTI-BOND REDH<sub>2</sub>O<sub>T</sub> EL style malleable elbows are used in a conduit run to change direction 90° or to terminate at a fitting or box. They are available with male threads only, female threads only, or male and female threads.

#### FEATURES

- 40 mil gray PVC exterior coating
- 2 mil red urethane interior coating
- Various configurations in 10 trade sizes from 1/2" through 4".
- Sealing sleeves on all conduit openings

#### COMPLIANCES

- NEC/CEC  
1/2", 3/4", 1"  
Class I, Division 1 & 2, Groups A, B, C, D  
Class II, Division 1, Groups E, F, G  
Class II, Division 2, Groups F, G  
Class III
- All sizes  
Class I, Division 1 & 2, Groups C, D  
Class II, Division 1, Groups E, F, G  
Class II, Division 2, Groups F, G  
Class III

#### APPROVAL STAMP

(See online product submittal guide at [www.plastibond.com](http://www.plastibond.com))

# PLASTI-BOND REDH<sub>2</sub>OT SERVICE ENTRANCE ELBOWS

## SERVICE ENTRANCE ELBOWS



PRLBY1

### LBY Series Specifications

### LBY Series Dimensions

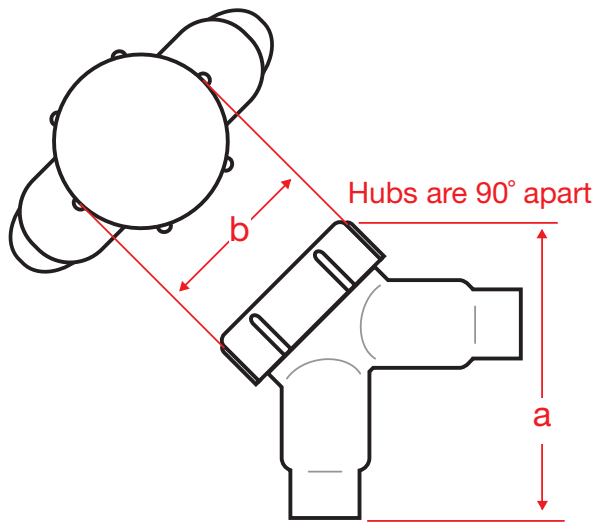

#### APPLICATION

PLASTI-BOND REDH<sub>2</sub>OT LBY type elbows are used as service entrance elbows between service entrance and vertical weatherhead conduit runs, to change direction of a conduit run 90° when space is limited, and for pull outlets. They may be used for general service or hazardous locations.

#### FEATURES

- 40 mil gray PVC exterior coating
- 2 mil red urethane interior coating
- 5 trade sizes from 1/2" through 1-1/2".
- Sealing sleeves on all conduit openings
- Molded PVC gasket seals fitting cover to body

#### COMPLIANCES

- Series PRLBY15 through PRLBY55
- NEC/CEC  
Class I, Division 1 & 2, Groups C, D  
Class II, Division 1, Groups E, F, G  
Class II, Division 2, Groups F, G  
Class III

### LBY SERIES - FOR HAZARDOUS LOCATIONS

| Pipe Size | FERROUS Catalog # | A    | B    | Nominal Weight | Aluminum Catalog # |
|-----------|-------------------|------|------|----------------|--------------------|
| 1/2"      | PRLBY15           | 3.10 | 2.08 | 1.0            | PRLBY15SA          |
| 3/4"      | PRLBY25           | 3.60 | 2.33 | 1.2            | PRLBY25SA          |
| 1"        | PRLBY35           | 4.13 | 2.58 | 1.7            | PRLBY35SA          |
| 1-1/4"    | PRLBY45           | 5.04 | 3.02 | 2.5            | PRLBY45SA          |
| 1-1/2"    | PRLBY55           | 5.79 | 3.46 | 2.7            | PRLBY55SA          |

#### APPROVAL STAMP

(See online product submittal guide at [www.plastibond.com](http://www.plastibond.com))



# PLASTI-BOND REDH<sub>2</sub>O<sub>T</sub> CONDUIT EXPANSION JOINTS

## EXPANSION JOINTS



PRXJG64

### Conduit Expansion Joints Dimensions

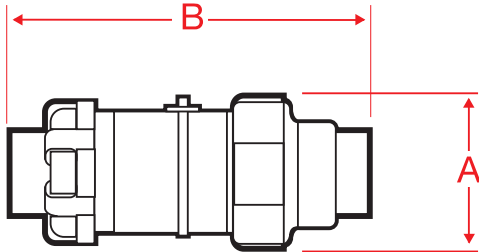

#### 4" TRAVEL XJG SERIES

| Pipe Size | FERROUS Catalog # | A    | B     | Nominal Weight | Aluminum Catalog # |
|-----------|-------------------|------|-------|----------------|--------------------|
| 1/2"      | PRXJG14           | 1.83 | 7.75  | 1.5            | PRXJG14SA          |
| 3/4"      | PRXJG24           | 2.20 | 8.25  | 2.9            | PRXJG24SA          |
| 1"        | PRXJG34           | 2.51 | 9.25  | 3.6            | PRXJG34SA          |
| 1-1/4"    | PRXJG44           | 3.27 | 10.06 | 3.8            | PRXJG44SA          |
| 1-1/2"    | PRXJG54           | 3.76 | 10.87 | 6.2            | PRXJG54SA          |
| 2"        | PRXJG64           | 4.83 | 12.25 | 7.3            | PRXJG64SA          |
| 2-1/2"    | PRXJG74           | 4.95 | 13.31 | 9.8            | PRXJG74SA          |
| 3"        | PRXJG84           | 5.45 | 14.00 | 13.6           | PRXJG84SA          |
| 3-1/2"    | PRXJG94           | 6.70 | 13.81 | 16.1           | PRXJG94SA          |
| 4"        | PRXJG104          | 6.70 | 13.81 | 22.5           | PRXJG104SA         |

#### 8" TRAVEL XJG SERIES

| Pipe Size | FERROUS Catalog # | A    | B     | Nominal Weight | Aluminum Catalog # |
|-----------|-------------------|------|-------|----------------|--------------------|
| 1/2"      | PRXJG18           | 1.83 | 11.75 | 1.9            | PRXJG18SA          |
| 3/4"      | PRXJG28           | 2.20 | 12.25 | 3.0            | PRXJG28SA          |
| 1"        | PRXJG38           | 2.51 | 13.25 | 3.3            | PRXJG38SA          |
| 1-1/4"    | PRXJG48           | 3.27 | 14.06 | 4.7            | PRXJG48SA          |
| 1-1/2"    | PRXJG58           | 3.76 | 14.87 | 7.3            | PRXJG58SA          |
| 2"        | PRXJG68           | 4.83 | 16.25 | 10.7           | PRXJG68SA          |
| 2-1/2"    | PRXJG78           | 4.95 | 17.31 | 14.4           | PRXJG78SA          |
| 3"        | PRXJG88           | 5.45 | 18.00 | 15.9           | PRXJG88SA          |
| 3-1/2"    | PRXJG98           | 6.70 | 17.81 | 23.8           | PRXJG98SA          |
| 4"        | PRXJG108          | 6.70 | 17.81 | 25.7           | PRXJG108SA         |

### Conduit Expansion Joints Specifications

#### APPLICATION

PLASTI-BOND REDH<sub>2</sub>O<sub>T</sub> XJG type expansion joints are used to connect two lengths of conduit subject to longitudinal movement, including that caused in long runs by thermal expansion and contraction.

#### FEATURES

- 40 mil gray PVC exterior coating
- 2 mil red urethane interior coating
- 10 trade sizes from 1/2" through 4".
- Sealing sleeves on all conduit openings
- Available with either 4" or 8" maximum movement
- Internally Grounded

#### COMPLIANCES

- NEC Article 250-77
- NEC Article 300-7 (b)
- NEMA FB1

#### APPROVAL STAMP

(See online product submittal guide at [www.plastibond.com](http://www.plastibond.com))

# PLASTI-BOND REDH<sub>2</sub>O<sub>T</sub> LIQUID TIGHT CONNECTORS

## LIQUID TIGHT CONNECTORS



PR5352

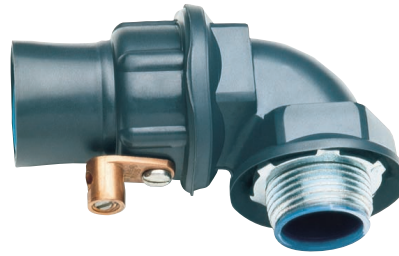

PR5352GR



PR5332



PR5342

### Liquid Tight Connectors Configurations

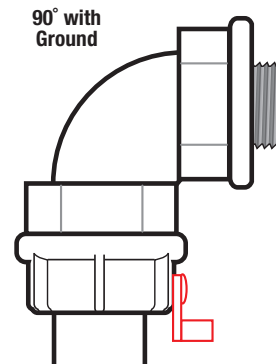
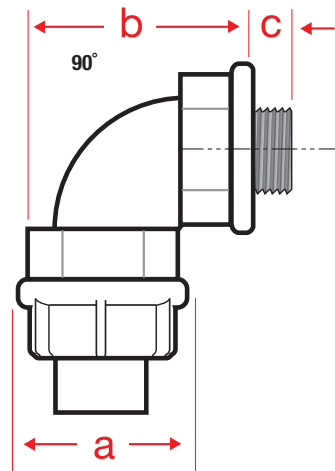

### Liquid Tight Connectors Specifications

#### APPLICATION

PLASTI-BOND REDH<sub>2</sub>O<sub>T</sub> liquid tight connectors are used with liquid tight conduit to wire motors, transformers, processing equipment, pumps, etc.. The flexible conduit and the PVC coated connector work together to seal out water and other corrosive liquids, protecting the conductors from damage.

#### FEATURES

- 40 mil gray PVC exterior coating
- 2 mil red urethane interior coating
- 13 trade sizes from 3/8" through 6".
- Sealing sleeves on all conduit openings
- Available in straight, 45° or 90° body configurations
- Available with an external grounding lug

#### COMPLIANCES

- Steel Fittings Only**
- UL 514B (E200413), UL 467 (E217890)

#### APPROVAL STAMP

(See online product submittal guide at [www.plastibond.com](http://www.plastibond.com))

# LIQUID TIGHT CONNECTORS

## STRAIGHT CONNECTOR

| Pipe Size | FERROUS Catalog # | A    | B    | C    | Nominal Weight | Aluminum Catalog # |
|-----------|-------------------|------|------|------|----------------|--------------------|
| 3/8"      | PR5331            | 1.24 | 1.88 | 0.56 | 0.2            | PR5231AL           |
| 1/2"      | PR5332            | 1.46 | 2.06 | 0.56 | 0.2            | PR5232AL           |
| 3/4"      | PR5333            | 1.74 | 2.38 | 0.56 | 0.3            | PR5233AL           |
| 1"        | PR5334            | 1.96 | 3.06 | 0.75 | 0.4            | PR5234AL           |
| 1-1/4"    | PR5335            | 2.36 | 3.75 | 0.81 | 0.8            | PR5235AL           |
| 1-1/2"    | PR5336            | 2.80 | 4.19 | 0.81 | 0.9            | PR5236AL           |
| 2"        | PR5337            | 3.33 | 5.06 | 0.88 | 1.7            | PR5237AL           |
| 2-1/2"    | PR5338            | 3.83 | 6.13 | 1.00 | 3.0            | PR5238AL           |
| 3"        | PR5339            | 4.58 | 6.25 | 1.00 | 4.2            | PR5239AL           |
| 4"        | PR5340            | 5.58 | 6.50 | 1.13 | 6.2            | PR5240AL           |

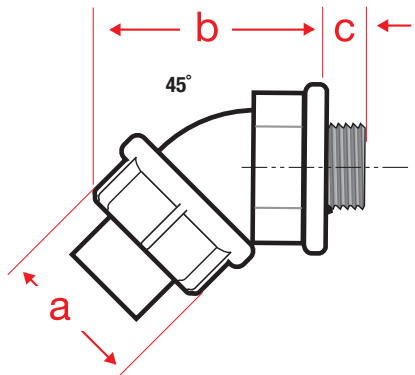

## STRAIGHT CONNECTOR WITH GROUND

| Pipe Size | FERROUS Catalog # | A    | B    | C    | Ground Wire | Nominal Weight | Aluminum Catalog # |
|-----------|-------------------|------|------|------|-------------|----------------|--------------------|
| 3/8"      | PR5331GR          | 1.24 | 1.88 | 0.56 | 14-8        | 0.2            | PR5231GRAL         |
| 1/2"      | PR5332GR          | 1.46 | 2.06 | 0.56 | 14-8        | 0.2            | PR5232GRAL         |
| 3/4"      | PR5333GR          | 1.74 | 2.38 | 0.56 | 14-4        | 0.3            | PR5233GRAL         |
| 1"        | PR5334GR          | 1.96 | 3.06 | 0.75 | 14-4        | 0.4            | PR5234GRAL         |
| 1-1/4"    | PR5335GR          | 2.33 | 3.75 | 0.81 | 8/2/04      | 0.8            | PR5235GRAL         |
| 1-1/2"    | PR5336GR          | 3.33 | 4.19 | 0.81 | 4/3/04      | 0.9            | PR5236GRAL         |
| 2"        | PR5337GR          | 3.89 | 5.06 | 0.88 | 4/3/04      | 1.7            | PR5237GRAL         |
| 2-1/2"    | PR5338GR          | 4.52 | 6.13 | 1.00 | 2/5/04      | 3.0            | PR5238GRAL         |
| 3"        | PR5339GR          | 5.27 | 6.25 | 1.00 | 2/5/04      | 4.2            | PR5239GRAL         |
| 4"        | PR5340GR          | 6.21 | 6.50 | 1.13 | 2/5/04      | 6.2            | PR5240GRAL         |

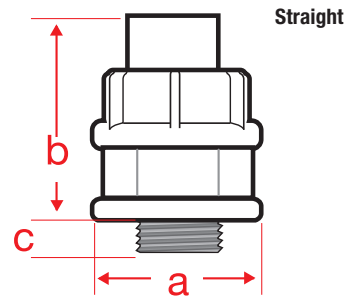

## 45° CONNECTOR

| Pipe Size | FERROUS Catalog # | A    | B    | C    | Nominal Weight |
|-----------|-------------------|------|------|------|----------------|
| 3/8"      | PR5341            | 1.24 | 1.94 | 0.56 | 0.3            |
| 1/2"      | PR5342            | 1.46 | 2.38 | 0.56 | 0.3            |
| 3/4"      | PR5343            | 1.74 | 2.88 | 0.56 | 0.4            |
| 1"        | PR5344            | 1.96 | 3.25 | 0.75 | 0.5            |
| 1-1/4"    | PR5345            | 2.36 | 4.00 | 0.81 | 1.5            |
| 1-1/2"    | PR5346            | 2.80 | 4.88 | 0.81 | 1.2            |
| 2"        | PR5347            | 3.33 | 5.88 | 0.88 | 2.0            |
| 2-1/2"    | PR5348            | 3.83 | 6.25 | 1.00 | 3.0            |
| 3"        | PR5349            | 4.58 | 6.25 | 1.00 | 4.2            |
| 4"        | PR5350            | 5.58 | 6.63 | 1.13 | 6.2            |

## 45° CONNECTOR WITH GROUND

| Pipe Size | FERROUS Catalog # | A    | B    | C    | Ground Wire | Nominal Weight |
|-----------|-------------------|------|------|------|-------------|----------------|
| 3/8"      | PR5341GR          | 1.24 | 1.94 | 0.56 | 14-8        | 0.3            |
| 1/2"      | PR5342GR          | 1.46 | 2.38 | 0.56 | 14-8        | 0.3            |
| 3/4"      | PR5343GR          | 1.74 | 2.88 | 0.56 | 14-4        | 0.4            |
| 1"        | PR5344GR          | 1.96 | 3.25 | 0.75 | 14-4        | 0.5            |
| 1-1/4"    | PR5345GR          | 3.33 | 4.63 | 0.81 | 4/3/04      | 1.5            |
| 1-1/2"    | PR5346GR          | 3.33 | 4.88 | 0.81 | 4/3/04      | 1.2            |
| 2"        | PR5347GR          | 3.89 | 5.88 | 0.88 | 4/3/04      | 2.0            |
| 2-1/2"    | PR5348GR          | 4.52 | 6.25 | 1.00 | 2/5/04      | 3.0            |
| 3"        | PR5349GR          | 5.27 | 6.25 | 1.00 | 2/5/04      | 4.2            |
| 4"        | PR5350GR          | 6.21 | 6.63 | 1.13 | 2/5/04      | 6.2            |

## 90° CONNECTOR

| Pipe Size | FERROUS Catalog # | A    | B     | C    | Nominal Weight | Aluminum Catalog # |
|-----------|-------------------|------|-------|------|----------------|--------------------|
| 3/8"      | PR5351            | 1.24 | 1.80  | 0.56 | 0.3            | PR5251AL           |
| 1/2"      | PR5352            | 1.46 | 2.10  | 0.56 | 0.3            | PR5252AL           |
| 3/4"      | PR5353            | 1.74 | 2.54  | 0.56 | 0.4            | PR5253AL           |
| 1"        | PR5354            | 1.96 | 3.23  | 0.75 | 0.6            | PR5254AL           |
| 1-1/4"    | PR5355            | 2.36 | 4.04  | 0.81 | 1.0            | PR5255AL           |
| 1-1/2"    | PR5356            | 2.80 | 4.48  | 0.81 | 1.7            | PR5256AL           |
| 2"        | PR5357            | 3.33 | 5.48  | 0.88 | 2.7            | PR5257AL           |
| 2-1/2"    | PR5358            | 3.83 | 10.92 | 1.00 | 3.8            | -                  |
| 3"        | PR5359            | 4.58 | 12.29 | 1.00 | 4.2            | -                  |
| 4"        | PR5360            | 5.58 | 14.67 | 1.13 | 6.2            | -                  |

## 90° CONNECTOR WITH GROUND

| Pipe Size | FERROUS Catalog # | A    | B     | C    | Ground Wire | Nominal Weight | Aluminum Catalog # |
|-----------|-------------------|------|-------|------|-------------|----------------|--------------------|
| 3/8"      | PR5351GR          | 1.10 | 1.55  | 0.56 | 14-8        | 0.3            | PR5251GRAL         |
| 1/2"      | PR5352GR          | 1.46 | 1.98  | 0.56 | 14-8        | 0.3            | PR5252GRAL         |
| 3/4"      | PR5353GR          | 1.96 | 2.85  | 0.75 | 14-4        | 0.4            | PR5253GRAL         |
| 1"        | PR5354GR          | 1.96 | 3.10  | 0.75 | 14-4        | 0.6            | PR5254GRAL         |
| 1-1/4"    | PR5355GR          | 2.33 | 3.79  | 0.81 | 8/2/04      | 1.0            | PR5255GRAL         |
| 1-1/2"    | PR5356GR          | 3.33 | 4.48  | 0.81 | 4/3/04      | 1.7            | PR5256GRAL         |
| 2"        | PR5357GR          | 3.89 | 5.48  | 0.88 | 4/3/04      | 2.7            | PR5257GRAL         |
| 2-1/2"    | PR5358GR          | 4.52 | 10.92 | 1.00 | 2/5/04      | 3.8            | -                  |
| 3"        | PR5359GR          | 5.27 | 12.29 | 1.00 | 2/5/04      | 4.2            | -                  |
| 4"        | PR5360GR          | 6.21 | 14.67 | 1.13 | 2/5/04      | 6.2            | -                  |

# PLASTI-BOND REDH<sub>2</sub>O<sub>T</sub> REDUCING AND SPLIT COUPLINGS

## REDUCING AND SPLIT COUPLINGS

### Reducing Couplings Specifications

#### APPLICATION

PLASTI-BOND REDH<sub>2</sub>O<sub>T</sub> reducing couplings are used to connect two pieces of conduit of different size. They are available in 17 different size combinations.

#### FEATURES

- 40 mil gray PVC exterior coating
- 2 mil red urethane interior coating
- 17 trade sizes from 1/2" through 4".
- Sealing sleeves on all conduit openings

#### COMPLIANCES

- NEC/CEC:  
Class I, Division 1 & 2, Groups A, B, C, D  
Class II, Division 1, Groups E, F, G  
Class II, Division 2, Groups F, G  
Class III



PRREC32

### REDUCING COUPLINGS

| Pipe Size       | FERROUS Catalog # | Nominal Weight | Aluminum Catalog # |
|-----------------|-------------------|----------------|--------------------|
| 3/4" – 1/2"     | PRREC21           | 0.2            | PRREC21SA          |
| 1" – 1/2"       | PRREC31           | 0.7            | PRREC31SA          |
| 1" – 3/4"       | PRREC32           | 0.5            | PRREC32SA          |
| 1-1/4" – 3/4"   | PRREC42           | 1.0            | PRREC42SA          |
| 1-1/4" – 1"     | PRREC43           | 0.8            | PRREC43SA          |
| 1-1/2" – 3/4"   | PRREC52           | 1.4            | PRREC52SA          |
| 1-1/2" – 1"     | PRREC53           | 1.2            | PRREC53SA          |
| 1-1/2" – 1-1/4" | PRREC54           | 1.3            | PRREC54SA          |
| 2" – 3/4"       | PRREC602          | 1.5            | PRREC602SA         |
| 2" – 1"         | PRREC603          | 2.3            | PRREC603SA         |
| 2" – 1-1/4"     | PRREC604          | 2.6            | PRREC604SA         |
| 2" – 1-1/2"     | PRREC605          | 2.8            | PRREC605SA         |
| 2-1/2" – 1-1/2" | PRREC75           | 3.2            | –                  |
| 3" – 2"         | PRREC86           | 3.7            | PRREC86SA          |
| 3-1/2" – 2-1/2" | PRREC97           | 4.6            | –                  |
| 4" – 3"         | PRREC108          | 5.9            | –                  |
| 5" – 4"         | PRREC01210        | 7.4            | –                  |

### Split Couplings Specifications

#### APPLICATION

PLASTI-BOND REDH<sub>2</sub>O<sub>T</sub> split couplings are used to connect two pieces of conduit where the conduit can't be turned because of limited clearance between runs or a wall or other obstruction.

#### FEATURES

- 40 mil gray PVC exterior coating
- 2 mil red urethane interior coating
- 12 trade sizes from 1/2" through 6".
- Sealing sleeves on all conduit openings

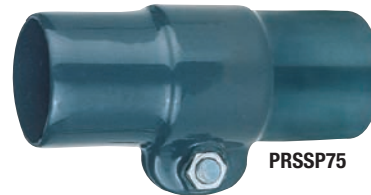

PRSSP75

### SPLIT COUPLINGS

| Pipe Size | FERROUS Catalog # | Nominal Weight |
|-----------|-------------------|----------------|
| 1/2"      | PRSSP50           | 0.2            |
| 3/4"      | PRSSP75           | 0.3            |
| 1"        | PRSSP100          | 0.4            |
| 1-1/4"    | PRSSP125          | 0.6            |
| 1-1/2"    | PRSSP150          | 0.7            |
| 2"        | PRSSP200          | 1.0            |
| 2-1/2"    | PRSSP250          | 2.3            |
| 3"        | PRSSP300          | 3.0            |
| 3-1/2"    | PRSSP350          | 3.8            |
| 4"        | PRSSP400          | 4.1            |
| 5"        | PRSSP500          | 6.0            |
| 6"        | PRSSP600          | 8.6            |

#### APPROVAL STAMP

(See online product submittal guide at [www.plastibond.com](http://www.plastibond.com))

# PLASTI-BOND REDH<sub>2</sub>O<sub>T</sub> PLUGS AND BUSHINGS

## PLUGS AND BUSHINGS

### Bushings and Plugs Technical Data

#### RE = Reducers

RE style reducers reduce conduit hubs to a smaller size. They are provided with an integral bushing to prevent conductor damage and full, clean cut threads for ease of assembly. **All RE reducers are coated inside and out with red polyurethane for corrosion protection.**

#### REDUCING BUSHINGS

| Pipe Size       | FERROUS Catalog # | Nominal Weight | Aluminum Catalog # |
|-----------------|-------------------|----------------|--------------------|
| 3/4" - 1/2"     | PRRE21            | 0.2            | PRRE21SA           |
| 1" - 1/2"       | PRRE31            | 0.7            | PRRE31SA           |
| 1" - 3/4"       | PRRE32            | 0.5            | PRRE32SA           |
| 1-1/4" - 1/2"   | PRRE41            | 0.8            | PRRE41SA           |
| 1-1/4" - 3/4"   | PRRE42            | 0.8            | PRRE42SA           |
| 1-1/4" - 1"     | PRRE43            | 0.8            | PRRE43SA           |
| 1-1/2" - 1/2"   | PRRE51            | 0.9            | PRRE51SA           |
| 1-1/2" - 3/4"   | PRRE52            | 0.9            | PRRE52SA           |
| 1-1/2" - 1"     | PRRE53            | 0.9            | PRRE53SA           |
| 1 1/2" - 1-1/4" | PRRE54            | 0.9            | PRRE54SA           |
| 2" - 1/2"       | PRRE61            | 1.1            | PRRE61SA           |
| 2" - 3/4"       | PRRE62            | 1.1            | PRRE62SA           |
| 2" - 1"         | PRRE63            | 1.2            | PRRE63SA           |
| 2" - 1-1/4"     | PRRE64            | 1.3            | PRRE64SA           |
| 2" - 1-1/2"     | PRRE65            | 1.6            | PRRE65SA           |
| 2-1/2" - 1"     | PRRE73            | 1.6            | PRRE73SA           |
| 2 1/2" - 1-1/4" | PRRE74            | 1.6            | PRRE74SA           |
| 2-1/2" - 1-1/2" | PRRE75            | 1.6            | PRRE75SA           |
| 2-1/2" - 2"     | PRRE76            | 1.7            | PRRE76SA           |
| 3" - 1"         | PRRE83            | 1.7            | PRRE83SA           |
| 3" - 1-1/4"     | PRRE84            | 2.3            | PRRE84SA           |
| 3" - 1-1/2"     | PRRE85            | 2.4            | PRRE85SA           |
| 3" - 2"         | PRRE86            | 2.5            | PRRE86SA           |
| 3" - 2-1/2"     | PRRE87            | 4.0            | PRRE87SA           |
| 3-1/2" - 2"     | PRRE96            | 4.6            | PRRE96SA           |
| 3-1/2" - 2-1/2" | PRRE97            | 4.7            | PRRE97SA           |
| 3-1/2" - 3"     | PRRE98            | 4.8            | PRRE98SA           |
| 4" - 2"         | PRRE106           | 5.0            | PRRE106SA          |
| 4" - 2-1/2"     | PRRE107           | 5.2            | PRRE107SA          |
| 4" - 3"         | PRRE108           | 6.0            | PRRE108SA          |
| 4" - 3-1/2"     | PRRE109           | 6.1            | PRRE109SA          |
| 5" - 4"         | PRRE01210         | 7.4            | PRRE01210SA        |
| 6" - 5"         | PRRE01412         | 8.0            | PRRE01412SA        |

#### GLL = Grounding Bushings

GLL style PVC coated threaded grounding bushings have an aluminum lug for copper or aluminum grounding conductors.

#### GROUNDING BUSHING

| Pipe Size | FERROUS Catalog # | Nominal Weight |
|-----------|-------------------|----------------|
| 1/2"      | PBGLL1            | 0.1            |
| 3/4"      | PBGLL2            | 0.1            |
| 1"        | PBGLL3            | 0.1            |
| 1-1/4"    | PBGLL4            | 0.2            |
| 1-1/2"    | PBGLL5            | 0.2            |
| 2"        | PBGLL6            | 0.3            |
| 2-1/2"    | PBGLL7            | 0.5            |
| 3"        | PBGLL8            | 0.7            |
| 3-1/2"    | PBGLL9            | 1.0            |
| 4"        | PBGLL10           | 1.1            |

#### PLG = Plugs

PLG style plugs are used to close unused conduit hubs. They are available with either recessed square drive sockets or raised square drive heads. **All PLG plugs are completely coated with red polyurethane for corrosion protection.**

#### SQUARE HEAD PLUGS

| Pipe Size | FERROUS Catalog # | Nominal Weight |
|-----------|-------------------|----------------|
| 1/2"      | PRPLG15           | 0.5            |
| 3/4"      | PRPLG25           | 0.6            |
| 1"        | PRPLG35           | 0.2            |
| 1-1/4"    | PRPLG45           | 0.3            |
| 1-1/2"    | PRPLG55           | 0.3            |
| 2"        | PRPLG65           | 0.4            |
| 2-1/2"    | PRPLG75           | 0.4            |
| 3"        | PRPLG85           | 0.5            |
| 3-1/2"    | PRPLG95           | 0.5            |
| 4"        | PRPLG105          | 0.6            |

#### RECESSED PLUGS

| Pipe Size | FERROUS Catalog # | Nominal Weight |
|-----------|-------------------|----------------|
| 1/2"      | PRPLG1            | 0.2            |
| 3/4"      | PRPLG2            | 0.2            |
| 1"        | PRPLG3            | 0.3            |
| 1-1/4"    | PRPLG4            | 0.3            |
| 1-1/2"    | PRPLG5            | 0.3            |
| 2"        | PRPLG6            | 0.3            |
| 2-1/2"    | PRPLG7            | 0.3            |
| 3"        | PRPLG8            | 0.4            |
| 3-1/2"    | PRPLG9            | 0.4            |
| 4"        | PRPLG10           | 0.5            |

#### APPROVAL STAMP

(See online product submittal guide at [www.plastibond.com](http://www.plastibond.com))



# PLASTI-BOND REDH<sub>2</sub>O<sub>T</sub> SUPPORT PRODUCTS

## PLASTI-BOND REDH<sub>2</sub>O<sub>T</sub> COATED PIPE STRAPS, CLAMP BACK SPACERS, AND THREAD RODS

### Pipe Straps and Clamp Back Spacers Specifications

#### APPLICATION

PLASTI-BOND PVC coated pipe straps are used to securely mount conduit to a wall or other structure for support. They are available in two styles: a one-hole malleable iron strap or a two-hole stamped steel strap. Mounting hardware not provided.

PLASTI-BOND PVC coated clamp back spacers are used with malleable or stamped pipe straps to provide a mounting stand-off for a conduit from a wall or other structure.



#### FEATURES

- 20 mil gray PVC exterior coating
- 10 trade sizes from 1/2" through 4".

#### CONDUIT PIPE STRAP 1 HOLE SETS

| Pipe Size | FERROUS Catalog # | Nominal Wt. For 100 |
|-----------|-------------------|---------------------|
| 1/2"      | PBPS11M           | 11                  |
| 3/4"      | PBPS22M           | 14                  |
| 1"        | PBPS33M           | 12                  |
| 1-1/4"    | PBPS44M           | 25                  |
| 1-1/2"    | PBPS55M           | 36                  |
| 2"        | PBPS66M           | 71                  |
| 2-1/2"    | PBPS77M           | 111                 |
| 3"        | PBPS88M           | 134                 |
| 3-1/2"    | PBPS99M           | 166                 |
| 4"        | PBPS100M          | 256                 |

#### CONDUIT PIPE STRAP 2 HOLE

| Pipe Size | FERROUS Catalog # | Nominal Wt. For 100 |
|-----------|-------------------|---------------------|
| 1/2"      | PBPS11S-2         | 2.0                 |
| 3/4"      | PBPS22S-2         | 3.0                 |
| 1"        | PBPS33S-2         | 4.0                 |
| 1-1/4"    | PBPS44S-2         | 4.5                 |
| 1-1/2"    | PBPS55S-2         | 5.0                 |
| 2"        | PBPS66S-2         | 10.0                |
| 2-1/2"    | PBPS77S-2         | 13.0                |
| 3"        | PBPS88S-2         | 17.0                |
| 3-1/2"    | PBPS99S-2         | 20.0                |
| 4"        | PBPS100S-2        | 25.0                |

#### CONDUIT CLAMP BACK SPACER

| Pipe Size | FERROUS Catalog # | Nominal Wt. Each |
|-----------|-------------------|------------------|
| 1/2"      | PBCLB-M50         | 0.1              |
| 3/4"      | PBCLB-M75         | 0.1              |
| 1"        | PBCLB-M100        | 0.1              |
| 1-1/4"    | PBCLB-M125        | 0.2              |
| 1-1/2"    | PBCLB-M150        | 0.2              |
| 2"        | PBCLB-M200        | 0.3              |
| 2-1/2"    | PBCLB-M250        | 1.0              |
| 3"        | PBCLB-M300        | 1.7              |
| 4"        | PBCLB-M400        | 2.0              |

### Conduit Clamp Hangers Specifications

#### APPLICATION

PLASTI-BOND PVC coated conduit clamp hangers are used with threaded rod to securely suspend conduit runs supported from above. They are provided with stainless steel hardware.

#### FEATURES

- 20 mil gray PVC exterior coating
- 10 trade sizes from 1/2" through 4".

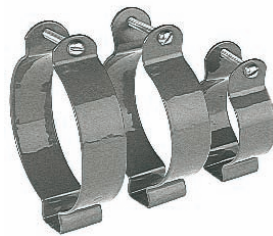

PB6HB Style

#### CONDUIT HANGER

| Pipe Size | Catalog # | Nominal Weight |
|-----------|-----------|----------------|
| 1/2"      | PB6H0B    | 0.1            |
| 3/4"      | PB6H1B    | 0.1            |
| 1"        | PB6H2B    | 0.1            |
| 1-1/4"    | PB6H3B    | 0.1            |
| 1-1/2"    | PB6H4B    | 0.2            |
| 2"        | PB6H5B    | 0.3            |
| 2-1/2"    | PB6H6B    | 0.4            |
| 3"        | PB6H7B    | 0.5            |
| 3-1/2"    | PB6H8B    | 0.6            |
| 4"        | PB6H9B    | 0.7            |

### All Thread Rod Specifications

#### APPLICATION

PLASTI-BOND PVC coated all thread rod is used with coated conduit hangers and coated strut to securely suspend conduit runs supported from above. It is provided in 3/8" and 1/2" sizes and three standard lengths, 3', 6' and 10'.

#### FEATURES

- 20 mil gray PVC exterior coating
- 2 trade sizes and 3 standard lengths



PBH193

#### THREAD RODS

| Size       | Catalog #     |
|------------|---------------|
| 3/8" X 3'  | PBH193-3/8X3  |
| 3/8" X 6'  | PBH193-3/8X6  |
| 3/8" X 10' | PBH193-3/8X10 |
| 1/2" X 3'  | PBH193-1/2X3  |
| 1/2" X 6'  | PBH193-1/2X6  |
| 1/2" X 10' | PBH193-1/2X10 |

# PLASTI-BOND REDH<sub>2</sub>O<sup>T</sup> SUPPORT PRODUCTS

## PLASTI-BOND REDH<sub>2</sub>O<sup>T</sup> COATED PIPE STRAPS AND STEEL STRUTS

### Coated Pipe Straps

#### APPLICATION

PLASTI-BOND PVC coated pipe straps are used with coated strut to support conduit installations in a variety of configurations. PBC105 style straps may be used in either vertical or horizontal positions to support conduit. Straps provided with stainless steel hardware. Conduit spacing may be as close together as allowed by the couplings. PBC149 style straps may be used with hanger rods or other means of support to securely fasten conduit runs.

#### FEATURES

- 20 mil gray PVC exterior coating
- Available in 11 trade sizes.

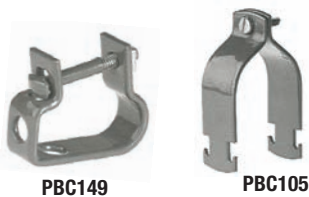

#### PVC COATED PIPE STRAPS

| Size   | FERROUS Catalog # | Gauge Metal | Weight For 100 pcs | Standard Pack |
|--------|-------------------|-------------|--------------------|---------------|
| 1/2"   | PBC149-1/2        |             | 18                 | 25            |
| 3/4"   | PBC149-3/4        |             | 21                 | 25            |
| 1"     | PBC149-1          |             | 22                 | 25            |
| 1-1/4" | PBC149-1-1/4      |             | 25                 | 25            |
| 1-1/2" | PBC149-1-1/2      |             | 27                 | 25            |
| 2"     | PBC149-2          |             | 29                 | 25            |
| 2-1/2" | PBC149-2-1/2      |             | 64                 | 25            |
| 3"     | PBC149-3          |             | 72                 | 25            |
| 3-1/2" | PBC149-3-1/2      |             | 84                 | 25            |
| 4"     | PBC149-4          |             | 138                | 10            |
| 5"     | PBC149-5          |             | 162                | 10            |

#### PVC COATED PIPE STRAPS

| Size   | FERROUS Catalog # | Gauge Metal | Weight For 100 pcs | Standard Pack |
|--------|-------------------|-------------|--------------------|---------------|
| 1/2"   | PBC105-1/2        | 14          | 13.0               | 100           |
| 3/4"   | PBC105-3/4        | 14          | 15.0               | 100           |
| 1"     | PBC105-1          | 14          | 17.0               | 100           |
| 1-1/4" | PBC105-1-1/4      | 12          | 19.5               | 100           |
| 1-1/2" | PBC105-1-1/2      | 12          | 28.0               | 100           |
| 2"     | PBC105-2          | 12          | 31.0               | 50            |
| 2-1/2" | PBC105-1-1/2      | 12          | 36.0               | 50            |
| 3"     | PBC105-3          | 12          | 42.0               | 50            |
| 3-1/2" | PBC105-3-1/2      | 11          | 56.0               | 25            |
| 4"     | PBC105-4          | 11          | 64.0               | 25            |
| 5"     | PBC105-5          | 10          | 76.0               | 25            |

### PVC Coated Ferrous Strut Specifications

#### APPLICATION

PLASTI-BOND PVC coated strut is a versatile system of structural elements that can be used to build supports for a variety of applications. When combined with coated conduit hangers and other accessories, coated strut is a versatile and economical way to provide reliable support for conduit runs and other electrical and mechanical installations.

#### FEATURES

- 20 mil gray PVC exterior coating
- 2 trade sizes and 3 standard styles

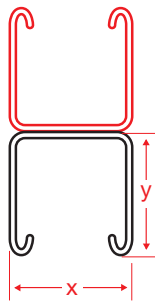
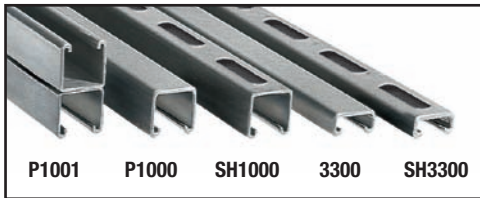

#### PVC COATED STRUT

| Style                | FERROUS Catalog # | Nominal Wt. Per 100 ft. | X    | Y    | Strut Thickness |
|----------------------|-------------------|-------------------------|------|------|-----------------|
| Channel              | PBP1000-10        | 200.0                   | 1.67 | 1.67 | 12 ga.          |
| Channel Slotted      | PBSH1000-10       | 185.0                   | 1.67 | 1.67 | 12 ga.          |
| Channel Back to Back | PBP1001-10        | 380.0                   | 1.67 | 3.29 | 12 ga.          |
| Channel Shallow      | PBP3300-10        | 135.0                   | 1.67 | 0.92 | 12 ga.          |
| Channel Slotted      | PBSH3300-10       | 130.0                   | 1.67 | 0.92 | 12 ga.          |

#### PVC COATED STRUT CUT-TO-LENGTH

| FERROUS Catalog #                  | Description   | X    | Y    | Length In Ft. | Strut Thickness |
|------------------------------------|---------------|------|------|---------------|-----------------|
| PBP1000-1                          | 1-5/8 CHANNEL | 1.67 | 1.67 | 1             | 12 ga.          |
| PBP1000-1-1/2                      | 1-5/8 CHANNEL | 1.67 | 1.67 | 1-1/2         | 12 ga.          |
| PBP1000-2                          | 1-5/8 CHANNEL | 1.67 | 1.67 | 2             | 12 ga.          |
| PBP1000-2-1/2                      | 1-5/8 CHANNEL | 1.67 | 1.67 | 2-1/2         | 12 ga.          |
| PBP1000-3                          | 1-5/8 CHANNEL | 1.67 | 1.67 | 3             | 12 ga.          |
| <b>CHANNELS WITH SLOTTED HOLES</b> |               |      |      |               |                 |
| PBSH1000-1                         | 1-5/8 CHANNEL | 1.67 | 0.92 | 1             | 12 ga.          |
| PBSH1000-1-1/2                     | 1-5/8 CHANNEL | 1.67 | 0.92 | 1-1/2         | 12 ga.          |
| PBSH1000-2                         | 1-5/8 CHANNEL | 1.67 | 0.92 | 2             | 12 ga.          |
| PBSH1000-2-1/2                     | 1-5/8 CHANNEL | 1.67 | 0.92 | 2-1/2         | 12 ga.          |
| PBSH1000-3                         | 1-5/8 CHANNEL | 1.67 | 0.92 | 3             | 12 ga.          |

### PVC Coated Strut Nut Specifications

#### APPLICATION

PLASTI-BOND PVC coated strut nuts are used to assemble strut components and to secure coated all thread rod in a section of strut. These are available with or without a spring to aid in placement and assembly.

#### FEATURES

- 20 mil gray PVC exterior coating
- 10 trade sizes from 1/2" through 4".



#### COATED STRUT NUT

| Pipe Size | FERROUS Catalog # |
|-----------|-------------------|
| 3/8"      | PBB910-3/8        |
| 1/2"      | PBB910-1/2        |
| 3/8"      | PBB911-3/8        |
| 1/2"      | PBB911-1/2        |
| 3/8"      | PBB914-3/8        |
| 1/2"      | PBB914-1/2        |

# PLASTI-BOND REDH<sub>2</sub>O<sub>T</sub> SUPPORT PRODUCTS

## PLASTI-BOND REDH<sub>2</sub>O<sub>T</sub> COATED BEAM CLAMPS AND U-BOLTS

### Beam Clamps and U-Bolts Specifications

#### APPLICATION

PLASTI-BOND PVC coated beam clamps are used to securely support conduit runs by attaching them to beams, angles, trusses and other structural members. They are available in four different styles:

**Right Angle** – to attach the conduit run at a 90° angle to a beam or structural member.

**Parallel** – to attach the conduit run parallel to a beam or structural member.

**Edge** – to attach the conduit run at a 90° angle to a thin beam or structural member.

**Hanger Rod Beam Clamp** – to attach a single all thread rod to a beam or structural member.

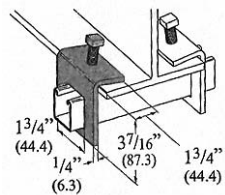

#### STRUT WINDOW BEAM CLAMPS

| FERROUS Catalog # | Nominal Weight |
|-------------------|----------------|
| PBB441-22         | 0.9            |
| PBB441-22A        | 0.9            |

#### FEATURES

- 40 mil gray PVC exterior coating on right angle clamps.
- 20 mil gray PVC exterior coating on parallel and edge clamps.
- Right angle clamps supplied with plastic encapsulated screws.
- All clamps specifically sized to fit PVC coated conduit.
- Right angle and parallel clamps available in 10 trade sizes 1/2" through 4".
- Edge clamps available in 3 trade sizes 1/2" through 1".
- Hanger rod beam clamps available with 5 different jaw openings 15/16" through 2 1/8"

#### COATED NUTS

| FERROUS CATALOG # | Description                      |
|-------------------|----------------------------------|
| PBNUIT-KIT-1      | 5/16 ENC NUTS-RA,UBLT 1/2 -1 1/4 |
| PBNUIT-KIT-2      | 3/8 ENC NUTS - RA,UBLT 1 1/2-6   |



Parallel Beam Clamp



Edge Beam Clamp



Right Angle Beam Clamp

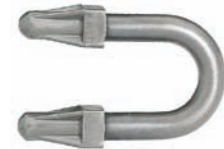

U bolt

#### PARALLEL CONDUIT CLAMP

| Pipe Size | FERROUS Catalog # | Nominal Weight |
|-----------|-------------------|----------------|
| 1/2"      | PBPAR-1/2         | 46.8           |
| 3/4"      | PBPAR-3/4         | 63.0           |
| 1"        | PBPAR-1           | 67.0           |
| 1-1/4"    | PBPAR-1-1/4       | 100.0          |
| 1-1/2"    | PBPAR-1-1/2       | 130.0          |
| 2"        | PBPAR-2           | 158.0          |
| 2-1/2"    | PBPAR-2-1/2       | 175.0          |
| 3"        | PBPAR-3           | 200.0          |
| 3-1/2"    | PBPAR-3-1/2       | 250.0          |
| 4"        | PBPAR-4           | 275.0          |

#### EDGE STYLE CONDUIT CLAMP

| Pipe Size | FERROUS Catalog # | Nominal Weight |
|-----------|-------------------|----------------|
| 1/2"      | PBEDGE-1/2        | 74.0           |
| 3/4"      | PBEDGE-3/4        | 90.0           |
| 1"        | PBEDGE-1          | 100.0          |

#### RIGHT ANGLE CONDUIT CLAMP

| Pipe Size | FERROUS Catalog # | Nominal Weight |
|-----------|-------------------|----------------|
| 1/2"      | PBRA-1/2          | 49.0           |
| 3/4"      | PBRA-3/4          | 53.0           |
| 1"        | PBRA-1            | 61.0           |
| 1-1/4"    | PBRA-1-1/4        | 65.0           |
| 1-1/2"    | PBRA-1-1/2        | 92.0           |
| 2"        | PBRA-2            | 100.0          |
| 2-1/2"    | PBRA-2-1/2        | 125.0          |
| 3"        | PBRA-3            | 150.0          |
| 3-1/2"    | PBRA-3-1/2        | 175.0          |
| 4"        | PBRA-4            | 198.0          |

#### CONDUIT U-BOLT

| Pipe Size | FERROUS Catalog # | Nominal Weight |
|-----------|-------------------|----------------|
| 1/2"      | PBU-BOLT-1/2      | 17.0           |
| 3/4"      | PBU-BOLT-3/4      | 18.0           |
| 1"        | PBU-BOLT-1        | 20.0           |
| 1-1/4"    | PBU-BOLT-1-1/4    | 20.0           |
| 1-1/2"    | PBU-BOLT-1-1/2    | 31.0           |
| 2"        | PBU-BOLT-2        | 34.0           |
| 2-1/2"    | PBU-BOLT-2-1/2    | 39.0           |
| 3"        | PBU-BOLT-3        | 44.0           |
| 3-1/2"    | PBU-BOLT-3-1/2    | 45.0           |
| 4"        | PBU-BOLT-4        | 49.0           |
| 5"        | PBU-BOLT-5        | 100.0          |
| 6"        | PBU-BOLT-6        | 130.0          |

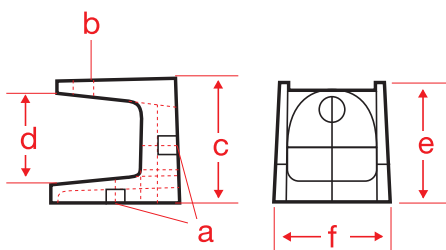

#### BEAM CLAMPS

| Pipe Size | FERROUS Catalog # | A          | B          | C     | D     | E      | F      | Nominal Weight | Maximum Load |
|-----------|-------------------|------------|------------|-------|-------|--------|--------|----------------|--------------|
| 1"        | PB500             | 1/4-20     | 5/16-1-1/8 | 1-5/8 | 7/8   | 1-1/2  | 1-1/4  | 25             | 500          |
| 1-1/4"    | PB501             | 5/16-1-1/8 | 3/8-16     | 1-3/4 | 1     | 1-5/8  | 1-5/8  | 50             | 800          |
| 1-1/2"    | PB502             | 3/8-16     | 1/2-13     | 2-1/8 | 1-1/4 | 2-1/16 | 2-1/16 | 90             | 2000         |
| 2"        | PB503             | 1/2-13     | 1/2-13     | 2-5/8 | 1-1/2 | 2-1/4  | 2-1/2  | 195            | 2000         |
| 2-1/2"    | PB508             | 1/2-13     | 1/2-13     | 3-3/8 | 2-1/4 | 2-1/2  | 2-5/8  | 25             | 4000         |

# PLASTI-BOND REDH<sub>2</sub>OT SUPPORT PRODUCTS

## PLASTI-BOND REDH<sub>2</sub>OT COATED BEAM CLAMPS AND U-BOLTS



With the Plasti-Bond **SPIN-IT**, Plasti-Bond REDH<sub>2</sub>OT can be tightened much faster than with conventional tools. Because **SPIN-IT** never touches the coating, damage to the conduit is eliminated. **SPIN-IT** is available in popular sizes for 3/4" through 2" drive conduit. Use 1/2" drive impact wrench or a standard ratchet wrench for 3/4" and 1" conduit, use 3/4" drive for sizes 1-1/4" through 2".



**PLASTI-SOCKET** is a fiber-glass encapsulated 3/8" drive socket for use with the square fiberglass encapsulated U bolt and beam clamp nuts used in the Plasti-Bond RED-H<sub>2</sub>OT conduit support system. They fit a standard 3/8" drive ratchet and speed up installation while avoiding coating damage from metal sockets, pliers or wrenches.

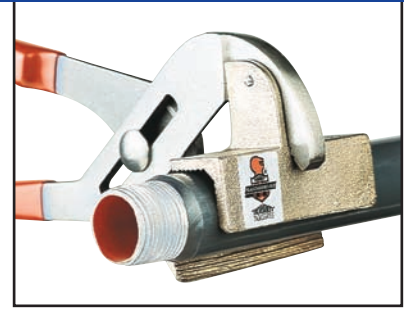

**Z-WRENCH** features extra wide jaws which spread the clamping force, enabling the tool to grip without marring the surface of the conduit. The "V" shaped upper jaw allows **Z-WRENCH** to accommodate a wide range of conduit sizes. Shallow grooves in the upper and lower jaws provide an excellent grip.

### JAWS 3

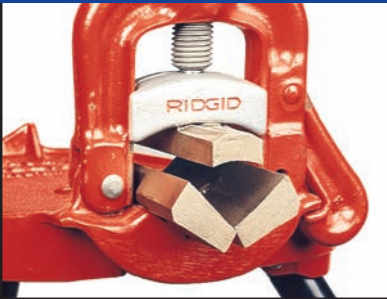

**JAWS 3** are a set of aluminum-nickel-bronze vise jaws designed to replace the regular jaws in a RIGID #23 or #40-A pipe vise. **JAWS 3** are designed for use with Plasti-Bond REDH<sub>2</sub>OT Coated Conduit. They completely protect the exterior coating from damage caused by the vise jaws when cutting or threading. One set of **JAWS 3** handles Plasti-Bond REDH<sub>2</sub>OT Coated Conduit sizes from 1/2" through 1-1/2". Model #23 fits the RIGID #23 pipe vise. Model #40-A fits the RIGID #40-A tripod pipe vise.

### HALF SHELL CLAMPS



**HALF SHELL CLAMPS** are designed to cover a large surface area when clamping conduit, especially in a chain vise. This allows for a strong grip without damaging the exterior coating. **HALF SHELL CLAMPS** are available for clamping 2" through 6" conduit.

### HICKEY



The **PLASTI-BOND Hickey** is a special bending tool with a 40 mil PVC coating which reduces the possibility of damage during conduit bending.

*See the following page for Installation Tools catalog numbers*

## PLASTI-BOND TOUCH UP COMPOUNDS

### APPLICATION

PLASTI-BOND REDH<sub>2</sub>OT Touchup Compounds are available to repair minor damage to the interior urethane or exterior PVC factory coatings. The exterior PVC touchup compound is gray and available in a 12 oz. aerosol can, and a pint can with brush-top applicator.

The approved thread compound touchup compound is available in a pint can with a brush-top applicator.

See the installation section of the buyers' guide for more information on using the PLASTI-BOND touchup compounds.

### PLASTI-BOND TOUCH UP COMPOUNDS

| Catalog Number    | DESCRIPTION                                 | Size   |
|-------------------|---------------------------------------------|--------|
| PBTOUCHUP-SPRAY   | Exterior Spray Type (Gray)                  | 12 oz. |
| PBTOUCHUP-GRAY-PT | Exterior Non-Spray with Brush-Top (Gray)    | 1 pt.  |
| PBTHREAD-COMPOUND | Approved Conductive Compound-Brush-Top Pint | 1 pt.  |





# Installation Guide

Plasti-Bond REDH<sub>2</sub>OT is totally encapsulated, providing the best available exterior and interior protection against corrosion.

- A 40 mil PVC exterior coating is permanently fused to rigid metal conduit.
- A tough, flexible urethane coating is applied to the interior of the conduit by an exclusive process.
- Using a unique, proprietary system, threads are protected from corrosion by hot galvanizing after PVC coating of the conduit and before application of a clear polyurethane topcoat.

Proper installation is essential to ensure the highest possible performance and provide maximum life for a conduit system. You're probably an expert at installing non-coated rigid metal conduit. We'd like to give you a few tips to assure the best possible PVC coated conduit installation. With the exceptions of a few precautions necessary to protect the coatings, coated rigid metal conduit installation procedures are the same as those for installing non-coated rigid conduit.

Installing Plasti-Bond REDH<sub>2</sub>OT involves five basic steps:

- 1. Clamping**
- 2. Cutting**
- 3. Threading**
- 4. Bending**
- 5. Assembly**

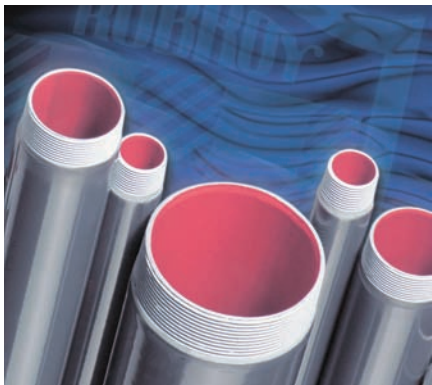

*Proper installation is essential to insure the highest possible performance and provide maximum life for a conduit system.*

### INSTALLATION TOOLS

| Catalog #          | Description                    |
|--------------------|--------------------------------|
| SPSPIN-IT-3/4      | 3/4 SPIN-IT                    |
| SPSPIN-IT-1        | 1 SPIN-IT                      |
| SPSPIN-IT-1-1/4    | 1-1/4 SPIN-IT                  |
| SPSPIN-IT-1-1/2    | 1-1/2 SPIN-IT                  |
| SPSPIN-IT-2        | 2 SPIN-IT                      |
| PBHICKEY           | 1/2" & 3/4" CONDUIT BENDER     |
| PSPLASTISOCKET-3/8 | 3/8 PLASTISOCKET               |
| SPJPZ1             | 1/2 - 1-1/4 Z-WRENCH           |
| SPJPZ2             | 1-1/2 - 2-1/2 Z-WRENCH         |
| JWJAWS3-#23        | JAWS #23 PIPE VISE             |
| JWJAWS3-#40-A      | JAWS #40-A TRIPOD PIPE VISE    |
| JWHLF-SHL-CLP2     | 2 HALF-SHELL CONDUIT CLAMP     |
| JWHLF-SHL-CLP2-1/2 | 2-1/2 HALF-SHELL CONDUIT CLAMP |
| JWHLF-SHL-CLP3     | 3 HALF-SHELL CONDUIT CLAMP     |
| JWHLF-SHL-CLP3-1/2 | 3-1/2 HALF-SHELL CONDUIT CLAMP |
| JWHLF-SHL-CLP4     | 4 HALF-SHELL CONDUIT CLAMP     |
| JWHLF-SHL-CLP5     | 5 HALF-SHELL CONDUIT CLAMP     |
| JWHLF-SHL-CLP6     | 6 HALF-SHELL CONDUIT CLAMP     |



# CLAMPING

## PLASTI-BOND REDH<sub>2</sub>OT INSTALLATION

A number of practical ways are recommended for clamping Plasti-Bond REDH<sub>2</sub>OT.

If a power drive unit that spins the conduit is used, the chuck should be equipped with inserts designed specifically for PVC coated conduit. These inserts are available through a local threading equipment distributor.

When using a pipe vise it is recommended that the jaw assembly be replaced with Plasti-Bond Jaws 3 vise adapters.

These adapters spread the clamping force over a larger area, which helps prevent spinning of the pipe during

cutting and threading operations.

If Jaws 3 adapters are not used, wrap the area of the conduit to be clamped with emery cloth coarse side down. This will increase the friction created by the vise jaws and help prevent spinning of the pipe, thereby reducing potential damage to the coating.

We have developed half shell clamps to protect a large surface area when conduit is clamped in a chain vise. The aluminum nickel bronze clamps allow for a strong grip without damaging the exterior coating of the coated conduit. 1/2 shell clamps are available in sizes 2 through 6 inches.

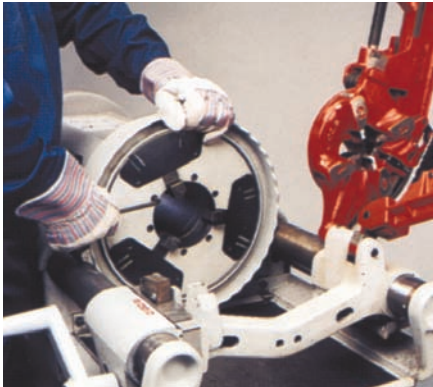

*On a power drive unit inserts should be used that are designed for PVC coated conduit.*

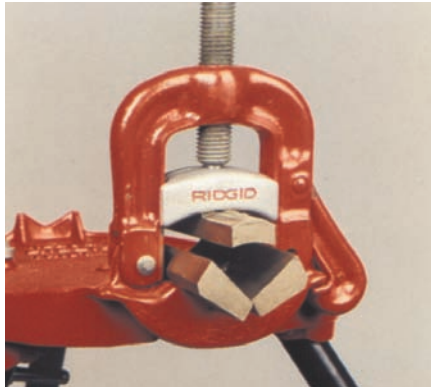

*When using a pipe vise it is recommended that the jaw assembly be replaced with Jaws 3 vise adapters.*



*When a chain vise is used special care must be taken to prevent damage to the exterior coating.*

# CUTTING

## PLASTI-BOND REDH<sub>2</sub>OT INSTALLATION

We recommend using a roller cutter to cut coated conduit. In addition to producing a square cut end, the roller cutter will remove approximately 1/4" of the PVC coating, aiding in conduit threading. Conventional manual or power saws

may also be used to cut conduit. Use a reamer to remove any rough edges from the conduit interior caused by the cutting operation. This ensures that the wire pulled through the conduit will not be damaged.

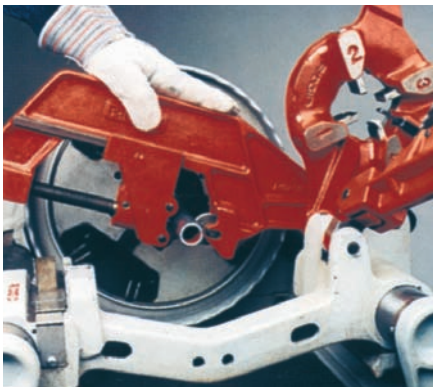

*We recommend that Plasti-Bond REDH<sub>2</sub>OT conduit be cut with a roller cutter.*



*The PVC coating may need to be pencil cut in order that the die teeth may engage the conduit.*



*Use a reamer to remove rough edges.*

# THREADING

## PLASTI-BOND REDH<sub>2</sub>OT INSTALLATION

Plasti-Bond REDH<sub>2</sub>OT can be threaded with any standard threading tool. Larger model power threaders with open die heads require no modification beyond optional grip inserts for PVC coated conduit.

If a threader with a tight-fitting die head is to be used, like many hand-held models, it is necessary to machine out the interior diameter of the stationary guide approximately 12/100ths of an inch to allow for clearance of the PVC coating. Prior to machining the pipe guide take note of the sequence in which the dies are removed; then replace dies in the proper sequence.

If conduit is to be threaded manually it must be pencil cut before threading to enable the die teeth on the threader to engage the conduit. In the same manner as sharpening a pencil with a knife, cut away 1/4" of the exterior coating from the end to be threaded. This allows the pipe guide to ride up and over the PVC coating enabling the removal of the coating and threading in one operation.

Before threading, by any method, a series of cuts should be made in the PVC coating along the longitudinal axis of the conduit. The thread protector attached to one end of the conduit can be used to gauge the length of the cuts. Make a slit up one side of the thread protector with a knife and remove it from the conduit. Push the thread protector over the cut end of the conduit to be threaded and place a mark on the PVC coating at the end of the protector. With a knife, cut around the circumference of the conduit at the mark, through the PVC coating, to the metal. This cut will indicate the starting point for the longitudinal cuts and it will give an even ending to the PVC coating removed during threading. The longitudinal cuts will allow the PVC coating to be removed in small pieces instead of long strips that can foul the die head causing the conduit to collapse.

Use a good quality thread cutting oil to flush away the metal and PVC chips. After threading use a degreasing spray to thoroughly clean the threads and the interior of the pipe. Use care not to contaminate the cutting oil with the degreasing spray. Degreasing is important in order to insure that the touch up compound will adhere to the unprotected steel. Bare steel is the most vulnerable area to corrosion in any conduit system, therefore, touch up compound must be used on all field cut threads and internal reams. These specially formulated interior and thread touch-up compounds are available in 1 pt cans. When an access fitting or coupling is attached to the newly threaded conduit a colored band (red for Plasti-Bond REDH<sub>2</sub>OT), will form at the end of the sleeve. This indicates proper installation procedures have been followed.

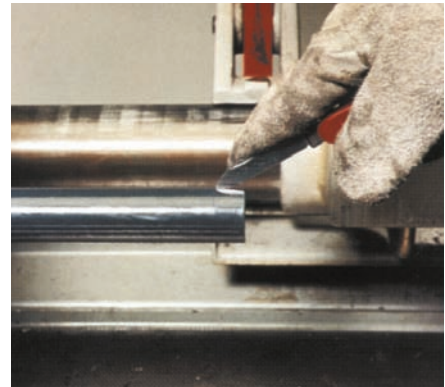

*A series of cuts should be made along the longitudinal axis of the conduit.*

- For safety, always use a fixed or locking-blade knife.



*After threading, use a degreasing spray to thoroughly clean the threads and interior of the pipe.*



*Plasti-Bond Thread Compound must be used on all field cut threads and internal reams.*

- Please note: when threading Plasti-Bond Aluminum conduit, always use new die heads, never use the same die head to thread PVC coated aluminum conduit and coated steel conduit.

# BENDING

## PLASTI-BOND REDH<sub>2</sub>OT INSTALLATION

We offer a complete line of standard, special and large radius elbows, ready for quick shipment. When field bending is necessary, there are a variety of bending tools from which to choose. Plasti-Bond REDH<sub>2</sub>OT can be bent with conventional types of bending equipment.

To accommodate the PVC coating when using a hand bender: always select the next larger size shoe.

Use a Plasti-Bond hickey to reduce the possibility of damage to the conduit coating when making sharp bends, saddles or offsets.

For optimum results use equipment specially designed for bending PVC coated conduit. When bending Plasti-Bond REDH<sub>2</sub>OT with powered equipment, use rubbing alcohol to clean the inside of the shoe and the area of the conduit to be bent.

Never use a lubricant on the shoe or conduit. Lubricants tend to allow the conduit to slip above the center-line of the shoe, resulting in flattening of the elbow.

Major manufacturers of bending equipment offer bending shoes for coated conduit that can be ordered for existing equipment. Acceptable results can be obtained by machining out existing shoes. Use shoes the same size as the conduit to be bent and remove approximately 6/100ths of an inch from the inside of the shoe.



*To accommodate the PVC coating when using a hand bender, always use the next larger size shoe. Use a Plasti-Bond coated hickey to reduce the possibility of damage to the conduit coating.*



### ***With Plasti-Bond, You'll Get ETL-Verified Performance Together with PVC UL Listed As The Primary Corrosion Protection For Your Conduit!***

Plasti-Bond REDH<sub>2</sub>OT gives you something very important ...PVC coated conduit that is UL Listed with PVC as the primary corrosion protection. Why is that important? Because PVC is what keeps your conduit safe from corrosive attack. ETL-Verified testing ensures continued performance.

### ***Specialty Services***

As experts in anti-corrosion coating technology, we have the ability to custom coat a variety of electrical and related products in addition to those listed in this Buyer's Guide. For additional details consult your Plasti-Bond sales rep or contact the factory direct at 903-843-5591.



# ASSEMBLY

## PLASTI-BOND REDH<sub>2</sub>OT INSTALLATION

Our engineers, working in conjunction with prominent manufacturers, have developed special tools to aid in installation of Plasti-Bond REDH<sub>2</sub>OT. Plasti-Bond touch up compound is used to repair nicks, cuts, and abrasions to the outer surface of coated conduit. Apply the exterior touch up compound liberally over damaged areas. Because this material will not adhere to bare metal, it is advisable to overlap existing PVC coating. Sometimes it may be necessary to apply several coats in order to obtain adequate coverage. Allow the first coat to dry completely before applying additional coats.

Another application for exterior touch up compound is for use as a sealant at access fitting openings. In wet locations apply the compound to the factory conduit threads at each joint before installation.

Exterior touch up compound is available in pints with a brush top applicator. It is also available in a 12 ounce aerosol can when cosmetic coverage is desired.

Plasti-Bond Z Wrenches are designed to replace standard adjustable pliers. Z wrenches feature extra wide jaws which spread the clamping force enabling the tools to grip securely without marring the surface of the conduit.

The v-shaped upper jaw allows the wrench to accommodate a wide range of conduit sizes. Shallow grooves in the upper and lower jaws provide an excellent grip. Z Wrenches are available in two sizes to fit 1/2" through 2 1/2" conduit.

With a Plasti-Bond spin-it, conduit can be tightened much faster than with a conventional tool and the spin-it never touches the coating. Labor and time are saved because no touch up is necessary for marks from wrenches or pliers. Spin-its are available in popular conduit sizes 3/4 through 2 inches. Use a 1/2" drive impact or ratchet wrench for 3/4" and 1" conduit and a 3/4" drive impact or ratchet wrench for sizes 1-1/4" through 2".

We have designed a special PVC hickey to reduce the possibility of damage during conduit bending. It is available to handle 1/2" and 3/4" conduit.



*Plasti-Bond Touch Up compound is available in pints, and in an aerosol spray.*

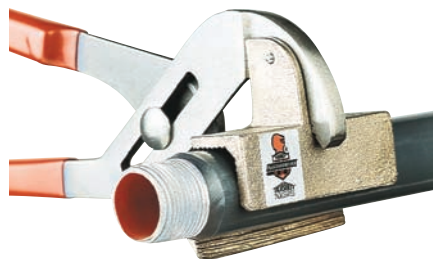

*Z Wrenches have extra wide jaws which spread the clamping force.*

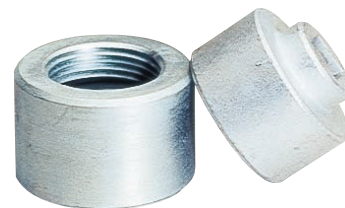

*Spin-It can tighten conduit much faster than conventional tools.*

# ASSEMBLY

## PLASTI-BOND REDH<sub>2</sub>OT INSTALLATION

Jaws 3 is a set of three aluminum nickel bronze vise jaws designed to replace the regular jaws in a pipe vise. Jaws 3 protects coated conduit from damage during cutting and threading. These replacement jaws spread the cutting force over a much larger area greatly reducing the possibility of the pipe spinning in the vise during cutting and threading operations. One set of jaws 3 handles 1/2 through 2-1/2" conduit.

When ordering Jaws 3 be sure to specify the vise model you are using.

Use the Plasti-Bond plastic socket and standard 3/8" ratchet to speed up u-bolt and beam clamp installation. The plastic socket prevents abrasion and cracking of encapsulated nuts, which may be caused by pliers or wrenches, and it assures a tight seal between the nut and the saddle. The 3/8" Plasti-sockets fits nuts for 1/2" through 2" clamps. The 5/8" Plasti-sockets fits nuts for 2-1/2" and larger sizes. Both Plasti-sockets fit a standard 3/8" drive ratchet wrench.

Here are some tips to remember when using conventional tools to install Plasti-Bond REDH<sub>2</sub>OT.

When a pipe wrench or adjustable pliers must be used, new tools with sharp teeth work best. New tools are less likely to slip and gouge the coating. The same holds true for pipe vises. New, sharp inserts should be installed if the existing ones show signs of wear. Strap wrenches are available from a number of sources and do an adequate job of tightening conduit and couplings without damaging the coatings. Several suppliers offer straps that have been specifically woven and treated to provide an extra strong grip on coated conduit.

Unique innovations included as part of Plasti-Bond REDH<sub>2</sub>OT coated conduit system add extra protection. The patented V-seal gasket system on Plasti-Bond REDH<sub>2</sub>OT Form 8 conduit sizes 1/2" through 2" effectively seals the fitting with a male-female interlocking groove. V-seal covers are easy to install because of the positive fit, eliminating side to side movement.

Our coated conduit and fittings feature an interior urethane coating (red for Plasti-Bond REDH<sub>2</sub>OT). This hard smooth coating allows for easier wire pulling and will not crack or chip. The interior coating needs no heat or special considerations when field bending.



*Jaws 3 was designed to protect Plasti-Bond REDH<sub>2</sub>OT conduit from damage by vise jaws during conduit bending.*



*Prevent damage to encapsulated nuts by using the Plasti-Socket.*



*We developed Half Shell Clamps to protect a large surface area when conduit is clamped*



# ASSEMBLY

## PLASTI-BOND REDH<sub>2</sub>OT INSTALLATION

Matching couplings are offered as a standard part of the system. The molded ribs protect the coating from cuts and abrasions caused by the teeth of wrenches and pliers. Since damage is minimized and the bare metal is never exposed, touch up operations are eliminated. Ribbed couplings are also easier to install. They can be tightened easily by hand and strap wrenches grip the ribs better.

Pressure sealing sleeves are present at all female openings. Here's an important tip to remember. Never cut the sleeves from Plasti-Bond fittings. These sleeves are necessary at all joints to seal out corrosion. However in some joints it is necessary to remove a portion of the sleeve. An example of this is the junction of a conduit, close nipple, and a union where both pressure sealing sleeves will not fit over the close nipple. In this case: cut away 1/2 of each sleeve and apply touch up compound to the threads.

Encapsulated nuts for U-bolts and specially formed saddles on right angle beam clamps are other unique features offered as part of the Plasti-Bond system. U-bolts are made to fit snugly on conduit, and each nut is encapsulated in plastic. A sleeve covers the U-bolt threads, sealing out corrosive elements.

Encapsulated screws are provided with all Form 8 conduit bodies. They prevent corrosive elements from attacking the stainless steel fastener used to attach the cover to the body, and help to seal out corrosive liquids from the screw opening. A nut driver or socket is recommended for installing the encapsulated screws.

- Buy Plasti-Bond PVC coated galvanized rigid conduit and fittings.
- Install them with the proper tools and follow proven procedures.
- Expect a superior, long lasting corrosion resistant system that pays for itself with lower maintenance costs and reduced down time.

Plasti-Bond REDH<sub>2</sub>OT... you can install it and forget it.



*The V Seal™ gasket system on form 8 condulets sizes 1/2" through 2" effectively seals the fitting with a male female interlocking groove.*



*Ribbed couplings are offered as a standard part of the Plasti-Bond REDH<sub>2</sub>OT conduit system.*



*Encapsulated screws are provided on all form 8 condulets.*

# TECHNICAL INFORMATION

## URETHANE INTERIOR COATING CHEMICAL RESISTANCE CHART

| SOLUTIONS                   | CONC. | TEMP. | RECOMMENDED EXPOSURE |        |           |
|-----------------------------|-------|-------|----------------------|--------|-----------|
|                             |       |       | FUMES                | SPLASH | IMMERSION |
| Acetic Acid                 | 10%   | 75° F | YES                  | YES    | NO        |
| Acid Copper Plating Sol.    | Any   | 75° F | YES                  | YES    | NO        |
| Alkaline Cleaners           | Any   | 75° F | YES                  | YES    | NO        |
| Aluminum Chloride           | Sat'd | 75° F | YES                  | YES    | NO        |
| Aluminum Sulfate            | Sat'd | 75° F | YES                  | YES    | NO        |
| Alums                       | Sat'd | 75° F | YES                  | YES    | NO        |
| Ammonium Chloride           | Sat'd | 75° F | YES                  | YES    | NO        |
| Ammonium Hydroxide          | 28%   | 75° F | YES                  | YES    | NO        |
| Ammonium Hydroxide          | 10%   | 75° F | YES                  | YES    | NO        |
| Ammonium Sulfate            | Sat'd | 75° F | YES                  | YES    | NO        |
| Ammonium Thiocyanate        | Sat'd | 75° F | YES                  | YES    | NO        |
| Amyl Alcohol                | Sat'd | 75° F | YES                  | YES    | YES       |
| Arsenic Acids               | Any   | 75° F | YES                  | YES    | NO        |
| Barium Sulfide              | Sat'd | 75° F | YES                  | YES    | NO        |
| Black Liquor                | Sat'd | 75° F | YES                  | YES    | NO        |
| Benzoic Acid                | Sat'd | 75° F | YES                  | YES    | NO        |
| Brass Plating Solution      | Sat'd | 75° F | YES                  | YES    | NO        |
| Bromine Water               | Sat'd | 75° F | YES                  | YES    | NO        |
| Butyl Alcohol               | Any   | 75° F | YES                  | YES    | NO        |
| Cadmium Plating Sol.        | Any   | 75° F | YES                  | YES    | NO        |
| Cadmium Bisulfate           | Any   | 75° F | YES                  | YES    | NO        |
| Calcium Chloride            | Sat'd | 75° F | YES                  | YES    | NO        |
| Calcium Hypochlorite        | Sat'd | 75° F | YES                  | YES    | NO        |
| Carbonic Acid               | Sat'd | 75° F | YES                  | YES    | NO        |
| Casein                      | Any   | 75° F | YES                  | YES    | NO        |
| Castor Oil                  | Any   | 75° F | YES                  | YES    | YES       |
| Caustic Soda                | 35%   | 75° F | YES                  | YES    | NO        |
| Caustic Soda                | 10%   | 75° F | YES                  | YES    | NO        |
| Caustic Potash              | 35%   | 75° F | YES                  | YES    | NO        |
| Caustic Potash              | 10%   | 75° F | YES                  | YES    | NO        |
| Chlorine Water              | Sat'd | 75° F | YES                  | YES    | NO        |
| Chromium Plating Sol.       | Any   | 75° F | YES                  | YES    | NO        |
| Citric Acid                 | Sat'd | 75° F | YES                  | YES    | NO        |
| Copper Chloride             | Sat'd | 75° F | YES                  | YES    | NO        |
| Copper Cyanide Plating Sol. | Any   | 75° F | YES                  | YES    | NO        |
| Copper Sulfate              | Sat'd | 75° F | YES                  | YES    | NO        |
| Coconut Oil                 | Sat'd | 75° F | YES                  | YES    | YES       |
| Cottonseed Oil              | Sat'd | 75° F | YES                  | YES    | YES       |
| Disodium Phosphate          | Sat'd | 75° F | YES                  | YES    | NO        |
| Ethyl Alcohol               | Any   | 75° F | YES                  | YES    | NO        |
| Ethylene Glycol             | Any   | 75° F | YES                  | YES    | YES       |
| Ferrous Sulfate             | Sat'd | 75° F | YES                  | YES    | NO        |
| Fluoboric Acid              | Any   | 75° F | YES                  | YES    | NO        |
| Formaldehyde                | 37%   | 75° F | YES                  | YES    | NO        |
| Formic Acid                 | 85%   | 75° F | YES                  | YES    | NO        |
| Gallic Acid                 | Sat'd | 75° F | YES                  | YES    | NO        |
| Glucose                     | Any   | 75° F | YES                  | YES    | YES       |
| Glycerine                   | Any   | 75° F | YES                  | YES    | YES       |
| Gold Plating Solution       | Any   | 75° F | YES                  | YES    | NO        |
| Hydrochloric Acid           | 10%   | 75° F | YES                  | YES    | NO        |
| Hydrochloric Acid           | 21.5% | 75° F | YES                  | YES    | NO        |
| Hydrochloric Acid           | 37.5% | 75° F | YES                  | YES    | NO        |
| Hydrofluoric Acid           | 4%    | 75° F | YES                  | YES    | NO        |
| Hydrofluoric Acid           | 10%   | 75° F | YES                  | YES    | NO        |
| Hydrofluoric Acid           | 48%   | 75° F | YES                  | YES    | NO        |
| Hydrogen Peroxide           | 30%   | 75° F | YES                  | YES    | NO        |
| Hydroquinone                | Any   | 75° F | YES                  | YES    | NO        |
| Indium Plating Solution     | Any   | 75° F | YES                  | YES    | NO        |
| Lactic Acid                 | Any   | 75° F | YES                  | YES    | NO        |
| Lead Plating Solution       | Any   | 75° F | YES                  | YES    | NO        |

| SOLUTIONS                     | CONC.       | TEMP. | RECOMMENDED EXPOSURE |        |           |
|-------------------------------|-------------|-------|----------------------|--------|-----------|
|                               |             |       | FUMES                | SPLASH | IMMERSION |
| Malic Acid                    | Any         | 75° F | YES                  | YES    | NO        |
| Methyl Alcohol                | Any         | 75° F | YES                  | YES    | NO        |
| Mineral Oils                  | Any         | 75° F | YES                  | YES    | YES       |
| Nickel Acetate                | Sat'd       | 75° F | YES                  | YES    | NO        |
| Nickel Plating Solution       | Any         | 75° F | YES                  | YES    | NO        |
| Nickel Salts                  | Sat'd       | 75° F | YES                  | YES    | NO        |
| Nitric Acid                   | 35%         | 75° F | YES                  | YES    | NO        |
| Nitric Acid                   | 40%         | 75° F | YES                  | YES    | NO        |
| Nitric Acid                   | 60%         | 75° F | YES                  | YES    | NO        |
| Nitric/Hydrofluoric Acid      | 15%/4%      | 75° F | YES                  | YES    | NO        |
| Nitric Acid/Sodium Dichromate |             |       |                      |        |           |
| Water                         | 16%/13%/71% | 75° F | YES                  | YES    | NO        |
| Oleic Acid                    | Any         | 75° F | YES                  | YES    | NO        |
| Oxalic Acid                   | Any         | 75° F | YES                  | YES    | NO        |
| Phenol                        | Sat'd       | 75° F | YES                  | YES    | NO        |
| Phosphoric Acid               | 75%         | 75° F | YES                  | YES    | NO        |
| Phosphoric Acid               | 85%         | 75° F | YES                  | YES    | NO        |
| Potassium Acid Sulfate        | Sat'd       | 75° F | YES                  | YES    | NO        |
| Potassium Antimonate          | Sat'd       | 75° F | YES                  | YES    | NO        |
| Potassium Bisulfite           | Sat'd       | 75° F | YES                  | YES    | NO        |
| Potassium Chloride            | Sat'd       | 75° F | YES                  | YES    | NO        |
| Potassium Cuprocyanide        | Sat'd       | 75° F | YES                  | YES    | NO        |
| Potassium Cyanide             | Sat'd       | 75° F | YES                  | YES    | NO        |
| Potassium Dichromate          | Sat'd       | 75° F | YES                  | YES    | NO        |
| Potassium Hypochlorate        | Sat'd       | 75° F | YES                  | YES    | NO        |
| Potassium Sulfide             | Sat'd       | 75° F | YES                  | YES    | NO        |
| Potassium Thiosulfate         | Sat'd       | 75° F | YES                  | YES    | NO        |
| Propyl Alcohol                | Sat'd       | 75° F | YES                  | YES    | NO        |
| Rhodium Plating Solution      | Sat'd       | 75° F | YES                  | YES    | NO        |
| Silver Plating Solution       | Sat'd       | 75° F | YES                  | YES    | NO        |
| Soaps                         | Any         | 75° F | YES                  | YES    | NO        |
| Sodium Acid Sulfate           | Sat'd       | 75° F | YES                  | YES    | NO        |
| Sodium Antimonate             | Sat'd       | 75° F | YES                  | YES    | NO        |
| Sodium Bicarbonate            | Sat'd       | 75° F | YES                  | YES    | NO        |
| Sodium Bisulfite              | Sat'd       | 75° F | YES                  | YES    | NO        |
| Sodium Chloride               | Sat'd       | 75° F | YES                  | YES    | NO        |
| Sodium Cyanide                | Sat'd       | 75° F | YES                  | YES    | NO        |
| Sodium Dichromate             | Sat'd       | 75° F | YES                  | YES    | NO        |
| Sodium Hydroxide              | 10%         | 75° F | YES                  | YES    | NO        |
| Sodium Hydroxide              | 35%         | 75° F | YES                  | YES    | NO        |
| Sodium Hydroxide              | 73%         | 75° F | YES                  | YES    | NO        |
| Sodium Hypochlorite           | Sat'd       | 75° F | YES                  | YES    | NO        |
| Sodium Hypochlorite           | 15%         | 75° F | YES                  | YES    | NO        |
| Sodium Sulfide                | Sat'd       | 75° F | YES                  | YES    | NO        |
| Sodium Thiosulfate            | Sat'd       | 75° F | YES                  | YES    | NO        |
| Sulfuric Acid                 | 15%         | 75° F | YES                  | YES    | NO        |
| Sulfuric Acid                 | 50%         | 75° F | YES                  | YES    | NO        |
| Sulfuric Acid                 | 70%         | 75° F | YES                  | YES    | NO        |
| Sulfuric Acid                 | 98%         | 75° F | YES                  | YES    | NO        |
| Sulfurous Acid                | 2%          | 75° F | YES                  | YES    | NO        |
| Sulfurous Acid                | 4%          | 75° F | YES                  | YES    | NO        |
| Tannic Acid                   | Sat'd       | 75° F | YES                  | YES    | NO        |
| Tartaric Acid                 | Sat'd       | 75° F | YES                  | YES    | NO        |
| Tin Chloride                  | Sat'd       | 75° F | YES                  | YES    | NO        |
| Tin Plating Solution          | Sat'd       | 75° F | YES                  | YES    | NO        |
| Triethanolamine               | Sat'd       | 75° F | YES                  | YES    | NO        |
| Trisodium Phosphate           | Sat'd       | 75° F | YES                  | YES    | NO        |
| White Liquor                  | Sat'd       | 75° F | YES                  | YES    | NO        |
| Zinc Plating Solution         | Sat'd       | 75° F | YES                  | YES    | NO        |
| Zinc Sulfate                  | Sat'd       | 75° F | YES                  | YES    | NO        |

# TECHNICAL INFORMATION

## PVC EXTERIOR COATING CHEMICAL RESISTANCE CHART

| SOLUTIONS                   | CONC. | TEMP. | RECOMMENDED EXPOSURE |        |           |
|-----------------------------|-------|-------|----------------------|--------|-----------|
|                             |       |       | FUMES                | SPLASH | IMMERSION |
| Acetic Acid                 | 10%   | 120   | NO                   | NO     | NO        |
| Acid Copper Plating Sol.    |       | 160   | YES                  | YES    | YES       |
| Alkaline Cleaners           |       | 160   | YES                  | YES    | YES       |
| Aluminum Chloride           | Sat'd | 160   | YES                  | YES    | YES       |
| Aluminum Sulfate            | Sat'd | 160   | YES                  | YES    | YES       |
| Alums                       | Sat'd | 160   | YES                  | YES    | YES       |
| Ammonium Chloride           | Sat'd | 160   | YES                  | YES    | YES       |
| Ammonium Hydroxide          | 28%   | 120   | YES                  | YES    | YES       |
| Ammonium Hydroxide          | 10%   | 120   | YES                  | YES    | YES       |
| Ammonium Sulfate            | Sat'd | 160   | YES                  | YES    | YES       |
| Ammonium Thiocyanate        | Sat'd | 160   | YES                  | YES    | YES       |
| Amyl Alcohol                | Any   | 90    | YES                  | YES    | YES       |
| Arsenic Acids               | Any   | 150   | YES                  | YES    | YES       |
| Barium Sulfide              | Sat'd | 160   | YES                  | YES    | YES       |
| Black Liquor                | Sat'd | 90    | YES                  | YES    | YES       |
| Benzoic Acid                | Sat'd | 160   | YES                  | YES    | YES       |
| Brass Plating Solution      | Any   | 160   | YES                  | YES    | YES       |
| Bromine Water               | Sat'd | 120   | YES                  | YES    | YES       |
| Butyl Alcohol               | Any   | 90    | YES                  | YES    | YES       |
| Cadmium Plating Sol.        | Any   | 150   | YES                  | YES    | YES       |
| Cadmium Bisulfate           | Any   | 150   | YES                  | YES    | YES       |
| Calcium Chloride            | Sat'd | 160   | YES                  | YES    | YES       |
| Calcium Hypochlorite        | Sat'd | 120   | YES                  | YES    | YES       |
| Carbonic Acid               | Sat'd | 160   | YES                  | YES    | YES       |
| Casein                      | Any   | 90    | YES                  | YES    | YES       |
| Castor Oil                  | Any   | 90    | YES                  | YES    | YES       |
| Caustic Soda                | 35%   | 120   | YES                  | YES    | YES       |
| Caustic Soda                | 10%   | 150   | YES                  | YES    | YES       |
| Caustic Potash              | 35%   | 120   | YES                  | YES    | YES       |
| Caustic Potash              | 10%   | 150   | YES                  | YES    | YES       |
| Chlorine Water              | Sat'd | 90    | YES                  | YES    | YES       |
| Chromium Plating Sol.       | Any   | 150   | YES                  | YES    | YES       |
| Citric Acid                 | Sat'd | 160   | YES                  | YES    | YES       |
| Copper Chloride             | Sat'd | 160   | YES                  | YES    | YES       |
| Copper Cyanide Plating Sol. | Any   | 160   | YES                  | YES    | YES       |
| (High Speed)                | Any   | 180   | YES                  | YES    | YES       |
| (with Alkali Cyanides)      | Sat'd | 160   | YES                  | YES    | YES       |
| Copper Sulfate              | Sat'd | 160   | YES                  | YES    | YES       |
| Coconut Oil                 | Sat'd | 90    | YES                  | YES    | YES       |
| Cottonseed Oil              | Sat'd | 90    | YES                  | YES    | YES       |
| Disodium Phosphate          | Sat'd | 160   | YES                  | YES    | YES       |
| Ethyl Alcohol               | Any   | 90    | YES                  | YES    | YES       |
| Ethylene Glycol             | Any   | 90    | YES                  | YES    | NO        |
| Ferric Chloride             | 45%   | 120   | YES                  | YES    | YES       |
| Ferrous Sulfate             | Sat'd | 150   | YES                  | YES    | YES       |
| Fluoboric Acid              | Any   | 150   | YES                  | YES    | YES       |
| Formaldehyde                | 37%   | 120   | YES                  | YES    | YES       |
| Formic Acid                 | 85%   | 100   | NO                   | NO     | NO        |
| Gallic Acid                 | Sat'd | 150   | YES                  | NO     | NO        |
| Glucose                     | Any   | 150   | YES                  | YES    | YES       |
| Glycerine                   | Any   | 90    | YES                  | YES    | YES       |
| Gold Plating Solution       | Any   | 150   | YES                  | YES    | YES       |
| Hydrochloric Acid           | 10%   | 120   | YES                  | YES    | YES       |
| Hydrochloric Acid           | 21.5% | 120   | YES                  | YES    | YES       |
| Hydrochloric Acid           | 37.5% | 120   | YES                  | YES    | NO        |
| Hydrochloric Acid           | 37.5% | 90    | YES                  | YES    | NO        |
| Hydrofluoric Acid           | 4%    | 140   | YES                  | YES    | NO        |
| Hydrofluoric Acid           | 10%   | 120   | YES                  | YES    | NO        |
| Hydrofluoric Acid           | 48%   | 120   | YES                  | YES    | NO        |
| Hydrogen Peroxide           | 30%   | 120   | YES                  | YES    | YES       |
| Hydrogen Sulfide            | Sat'd | 120   | YES                  | YES    | YES       |
| Hydroquinone                | Any   | 90    | YES                  | YES    | YES       |
| Indium Plating Solution     | Any   | 150   | YES                  | YES    | YES       |

| SOLUTIONS                     | CONC.       | TEMP. | RECOMMENDED EXPOSURE |        |           |
|-------------------------------|-------------|-------|----------------------|--------|-----------|
|                               |             |       | FUMES                | SPLASH | IMMERSION |
| Lactic Acid                   | 50%         | 120   | YES                  | YES    | YES       |
| Lactic Acid                   | Any         | 90    | YES                  | YES    | YES       |
| Lead Plating Solution         | Any         | 150   | YES                  | YES    | YES       |
| Malic Acid                    | Any         | 90    | YES                  | YES    | YES       |
| Methyl Alcohol                | Any         | 90    | YES                  | YES    | YES       |
| Mineral Oils                  | Any         | 90    | YES                  | YES    | YES       |
| Nickel Acetate                | Sat'd       | 160   | YES                  | YES    | YES       |
| Nickel Plating Solution       |             | 160   | YES                  | YES    | YES       |
| Nickel Salts                  | Sat'd       | 160   | YES                  | YES    | YES       |
| Nitric Acid                   | 35%         | 120   | YES                  | YES    | NO        |
| Nitric Acid                   | 40%         | 90    | YES                  | YES    | NO        |
| Nitric Acid                   | 60%         | 120   | YES                  | YES    | NO        |
| Nitric/Hydrofluoric Acid      | 15%/4%      | 140   | YES                  | YES    | YES       |
| Nitric Acid/Sodium Dichromate |             |       |                      |        |           |
| Water                         | 16%/13%/71% | 130   | YES                  | YES    | YES       |
| Oleic Acid                    | Any         | 90    | YES                  | YES    | YES       |
| Oxalic Acid                   |             | 90    | YES                  | YES    | YES       |
| Phenol                        | Sat'd       | 120   | NO                   | NO     | NO        |
| Phosphoric Acid               | 75%         | 150   | YES                  | YES    | YES       |
| Phosphoric Acid               | 85%         | 120   | YES                  | YES    | YES       |
| Potassium Acid Sulfate        | Sat'd       | 150   | YES                  | YES    | YES       |
| Potassium Antimonate          | Sat'd       | 150   | YES                  | YES    | YES       |
| Potassium Bisulfite           | Sat'd       | 90    | YES                  | YES    | YES       |
| Potassium Chloride            | Sat'd       | 160   | YES                  | YES    | YES       |
| Potassium Cuprocyanide        | Sat'd       | 150   | YES                  | YES    | YES       |
| Potassium Cyanide             | Sat'd       | 160   | YES                  | YES    | YES       |
| Potassium Dichromate          | Sat'd       | 160   | YES                  | YES    | YES       |
| Potassium Hypochlorate        | Sat'd       | 90    | YES                  | YES    | NO        |
| Potassium Sulfide             | Sat'd       | 150   | YES                  | YES    | YES       |
| Potassium Thiosulfate         | Sat'd       | 150   | YES                  | YES    | YES       |
| Propyl Alcohol                | Sat'd       | 150   | YES                  | YES    | YES       |
| Rhodium Plating Solution      | Sat'd       | 150   | YES                  | YES    | YES       |
| Silver Plating Solution       | Sat'd       | 150   | YES                  | YES    | YES       |
| Soaps                         | Any         | 90    | YES                  | YES    | YES       |
| Sodium Acid Sulfate           | Sat'd       | 160   | YES                  | YES    | YES       |
| Sodium Antimonate             | Sat'd       | 150   | YES                  | YES    | YES       |
| Sodium Bicarbonate            | Sat'd       | 160   | YES                  | YES    | YES       |
| Sodium Bisulfite              | Sat'd       | 90    | YES                  | YES    | YES       |
| Sodium Chloride               | Sat'd       | 160   | YES                  | YES    | YES       |
| Sodium Cyanide                | Sat'd       | 160   | YES                  | YES    | YES       |
| Sodium Dichromate             | Sat'd       | 160   | YES                  | YES    | YES       |
| Sodium Hydroxide              | 10%         | 150   | YES                  | YES    | NO        |
| Sodium Hydroxide              | 35%         | 120   | YES                  | YES    | NO        |
| Sodium Hydroxide              | 73%         | 160   | NO                   | NO     | NO        |
| Sodium Hypochlorite           | Sat'd       | 90    | YES                  | YES    | NO        |
| Sodium Hypochlorite           | 15%         | 120   | YES                  | YES    | NO        |
| Sodium Sulfide                | Sat'd       | 150   | YES                  | YES    | YES       |
| Sodium Thiosulfate            | Sat'd       | 150   | YES                  | YES    | YES       |
| Sulfuric Acid                 | 15%         | 120   | YES                  | YES    | YES       |
| Sulfuric Acid                 | 50%         | 120   | YES                  | YES    | YES       |
| Sulfuric Acid                 | 70%         | 90    | YES                  | YES    | NO        |
| Sulfuric Acid                 | 98%         | 100   | YES                  | NO     | NO        |
| Sulfurous Acid                | 2%          | 120   | YES                  | YES    | NO        |
| Sulfurous Acid                | 6%          | 120   | YES                  | YES    | NO        |
| Tannic Acid                   | Sat'd       | 90    | YES                  | YES    | YES       |
| Tartaric Acid                 | Sat'd       | 90    | YES                  | YES    | YES       |
| Tin Chloride                  | Sat'd       | 150   | YES                  | YES    | YES       |
| Tin Plating Solution          | Sat'd       | 150   | YES                  | YES    | YES       |
| Triethanolamine               | Sat'd       | 150   | YES                  | YES    | YES       |
| Trisodium Phosphate           | Sat'd       | 150   | YES                  | YES    | YES       |
| White Liquor                  | Sat'd       | 90    | YES                  | YES    | YES       |
| Zinc Plating Solution         |             | 160   | YES                  | YES    | YES       |
| Zinc Sulfate                  | Sat'd       | 160   | YES                  | YES    | YES       |

# TECHNICAL INFORMATION

## PLASTI-BOND REDH<sub>2</sub>O<sub>T</sub> SPECIFICATION

1. The PVC coated galvanized rigid conduit must be UL Listed. The PVC coating must have been investigated by UL as providing the primary corrosion protection for the rigid metal conduit. Ferrous fittings for general service locations must be UL Listed with PVC as the primary corrosion protection. Hazardous location fittings, prior to plastic coating must be UL listed. All conduit and fittings must be new, unused material. Applicable UL standards may include: UL 6 Standard for Safety, Rigid Metal Conduit, UL514B Standard for Safety, Fittings for Conduit and Outlet Boxes.
2. The PVC coated galvanized rigid conduit must be ETL Verified to the Intertek ETL SEMKO High Temperature H<sub>2</sub>O PVC Coating Adhesion Test Procedure for 200 hours. The PVC coated galvanized rigid conduit must bear the ETL Verified PVC-001 label to signify compliance to the adhesion performance standard.
3. The conduit shall be hot dip galvanized inside and out with hot galvanized threads.
4. A PVC sleeve extending one pipe diameter or two inches, whichever is less, shall be formed at every female fitting opening except unions. The inside sleeve diameter shall be matched to the outside diameter of the conduit.
5. The PVC coating on the outside of conduit couplings shall have a series of longitudinal ribs 40 mils in thickness to protect the coating from tool damage during installation.
6. Form 8 Condulets, 1/2" through 2" diameters, shall have a tongue-in-groove gasket to effectively seal against the elements. The design shall be equipped with a positive placement feature to ease and assure proper installation. Certified results confirming seal performance at 15 psig (positive) and 25 in. of mercury (vacuum) for 72 hours shall be available.
7. Form 8 Condulets shall be supplied with plastic encapsulated stainless steel cover screws.
8. A red urethane coating shall be uniformly and consistently applied to the interior of all conduit and fittings. This internal coating shall be a nominal 2 mil thickness. Conduit or fittings having areas with thin or no coating shall be unacceptable.
9. The PVC exterior and urethane interior coatings applied to the conduit shall afford sufficient flexibility to permit field bending without cracking or flaking at temperatures above 30°F (-1°C).
10. All male threads on conduit, elbows and nipples shall be protected by application of a urethane coating.
11. All female threads on fittings or conduit couplings shall be protected by application of a urethane coating.
12. Independent certified test results shall be available to confirm coating adhesion under the following conditions:
  - A. Conduit and conduit exposure to 150°F (65°C) and 95% relative humidity with a minimum mean time to failure of 30 days. (ASTM D1151)
  - B. The interior coating bond shall be confirmed using the Standard Method of Adhesion by Tape Test (ASTM D3359).
  - C. No trace of the internal coating shall be visible on a white cloth following six wipes over the coating which has been wetted with acetone (ASTM D1308).
  - D. The exterior coating bond shall be confirmed using the methods described in Section 3.8, NEMA RN1. After these tests the physical properties of the exterior coating shall exceed the minimum requirements specified in Table 3.1, NEMA RN1.
13. Right angle beam clamps and U bolts shall be specially formed and sized to snugly fit the outside diameter of the coated conduit. All U bolts will be supplied with plastic encapsulated nuts that cover the exposed portions of the threads.
14. Installation of the Plasti-Bond Conduit System shall be performed in accordance with the Plasti-Bond Installation Manual. To assure correct installation, the installer shall be certified by Plasti-Bond to install coated conduit.
15. Approved Material: Plasti-Bond Coated galvanized rigid conduit and Fittings as manufactured by Plasti-Bond, Gilmer, Texas. Any deviation from the above specifications must be approved by the engineer/owner.

## PLASTI-BOND REDH<sub>2</sub>O<sub>T</sub> ABRIDGED SPECIFICATION

The PVC coated galvanized rigid conduit must be UL Listed. The PVC coating must have been investigated by UL as providing the primary corrosion protection for the rigid metal conduit. The PVC coated conduit must be ETL Verified to the Intertek ETL SEMKO High Temperature H<sub>2</sub>O PVC Coating Adhesion Test Procedure for 200 hours. The PVC coated conduit must bear the ETL Verified PVC-001 label to signify compliance to the adhesion performance standard. Ferrous fittings for general service locations must be UL Listed with PVC as the primary corrosion protection. Hazardous location fittings, prior to plastic coating must be UL listed. All conduit and fittings must be new, unused material. Applicable UL standards may include: UL 6 Standard for Safety, Rigid Metal Conduit, UL514B Standard for Safety, Fittings for Conduit and Outlet Boxes. Conduit and fittings shall be evaluated for reliability and performance.

Certified test results are the respective test data that have been witnessed and certified to be accurate by an independent, recognized third party.

1. Acceptable conduit and fitting PVC bonds shall be confirmed with a minimum average of 30 days in a heat and humidity test (ASTM D1151 and D2247) with the temperature at 150°F (66°C) and 95% relative humidity.
2. Acceptable seal performance shall be confirmed at 15 psig (positive) and 25 in. of mercury (vacuum) for 72 hours. Contact local PLASTI-BOND Sales Representatives for third party testing certification and procedure methods.



# TECHNICAL INFORMATION

## PLASTI-BOND REDH<sub>2</sub>OT PERFORMANCE STANDARDS/DESCRIPTIONS

Exterior PVC and interior urethane coating performance shall be confirmed by the characteristics and tests listed below. Test samples shall be selected at random.

### FLAMMABILITY

The PVC coating will burn if subjected to sustained flame or heat above 400°F, however, it will self extinguish upon removal of the heat source or flame.

### TOXICITY

Prolonged exposure to heat greater than 200°F or exposure to fire may cause the PVC coating to release harmful emissions which could pose a potential health hazard. Therefore, PVC use is not recommended in areas exposed to sustained temperatures above 200°F. If exposed to fire, particularly in closed areas, users should be aware and observe proper caution.

### BOIL TEST

Acceptable conduit coating bonds shall be confirmed if there is no disbondment after a minimum average of 200 hours in boiling water or exposure to steam vapor at one atmosphere. The periodic increments between bond tests shall not exceed 5 hours for the first 25 hours, then it may be lengthened by mutual consent. The RN1 Bond Test and the Standard Method for Measuring Adhesion by Tape Test shall be utilized.

#### *Exterior Adhesion*

A 6" length of conduit test specimen shall be placed in boiling water. The specimen shall be periodically removed, cooled to ambient temperature and immediately tested according to the bond test (RN1). When the PVC coating separates from the substrate, the boil time to failure in hours shall be recorded. ASTM D870 describes this test method for accelerated testing of coating adhesive bonds.

#### *Interior Adhesion*

A 6" conduit test specimen shall be cut in half longitudinally and placed in boiling water or directly above boiling water with the urethane surface facing down. The specimen shall be periodically removed, cooled to ambient temperature and tested in accordance with the Standard Method of Adhesion by Tape Test (ASTM D3359). When the coating disbonds, the time to failure in hours shall be recorded.

### HEAT/HUMIDITY TEST

Acceptable conduit coating bonds shall be confirmed by a minimum average of 30 days in the Heat and Humidity Test. The periodic increment between bond tests shall not exceed 5 days for the first 30 days, then may be lengthened by mutual consent. The RN1 Bond Test and the Standard Method for Measuring Adhesion by Tape Test shall be utilized.

#### *Exterior Adhesion*

Conduit specimens shall be placed in a heat and humidity environment where the temperature is maintained at 150°F (66°C) and 95% relative humidity. The specimens shall be periodically removed and a bond test (RN1) performed. When the PVC coating separates from the substrate, the exposure time to failure in days shall be recorded. ASTM D1151, D1735, D2247 AND D4585 are the basis for this accelerated method of evaluating adhesive bonding.

#### *Interior Adhesion*

The conditions for interior adhesion testing of conduit specimens are the same as those for external adhesion. ASTM D3359 is used to determine adhesive failure.

### ETL-VERIFIED PVC-001:

The PVC coating adhesion performance of this product has been ETL verified to the Interek ETL SEMKO High Temperature H<sub>2</sub>O PVC Coating Adhesion Test Procedure for 200 hours.

### CHEMICAL RESISTANCE TEST

No trace of the internal coating shall be visible on a white cloth following six wipes over the coating which has been wetted with acetone (ASTM D1308).

### POLYURETHANE

The supplier shall confirm that the internal coating which meets the above condition is a polyurethane.

Plasti-Bond has used the American Society for Testing and Materials (ASTM) standards to provide comparable and consistent test data. A list of ASTM standards referenced in the Plasti-Bond REDH<sub>2</sub>OT Coated Conduit Specification appears below.

### ASTM D149

Test Methods for Dielectric Breakdown Voltage and Dielectric Strength of Solid Electrical Insulating Materials at Commercial Power Frequencies

### ASTM D638

Test Method for Tensile Properties of Plastics

### ASTM D746

Test Method for Brittleness Temperature of Plastics and Elastomers by Impact

### ASTM D870

Method for Water Immersion Test of Organic Coatings on Steel

### ASTM D1151

Test Method for Effect of Moisture and Temperature on Adhesive Bonds

### ASTM D1735

Method for Water Fog Testing of Organic Coatings

### ASTM D2240

Test Method for Rubber Property-Durometer Hardness

### ASTM D2247

Method of Testing Coated Metal Specimens at 100% Relative Humidity

### ASTM D3359

Method for Measuring Adhesion by Tape Test

### ASTM D4585

Testing Water Resistance of Coatings Using Controlled Condensation

### ASTM G23

Recommended Practice for Operating Light-and-Water-Exposure Apparatus (Carbon-Arc Type) for Exposure of Non-Metallic Materials

### ASTM D1308

Effect of Chemicals on Clear and Pigmented Organic Finishes



**Plasti-Bond REDH<sub>2</sub>OT PVC Coated Products**

**PAGE**

---

|                                                          |              |
|----------------------------------------------------------|--------------|
| Conduit and Nipples.....                                 | 1-2          |
| Standard Radius Elbows.....                              | 3-4          |
| Large Radius Elbows.....                                 | 4            |
| Pulling Elbows.....                                      | 5            |
| Couplings.....                                           | 6            |
| Conduit Bodies For General Service Locations.....        | 7-12         |
| Cast Device Boxes.....                                   | 13-18        |
| Conduit Boxes For Hazardous Locations.....               | 19-21        |
| Sealing Fittings.....                                    | 22-25        |
| Knockout Hubs.....                                       | 26-27        |
| Conduit Unions.....                                      | 28           |
| Malleable Elbows.....                                    | 29           |
| Service Entrance Elbows.....                             | 30           |
| Expansion Joints.....                                    | 31           |
| Liquid Tight Connectors.....                             | 32-33        |
| Reducing Couplings and Split Couplings.....              | 34           |
| Plugs, Grounding Bushings, Reducing Bushings.....        | 35           |
| Pipe Straps & Clamp Back Spacers.....                    | 36-37        |
| Clamp Hangers.....                                       | 36           |
| Thread Rods.....                                         | 36           |
| Strut Nuts.....                                          | 37           |
| Pipe Straps.....                                         | 37           |
| Strut.....                                               | 37           |
| Beam Clamps.....                                         | 38           |
| U-Bolts.....                                             | 38           |
| Installation Tools.....                                  | 39           |
| Plasti-Bond REDH <sub>2</sub> OT Touch-up Compounds..... | 39           |
| <br>                                                     |              |
| <b>Installation Guide.....</b>                           | <b>40-46</b> |
| <br>                                                     |              |
| <b>Technical Information.....</b>                        | <b>47-50</b> |

**General Disclaimers**

1. All weights and dimensions are approximate and are subject to change without notice.
2. Plasti-Bond reserves the right to make engineering changes as needed.
3. Catalog numbers are not intended to represent specific manufacturers.
4. Unless indicated otherwise all weights and measures are in inch-pound units.
5. Please see current Price Guide for product availability.





# Plasti-Bond **REDH<sub>2</sub>OT**

Price: \$5.00

**PR-110**

---

## Executive Offices:

1100 US Highway 271 South

Gilmer, Texas 75644

Phone: 903/843-5591

Sales Department Fax: 903/843-2516

©2012 Robroy Industries Electrical Products Division

Effective Date: 03/12

Order Item: 10PR-110



Robroy Industries Coated Conduit has been recognized for customer satisfaction excellence under the J.D. Power and Associates Certified Call Center Program.

For J.D. Power and Associates 2009 Certified Call Center Program information, visit [www.jdpower.com](http://www.jdpower.com).