















Unilet® Conduit Bodies and Boxes

| | | Page | Description |
|---|---|-------|--|
|  |  | 2-16 | Form 35® Malleable Iron, and Form 85™ Aluminum, FM7™, FM8® and FM9™ Grayloy™, FM7™ Aluminum Conduit Outlet Bodies |
| FM7 Series | FM8 Series | 2-6 | Form 35 Bodies Covers/Gaskets and Dimensions |
|  |  | 7-11 | Form 85 Bodies Covers/Gaskets and Dimensions |
| Form 35 Compression | Form 35 | 12-16 | FM7 Series Bodies/Covers/Gaskets and Dimensions |
|  |  | 17-20 | FM8 Series Bodies/Covers/Gaskets and Dimensions |
| Form 85 Threaded | Form 85 Setscrew | 21-24 | FM9 Series Bodies/Covers/Gaskets and Dimensions |
|  |  | 25-32 | Mogul Malleable Iron and Aluminum Conduit Outlet Bodies— NEC 6x8x Series and LL, LR and T |
| Mogul—Type LB | Big Bend™ Casting Pulling Elbow | 25 | Features |
|  | | 26 | Bodies and Covers |
| Mogul—Type UB | | 27 | Bending Radii and Bending Space |
|  | | 28-31 | NEC 6x8x Pull Charts and Dimensions |
| LBD/LBDN | | 32 | Wiring Capacity Tables |
|  | | 33 | LBD and LBDN Malleable Iron and Aluminum Pulling Unilets |
| JB | | 33 | Features; Bodies, Covers and Dimensions; Wiring Capacity Tables |
|  | | 34-35 | JB Conduit Outlet Boxes |
| GS | | 34 | Features |
|  | | 34-35 | JBX, JBDX, JBLX Boxes, Covers, Fixture Hangers, and Accessories |
| SEH | | 35 | Dimensions and Wiring Capacity Tables |
|  | | 36-37 | GS Conduit Outlet Boxes |
| Type PTC | | 36 | Features |
| | | 36-37 | GS Boxes, Covers, Fixture Hangers, Gaskets, and Accessories |
| | | 37 | Dimensions and Wiring Capacity Tables |
| | | 38 | SEH Conduit Outlet Boxes |
| | | 38 | Features; SEH Boxes, Covers and Dimensions; Wiring Capacity Tables |
| | | 39 | Pull Boxes with Threaded Hubs & Covers |
| | | 40-41 | Big Bend™ Cast Pulling Elbow |
| | | 40 | Features |
| | | 41 | Bending Radii and Dimensions |

Form 35® Unilet® Conduit Outlet Bodies

For use with Rigid Steel, Rigid Aluminum, IMC, and EMT Conduit.

Applications

- Serve as pulling fittings.
- Make bends in conduit system.
- Provide openings for splicing.
- Connect and change direction of conduit runs.
- Allow connections for branch runs.
- Permit access to conductors for maintenance.

Features: Unilet® conduit outlet bodies

- Roomy interiors: more wiring space.
- Smooth, rounded integral bushings in hubs protect conductor insulation.
- Accurately tapped, tapered threads for tight, rigid joints and excellent ground continuity.

Features: Form 35®

- Form 35 malleable iron Unilets: high tensile strength and ductility. High corrosion-resistance, high impact and shock resistance.
- Exclusive built-in easy-pulling rollers in type C (1-1/4" thru 4") and type LB (1-1/4" thru 4")— eliminate damage when cable is pulled through hubs.
- Sizes with flat-back design ideal where fitting is mounted flat against surface.
- Complete line of conduit bodies, covers and receptacles.
- Blank covers domed for extra wiring space.

Standard Materials

- *Form 35 Unilet conduit outlet bodies:* malleable iron.
- *Covers:* blank— malleable iron, steel and aluminum. Duplex grounding receptacle— phenolic. Lamp receptacle— porcelain. Wiring device and switch covers— aluminum. Cover screws: stainless steel.
- *Gaskets:* neoprene or composition fiber.

Standard Finishes

- *Malleable iron bodies:* triple-coat— (1) zinc electroplate, (2) dichromate, and (3) epoxy powder coat.
- *Covers:* steel: zinc electroplate. Malleable iron: triple-coat— (1) zinc electroplate, (2) dichromate, and (3) epoxy powder coat.



Form 35



Form 35



● Form 35 Malleable.
2" Type LB with rollers shown.

Compliances

- UL Standard 514A.
- Federal Spec. W-C-586B.
- Suitable for classified location use in Class I, Division 2 areas, if installed in compliance with NEC 501-4(b).
- Appleton malleable iron products conform to ASTM A47-77, Grade 32510, which has the following properties: tensile strength, 50,000 psi; yield, 32,000 psi; and elongation, 10%.
- Appleton aluminum products are produced from a high strength copper-free (4/10 of 1% max.) alloy.
- Appleton Grayloy-iron products are a gray iron alloy with tensile strength similar to ASTM-A48 Class 30A (30,000 psi tensile), and with a Brinell hardness of approximately 180BH.





Product Cross Reference





- For explosionproof conduit outlet bodies and boxes, see Cat. Section J.
- For Mogul Unilets®, see pages A-17 through A-24.

Form 35[®] Malleable Iron Unilet[®] Conduit Outlet Bodies

Threaded Type for use with Rigid Metal Conduit and IMC;
Compression Type for use with Threadless Rigid Metal Conduit.

Appleton Form 35[®] Threaded Type Conduit Bodies NOTE: Refer to page A-16 for Wiring Capacity Tables

| Hub Size (in.) |  C |  E |  LB |  LL |  LR |
|----------------|---|---|--|--|--|
| 1/2 | C50-M | E50-M | LB50-M | LL50-M | LR50-M |
| 3/4 | C75-M | E75-M | LB75-M | LL75-M | LR75-M |
| 1 | C100-M | E100-M | LB100-M | LL100-M | LR100-M |
| 1-1/4 | C125-M◇ | E125-M | LB125-M◇ | LL125-M | LR125-M |
| 1-1/2 | C150-M◇ | E150-M | LB150-M◇ | LL150-M | LR150-M |
| 2 | C200-M◇ | — | LB200-M◇ | LL200-M | LR200-M |
| 2-1/2 | C250-M◇ | — | LB250-M◇ | LL250-M | LR250-M |
| 3 | C300-M◇ | — | LB300-M◇ | LL300-M | LR300-M |
| 3-1/2 | C350-M◇ | — | LB350-M◇ | LL350-M | LR350-M |
| 4 | C400-M◇ | — | LB400-M◇ | LL400-M | LR400-M |
| 5 | — | — | LB500-M | — | — |
| 6 | — | — | LB600-M | — | — |

| Hub Size (in.) |  LRL* |  T |  TA |  TB |  X |
|----------------|--|---|--|--|---|
| 1/2 | LRL50-M | T50-M | TA50-M | TB50-M | X50-M |
| 3/4 | LRL75-M | T75-M | TA75-M | TB75-M | X75-M |
| 1 | LRL100-M | T100-M | TA100-M | TB100-M | X100-M |
| 1-1/4 | LRL125-M | T125-M | — | TB125-M | X125-M |
| 1-1/2 | LRL150-M | T150-M | — | TB150-M | X150-M |
| 2 | LRL200-M | T200-M | — | TB200-M | X200-M |
| 2-1/2 | — | T250-M | — | — | — |
| 3 | — | T300-M | — | — | — |
| 3-1/2 | — | T350-M | — | — | — |
| 4 | — | T400-M | — | — | — |

*LRL Unilets have double opening and are furnished with one steel cover, assembled.
◇ Catalog numbers having patented roller feature, all others do not.

Compression Type—For use with Threadless Rigid Metal Conduit

| Hub Size (in.) |  LB |  LRL* |  T |
|----------------|--|--|---|
| 1/2 | LB50N-M | LRL50N-M | T50N-M |
| 3/4 | LB75N-M | LRL75N-M | T75N-M |
| 1 | LB100N-M | LRL100N-M | T100N-M |

Back Style for Form 35 Unilet conduit body sizes (inches)

| Unilet Body | Flat Back | Round Back |
|-------------|--------------|----------------|
| C, LB | 1/2 - 2 | 2-1/2 and up |
| E | 1/2 - 1-1/2 | 1-1/4 and up |
| LL, LR, T | 1/2 - 2 | 2-1/2 and up |
| TB | 1-1/4, 1-1/2 | 1/2, 3/4, 1, 2 |
| X | 1/2 - 1 | 1-1/4 and up |





All TA Unilets are round back design.
All Compression Type are flatback design.

A-4

Covers and Gaskets for Form 35® Unilet® Conduit Outlet Bodies



Covers Furnished with Stainless Steel Fastening Screws.

Appleton Form 35® Covers and Gaskets NOTE: Refer to page A-16 for Wiring Capacity Tables.

| Size | Blank Stamped Steel | Blank Cast Malleable | Neoprene | Composition Fiber |
|-------------------------------|--|--|--|---|
| Form 35 Body Size (in.) |  Domed: 1/2" - 3" Flat: 3-1/2" - 6" |  Flat: 1/2" - 2" Domed: 2-1/2" - 4" |  Tear out inner perforated section to convert to "open type" gasket. |  |
| 1/2 | K50 | K50-CM | GK50-N | GK50-V |
| 3/4 | K75 | K75-CM | GK75-N | GK75-V |
| 1 | K100 | K100-CM | GK100-N | GK100-V |
| 1-1/4 | K125 & 150 | K125 & 150-CM | GK125-150-N | GK125-150-V |
| 1-1/2 | K125 & 150 | K125 & 150-CM | GK125-150-N | GK125-150-V |
| 2 | K200 | K200-CM | GK200-N | GK200-V |
| 2-1/2 | K250 & 300 | K250 & 300-CM | GK250-300-N | GK-250-300-V |
| 3 | K250 & 300 | K250 & 300-CM | GK250-300-N | GK-250-300-V |
| 3-1/2 | K350 & 400 | K350 & 400-CM | GK350-400-N | GK-350-400-V |
| 4 | K350 & 400 | K350 & 400-CM | GK350-400-N | GK-350-400-V |
| 5 | K500 | — | GK500-SN† | |
| 6 | K600 | — | GK600-SN† | |

† Not perforated

Wiring Device Covers

| | | | |
|---|--|--|----------------|
|  Lamp Receptacle with 1-1/2" Shade Holder Groove. Porcelain, 600 Watt, 600 Volt Rating Form 35 Body Size (in.) Cat. No. |  Device Cover for Interchangeable (Despard) Wiring Devices, Cast Aluminum with Mounting Strap Form 35 Body Size (in.) Cat. No. |  Switch Cover for Interchangeable (Despard) Devices, Cast Aluminum with Gasket and Steel Mounting Strap Form 35 Body Size (in.) Cat. No. | |
| 1/2 3/4 | KLR50 KLR75 | 1/2 KWD50-A | 3/4 KVS75-A |

Dimensions: Form 35[®] Malleable Iron Unilet[®] Conduit Outlet Bodies

Threaded Type for use with Rigid Metal Conduit and IMC;
Compression Type for use with Threadless Rigid Metal Conduit.

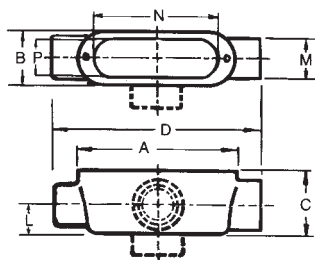

Types A, C, TA, TB

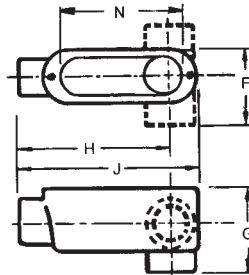

Types E, LB, LL, LR, LRL

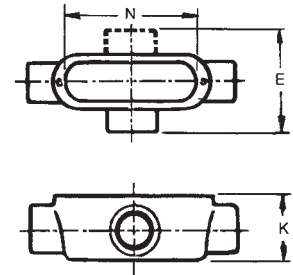

Types T, X

Fraction/Decimal Equivalents (Inches)

| Fraction | Decimal | Fraction | Decimal | Fraction | Decimal | Fraction | Decimal |
|----------|---------|----------|---------|----------|---------|----------|---------|
| 1/16 | 0.06 | 5/16 | 0.31 | 9/16 | 0.56 | 13/16 | 0.81 |
| 1/8 | 0.13 | 3/8 | 0.38 | 5/8 | 0.63 | 7/8 | 0.88 |
| 3/16 | 0.19 | 7/16 | 0.44 | 11/16 | 0.69 | 15/16 | 0.94 |
| 1/4 | 0.25 | 1/2 | 0.50 | 3/4 | 0.75 | 1 | 1.00 |

Threaded Type Dimensions in Inches

| Hub Size | A | B | C | D | E | F | G | H | J | K | L | M | N | P |
|----------|-------|------|------|-------|------|------|-------|-------|-------|------|------|------|-------|------|
| 1/2 | 3.94 | 1.31 | 1.44 | 5.38 | 2.69 | 2.00 | 2.13 | 3.94 | 4.63 | 1.75 | .63 | 1.19 | 3.16 | 1.00 |
| 3/4 | 4.63 | 1.56 | 1.69 | 6.06 | 2.88 | 2.19 | 2.31 | 4.44 | 5.38 | 2.00 | .75 | 1.38 | 3.78 | 1.22 |
| 1 | 5.38 | 1.81 | 1.94 | 7.13 | 3.38 | 2.56 | 2.69 | 5.13 | 6.25 | 2.25 | .94 | 1.69 | 4.53 | 1.47 |
| 1-1/4 | 7.19 | 2.50 | 2.56 | 9.19 | 4.50 | 3.50 | 3.56 | 7.06 | 8.19 | 2.56 | 1.19 | 2.00 | 6.00 | 2.00 |
| 1-1/2 | 7.19 | 2.50 | 2.75 | 9.19 | 4.50 | 3.50 | 3.75 | 6.81 | 8.19 | 2.75 | 1.38 | 2.38 | 6.00 | 2.00 |
| 2 | 9.50 | 3.13 | 3.38 | 11.63 | 5.25 | 4.19 | 4.63 | 8.94 | 10.56 | 3.38 | 1.63 | 2.94 | 8.06 | 2.56 |
| 2-1/2 | 12.25 | 4.31 | 3.88 | 15.13 | 7.19 | 5.75 | 5.25 | 11.88 | 13.69 | 3.88 | 1.81 | 3.38 | 10.63 | 3.69 |
| 3 | 12.25 | 4.31 | 4.63 | 15.13 | 7.19 | 5.75 | 6.00 | 11.56 | 13.69 | 4.63 | 2.19 | 4.13 | 10.63 | 3.69 |
| 3-1/2 | 14.88 | 5.50 | 5.19 | 18.13 | 8.75 | 7.13 | 6.81 | 14.00 | 16.50 | 5.19 | 2.50 | 4.75 | 13.13 | 4.88 |
| 4 | 14.88 | 5.50 | 5.56 | 18.13 | 8.75 | 7.13 | 7.19 | 13.75 | 16.50 | 5.56 | 2.75 | 5.13 | 13.13 | 4.88 |
| 5 | 18.25 | 7.25 | 7.00 | | | | 9.00 | 16.88 | 20.25 | | 3.38 | 6.50 | 16.25 | 6.50 |
| 6 | 23.00 | 8.63 | 8.69 | | | | 10.69 | 21.06 | 25.00 | | 3.94 | 7.56 | 21.00 | 7.81 |

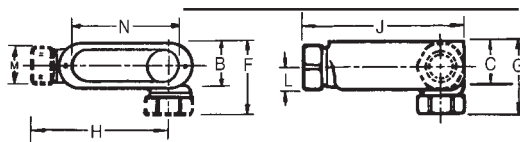

Types LB, LRL

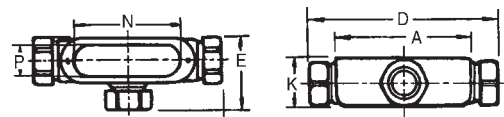

Type T

Compression Type Dimensions in Inches

| Hub Size | A | B | C | D | E | F | G | H | J | K | L | M | N | P |
|----------|------|------|------|------|------|------|------|------|------|------|-----|------|------|------|
| 1/2 | 3.94 | 1.31 | 1.44 | 6.06 | 2.38 | 2.38 | 2.50 | 4.31 | 5.00 | 1.75 | .63 | 1.31 | 3.16 | 1.00 |
| 3/4 | 4.63 | 1.56 | 1.69 | 6.81 | 2.69 | 2.69 | 2.81 | 4.81 | 5.75 | 2.00 | .75 | 1.63 | 3.78 | 1.22 |
| 1 | 5.38 | 1.81 | 1.94 | 7.63 | 2.94 | 2.94 | 3.06 | 5.38 | 6.50 | 2.25 | .94 | 1.88 | 4.53 | 1.47 |

A-6

Wiring Capacity: Form 35® Conduit Bodies and Covers

Combine Body and Cover Capacities for Total usable Capacity
per NEC 370-6(a)(1)

Form 35® Malleable Iron Bodies and Covers: Threaded and Compression

| Capacity in Cubic Inches | | | | | | | | | | | |
|--------------------------|-------|------|--------|----------|------|-------|------|------|------|------------------|---------------|
| Hub Size (In.) | C | E | LB | LL LR | LRL | T | TA | TB | X | Stamped Cover | Cast Cover |
| 1/2 | 4.5 | 4.5 | 4.5 | 4.5 | 5.0 | 6.0 | 4.3 | 4.3 | 6.0 | 0.5 | 0 |
| 3/4 | 7.5 | 7.5 | 7.5 | 7.5 | 8.8 | 9.5 | 7.0 | 7.0 | 9.5 | 0.8 | 0.3 |
| 1 | 12.5 | 12.5 | 12.5 | 12.5 | 14.3 | 15.0 | 15.0 | 13.0 | 15.0 | 1.0 | 0.5 |
| 1-1/4 | 35.0 | 29.3 | 32.3 | 32.0 | 34.8 | 33.0 | — | 35.0 | 31.5 | 2.5 | 0.8 |
| 1-1/2 | 35.3 | 32.5 | 35.3 | 35.3 | 40.0 | 36.0 | — | 35.3 | 40.0 | 2.5 | 0.8 |
| 2 | 75.0 | — | 73.0 | 73.0 | 85.0 | 71.0 | — | 71.0 | 71.0 | 6.5 | 1.5 |
| 2-1/2 | 143.0 | — | 139.0 | 140.5 | — | 146.0 | — | — | — | 18.0 | 30.0 |
| 3 | 180.0 | — | 177.0 | 175.0 | — | 185.0 | — | — | — | 18.0 | 30.0 |
| 3-1/2 | 303.0 | — | 300.0 | 300.0 | — | 314.0 | — | — | — | — | 50.0 |
| 4 | 340.0 | — | 330.0 | 330.0 | — | 345.0 | — | — | — | — | 50.0 |
| 5 | — | — | 756.0 | — | — | — | — | — | — | — | — |
| 6 | — | — | 1328.0 | — | — | — | — | — | — | — | — |

Form 85™ Unilet® Conduit Outlet Bodies

For use with Rigid Steel, Rigid Aluminum, IMC, and EMT Conduit.

Applications

- Serve as pulling fittings.
- Make bends in conduit system.
- Provide openings for splicing.
- Connect and change direction of conduit runs.
- Allow connections for branch runs.
- Permit access to conductors for maintenance.

Features: Unilet® conduit outlet bodies

- Roomy interiors: more wiring space.
- Smooth, rounded integral bushings in hubs protect conductor insulation.
- Accurately tapped, tapered threads for tight, rigid joints and excellent ground continuity.

Features: Form 85™

- Form 85 aluminum Unilets: copper-free aluminum (max. 4/10 of 1% copper content). Lightweight, high corrosion resistance. Self-oxidizing, self-renewing.
- Lightweight aluminum facilitates shipping, handling and installing.
- Sizes with flat-back design ideal where fitting is mounted flat against surface.
- Complete line of conduit bodies, covers and receptacles.
- Blank covers domed for extra wiring space.

Standard Materials

- *Unilet conduit outlet bodies:* aluminum— copper-free (max. 4/10 of 1%). 1/2" thru 2"— pressure cast. 2-1/2" thru 4"— sand cast.
- *Covers:* blank— malleable iron, steel and aluminum. Duplex grounding receptacle— phenolic. Lamp receptacle— porcelain. Wiring device and switch covers— aluminum. Cover screws: stainless steel.
- *Gaskets:* neoprene or composition fiber.

Standard Finishes

- *Aluminum bodies:* epoxy powder coat.
- *Stamped aluminum covers:* natural finish.
- *Cast aluminum covers:* epoxy powder coat.



Form 85



Form 85 Aluminum Conduit Body with Stamped Aluminum Cover. 2" Type C shown.

Compliances

- UL Standard 514A.
- Federal Spec. W-C-586B.
- Suitable for classified location use in Class I, Division 2 areas, if installed in compliance with NEC 501-4(b).
- Appleton malleable iron products conform to ASTM A47-77, Grade 32510, which has the following properties: tensile strength, 50,000 psi; yield, 32,000 psi; and elongation, 10%.
- Appleton aluminum products are produced from a high strength copper-free (4/10 of 1% max.) alloy.
- Appleton Grayloy-iron products are a gray iron alloy with tensile strength similar to ASTM-A48 Class 30A (30,000 psi tensile), and with a Brinell hardness of approximately 180BH.

Product Cross Reference

- For explosionproof conduit outlet bodies and boxes, see Cat. Section J.
- For Mogul Unilets®, see pages A-17 through A-24.

Form 85™ Aluminum Unilet® Conduit Outlet Bodies

Threaded Type for use with Rigid Metal Conduit and IMC.
Setscrew Type for use with Electrical Metal Tubing (EMT).

Appleton Form 85™ Conduit Bodies: Threaded/SetScrew Type NOTE: Refer to page A-16 for Wiring Capacity Tables

| Hub Size (in.) | C | | E | | LB | | LL | | LR | |
|----------------|---------------|---------------|---------------|---------------|---------------|---------------|---------------|---------------|---------------|---------------|
| | Threaded Type | Setscrew Type | Threaded Type | Setscrew Type | Threaded Type | Setscrew Type | Threaded Type | Setscrew Type | Threaded Type | Setscrew Type |
| 1/2 | C50-A | C50T-A | E50-A | E50T-A | LB50-A | LB50T-A | LL50-A | LL50T-A | LR50-A | LR50T-A |
| 3/4 | C75-A | C75T-A | E75-A | — | LB75-A | LB75T-A | LL75-A | LL75T-A | LR75-A | LR75T-A |
| 1 | C100-A | C100T-A | E100-A | — | LB100-A | LB100T-A | LL100-A | LL100T-A | LR100-A | LR100T-A |
| 1-1/4 | C125-A | C125T-A | — | — | LB125-A | LB125T-A | LL125-A | LL125T-A | LR125-A | LR125T-A |
| 1-1/2 | C150-A | C150T-A | — | — | LB150-A | LB150T-A | LL150-A | LL150T-A | LR150-A | LR150T-A |
| 2 | C200-A | — | — | — | LB200-A | LB200T-A | LL200-A | LL200T-A | LR200-A | LR200T-A |
| 2-1/2 | C250-A | — | — | — | LB250-A | — | LL250-A | — | LR250-A | — |
| 3 | C300-A | — | — | — | LB300-A | — | LL300-A | — | LR300-A | — |
| 3-1/2 | C350-A | — | — | — | LB350-A | — | LL350-A | — | LR350-A | — |
| 4 | C400-A | — | — | — | LB400-A | — | LL400-A | — | LR400-A | — |

| Hub Size (in.) | T | | TB | | X | |
|----------------|---------------|---------------|---------------|---------------|---------------|---------------|
| | Threaded Type | Setscrew Type | Threaded Type | Setscrew Type | Threaded Type | Setscrew Type |
| 1/2 | T50-A | T50T-A | TB50-A | — | X50-A | — |
| 3/4 | T75-A | T75T-A | TB75-A | — | X75-A | — |
| 1 | T100-A | T100T-A | TB100-A | — | X100-A | — |
| 1-1/4 | T125-A | — | TB125-A | — | — | — |
| 1-1/2 | T150-A | — | TB150-A | — | — | — |
| 2 | T200-A | — | TB200-A | — | — | — |
| 2-1/2 | T250-A | — | — | — | — | — |
| 3 | T300-A | — | — | — | — | — |
| 3-1/2 | T350-A | — | — | — | — | — |
| 4 | T400-A | — | — | — | — | — |

Typical Form 85 Conduit Bodies with Setscrews. For use with Electrical Metal Tubing (EMT).



Back Style for Form 85®







| Unilet Body | Flat Back | Round Back |
|------------------|----------------|--------------------|
| C, LB, LL, LR, T | 1/2" – 2" | 2-1/2" – 4" |
| TB | 1-1/4", 1-1/2" | 1/2", 3/4", 1", 2" |
| E, X | 1/2" – 1" | |

All setscrew types are flatback design.



Covers and Gaskets for Form 85™ Unilet® Conduit Outlet Bodies

Covers Furnished with Stainless Steel Fastening Screws.

Appleton Form 85™ Covers and Gaskets NOTE: Refer to page A-16 for Wiring Capacity Tables.

| Size | Blank Stamped Aluminum | Blank Cast Aluminum | Neoprene | Composition Fiber |
|-------------------------------|--|---|---|---|
| Form 85 Body Size (in.) |  Domed: 1/2" - 3" |  Flat: 1/2" - 2" |  Tear out inner perforated section to convert to "open type" gasket. |  |
| |  Flat: 3-1/2" - 4" |  Domed: 2-1/2" - 4" | | |
| 1/2 | K50-A | K50-CA | GK50-N | GK50-V |
| 3/4 | K75-A | K75-CA | GK75-N | GK75-V |
| 1 | K100-A | K100-CA | GK100-N | GK100-V |
| 1-1/4 | K125 & 150-A | K125 & 150-CA | GK125-150-N | GK125-150-V |
| 1-1/2 | K125 & 150-A | K125 & 150-CA | GK125-150-N | GK125-150-V |
| 2 | K200-A | K200-CA | GK200-N | GK200-V |
| 2-1/2 | K250 & 300-A | K250 & 300-CA | GK250-300-N | GK-250-300-V |
| 3 | K250 & 300-A | K250 & 300-CA | GK250-300-N | GK-250-300-V |
| 3-1/2 | K350 & 400-A | K350 & 400-CA | GK350-400-N | GK-350-400-V |
| 4 | K350 & 400-A | K350 & 400-CA | GK350-400-N | GK-350-400-V |

Wiring Device Covers

| | | |
|---|--|--|
|  |  |  |
| Lamp Receptacle with 1-1/2" Shade Holder Groove. Porcelain, 600 Watt, 600 Volt Rating | Device Cover for Interchangeable (Despard) Wiring Devices, Cast Aluminum with Mounting Strap | Switch Cover for Interchangeable (Despard) Devices, Cast Aluminum with Gasket and Steel Mounting Strap |
| Form 85 Body Size (in.) | Form 85 Body Size (in.) | Form 85 Body Size (in.) |
| Cat. No. | Cat. No. | Cat. No. |
| 1/2 | 1/2 | 3/4 |
| KLR50 | KWD50-A | KVS75-A |
| 3/4 | | |
| KLR75 | | |



A-10

Dimensions: Form 85™ Threaded and Setscrew, Unilet® Conduit Outlet Bodies, Aluminum

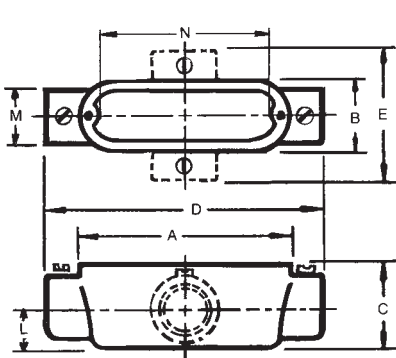

Types C, T, X

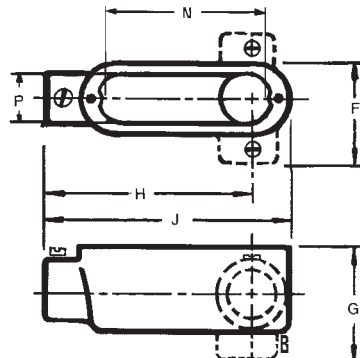

Types E, LB, LL, LR

Fraction/Decimal Equivalents (Inches)

| Fraction | Decimal |
|----------|---------|
| 1/16 | 0.06 |
| 1/8 | 0.13 |
| 3/16 | 0.19 |
| 1/4 | 0.25 |
| 5/16 | 0.31 |
| 3/8 | 0.38 |
| 7/16 | 0.44 |
| 1/2 | 0.50 |
| 9/16 | 0.56 |
| 5/8 | 0.63 |
| 11/16 | 0.69 |
| 3/4 | 0.75 |
| 13/16 | 0.81 |
| 7/8 | 0.88 |
| 15/16 | 0.94 |
| 1 | 1.00 |

Dimensions In Inches

| | Hub Trade Size (In.) | A | B | C | D | E | F | G | H | J | L | M | N | P |
|---------------|----------------------|-------|------|------|-------|------|------|------|-------|-------|------|------|-------|------|
| Pressure Cast | 1/2 | 3.94 | 1.31 | 1.38 | 4.75 | 2.56 | 2.00 | 2.06 | 3.50 | 4.31 | .63 | 1.13 | 3.14 | 1.05 |
| | 3/4 | 4.63 | 1.56 | 1.63 | 5.63 | 3.00 | 2.25 | 2.44 | 4.13 | 5.13 | .75 | 1.38 | 3.78 | 1.27 |
| | 1 | 5.38 | 1.81 | 1.88 | 6.69 | 3.50 | 2.63 | 2.81 | 4.88 | 6.00 | .94 | 1.69 | 4.50 | 1.52 |
| | 1-1/4 | 7.19 | 2.50 | 2.75 | 8.56 | | 3.50 | 3.88 | 6.56 | 7.88 | 1.06 | 2.13 | 6.00 | 2.25 |
| | 1-1/2 | 7.19 | 2.50 | 2.75 | 8.56 | | 3.50 | 3.81 | 6.44 | 7.88 | 1.19 | 2.38 | 6.00 | 2.25 |
| | 2 | 9.50 | 3.13 | 3.44 | 10.81 | | 4.19 | 4.56 | 8.31 | 10.19 | 1.50 | 2.94 | 8.06 | 2.75 |
| Sand Cast | 2-1/2 | 12.25 | 4.31 | 3.88 | 15.13 | 7.19 | 5.75 | 5.25 | 11.88 | 13.69 | 1.81 | 3.38 | 10.63 | 3.69 |
| | 3 | 12.25 | 4.31 | 4.63 | 15.13 | 7.19 | 5.75 | 6.00 | 11.56 | 13.69 | 2.19 | 4.13 | 10.63 | 3.69 |
| | 3-1/2 | 14.88 | 5.50 | 5.19 | 18.13 | 8.75 | 7.13 | 6.81 | 14.00 | 16.50 | 2.50 | 4.75 | 13.13 | 4.88 |
| | 4 | 14.88 | 5.50 | 5.56 | 18.13 | 8.75 | 7.13 | 7.19 | 13.75 | 16.50 | 2.75 | 5.13 | 13.13 | 4.88 |

Wiring Capacity: Form 85™ Conduit Bodies and Covers

Combine Body and Cover Capacities for Total usable Capacity per NEC 370-6(a)(1)

Form 85™ Aluminum Bodies and Covers: Threaded and Setscrew

| Capacity in Cubic Inches | | | | | | | | | | | |
|--------------------------|-------|------|-------|-------|-----|-------|----|------|------|---------------|------------|
| Hub Size (In.) | C | E | LB | LL LR | LRL | T | TA | TB | X | Stamped Cover | Cast Cover |
| 1/2 | 4.0 | 4.0 | 4.0 | 4.0 | — | 4.0 | — | 6.0 | 4.0 | 0.5 | 0 |
| 3/4 | 7.0 | 7.0 | 7.0 | 7.0 | — | 7.0 | — | 7.0 | 7.0 | 0.8 | 0.3 |
| 1 | 11.8 | 11.8 | 11.8 | 11.8 | — | 11.8 | — | 13.0 | 11.8 | 1.0 | 0.5 |
| 1-1/4 | 34.8 | — | 34.8 | 34.0 | — | 34.0 | — | 35.0 | — | 2.5 | 0.8 |
| 1-1/2 | 35.0 | — | 35.0 | 35.0 | — | 35.0 | — | 34.5 | — | 2.5 | 0.8 |
| 2 | 70.0 | — | 70.0 | 70.0 | — | 70.0 | — | 71.0 | — | 6.5 | 1.5 |
| 2-1/2 | 143.0 | — | 139.0 | 140.5 | — | 146.0 | — | — | — | 18.0 | 30.0 |
| 3 | 180.0 | — | 177.0 | 175.0 | — | 185.0 | — | — | — | 18.0 | 30.0 |
| 3-1/2 | 303.0 | — | 300.0 | 300.0 | — | 314.0 | — | — | — | — | 50.0 |
| 4 | 340.0 | — | 330.0 | 330.0 | — | 345.0 | — | — | — | — | 50.0 |



FM7™ Unilet® Conduit Outlet Bodies

For use with Rigid Steel, Rigid Aluminum, IMC, and EMT Conduit.

Applications

- Serve as pulling fittings.
- Make bends in conduit system.
- Provide openings for splicing.
- Connect and change direction of conduit runs.
- Allow connections for branch runs.
- Permit access to conductors for maintenance.

Features: Unilet® conduit outlet bodies

- Roomy interiors: more wiring space.
- Smooth, rounded integral bushings in hubs protect conductor insulation.
- Accurately tapped, tapered threads for tight, rigid joints and excellent ground continuity.

Features: FM7™ Series

- ① FM7 Grayloy™-Iron Unilets: most economical conduit bodies for use where the special advantages of malleable iron or aluminum are not required.
- ② FM7 Aluminum Unilets: same dimensions and design features as FM7 Grayloy™-Iron, plus light weight, high corrosion resistance.
- FM7 Wedge-Lok™ Formtite™ covers with integral gasket are approved for use in wet locations.
- Unique Wedge-Lok™ clip covers allow easy removal. No retapping of corroded body screw holes is necessary to replace cover.
- Completely interchangeable with Crouse-Hinds Form 7™ bodies, gaskets and covers. Equivalent FM7 and Form 7™ units have identical applications and installation dimensions.
- Flat back design provides greater cubic content for easier wire pulling and more room for splicing.
- Smooth hub bushings and cover openings protect conductor insulation. Smooth hub openings allow easy conduit joining.
- Pan-head cover screws secure cover clips and provide superior screwdriver seating and torque. Cover screws and clips are captive to prevent loss.
- Hub size, body style, and compliance data molded into body in large, easy-to-read form. Also maximum wire number/size and cubic capacity.

Standard Materials

- Grayloyiron or copper-free aluminum.
- Stamped steel, stamped aluminum, cast Grayloy-iron, and cast aluminum; cover screws: stainless steel.

Standard Finishes

- *Grayloy-iron bodies:* triplecoat– (1) zinc electroplate, (2) dichromate, and (3) epoxy powder coat.
- *Aluminum bodies:* epoxy powder coat.
- *Steel covers:* zinc electroplate.
- *Stamped aluminum covers:* natural finish.
- *Grayloy-iron covers:* triplecoat– (1) zinc electroplate, (2) dichromate, and (3) epoxy powder coat.
- *Cast aluminum covers:* epoxy powder coat.

Compliances

- UL Standard 514A.
- Federal Spec. W-C-586B.
- Suitable for classified location use in Class I, Division 2 areas, if installed in compliance with NEC 501-4(b).
- Appleton malleable iron products conform to ASTM A47-77, Grade 32510, which has the following properties: tensile strength, 50,000 psi; yield, 32,000 psi; and elongation, 10%.
- Appleton aluminum products are produced from a high strength copper-free (4/10 of 1% max.) alloy.
- Appleton Grayloy-iron products are a gray iron alloy with tensile strength similar to ASTM-A48 Class 30A (30,000 psi tensile), and with a Brinell hardness of approximately 180BH.

Product Cross Reference

- For explosionproof conduit outlet bodies and boxes, see Cat. Section J.



FM7



② FM7 Aluminum Conduit Body with Cast Aluminum Cover. 1" Type C shown.



① FM7 Grayloy™-iron, 1" Type C shown with cut-away body and cover to illustrate Wedge-Lok™ Clip Cover detail.

*Form 7 is a product of Crouse-Hinds, a member company of Cooper Industries.

FM7™ Grayloy™ – Iron and Aluminum Unilet® Conduit Bodies: Wedge-Lok™ Clip Covers

For use with Rigid Steel, Rigid Aluminum and IMC Conduit.

Interchangeable. Appleton FM7 bodies, covers and gaskets are completely interchangeable with equivalent Crouse-Hinds Form 7* bodies and covers. Applications and installation dimensions are also interchangeable.

No wire damage. Appleton FM7 bodies have a smooth, rounded, internal bushing in each hub and smooth cover openings to protect conductor insulation.

Easy cover removal. Unique FM7 Wedge-Lok Clip-Cover design allows easy removal at any later time, without damaging the conduit body. Because the cover is secured with clips— not screws — no retapping of corroded body screw holes is necessary to replace cover.

Positive-seating cover screws. Pan-head stainless steel cover screws, which hold the clips, provide superior screw-driver seating and torque for easier cover installation or removal. Each cover screw and its attached locking clip are held captive in the cover to prevent loss.

Full-line choice. Appleton FM7 bodies are offered in a complete range of hub configurations and sizes. FM7 covers are available in blank stamped steel or stamped aluminum, and also in cast Grayloy-iron or cast aluminum. Covers can be used without gaskets, or with a solid neoprene gasket. All Appleton FM7 bodies, covers and gaskets are interchangeable with Crouse-Hinds Form 7* bodies, covers and gaskets.

Approved for wet locations.

FM7 Grayloy-iron bodies with cast covers and gasket are approved for use in wet locations. (NEMA 3R)

Maximum corrosion protection. Appleton FM7 Grayloy-iron conduit bodies and cast covers have a triple-coat finish— (1) zinc electroplate, (2) dichromate, and (3) epoxy powder coating. FM7 aluminum bodies and cast covers are coated with epoxy powder coating. FM7 blank steel covers have a zinc electroplate finish. Superior FM7 finish gives greater corrosion protection in wet or harsh environments, assuring long, trouble-free service.

Grayloy-iron properties. Grayloy™ is an Appleton proprietary cast graphite flake gray iron alloy with superior physical and mechanical properties offering strength, hardness, fracture toughness, high vibration absorption and dimensional stability. Tensile strength is similar to ASTM-A48 Class 30A (30,000 tensile), with Brinell hardness of approximately 180BH.

Aluminum properties. Aluminum products are produced from a high strength copper-free (4/10 of 1% max.) alloy.

More wiring space. Appleton's FM7 flat-back design provides greater cubic content for easier wire pulling, and more room for splicing. FM7 flat back fits flush and snug against flat surfaces for more stable installation.

*Form 7 is a product of Crouse-Hinds, a member company of Cooper Industries.



Formtite™ 7 Features

- One-piece cover and gasket assembly
- Neoprene gasket is bonded to Iron, Steel or Aluminum cover
- Ease of installation
- Productivity gain
- Eliminates “stock outs” of one item or the other
- No need to order, store, handle, or install separate covers and gaskets because there are fewer SKU's to order and inventory



Appleton FM7™
Appleton FM7 (C57, 1-1/2")
28 Cubic Inches Capacity
Flat-Back Design



Crouse-Hinds Form 7
Crouse-Hinds Form 7 (C57, 1-1/2")
26 Cubic Inches Capacity

Appleton FM7:

- Maximum wire number/size and cubic capacity molded into body.
- Large size, style and compliance data molded into body.





Illustrated views are cut away to demonstrate back configurations.





FM7™ Grayloy™ - Iron and Aluminum Unilet® Conduit Bodies with Wedge-Lok™ Clip Covers and Gaskets

For use with Rigid Steel, Rigid Aluminum and IMC Conduit.

These Appleton FM7 conduit bodies, covers and gaskets have the same applications and installation dimensions as Crouse-Hinds Form 7 conduit bodies. Equivalent FM7 and Form 7 items are completely interchangeable.





Appleton FM7 Conduit Bodies NOTE: Refer to page A-15 for Wiring Capacity Tables

| Hub Size (in.) | C  | | LB  | | LL  | | LR  | | T  | |
|----------------|---|----------|--|----------|--|----------|---|----------|---|----------|
| | Grayloy-Iron | Aluminum | Grayloy-Iron | Aluminum | Grayloy-Iron | Aluminum | Grayloy-Iron | Aluminum | Grayloy-Iron | Aluminum |
| 1/2 | C17 | C17-SA | LB17 | LB17-SA | LL17 | LL17-SA | LR17 | LR17-SA | T17 | T17-SA |
| 3/4 | C27 | C27-SA | LB27 | LB27-SA | LL27 | LL27-SA | LR27 | LR27-SA | T27 | T27-SA |
| 1 | C37 | C37-SA | LB37 | LB37-SA | LL37 | LL37-SA | LR37 | LR37-SA | T37 | T37-SA |
| 1-1/4 | C47 | C47-SA | LB47 | LB47-SA | LL47 | LL47-SA | LR47 | LR47-SA | T47 | T47-SA |
| 1-1/2 | C57 | C57-SA | LB57 | LB57-SA | LL57 | LL57-SA | LR57 | LR57-SA | T57 | T57-SA |
| 2 | C67 | C67-SA | LB67 | LB67-SA | LL67 | LL67-SA | LR67 | LR67-SA | T67 | T67-SA |
| 2-1/2 | C77 | C77-SA | LB77 | LB77-SA | LL77 | LL77-SA | LR77 | LR77-SA | T77 | T77-SA |
| 3 | C87 | C87-SA | LB87 | LB87-SA | LL87 | LL87-SA | LR87 | LR87-SA | T87 | T87-SA |
| 3-1/2 | — | — | LB97 | LB97-SA | LL97 | LL97-SA | LR97 | LR97-SA | T97 | T97-SA |
| 4 | — | — | LB107 | LB107-SA | LL107 | LL107-SA | LR107 | LR107-SA | T107 | T107-SA |

| Hub Size (in.) | E  | | L*  | | TA  | | TB  | | X  | |
|----------------|---|----------|--|----------|--|----------|---|----------|---|----------|
| | Grayloy-Iron | Aluminum | Grayloy-Iron | Aluminum | Grayloy-Iron | Aluminum | Grayloy-Iron | Aluminum | Grayloy-Iron | Aluminum |
| 1/2 | E17 | E17-SA | L17 | — | TA17 | — | TB17 | TB17-SA | X17 | X17-SA |
| 3/4 | E27 | E27-SA | L27 | — | TA27 | — | TB27 | TB27-SA | X27 | X27-SA |
| 1 | E37 | E37-SA | L37 | — | TA37 | — | TB37 | TB37-SA | X37 | X37-SA |
| 1-1/4 | — | — | L47 | — | TA47 | — | TB47 | TB47-SA | X47 | X47-SA |
| 1-1/2 | — | — | L57 | — | TA57 | — | TB57 | TB57-SA | X57 | X57-SA |
| 2 | — | — | L67 | — | TA67 | — | TB67 | TB67-SA | X67 | X67-SA |

* L Unilets have double opening and are furnished with one steel cover, assembled.

Appleton FM7 Blank Covers and Gaskets (Covers furnished with Stainless Steel Screws)

| FM7 Body Size (in.) | Wedge-Lok Cast Cover  | | Formtite Cast Cover with Integral Gasket  | | Wedge-Lok Stamped Cover  | | Formtite Stamped Cover with Integral Gasket  | | Solid Neoprene Gasket  | |
|---------------------|---|----------|---|----------|--|----------|---|----------|--|--|
| | Grayloy-Iron | Aluminum | Grayloy-Iron | Aluminum | Steel | Aluminum | Steel | Aluminum | | |
| 1/2 | 170F | 170F-SA | 170FG | 170FG-SA | 170 | 170-SA | 170G | 170G-SA | GASK571 | |
| 3/4 | 270F | 270F-SA | 270FG | 270FG-SA | 270 | 270-SA | 270G | 270G-SA | GASK572 | |
| 1 | 370F | 370F-SA | 370FG | 370FG-SA | 370 | 370-SA | 370G | 370G-SA | GASK573 | |
| 1-1/4 | 470F | 470F-SA | 470FG | 470FG-SA | 470 | 470-SA | 470G | 470G-SA | GASK574 | |
| 1-1/2 | 570F | 570F-SA | 570FG | 570FG-SA | 570 | 570-SA | 570G | 570G-SA | GASK575 | |
| 2 | 670F | 670F-SA | 670FG | 670FG-SA | 670 | 670-SA | 670G | 670G-SA | GASK576 | |
| 2-1/2 | 870F | 870F-SA | 870FG | 870FG-SA | 870 | 870-SA | 870G | 870G-SA | GASK578 | |
| 3 | 870F | 870F-SA | 870FG | 870FG-SA | 870 | 870-SA | 870G | 870G-SA | GASK578 | |
| 3-1/2 | 970F | 970F-SA | 970FG | 970FG-SA | 970 | 970-SA | 970G | 970G-SA | GASK579 | |
| 4 | 970F | 970F-SA | 970FG | 970FG-SA | 970 | 970-SA | 970G | 970G-SA | GASK579 | |

Effective June, 2006
Copyright 2006



800-621-1506
www.appletonelec.com

FM7™ Conduit Body Dimensions

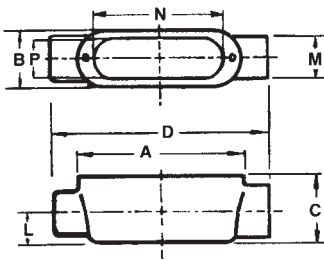

Type C

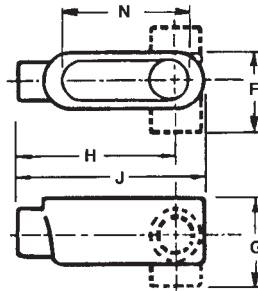

Types E, L, LB, LL, LR

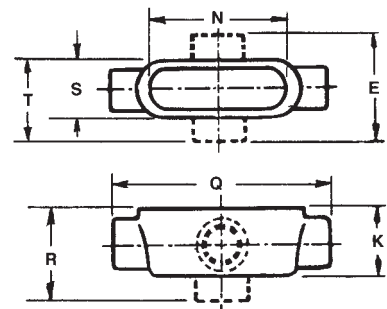

Types T, TA, TB, X

Dimensions in Inches

| Hub Size | A | B | C | D | E | F | G | H | J | K | L | M | N | P | Q | R | S | T |
|----------|-------|------|------|-------|------|------|------|-------|-------|------|------|------|-------|------|-------|------|------|------|
| 1/2 | 3.63 | 1.38 | 1.38 | 5.38 | 3.31 | 2.25 | 2.25 | 3.94 | 4.56 | 1.75 | 0.63 | 1.25 | 3.19 | 0.94 | 5.63 | 2.63 | 1.56 | 2.44 |
| 3/4 | 4.25 | 1.56 | 1.63 | 6.00 | 3.50 | 2.44 | 2.50 | 4.44 | 5.19 | 2.00 | 0.75 | 1.50 | 3.81 | 1.13 | 6.25 | 2.88 | 1.88 | 2.63 |
| 1 | 5.00 | 1.75 | 1.88 | 7.00 | 3.88 | 2.75 | 2.88 | 5.19 | 6.00 | 2.25 | 0.88 | 1.75 | 4.50 | 1.38 | 7.25 | 3.25 | 2.00 | 3.00 |
| 1-1/4 | 5.50 | 2.19 | 2.31 | 7.44 | 4.13 | 3.19 | 3.31 | 5.44 | 6.50 | 2.31 | 1.13 | 2.19 | 5.00 | 1.75 | 7.44 | 3.31 | 2.19 | 3.19 |
| 1-1/2 | 6.00 | 2.44 | 2.56 | 8.19 | 4.63 | 3.50 | 3.69 | 5.94 | 7.13 | 2.56 | 1.25 | 2.44 | 5.44 | 1.94 | 8.19 | 3.63 | 2.44 | 3.56 |
| 2 | 7.00 | 3.00 | 3.13 | 9.19 | 5.19 | 4.06 | 4.25 | 6.63 | 8.13 | 3.13 | 1.50 | 3.00 | 6.38 | 2.44 | 9.19 | 4.19 | 3.00 | 4.13 |
| 2-1/2 | 9.00 | 4.25 | 3.63 | 12.00 | — | 5.75 | 5.13 | 8.75 | 10.50 | 3.63 | 1.75 | 3.50 | 8.38 | 3.56 | 12.00 | — | 4.25 | 5.75 |
| 3 | 9.00 | 4.25 | 4.38 | 12.00 | — | 5.75 | 5.88 | 8.38 | 10.50 | 4.38 | 2.13 | 4.25 | 8.38 | 3.56 | 12.06 | — | 4.25 | 5.75 |
| 3-1/2 | 11.00 | 5.25 | 4.88 | — | — | 6.94 | 6.56 | 10.25 | 12.69 | 4.88 | 2.38 | 4.75 | 10.25 | 4.50 | 14.31 | — | 5.25 | 6.94 |
| 4 | 11.00 | 5.25 | 5.38 | — | — | 6.94 | 7.06 | 10.00 | 12.69 | 5.38 | 2.63 | 5.25 | 10.25 | 4.50 | 14.31 | — | 5.25 | 6.94 |

Fraction/Decimal Equivalents (Inches)

| Fraction | Decimal | Fraction | Decimal | Fraction | Decimal | Fraction | Decimal |
|----------|---------|----------|---------|----------|---------|----------|---------|
| 1/16 | 0.06 | 5/16 | 0.31 | 9/16 | 0.56 | 13/16 | 0.81 |
| 1/8 | 0.13 | 3/8 | 0.38 | 5/8 | 0.63 | 7/8 | 0.88 |
| 3/16 | 0.19 | 7/16 | 0.44 | 11/16 | 0.69 | 15/16 | 0.94 |
| 1/4 | 0.25 | 1/2 | 0.50 | 3/4 | 0.75 | 1 | 1.00 |

A-16

Wiring Capacity: FM7™ Conduit Bodies and Covers

Combine Body and Cover Capacities for Total usable Capacity per NEC 370-6(a)(1)

FM7™ Grayloy™ -Iron Bodies and Covers: Threaded

| Capacity in Cubic Inches | | | | | | | | | | | |
|--------------------------|-------|------|-------|-------|------|-------|------|------|------|---------------|------------|
| Hub Size (In.) | C | E | LB | LL LR | L | T | TA | TB | X | Stamped Cover | Cast Cover |
| 1/2 | 4.0 | 4.0 | 4.0 | 4.0 | 5.0 | 6.0 | 6.0 | 6.0 | 6.0 | 0.3 | 0.4 |
| 3/4 | 7.0 | 7.0 | 7.0 | 7.0 | 9.0 | 10.0 | 10.0 | 10.0 | 10.0 | 0.5 | 0.8 |
| 1 | 11.0 | 11.0 | 11.0 | 11.0 | 13.5 | 15.5 | 15.5 | 15.5 | 15.5 | 1.3 | 1.3 |
| 1-1/4 | 20.0 | — | 20.0 | 20.0 | 22.5 | 20.0 | 20.0 | 20.0 | 20.0 | 1.8 | 2.0 |
| 1-1/2 | 28.0 | — | 28.0 | 28.0 | 31.0 | 28.0 | 28.0 | 28.0 | 28.0 | 2.3 | 3.0 |
| 2 | 50.0 | — | 50.0 | 50.0 | 55.0 | 50.0 | 50.0 | 50.0 | 50.0 | 2.8 | 4.8 |
| 2-1/2 | 102.0 | — | 102.0 | 102.0 | — | 102.0 | — | — | — | 9.8 | 9.7 |
| 3 | 133.0 | — | 133.0 | 133.0 | — | 133.0 | — | — | — | 9.8 | 9.7 |
| 3-1/2 | — | — | 218.0 | 218.0 | — | 218.0 | — | — | — | 16.5 | 16.0 |
| 4 | — | — | 244.0 | 244.0 | — | 244.0 | — | — | — | 16.5 | 16.0 |

FM7™ Aluminum Bodies and Covers: Threaded

| Capacity in Cubic Inches | | | | | | | | | | | |
|--------------------------|-------|------|-------|-------|---|-------|----|------|------|---------------|------------|
| Hub Size (In.) | C | E | LB | LL LR | L | T | TA | TB | X | Stamped Cover | Cast Cover |
| 1/2 | 4.0 | 4.0 | 4.0 | 4.0 | — | 6.0 | — | 6.0 | 6.0 | 0.3 | 0.4 |
| 3/4 | 7.0 | 7.0 | 7.0 | 7.0 | — | 10.0 | — | 10.0 | 10.0 | 0.5 | 0.8 |
| 1 | 11.0 | 11.0 | 11.0 | 11.0 | — | 15.5 | — | 15.5 | 15.5 | 1.3 | 1.3 |
| 1-1/4 | 20.0 | — | 20.0 | 20.0 | — | 20.0 | — | 20.0 | 20.0 | 1.8 | 2.0 |
| 1-1/2 | 28.0 | — | 28.0 | 28.0 | — | 28.0 | — | 28.0 | 28.0 | 2.3 | 3.0 |
| 2 | 50.0 | — | 50.0 | 50.0 | — | 50.0 | — | 50.0 | 50.0 | 2.8 | 4.8 |
| 2-1/2 | 102.0 | — | 102.0 | 102.0 | — | 102.0 | — | — | — | 9.8 | 9.7 |
| 3 | 133.0 | — | 133.0 | 133.0 | — | 133.0 | — | — | — | 9.8 | 9.7 |
| 3-1/2 | — | — | 218.0 | 218.0 | — | 218.0 | — | — | — | 16.5 | 16.0 |
| 4 | — | — | 244.0 | 244.0 | — | 244.0 | — | — | — | 16.5 | 16.0 |

FM8® Unilet® Conduit Outlet Bodies

For use with Rigid Steel, Rigid Aluminum, IMC, and EMT Conduit.

Applications

- Serve as pulling fittings.
- Make bends in conduit system.
- Provide openings for splicing.
- Connect and change direction of conduit runs.
- Allow connections for branch runs.
- Permit access to conductors for maintenance.

Features: Unilet® conduit outlet bodies

- Roomy interiors: more wiring space.
- Smooth, rounded integral bushings in hubs protect conductor insulation.
- Accurately tapped, tapered threads for tight, rigid joints and excellent ground continuity.

Features: FM8® Series

- Completely interchangeable with Crouse-Hinds Form 8™ bodies, gaskets and covers. Equivalent FM8 and Form 8* units have identical applications and installation dimensions.
- Flat back design provides greater cubic content for easier wire pulling and more room for splicing.
- FM8 Grayloy™-iron with "FG" Series cast covers and gaskets are approved for use in wet locations.
- Stainless steel screws on stamped and cast covers.
- Smooth hub bushings and cover openings protect conductor insulation. Smooth hub openings allow easy conduit joining.

Standard Materials

- *Unilet conduit bodies:* Grayloyiron.
- *Covers:* cast Grayloy-iron, stamped steel; cover screws: stainless steel.
- *Gaskets:* neoprene.

Standard Finishes

- *Grayloy-iron bodies:* triplecoat– (1) zinc electroplate, (2) dichromate, and (3) epoxy powder coat.
- *FM8 steel covers:* zinc electroplate.
- *FM8 Grayloy-iron covers:* triplecoat– (1) zinc electroplate, (2) dichromate, and (3) epoxy powder coat.

Compliances

- UL Standard 514A.
- Federal Spec. W-C-586B.

- Suitable for classified location use in Class I, Division 2 areas, if installed in compliance with NEC 501-4(b).
- Appleton malleable iron products conform to ASTM A47-77, Grade 32510, which has the following properties: tensile strength, 50,000 psi; yield, 32,000 psi; and elongation, 10%.
- Appleton aluminum products are produced from a high strength copper-free (4/10 of 1% max.) alloy.
- Appleton Grayloy-iron products are a gray iron alloy with tensile strength similar to ASTM-A48 Class 30A (30,000 psi tensile), and with a Brinell hardness of approximately 180BH.

Product Cross Reference

- For explosionproof conduit outlet bodies and boxes, see Cat. Section J.
- For Mogul Unilets®, see pages A-17 through A-24.

Freedom of Choice. With new FM8 series added to Appleton's full-line family of conduit bodies, you have a single source for the right choice needed for every job— FM8 Grayloy-iron bodies and covers, FM7 Grayloy-iron or aluminum threaded bodies and covers... malleable iron Form 35... aluminum Form 85... and malleable iron or aluminum NEC Mogul 6x8x.

Interchangeable. Appleton FM8 bodies, covers and gaskets are completely interchangeable with equivalent Crouse-Hinds Form 8* bodies and covers. Applications and installation dimensions are also interchangeable.

No wire damage. Appleton FM8 bodies have a smooth, rounded, internal bushing in each hub and smooth cover openings to protect conductor insulation.

Full-line choice. Appleton FM8 bodies are offered in a complete range of hub configurations and sizes. FM8 covers are available in Grayloy-iron. Covers can be used without gaskets, or with a solid neoprene gasket. All Appleton FM8 bodies, covers and gaskets are interchangeable with Crouse-Hinds Form 8* bodies, covers and gaskets.

Approved for wet locations. FM8 Grayloy-iron bodies with cast covers and gasket are approved for use in wet locations. (NEMA 3R)



FM8



FM8 Grayloy™-iron Conduit Body with cast cover. 1" Type C shown.

*Form 8 is a product of Crouse-Hinds, a member company of Cooper Industries.

Maximum corrosion protection. Appleton FM8 Grayloy-iron conduit bodies and cast covers have a triple-coat finish— (1) zinc electroplate, (2) dichromate, and (3) epoxy powder coating. FM8 blank steel covers have a zinc electroplate finish. Superior FM8 finish gives greater corrosion protection in wet or harsh environments, assuring long, trouble-free service.

Grayloy-iron properties. Grayloy™ is an Appleton proprietary cast graphite flake gray iron alloy with superior physical and mechanical properties offering strength, hardness, fracture toughness, high vibration absorption and dimensional stability. Tensile strength is similar to ASTM-A48 Class 30A (30,000 tensile), with Brinell hardness of approximately 180BH.

Aluminum properties. Aluminum products are produced from a high strength copper-free (4/10 of 1% max.) alloy.

More wiring space. Appleton's FM8 flat-back design provides greater cubic content for easier wire pulling, and more room for splicing. FM8 flat back fits flush and snug against flat surfaces for more stable installation.



A-18



FM8® Grayloy™ -Iron Unilet® Conduit Bodies with Covers and Gaskets

For use with Rigid Steel and IMC Conduit.

These Appleton FM8 conduit bodies, covers and gaskets have the same applications and installation dimensions as Crouse-Hinds Form 8 conduit bodies. Equivalent FM8 and Form 8 items are interchangeable.

Appleton FM8® Conduit Bodies NOTE: Refer to page A-15 for Wiring Capacity Table

| | C  Grayloy-Iron | LB  Grayloy-Iron | LL  Grayloy-Iron | LR  Grayloy-Iron |
|----------------|---|--|---|--|
| Hub Size (in.) | | | | |
| 1/2 | C18 | LB18 | LL18 | LR18 |
| 3/4 | C28 | LB28 | LL28 | LR28 |
| 1 | C38 | LB38 | LL38 | LR38 |
| 1-1/4 | C448 | LB448 | LL448 | LR448 |
| 1-1/2 | C58 | LB58 | LL58 | LR58 |
| 2 | C68 | LB68 | LL68 | LR68 |
| 2-1/2 | C78 | LB78 | LL78 | LR78 |
| 3 | C88 | LB888 | LL888 | LR888 |
| 3-1/2 | — | LB98 | — | — |
| 4 | — | LB108 | — | — |

| | T  Grayloy-Iron | TB  Grayloy-Iron | X  Grayloy-Iron | |
|----------------|---|--|--|--|
| Hub Size (in.) | | | | |
| 1/2 | T18 | TB18 | X18 | |
| 3/4 | T28 | TB28 | X28 | |
| 1 | T38 | TB38 | X38 | |
| 1-1/4 | T448 | TB448 | X448 | |
| 1-1/2 | T58 | TB58 | X58 | |
| 2 | T68 | TB68 | X68 | |
| 2-1/2 | T78 | — | — | |
| 3 | T88 | — | — | |

Appleton FM8® Blank Covers and Gaskets (Covers furnished with stainless steel screws, 1-1/2"–4" covers provided with 4 screws)

| | Stamped Cover Steel | Cast Cover Grayloy-Iron | Solid Gasket Neoprene | Open Gasket Neoprene |
|---------------------|---|---|--|---|
| FM8 Body Size (in.) |  |  |  |  |
| 1/2 | 180 | 180F | GASK851N | — |
| 3/4 | 280 | 280F | GASK852N | — |
| 1 | 380 | 380F | GASK853N | — |
| 1-1/4 | 480 | 480F | GASK854N | — |
| 1-1/2 | 580 | 580F | — | GASK805N |
| 2 | 680 | 680F | — | GASK806N |
| 2-1/2 | 880 | 880F | — | GASK808N |
| 3 | 880 | 880F | — | GASK808N |
| 3-1/2 | 980 | 980F | — | GASK809N |
| 4 | 980 | 980F | — | GASK809N |

Effective September, 2005
Copyright 2005



800-621-1506
www.appletonelec.com

FM8® Conduit Body Dimensions

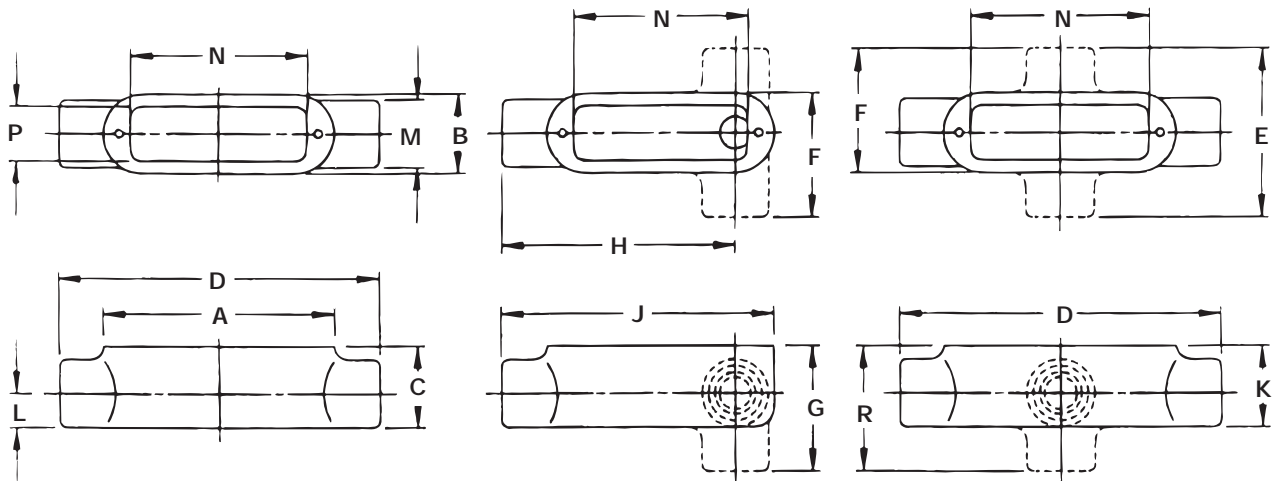

TYPE C

TYPES E, LB, LL, LR

TYPES T, TB, X

Dimensions In Inches

| Hub Size | A | B | C | D | E | F | G | H | J | K | L | M | N | P | R |
|----------|-------|------|------|-------|------|------|------|-------|-------|------|------|------|-------|------|------|
| 1/2 | 4.22 | 1.47 | 1.47 | 5.94 | 3.13 | 2.31 | 2.28 | 4.38 | 5.09 | 1.78 | 0.63 | 1.25 | 3.28 | 1.00 | 2.59 |
| 3/4 | 4.81 | 1.66 | 1.69 | 6.56 | 3.31 | 2.50 | 2.50 | 4.91 | 5.75 | 2.00 | 0.75 | 1.50 | 3.94 | 1.19 | 2.81 |
| 1 | 5.59 | 1.84 | 1.97 | 7.56 | 3.72 | 2.78 | 2.91 | 5.72 | 6.63 | 2.28 | 0.88 | 1.75 | 4.53 | 1.38 | 3.22 |
| 1-1/4 | 6.56 | 2.19 | 2.38 | 8.44 | 4.06 | 3.13 | 3.31 | 6.41 | 7.50 | 2.63 | 1.09 | 2.19 | 5.31 | 1.75 | 3.56 |
| 1-1/2 | 7.88 | 2.78 | 2.78 | 10.38 | 5.28 | 4.03 | 4.03 | 7.75 | 9.13 | 2.78 | 1.38 | 2.44 | 6.50 | 2.09 | 4.03 |
| 2 | 9.75 | 3.88 | 3.56 | 12.38 | 6.38 | 5.13 | 4.81 | 9.19 | 11.13 | 3.56 | 1.88 | 3.00 | 8.63 | 3.00 | 4.81 |
| 2-1/2 | 12.25 | 5.00 | 4.44 | 15.63 | — | 6.69 | 6.13 | 11.44 | 13.94 | 4.44 | 2.50 | 3.50 | 10.88 | 4.25 | — |
| 3 | 12.25 | 5.00 | 4.81 | 15.63 | — | 6.69 | 6.50 | 11.44 | 13.94 | 4.81 | 2.50 | 4.25 | 10.88 | 4.25 | — |
| 3-1/2 | 15.00 | 6.25 | 5.69 | — | — | — | 7.56 | 13.75 | 16.88 | — | 3.13 | 4.75 | 13.44 | 5.44 | — |
| 4 | 15.00 | 6.25 | 5.94 | — | — | — | 7.81 | 13.75 | 16.88 | — | 3.13 | 5.25 | 13.44 | 5.44 | — |

Fraction/Decimal Equivalents (Inches)

| Fraction | Decimal | Fraction | Decimal | Fraction | Decimal | Fraction | Decimal |
|----------|---------|----------|---------|----------|---------|----------|---------|
| 1/32 | 0.03 | 9/32 | 0.28 | 17/32 | 0.53 | 25/32 | 0.78 |
| 1/16 | 0.06 | 5/16 | 0.31 | 9/16 | 0.56 | 13/16 | 0.81 |
| 3/32 | 0.09 | 11/32 | 0.34 | 19/32 | 0.59 | 27/32 | 0.84 |
| 1/8 | 0.13 | 3/8 | 0.38 | 5/8 | 0.63 | 7/8 | 0.88 |
| 5/32 | 0.16 | 13/32 | 0.41 | 21/32 | 0.66 | 29/32 | 0.91 |
| 3/16 | 0.31 | 7/16 | 0.44 | 11/16 | 0.69 | 15/16 | 0.94 |
| 7/32 | 0.22 | 15/32 | 0.47 | 23/32 | 0.72 | 31/32 | 0.97 |
| 1/4 | 0.25 | 1/2 | 0.50 | 3/4 | 0.75 | 1 | 1.00 |

Wiring Capacity: FM8® Conduit Bodies and Covers

Combine Body and Cover Capacities for Total usable Capacity
per NEC 370-6(a)(1)

FM8® Grayloy™ -Iron Bodies and Covers: Threaded

Capacity in Cubic Inches

| Hub Size (In.) | C | E | LB | LL LR | L | T | TA | TB | X | Stamped Cover | Cast Cover |
|----------------|-------|---|-------|-------|---|-------|----|-------|-------|---------------|------------|
| 1/2 | 5.0 | — | 5.0 | 5.0 | — | 6.0 | — | 6.0 | 6.0 | 0.5 | 0.3 |
| 3/4 | 8.0 | — | 8.0 | 8.0 | — | 10.0 | — | 10.0 | 10.0 | 0.8 | 0.8 |
| 1 | 13.0 | — | 13.0 | 13.0 | — | 15.0 | — | 15.0 | 15.0 | 1.0 | 1.0 |
| 1-1/4 | 24.0 | — | 24.0 | 24.0 | — | 25.0 | — | 25.0 | 25.0 | 1.5 | 1.5 |
| 1-1/2 | 42.5 | — | 42.5 | 42.5 | — | 44.0 | — | 44.0 | 44.0 | 1.8 | 7.5 |
| 2 | 105.0 | — | 105.0 | 105.0 | — | 105.0 | — | 105.0 | 105.0 | 4.5 | 12.5 |
| 2-1/2 | 200.0 | — | 200.0 | 200.0 | — | 200.0 | — | — | — | 12.3 | 34.5 |
| 3 | 217.0 | — | 217.0 | 217.0 | — | 217.0 | — | — | — | 12.3 | 34.5 |
| 3-1/2 | — | — | 380.0 | — | — | — | — | — | — | 24.0 | 65.3 |
| 4 | — | — | 400.0 | — | — | — | — | — | — | 24.0 | 65.3 |

FM9™ Aluminum Unilet® Conduit Outlet Bodies, Covers and Gaskets

For use with Rigid Steel, Rigid Aluminum and IMC.

Applications

- Serve as pulling fittings.
- Make bends in conduit system.
- Provide openings for splicing.
- Connect and change direction of conduit runs.
- Allow connections for branch runs.
- Permit access to conductors for maintenance.

Features: FM9 Unilet® conduit outlet bodies

- Roomy interiors: deep body cavity provides increased volume allowing higher wiring capacity.
- Smooth, rounded integral bushings in hubs protect conductor insulation.
- Accurately tapped, tapered threads for tight, rigid joints and excellent ground continuity.
- Completely interchangeable with Crouse-Hinds Mark9™ bodies, gaskets and covers. Equivalent FM9 and Mark 9™ units have identical applications and installation dimensions.
- Seven body styles available in 1/2" to 4" sizes, TB's in 1/2" to 2" and X's in 1/2" to 1".

Features:

- Aluminum Unilets: produced from a high-strength copper-free (4/10 of 1% max.) alloy, for light weight and high corrosion resistance.
- FM9™ Formtite™ 9 covers with integral gasket are approved for use in wet locations.
- Covers are domed for extra wiring space.
- Smooth hub bushings and cover openings protect conductor insulation. Smooth hub openings allow easy conduit joining.
- Stainless steel pan-head cover screws secure cover to body and provide superior screwdriver seating and torque. Cover screws are captive to prevent loss in sizes 1/2" to 2".
- Hub size, body style, and compliance data molded into body in large, easy-to-read form. Also maximum wire number/size and cubic capacity.



LL Body with Formtite™ 9 Integral Gasket Cover

Captive Stainless Steel Pan-Head Cover Screws



Standard Materials

- Conduit bodies: copper-free aluminum.
- Covers: stamped copper-free aluminum
- Cover screws: stainless steel.
- Gaskets: Neoprene

Standard Finishes

- Conduit bodies, covers and screws: natural

Compliances

- UL Standard 514A.





A-22

FM9™ Aluminum Unilet® Conduit Bodies, Covers and Gaskets

For use with Rigid Steel, Rigid Aluminum and IMC Conduit.

Appleton FM9 Conduit Bodies NOTE: Refer to page A-23 for Wiring Capacity Tables

| | C  | LB  | LL  | LR  |
|----------------|---|--|--|--|
| Hub Size (in.) | | | | |
| 1/2 | C19 | LB19 | LL19 | LR19 |
| 3/4 | C29 | LB29 | LL29 | LR29 |
| 1 | C39 | LB39 | LL39 | LR39 |
| 1-1/4 | C49 | LB49 | LL49 | LR49 |
| 1-1/2 | C59 | LB59 | LL59 | LR59 |
| 2 | C69 | LB69 | LL69 | LR69 |
| 2-1/2 | C789 | LB789 | LL789 | LR789 |
| 3 | C889 | LB889 | LL889 | LR889 |
| 3-1/2 | C989 | LB989 | LL989 | LR989 |
| 4 | C1089 | LB1089 | LL1089 | LR1089 |
| | T  | TB  | X  | |
| Hub Size (in.) | | | | |
| 1/2 | T19 | TB19 | X19 | |
| 3/4 | T29 | TB29 | X29 | |
| 1 | T39 | TB39 | X39 | |
| 1-1/4 | T49 | TB49 | — | |
| 1-1/2 | T59 | TB59 | — | |
| 2 | T69 | TB69 | — | |
| 2-1/2 | T789 | — | — | |
| 3 | T889 | — | — | |
| 3-1/2 | T989 | — | — | |
| 4 | T1089 | — | — | |

Appleton FM9 Blank Covers and Gaskets and Formtite™ 9 Stamped Aluminum Cover with Integral Gasket (Covers furnished with Stainless Steel Screws)

| | Stamped Aluminum Cover  | Solid Gasket Neoprene  | Formtite™ 9  |
|---------------------|---|--|---|
| FM9 Body Size (in.) | | | |
| 1/2 | 190 | GASK1941 | 190G |
| 3/4 | 290 | GASK1942 | 290G |
| 1 | 390 | GASK1943 | 390G |
| 1-1/4 | 490 | GASK1944 | 490G |
| 1-1/2 | 590 | GASK1945 | 590G |
| 2 | 690 | GASK1946 | 690G |
| 2-1/2 | 889 | GASK808N | 889G |
| 3 | 889 | GASK808N | 889G |
| 3-1/2 | 989 | GASK809N | 989G |
| 4 | 989 | GASK809N | 989G |

FM9™ Conduit Body Dimensions

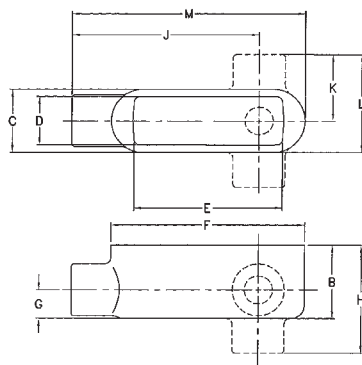

Type LB, LL & LR

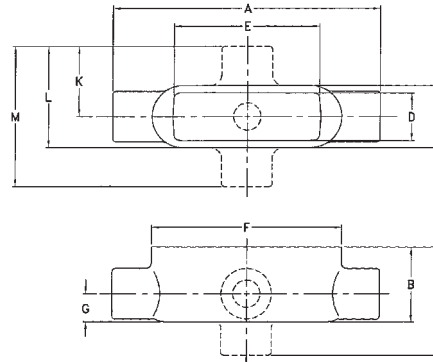

Type C, T, TB & X

Dimensions in Inches

| | Hub Size | A | B | C | D | E | F | G | H | J | K | L | M | N |
|--------------------|----------|-------|------|------|-------|-------|-------|------|-------|-------|------|------|-------|-------|
| C, LB, T, LL, & LR | 1/2 | 4.97 | 1.56 | 1.38 | 1.06 | 3.28 | 4.22 | 0.63 | 2.31 | 3.59 | 1.44 | 2.13 | — | 4.59 |
| | 3/4 | 5.69 | 1.81 | 1.56 | 1.22 | 3.94 | 4.81 | 0.75 | 2.59 | 4.09 | 1.59 | 2.38 | — | 2.52 |
| | 1 | 6.59 | 2.06 | 1.75 | 1.41 | 4.56 | 5.59 | 0.88 | 3.03 | 4.84 | 1.84 | 2.72 | — | 6.09 |
| | 1-1/4 | 7.63 | 2.69 | 2.19 | 1.88 | 5.25 | 6.56 | 1.09 | 3.75 | 5.38 | 2.16 | 3.25 | — | 7.09 |
| | 1-1/2 | 8.25 | 3.03 | 2.53 | 2.19 | 5.94 | 7.25 | 1.25 | 4.03 | 6.00 | 2.25 | 3.53 | — | 7.81 |
| | 2 | 10.69 | 3.75 | 3.19 | 2.81 | 8.06 | 9.56 | 1.50 | 4.88 | 7.88 | 2.66 | 4.25 | — | 10.13 |
| | 2-1/2 | 15.63 | 4.94 | 5.00 | 4.25 | 10.88 | 12.25 | 2.50 | 6.63 | 11.44 | 4.19 | 6.69 | — | 13.94 |
| | 3 | 15.63 | 5.31 | 5.00 | 4.25 | 10.88 | 12.25 | 2.50 | 7.00 | 11.44 | 4.19 | 6.69 | — | 13.94 |
| | 3-1/2 | 18.75 | 6.19 | 6.25 | 5.44 | 13.44 | 15.00 | 3.13 | 8.06 | 13.75 | 5.00 | 8.13 | — | 16.88 |
| 4 | 18.75 | 6.44 | 6.25 | 5.44 | 13.44 | 15.00 | 3.13 | 8.31 | 13.75 | 5.00 | 8.13 | — | 16.88 | |
| TB & X | 1/2 | 5.94 | 1.94 | 1.38 | 1.03 | 3.28 | 4.22 | 0.63 | 2.75 | — | 1.56 | 2.25 | 3.13 | 5.06 |
| | 3/4 | 6.56 | 2.22 | 1.56 | 1.22 | 3.94 | 4.81 | 0.75 | 3.03 | — | 1.66 | 2.44 | 3.31 | 5.69 |
| | 1 | 7.50 | 2.44 | 1.75 | 1.38 | 4.56 | 5.59 | 0.88 | 3.38 | — | 1.84 | 2.72 | 3.69 | 6.53 |
| | 1-1/4 | 8.50 | 2.69 | 2.19 | 1.75 | 5.25 | 6.56 | 1.09 | 3.75 | — | — | — | — | 7.53 |
| | 1-1/2 | 8.25 | 3.03 | 2.53 | 2.19 | 5.94 | 7.25 | 1.25 | 4.03 | — | — | — | — | 7.81 |
| | 2 | 10.69 | 3.75 | 3.19 | 2.75 | 8.06 | 9.56 | 1.50 | 4.88 | — | — | — | — | 10.13 |

Wiring Capacity in Cubic Inches

| Hub Size | C | LB | LL / LR | T | TB | X | Cover |
|----------|-------|-------|---------|-------|------|------|-------|
| 1/2 | 4.8 | 5.0 | 5.3 | 5.0 | 6.8 | 7.3 | 0.5 |
| 3/4 | 7.8 | 8.3 | 8.5 | 8.3 | 11.0 | 11.3 | 0.8 |
| 1 | 12.3 | 12.8 | 13.3 | 12.5 | 16.5 | 17.0 | 1.0 |
| 1-1/4 | 25.3 | 26.5 | 27.3 | 26.3 | 25.8 | | 1.5 |
| 1-1/2 | 37.5 | 39.0 | 39.8 | 38.5 | 36.5 | | 2.5 |
| 2 | 77.5 | 81.3 | 82.8 | 79.5 | 77.0 | | 6.5 |
| 2-1/2 | 230.0 | 230.0 | 230.0 | 230.0 | | | 12.3 |
| 3 | 250.0 | 250.0 | 250.0 | 250.0 | | | 12.3 |
| 3-1/2 | 450.0 | 450.0 | 450.0 | 450.0 | | | 24.0 |
| 4 | 470.0 | 470.0 | 470.0 | 470.0 | | | 24.0 |

Fraction/Decimal Equivalents (Inches)

| Fraction | Decimal | Fraction | Decimal |
|----------|---------|----------|---------|
| 1/16 | 0.06 | 9/16 | 0.56 |
| 1/8 | 0.13 | 5/8 | 0.63 |
| 3/16 | 0.19 | 11/16 | 0.69 |
| 1/4 | 0.25 | 3/4 | 0.75 |
| 5/16 | 0.31 | 13/16 | 0.81 |
| 3/8 | 0.38 | 7/8 | 0.88 |
| 7/16 | 0.44 | 15/16 | 0.94 |
| 1/2 | 0.50 | 1 | 1.00 |

Mogul Unilet® Conduit Outlet Bodies: NEC 6x8x Series (C, LB and UB) and Types LL, LR and T

For use with Threaded Rigid Metal Conduit and IMC.
Complete with Assembled Cover and Neoprene Gasket.

Applications

- Larger body size facilitates pulling of large and heavy conductors. Specially designed raised cast covers provide additional wiring area.
- Mogul Unilets® for pulling straight, 45° or 90° angle turns and/or making taps and splices.

Features

- LB and UB Moguls

Length Requirement: distance between centerline of each hub bushing (conduit stop) exceeds six times the trade diameter of the conduit per NEC 314-28(a)(2).

Bending Space Requirement: these moguls also meet the NEC 314-28(a)(2) Exception requirement spelled out in NEC 312-6(a) Table.

- C Moguls

Length Requirement: distance between centerline of each hub bushing (conduit stop) exceeds eight times the trade diameter of the conduit per NEC 314-28(a)(1).

Bending Space Requirement: not applicable.

- *LL and LR Moguls:* Like LB moguls, these moguls have an end hub. However, the second hub is in the side (LL left and LR right) instead of the back.*

- *T Moguls:* These are like "C" moguls (1" thru 4"), except with an additional middle side hub. Distance between the centerline of each "C" hub conduit stop exceeds eight times the trade diameter of the conduit per NEC 314-28(a)(1).*

- Exclusive built-in rollers facilitate cable pulling. Available on NEC 6x8x Series Moguls (C, LB and UB) in sizes 1-1/4" and up.

- Smooth, rounded integral bushing in each hub protects conductor insulation.
- Accurately tapped, tapered threads for tight, rigid joints and ground continuity.
- Covers have captive stainless steel screws to speed installation, prevent "freezing" of screws.

*If less than maximum conductors permitted by NEC are used, smaller wires may be used additionally through "LL", "LR" or "T" hubs. If large conductors are required to be bent in "LL", "LR" or "T" direction, order junction boxes instead from Cat. Sec. C.

NEC 6x8x SERIES MOGULS



C Type NEC 8x



LB Type 1" - 2" NEC 6x



LB Type 2-1/2" - 4" NEC 6x



UB Type NEC 6x

LL, LR AND T MOGULS



LR Type NEC 6x



LL Type NEC 6x



T Type NEC 8x

Standard Materials

- Malleable iron or aluminum.
- Gaskets: Neoprene.

Standard Finishes

- *Malleable iron bodies and covers:* triple-coat — (1) zinc electroplate, (2) dichromate and (3) epoxy powder coat.
- *Aluminum bodies and covers:* epoxy powder coat.

Compliances

- UL Standard 514A.
- NEC 6x8x Series moguls comply with NEC 314-28(a)-1-2.
- Federal Spec. W-C-586B.
- Suitable for classified location use in Class I, Div. 2 areas, if installed in compliance with NEC 501-4(b).

- Appleton malleable iron products conform to ASTM A47-77, Grade 32510, which has the following properties: tensile strength, 50,000 psi; yield, 32,000 psi; and elongation, 10%.

- Appleton aluminum products are produced from a high strength copper-free (4/10 of 1% max.) alloy.



Patented rollers make cable-pulling easier, eliminate insulation damage.

NEC 6x8x Series (C, LB and UB) and Types LL, LR and T Mogul Unilet® Malleable Iron or Aluminum

For use with Threaded Rigid Metal Conduit and IMC.
Furnished with Assembled Cast Cover and Neoprene Gasket.

NOTE: Refer to page A-24 for Wiring Capacity Tables.

| | Type | Hub Size (In.) | Body, Cover & Gasket | | Gasket Only | Cover & Gasket | | |
|--|--|---------------------------|---------------------------|-----------|-------------|----------------|-----------|-----------|
| | | | Malleable Iron | Aluminum | | Malleable Iron | Aluminum | |
|  1" - 2" | C NEC 8X | ◇ Patented Roller Feature | | | | | | |
| | | 1 | BC100-M | BC100-A | BG100 | BKG100-M | BKG100-A | |
| | | 1-1/4 | BC125-M◇ | BC125-A◇ | BGC125 | BKGC125-M | BKGC125-A | |
| | | 1-1/2 | BC150-M◇ | BC150-A◇ | BG150 | BKG150-M | BKG150-A | |
| | | 2 | BC200-M◇ | BC200-A◇ | BGC200 | BKGC200-M | BKGC200-A | |
| | | 2-1/2 | BC250-M◇ | BC250-A◇ | BGC250 | BKGC250-M | BKGC250-A | |
| | | 3 | BC300-M◇ | BC300-A◇ | BGC300 | BKGC300-M | BKGC300-A | |
|  2-1/2" - 4" | 3-1/2 | BC350-M◇ | BC350-A◇ | BGC350 | BKGC350-M | BKGC350-A | | |
| | 4 | BC400-M◇ | BC400-A◇ | BGC400 | BKGC400-M | BKGC400-A | | |
| |  1" - 2" | LB NEC 6X | ◇ Patented Roller Feature | | | | | |
| | | | 1 | BLB100-M | BLB100-A | BG100 | BKG100-M | BKG100-A |
| 1-1/4 | | | BLB125-M◇ | BLB125-A◇ | BGL125 | BKGL125-M | BKGL125-A | |
| 1-1/2 | | | BLB150-M◇ | BLB150-A◇ | BG150 | BKG150-M | BKG150-A | |
| 2 | | | BLB200-M◇ | BLB200-A◇ | BGL200 | BKGL200-M | BKGL200-A | |
| 2-1/2 | | | BLB250-M◇ | BLB250-A◇ | BGL250 | BKGL250-M | BKGL250-A | |
| 3 | | | BLB300-M◇ | BLB300-A◇ | BGL300 | BKGL300-M | BKGL300-A | |
|  2-1/2" - 4" | 3-1/2 | BLB350-M◇ | BLB350-A◇ | BGL350 | BKGL350-M | BKGL350-A | | |
| | 4 | BLB400-M◇ | BLB400-A◇ | BGL400 | BKGL400-M | BKGL400-A | | |
| |  1" - 2" | UB NEC 6X | ◇ Patented Roller Feature | | | | | |
| | | | 1 | BUB100-M | BUB100-A | BG100 | BKG100-M | BKG100-A |
| 1-1/4 | | | BUB125-M◇ | BUB125-A◇ | BGL125 | BKGL125-M | BKGL125-A | |
| 1-1/2 | | | BUB150-M◇ | BUB150-A◇ | BG150 | BKG150-M | BKG150-A | |
| 2 | | | BUB200-M◇ | BUB200-A◇ | BGL200 | BKGL200-M | BKGL200-A | |
| 2-1/2 | | | BUB250-M◇ | BUB250-A◇ | BGL250 | BKGC250-M | BKGC250-A | |
| 3 | | | BUB300-M◇ | BUB300-A◇ | BGL300 | BKGU300-M | BKGU300-A | |
|  2-1/2" - 4" | 3-1/2 | BUB350-M◇ | BUB350-A◇ | BGL350 | BKGC350-M | BKGC350-A | | |
| | 4 | BUB400-M◇ | BUB400-A◇ | BGL400 | BKGU400-M | BKGU400-A | | |
| |  1" - 2" | LL NEC 6X | 1 | BLL100-M | BLL100-A | BG100 | BKG100-M | BKG100-A |
| | | | 1-1/4 | BLL125-M | BLL125-A | BGL125 | BKGL125-M | BKGL125-A |
| 1-1/2 | | | BLL150-M | BLL150-A | BG150 | BKG150-M | BKG150-A | |
| 2 | | | BLL200-M | BLL200-A | BGL200 | BKGL200-M | BKGL200-A | |
|  1" - 2" | LR NEC 6X | 1 | BLR100-M | BLR100-A | BG100 | BKG100-M | BKG100-A | |
| | | 1-1/4 | BLR125-M | BLR125-A | BGL125 | BKGL125-M | BKGL125-A | |
| | | 1-1/2 | BLR150-M | BLR150-A | BG150 | BKG150-M | BKG150-A | |
| | | 2 | BLR200-M | BLR200-A | BGL200 | BKGL200-M | BKGL200-A | |
|  1" - 2" | T NEC 8X | 1 | BT100-M | BT100-A | BG100 | BKG100-M | BKG100-A | |
| | | 1-1/4 | BT125-M | BT125-A | BGC125 | BKGC125-M | BKGC125-A | |
| | | 1-1/2 | BT150-M | BT150-A | BG150 | BKG150-M | BKG150-A | |
| | | 2 | BT200-M | BT200-A | BGC200 | BKGC200-M | BKGC200-A | |
| | | 2-1/2 | BT250-M | BT250-A | BGC250 | BKGC250-M | BKGC250-A | |
| | | 3 | BT300-M | BT300-A | BGC300 | BKGC300-M | BKGC300-A | |
| | | 3-1/2 | BT350-M | BT350-A | BGC350 | BKGC350-M | BKGC350-A | |
|  2-1/2" - 4" | 4 | BT400-M | BT400-A | BGC400 | BKGC400-M | BKGC400-A | | |

For Dimensions, See Pages A-22 and A-23.

Effective September, 2005
Copyright 2005



800-621-1506
www.appletonelec.com

Bending RADII and Bending Space of Appleton LB and UB Moguls

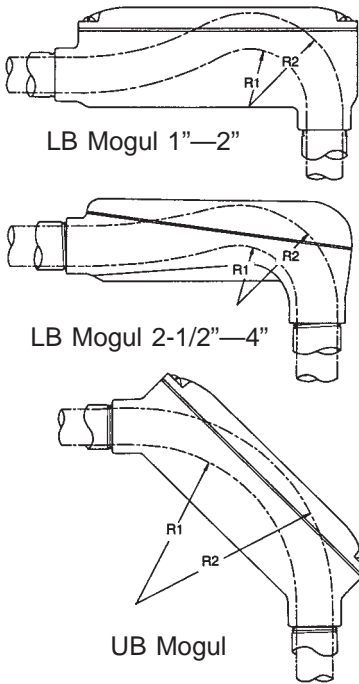

Bending RADII of Appleton Moguls

| Catalog Number | Hub Size (Inches) | Type | R1 (Inches) | R2 (Inches) |
|----------------|-------------------|------|-------------|-------------|
| BLB100-A,M | 1 | LB | 1.625 | 2.625 |
| BLB125-A,M | 1-1/4 | | 2.250 | 3.625 |
| BLB150-A,M | 1-1/2 | | 2.625 | 4.125 |
| BLB200-A,M | 2 | | 3.000 | 5.000 |
| BLB250-A,M | 2-1/2 | | 3.875 | 6.250 |
| BLB300-A,M | 3 | | 5.000 | 8.000 |
| BLB350-A,M | 3-1/2 | | 5.000 | 8.375 |
| BLB400-A,M | 4 | | 6.250 | 10.250 |
| BUB100-A,M | 1 | UB | 4.500 | 5.500 |
| BUB125-A,M | 1-1/4 | | 4.625 | 6.000 |
| BUB150-A,M | 1-1/2 | | 7.000 | 8.500 |
| BUB200-A,M | 2 | | 7.500 | 9.500 |
| BUB250-A,M | 2-1/2 | | 13.125 | 15.500 |
| BUB300-A,M | 3 | | 13.875 | 16.875 |
| BUB350-A,M | 3-1/2 | | 19.750 | 23.250 |
| BUB400-A,M | 4 | | 20.750 | 24.750 |

Appleton Compliances with NEC Bending Space Requirements

BENDING SPACE DEFINED:

NEC 370-28(a)(2) Exception.

This article applies to LB and UB Moguls, defines bending space and refers to NEC 373-6(a) Table as guideline for determining minimum bending space distance.

Bending space is illustrated as Dimension "A" below:

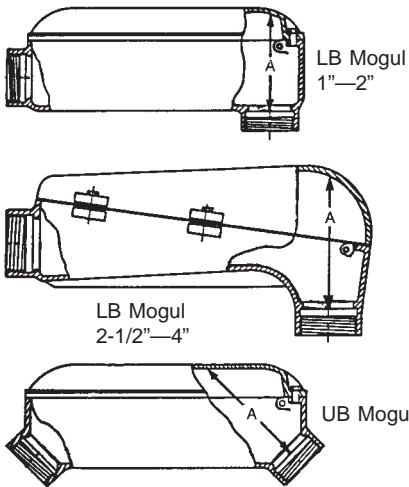

MINIMUM WIRE BENDING SPACE:

NEC 373-6(a) Table

The applicable portion of this table is shown below. Only the "1 Wire Per Terminal" column is retained, because the others are not applicable. Example for using table below and table at right:

EXAMPLE:

350MCM wire size requires 5" bending space. A 2" LB or UB Appleton Mogul is suitable.

| AWG or Circular-Mill. Size of Wire | 1 Wire per Terminal Min. Bending Space |
|------------------------------------|--|
| 14-10 | Not Specified |
| 8-6 | 1-1/2" |
| 4-3 | 2" |
| 2 | 2-1/2" |
| 1 | 3" |
| 0-00 | 3-1/2" |
| 000-0000 | 4" |
| 250 MCM | 4-1/2" |
| 300-350 MCM | 5" |
| 400-500 MCM | 6" |
| 600-700 MCM | 8" |
| 750-900 MCM | 8" |
| 1,000-1,250 MCM | 10" |
| 1,500-2,000 MCM | 12" |

BENDING SPACE OF APPLETON MOGULS (Dim. "A" in sketches at left)

| Mogul Size | Type | Distance |
|------------|--------|----------|
| 1 | LB,UB | 2-1/2" |
| 1-1/4 | LB,UB | 3-1/2" |
| 1-1/2 | LB, UB | 4" |
| 2 | LB, UB | 5" |
| 2-1/2 | LB, UB | 6" |
| 3 | LB, UB | 8" |
| 3-1/2 | LB, UB | 8" |
| 4 | LB, UB | 10" |

NOTE ON RADII TABLE: Secure cable or wire bending radius from manufacturer. Then select a mogul having this radius or more. If radius is 6-1/4", an LB 2-1/2" mogul or BUB 1-1/2" mogul is suitable.

NOTE ON NEC 373-6(a) TABLE: Because cable sizes vary, table is limited to single wire sizes. Use as guideline only for cable sizes.

NEC 6x8x Series Moguls (C, LB and UB) Comply with NEC Large-Wire Requirements

Applicable NEC References for C, LB and UB Moguls

●Straight Pull Length Requirements:
NEC 314.28(A)(2)— C Moguls
“... shall not be less than eight times the trade diameter of the largest raceway.”
(See table at right.)

●Angle or U Pull Length Requirements:
NEC 314.28(A)(2)— LB, UB Moguls
“The distance between each raceway entry inside the box and the opposite wall of the box shall not be less than six times the tradediameter of the largest raceway.”
(See next page.)

●Bending-Space Requirements: NEC 314.28(A)(2). Exception 312.6(A) Table— LB, UB Moguls
“Where a conduit or cable entry is in the wall of a box or conduit body opposite to a removable cover.” (See dim. “A” below, table on next page and page 11G.)

●Length and Bending Space Requirements:

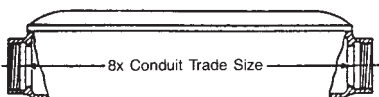

C Mogul— 1" thru 4"

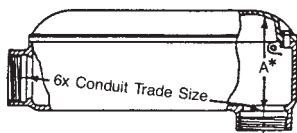

LB Mogul— 1" thru 2"

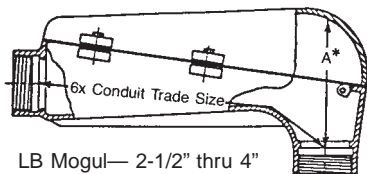

LB Mogul— 2-1/2" thru 4"

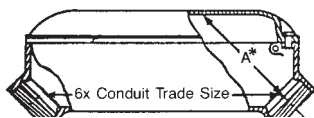

UB Mogul— 1" thru 4"

*Dimension “A” is bending space.

BENDING SPACE EXAMPLE: LB with 3" hubs (Cat. No. BLB300-M) using 500MCM wire with four conductors.

Table on next page shows that, in this example, NEC requires a bending space of 6" and that the Appleton 3" LB provides a bending space of 8".

**For table on angle or U pulls, see next page.

C Moguls— Straight Pulls: Maximum No. Conductors, Minimum Lengths**

| WIRE SIZE ① | MAX. NO. CONDUCTORS PER NEC ② | LENGTH REQUIREMENTS (Conduit Stop to Conduit Stop) | | MAX. NO. CONDUCTORS PER NEC ② | LENGTH REQUIREMENTS (Conduit Stop to Conduit Stop) | |
|-------------|-------------------------------|--|----------|-------------------------------|--|----------|
| | | PER NEC ③ | APPLETON | | PER NEC ③ | APPLETON |
| | 1" HUBS | BC100-M and BC100-A | | 1-1/4" HUBS | BC125-M and BC125-A | |
| 4 | 4 | 8" | 8" | 7 | 10" | 10" |
| 3 | 3 | 8" | 8" | 6 | 10" | 10" |
| 2 | 3 | 8" | 8" | 5 | 10" | 10" |
| 1 | - | - | - | 3 | 10" | 10" |
| 0 | - | - | - | 3 | 10" | 10" |
| | 1-1/2" HUBS | BC150-M and BC150-A | | 2" HUBS | BC200-M and BC200-A | |
| 4 | 9 | 12" | 12" | 16 | 16" | 16" |
| 3 | 8 | 12" | 12" | 13 | 16" | 16" |
| 2 | 7 | 12" | 12" | 11 | 16" | 16" |
| 1 | 5 | 12" | 12" | 8 | 16" | 16" |
| 0 | 4 | 12" | 12" | 7 | 16" | 16" |
| 00 | 3 | 12" | 12" | 6 | 16" | 16" |
| 000 | 3 | 12" | 12" | 5 | 16" | 16" |
| 0000 | - | - | - | 4 | 16" | 16" |
| 250 | - | - | - | 3 | 16" | 16" |
| 300 | - | - | - | 3 | 16" | 16" |
| | 2-1/2" HUBS | BC250-M and BC250-A | | 3" HUBS | BC300-M and BC300-A | |
| 4 | 22 | 20" | 20" | 35 | 24" | 24" |
| 3 | 19 | 20" | 20" | 29 | 24" | 24" |
| 2 | 16 | 20" | 20" | 25 | 24" | 24" |
| 1 | 12 | 20" | 20" | 18 | 24" | 24" |
| 0 | 10 | 20" | 20" | 15 | 14" | 24" |
| 00 | 8 | 20" | 20" | 13 | 24" | 24" |
| 000 | 7 | 20" | 20" | 11 | 24" | 24" |
| 0000 | 6 | 20" | 20" | 9 | 24" | 24" |
| 250 | 4 | 20" | 20" | 7 | 24" | 24" |
| 300 | 4 | 20" | 20" | 6 | 24" | 24" |
| 350 | 3 | 15" | 20" | 5 | 24" | 24" |
| 400 | 3 | 15" | 20" | 5 | 24" | 24" |
| 500 | - | - | - | 4 | 24" | 24" |
| 600 | - | - | - | 3 | 24" | 24" |
| 700 | - | - | - | 3 | 24" | 24" |
| | 3-1/2" HUBS | BC350-M and BC350-A | | 4" HUBS | BC400-M and BC400-A | |
| 4 | 47 | 28" | 28" | 60 | 32" | 32" |
| 3 | 39 | 28" | 28" | 51 | 32" | 32" |
| 2 | 33 | 28" | 28" | 43 | 32" | 32" |
| 1 | 25 | 28" | 28" | 32 | 32" | 32" |
| 0 | 21 | 28" | 28" | 27 | 32" | 32" |
| 00 | 17 | 28" | 28" | 32 | 32" | 32" |
| 000 | 14 | 28" | 28" | 18 | 32" | 32" |
| 0000 | 12 | 28" | 28" | 15 | 32" | 32" |
| 250 | 10 | 28" | 28" | 12 | 32" | 32" |
| 300 | 8 | 28" | 28" | 11 | 32" | 32" |
| 350 | 7 | 28" | 28" | 9 | 32" | 32" |
| 400 | 6 | 28" | 28" | 8 | 32" | 32" |
| 500 | 5 | 28" | 28" | 7 | 32" | 32" |
| 600 | 4 | 28" | 28" | 5 | 32" | 32" |
| 700 | 4 | 28" | 28" | 5 | 32" | 32" |
| 750 | 3 | 28" | 28" | 4 | 32" | 32" |
| 800 | 3 | 28" | 28" | 4 | 32" | 32" |
| 900 | 3 | 28" | 28" | 4 | 32" | 32" |
| 1000 | - | - | - | 3 | 32" | 32" |

① NEC 370-28(a). Limited to minimum #4 wire. ② NEC Chapter 9, Table 3B.

③ NEC 370-28(a)(1). This is 8 times conduit trade size

A-28

NEC 6x8x Series Moguls (C, LB and UB) Comply with NEC Large-Wire Requirements

LB and UB Moguls- Angle or U Pulls: Max. No. Conductors, Min. Lengths, Min. Bending Spaces

| WIRE SIZE ¹ | MAX. NO. CONDUCTORS PER NEC ² | LENGTH REQUIREMENTS (Conduit Stop to Conduit Stop) | | "A" BENDING SPACE REQUIREMENTS | | MAX. NO. CONDUCTORS PER NEC ² | LENGTH REQUIREMENTS (Conduit Stop to Conduit Stop) | | "A" BENDING SPACE REQUIREMENTS | | |
|------------------------|--|---|----------|--------------------------------|----------|--|--|---|--------------------------------|----------|--|
| | | PER NEC ³ | APPLETON | PER NEC ⁴ | APPLETON | | PER NEC ³ | APPLETON | PER NEC ⁴ | APPLETON | |
| 1" HUBS | | BLB100-M, BLB100-A BUB100-M and BUB100-A | | | | 1-1/4" HUBS | | BLB125-M, BLB125-A BUB125-M and BUB200-A | | | |
| 4 | 4 | 6" | 6" | 2" | 2-1/2" | 7 | 7-1/2" | 7-1/2" | 2" | 3-1/2" | |
| 3 | 3 | 6" | 6" | 2" | 2-1/2" | 6 | 7-1/2" | 7-1/2" | 2" | 3-1/2" | |
| 2 | 3 | 6" | 6" | 2-1/2" | 2-1/2" | 5 | 7-1/2" | 7-1/2" | 2-1/2" | 3-1/2" | |
| 1 | - | - | - | - | - | 3 | 7-1/2" | 7-1/2" | 3" | 3-1/2" | |
| 0 | - | - | - | - | - | 3 | 7-1/2" | 7-1/2" | 3-1/2" | 3-1/2" | |
| 1-1/2" HUBS | | BLB150-M, BLB150-A BUB150-M and BUB150-A | | | | 2" HUBS | | BLB200-M, BLB200-A BUB200-M and BUB200-A | | | |
| 4 | 9 | 9" | 9" | 2" | 4" | 16 | 12" | 12" | 2" | 5" | |
| 3 | 8 | 9" | 9" | 2" | 4" | 13 | 12" | 12" | 2" | 5" | |
| 2 | 7 | 9" | 9" | 2-1/2" | 4" | 11 | 12" | 12" | 2-1/2" | 5" | |
| 1 | 5 | 9" | 9" | 3" | 4" | 8 | 12" | 12" | 3" | 5" | |
| 0 | 4 | 9" | 9" | 3-1/2" | 4" | 7 | 12" | 12" | 3-1/2" | 5" | |
| 00 | 3 | 9" | 9" | 3-1/2" | 4" | 6 | 12" | 12" | 3-1/2" | 5" | |
| 000 | 3 | 9" | 9" | 4" | 4" | 5 | 12" | 12" | 4" | 5" | |
| 0000 | - | - | - | - | - | 4 | 12" | 12" | 4" | 5" | |
| 250 | - | - | - | - | - | 3 | 12" | 12" | 4-1/2" | 5" | |
| 300 | - | - | - | - | - | 3 | 12" | 12" | 5" | 5" | |
| 2-1/2" HUBS | | BLB250-M, BLB250-A BUB250-M and BUB250-A | | | | 3" HUBS | | BLB300-M, BLB300-A BUB300-M and BUB300-A | | | |
| 4 | 22 | 15" | 15" | 2" | 6" | 35 | 18" | 18" | 2" | 8" | |
| 3 | 19 | 15" | 15" | 2" | 6" | 29 | 18" | 18" | 2" | 8" | |
| 2 | 16 | 15" | 15" | 2-1/2" | 6" | 25 | 18" | 18" | 2-1/2" | 8" | |
| 1 | 12 | 15" | 15" | 3" | 6" | 18 | 18" | 18" | 3" | 8" | |
| 0 | 10 | 15" | 15" | 3-1/2" | 6" | 15 | 18" | 18" | 3-1/2" | 8" | |
| 00 | 8 | 15" | 15" | 3-1/2" | 6" | 13 | 18" | 18" | 3-1/2" | 8" | |
| 000 | 7 | 15" | 15" | 4" | 6" | 11 | 18" | 18" | 4" | 8" | |
| 0000 | 6 | 15" | 15" | 4" | 6" | 9 | 18" | 18" | 4" | 8" | |
| 250 | 4 | 15" | 15" | 4-1/2" | 6" | 7 | 18" | 18" | 4-1/2" | 8" | |
| 300 | 4 | 15" | 15" | 5" | 6" | 6 | 18" | 18" | 5" | 8" | |
| 350 | 3 | 15" | 15" | 5" | 6" | 5 | 18" | 18" | 5" | 8" | |
| 400 | 3 | 15" | 15" | 6" | 6" | 5 | 18" | 18" | 6" | 8" | |
| 500 | - | - | - | - | - | 4 | 18" | 18" | 6" | 8" | |
| 600 | - | - | - | - | - | 3 | 18" | 18" | 8" | 8" | |
| 700 | - | - | - | - | - | 3 | 18" | 18" | 8" | 8" | |
| 3-1/2" HUBS | | BLB350-M, BLB350-A BUB350-M and BUB350-A | | | | 4" HUBS | | BLB400-M, BLB400-A BUB400-M and BUB400-A | | | |
| 4 | 47 | 21" | 21" | 2" | 8" | 60 | 24" | 24" | 2" | 10" | |
| 3 | 39 | 21" | 21" | 2" | 8" | 51 | 24" | 24" | 2" | 10" | |
| 2 | 33 | 21" | 21" | 2-1/2" | 8" | 43 | 24" | 24" | 2-1/2" | 10" | |
| 1 | 25 | 21" | 21" | 3" | 8" | 32 | 24" | 24" | 3" | 10" | |
| 0 | 21 | 21" | 21" | 3-1/2" | 8" | 27 | 24" | 24" | 3-1/2" | 10" | |
| 00 | 17 | 21" | 21" | 3-1/2" | 8" | 22 | 24" | 24" | 3-1/2" | 10" | |
| 000 | 14 | 21" | 21" | 4" | 8" | 18 | 24" | 24" | 4" | 10" | |
| 0000 | 12 | 21" | 21" | 4" | 8" | 15 | 24" | 24" | 4" | 10" | |
| 250 | 10 | 21" | 21" | 4-1/2" | 8" | 12 | 24" | 24" | 4-1/2" | 10" | |
| 300 | 8 | 21" | 21" | 5" | 8" | 11 | 24" | 24" | 5" | 10" | |
| 350 | 7 | 21" | 21" | 5" | 8" | 9 | 24" | 24" | 5" | 10" | |
| 400 | 6 | 21" | 21" | 6" | 8" | 8 | 24" | 24" | 6" | 10" | |
| 500 | 5 | 21" | 21" | 6" | 8" | 7 | 24" | 24" | 6" | 10" | |
| 600 | 4 | 21" | 21" | 8" | 8" | 5 | 24" | 24" | 8" | 10" | |
| 700 | 4 | 21" | 21" | 8" | 8" | 5 | 24" | 24" | 8" | 10" | |
| 750 | 3 | 21" | 21" | 8" | 8" | 4 | 24" | 24" | 8" | 10" | |
| 800 | 3 | 21" | 21" | 8" | 8" | 4 | 24" | 24" | 8" | 10" | |
| 900 | 3 | 21" | 21" | 8" | 8" | 4 | 24" | 24" | 8" | 10" | |
| 1000 | - | - | - | - | - | 3 | 24" | 24" | 10" | 10" | |

¹ NEC 370-28(a). Limited to minimum #4 wire. ² NEC Chapter 9, Table 3B. ³ NEC 370-28(a)(2) This is 6 times conduit trade size.

⁴ NEC 370-28(a)(2) Exception (373-6(a) Table). This is distance "A" bending space illustrated on preceding page.

Dimensions: Mogul Types C, T, LL and LR

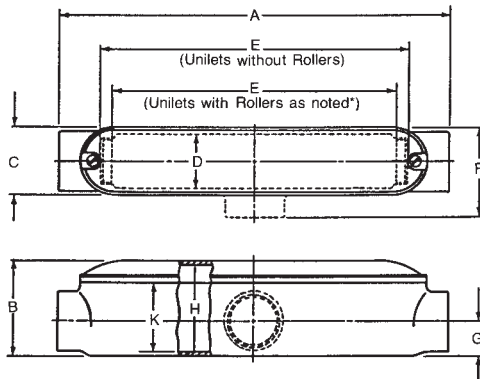

Types C & T

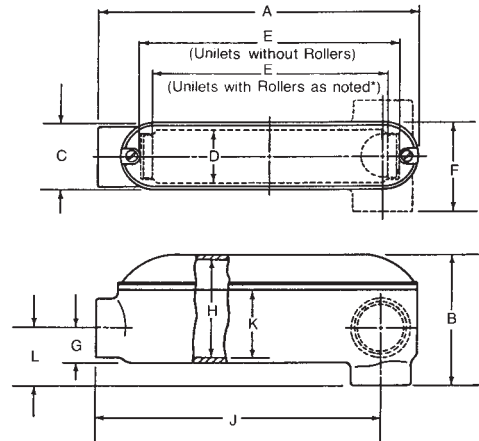

Types LB,† LL & LR

| Dimensions in Inches | | | | | | | | | | | |
|----------------------|----------------------|-------|------|------|------|-------|------|------|------|-------|------|
| Type Mogul | Hub Trade Size (In.) | A | B | C | D | E | F | G | H | J | K |
| C | 1 | 9.81 | 2.75 | 2.38 | 1.88 | 6.63 | | .94 | 2.44 | | 1.88 |
| | 1-1/4* | 12.00 | 3.31 | 2.38 | 1.88 | 7.69 | | 1.16 | 3.00 | | 2.19 |
| | 1-1/2* | 13.94 | 3.75 | 3.13 | 2.50 | 9.31 | | 1.38 | 3.38 | | 2.56 |
| | 2* | 17.94 | 4.44 | 3.13 | 2.50 | 13.00 | | 1.63 | 4.00 | | 3.18 |
| | 2-1/2* | 23.25 | 5.13 | 4.63 | 3.75 | 17.50 | | 1.81 | 4.63 | | 3.63 |
| | 3* | 26.88 | 5.94 | 4.63 | 3.63 | 21.00 | | 2.16 | 5.44 | | 4.38 |
| | 3-1/2* | 31.38 | 7.19 | 5.63 | 4.50 | 24.94 | | 2.50 | 6.69 | | 4.88 |
| | 4* | 35.38 | 7.56 | 5.63 | 4.50 | 28.94 | | 2.75 | 7.06 | | 5.25 |
| T | 1 | 9.81 | 2.75 | 2.38 | 1.88 | 6.63 | 3.25 | .94 | 2.44 | | 1.88 |
| | 1-1/4 | 12.00 | 3.31 | 2.38 | 1.88 | 8.56 | 3.38 | 1.16 | 3.00 | | 2.19 |
| | 1-1/2 | 13.94 | 3.75 | 3.13 | 2.50 | 10.38 | 4.13 | 1.38 | 3.38 | | 2.56 |
| | 2 | 17.94 | 4.44 | 3.13 | 2.50 | 14.13 | 4.13 | 1.63 | 4.00 | | 3.18 |
| | 2-1/2 | 23.25 | 5.13 | 4.63 | 3.75 | 18.69 | 6.00 | 1.81 | 4.63 | | 3.63 |
| | 3 | 26.88 | 5.94 | 4.63 | 3.63 | 22.19 | 6.00 | 2.16 | 5.44 | | 4.38 |
| | 3-1/2 | 31.38 | 7.19 | 5.63 | 4.50 | 26.19 | 7.25 | 2.50 | 6.69 | | 4.88 |
| | 4 | 35.38 | 7.56 | 5.63 | 4.50 | 30.19 | 7.25 | 2.75 | 7.06 | | 5.25 |
| LL,LR | 1 | 8.94 | 2.75 | 2.38 | 1.88 | 6.63 | 3.25 | .94 | 2.44 | 7.88 | 1.88 |
| | 1-1/4 | 9.69 | 3.31 | 2.38 | 1.88 | 7.25 | 3.38 | 1.16 | 3.00 | 8.50 | 2.19 |
| | 1-1/2 | 13.00 | 3.75 | 3.13 | 2.50 | 10.38 | 4.13 | 1.38 | 3.38 | 11.63 | 2.56 |
| | 2 | 14.63 | 5.00 | 3.13 | 2.50 | 11.81 | 4.13 | 1.63 | 4.56 | 12.94 | 3.44 |

* Furnished with patented rollers for easier cable pulling.

| Type Mogul | Number of Cover Holes |
|---|-----------------------|
| All LB, LL and LR plus C, T and UB 1" thru 2" sizes | Two |
| C, T and UB 2-1/2" thru 4" sizes | Four |
| All LB 2-1/2" thru 4" sizes | Six |

† See page A-23 for dimension table on LB Mogul type.

A-30

Dimensions: Mogul Types LB and UB

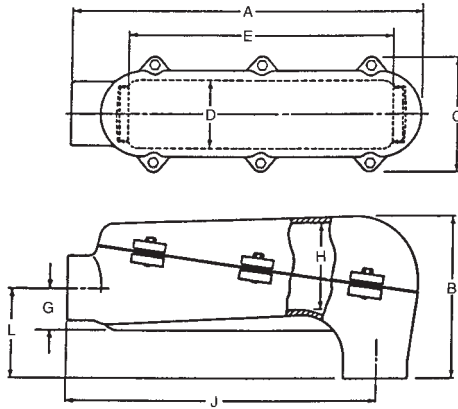

Type LB (2-1/2" thru 4")†

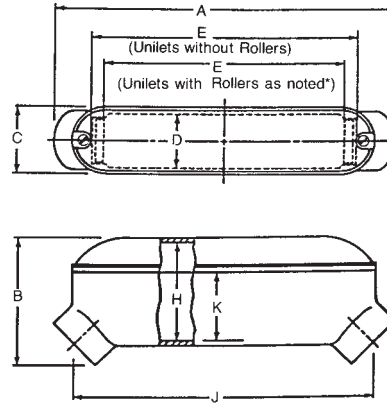

Type UB

Dimensions In Inches

| Type Mogul | Hub Trade Size (In.) | A | B | C | D | E | G | H | J | K | L |
|------------|----------------------|-------|-------|------|------|-------|------|------|-------|------|------|
| LB | 1 | 8.94 | 3.63 | 2.38 | 1.88 | 6.63 | .94 | 2.44 | 7.88 | 1.88 | 1.88 |
| | 1-1/4* | 9.69 | 4.75 | 2.38 | 1.88 | 6.31 | 1.16 | 3.44 | 8.50 | 2.63 | 2.16 |
| | 1-1/2* | 13.00 | 5.25 | 3.13 | 2.50 | 9.31 | 1.38 | 3.94 | 11.63 | 3.06 | 2.38 |
| | 2* | 14.63 | 6.31 | 3.13 | 2.50 | 10.75 | 1.63 | 4.88 | 12.94 | 3.44 | 2.69 |
| | 2-1/2* | 17.88 | 8.00 | 5.88 | 3.50 | 13.75 | 2.13 | 4.13 | 15.81 | | 4.56 |
| | 3* | 21.06 | 10.00 | 5.88 | 3.50 | 17.00 | 2.50 | 5.13 | 18.50 | | 5.38 |
| | 3-1/2* | 24.31 | 10.25 | 7.00 | 4.63 | 19.88 | 3.00 | 4.75 | 21.38 | | 6.63 |
| | 4* | 27.50 | 12.50 | 7.00 | 4.63 | 23.00 | 3.25 | 6.38 | 24.38 | | 7.00 |
| UB | 1 | 9.63 | 3.50 | 2.38 | 1.88 | 6.63 | | 2.44 | 8.44 | 1.88 | |
| | 1-1/4* | 10.25 | 4.13 | 2.38 | 1.88 | 6.31 | | 3.00 | 8.94 | 2.19 | |
| | 1-1/2* | 13.69 | 4.63 | 3.13 | 2.50 | 9.31 | | 3.38 | 12.19 | 2.56 | |
| | 2* | 15.25 | 5.00 | 3.13 | 2.50 | 10.75 | | 4.56 | 13.38 | 3.18 | |
| | 2-1/2* | 22.88 | 7.06 | 4.63 | 3.75 | 17.50 | | 5.44 | 20.13 | 4.38 | |
| | 3* | 22.88 | 7.31 | 4.63 | 3.75 | 17.50 | | 6.81 | 20.13 | 4.38 | |
| | 3-1/2* | 30.88 | 8.94 | 5.63 | 4.50 | 24.88 | | 7.06 | 27.50 | 5.25 | |
| | 4* | 30.88 | 10.31 | 5.63 | 4.50 | 24.88 | | 8.44 | 27.50 | 5.25 | |

* Furnished with patented rollers for easier cable pulling.

† See page A-22 for illustration of LB in sizes 1" thru 2".

| Type Mogul | Number of Cover Holes |
|---|-----------------------|
| All LB, LL and LR plus C, T and UB 1" thru 2" sizes | Two |
| C, T and UB 2-1/2" thru 4" sizes | Four |
| All LB 2-1/2" thru 4" sizes | Six |

Wiring Capacity: Mogul Bodies with Cover

Body and Cover Capacities Combined for Total Usable Capacity per NEC 370-6(a)(1).

Mogul Bodies with Covers: Malleable Iron and Aluminum CAPACITY IN CUBIC INCHES

| Hub Size, Inches | Type Mogul | Capacity, Cu. In. |
|------------------|----------------------------|----------------------|
| 1 | C, LB, LL LR, T, UB | 31 |
| 1-1/4 | C, T LB LL, LR UB | 50 48 42 40 |
| 1-1/2 | C, LL, LR, T LB UB | 93 107 91 |
| 2 | C, T LB LL, LR, UB | 143 145 134 |
| 2-1/2 | C, T LB UB | 335 210 375 |
| 3 | C, T LB UB | 475 345 445 |
| 3-1/2 | C, T LB UB | 830 500 840 |
| 4 | C, T LB UB | 1010 740 960 |



LBD and LBDN Pulling Fittings: Malleable Iron, Aluminum

UNILET[®] for use with Threaded Rigid Metal Conduit and IMC.
Furnished with Cover and Gasket.

Features

- Serve as pulling fittings—ideal for heavy, difficult-to-bend conductors.
- Make 90° bends in conduit—straight pull through hubs in either direction.
- Use as service entrance fitting.
- Complete with gasketed covers.

Standard Materials



- *Unilets and covers:* malleable iron (some in aluminum).
- *Gaskets:* Neoprene or composition fiber.

Standard Finishes

- *Malleable iron bodies and covers:* triple-coat — (1) zinc electroplate, (2) dichromate and (3) epoxy powder coat.
- *Aluminum bodies and covers:* epoxy powder coat.

Compliances

- UL Standard 514A.
- Federal Spec. W-C-586B.
- LBDN complies with NEC 370-28(a)(2).
- Suitable for classified location use in Class I, Division 2 areas, if installed in compliance with NEC 501-4(b).
- Appleton malleable iron conforms to ASTM A47-77, Grade 32510.
- Appleton aluminum products are produced from a high strength copper-free (4/10 of 1% max.) alloy.

| | Type | Hub Size (in) | Catalog Number | |
|---|------|---------------|----------------|-----------|
| | | | Malleable Iron | Aluminum |
|  1/2" thru 1" | LBD | 1/2 | LBD50-M | — |
| | | 3/4 | LBD75-M | — |
| | | 1 | LBD100-M | — |
|  1-1/4" thru 2" | LBD | 1-1/4 | LBD125-M | LBD125-A |
| | | 1-1/2 | LBD150-M | LBD150-A |
| | | 2 | LBD200-M | LBD200-A |
|  2-1/2" thru 4" | LBDN | 2-1/2 | LBDN250-M | LBDN250-A |
| | | 3 | LBDN300-M | LBDN300-A |
| | | 3-1/2 | LBDN350-M | LBDN350-A |
| | | 4 | LBDN400-M | LBDN400-A |

LBD Dimensions

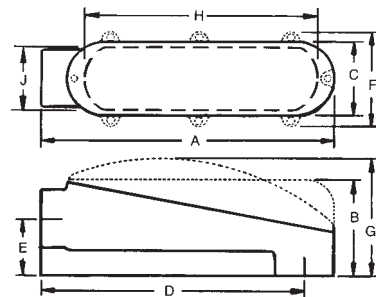

LBDN Dimensions

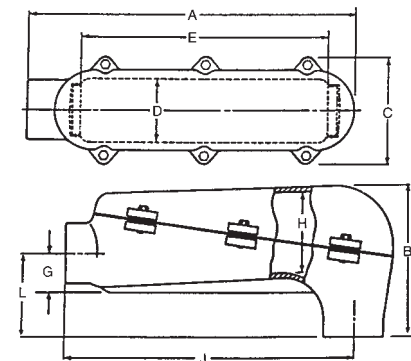

LBDN Series Dimensions, Inches

| Hub Trade Size (In.) | A | B | C | D | E | G | H | J | L |
|----------------------|-------|-------|------|------|-------|------|------|-------|------|
| 2-1/2 | 17.88 | 8.00 | 5.88 | 3.50 | 13.75 | 2.13 | 4.13 | 15.81 | 4.56 |
| 3 | 21.06 | 10.00 | 5.88 | 3.50 | 17.00 | 2.50 | 5.13 | 18.50 | 5.38 |
| 3-1/2 | 24.31 | 10.25 | 7.00 | 4.63 | 19.88 | 3.00 | 4.75 | 21.38 | 6.63 |
| 4 | 27.50 | 12.50 | 7.00 | 4.63 | 23.00 | 3.25 | 6.38 | 24.38 | 7.00 |

LBD Series Dimensions, Inches

| Hub Trade Size (In.) | A | B | C | D | E | F | G | H | J |
|----------------------|-------|------|------|-------|------|------|------|-------|------|
| 1/2 | 5.00 | 2.19 | 1.31 | 4.38 | 1.25 | - | - | 3.56 | .94 |
| 3/4 | 6.19 | 2.50 | 1.50 | 5.50 | 1.44 | - | - | 4.75 | 1.13 |
| 1 | 6.38 | 2.69 | 1.75 | 5.50 | 1.69 | - | - | 4.94 | 1.38 |
| 1-1/4 | 8.50 | - | 2.63 | 7.50 | 2.13 | 3.38 | 4.75 | 7.19 | 2.00 |
| 1-1/2 | 12.25 | - | 3.13 | 10.94 | 2.31 | 4.13 | 4.88 | 10.63 | 2.56 |
| 2 | 12.44 | - | 3.13 | 10.94 | 2.75 | 4.13 | 5.25 | 10.63 | 2.56 |

LBD/LBDN Bodies and Covers: Malleable Iron and Aluminum

| Hub Size (Inches) | Capacity, Cu. In. |
|-------------------|-------------------|
| 1/2 | 4.0 |
| 3/4 | 8.0 |
| 1 | 12.0 |
| 1-1/4 | 37.0 |
| 1-1/2 | 66.0 |
| 2 | 81.0 |
| 2-1/2 (LBDN) | 210.0 |
| 3 (LBDN) | 345.0 |
| 3-1/2 (LBDN) | 500.0 |
| 4 (LBDN) | 740.0 |

JB Conduit Outlet Boxes, Covers, and Hangers: Malleable Iron, Aluminum

UNILET® for use with Threaded Rigid Metal Conduit and IMC.

NOTE: Refer to page A-31 for Wiring Capacity Tables.

Features

- Raintight when enclosed and gasketed with hub or blank covers.
- For exposed or concealed use.
- Blind cover screw holes prevent conductor damage during installation, provide water-tightness.
- Available in three inside depths—1-5/16", 2-1/16", and 3-1/8".
- Order with or without mounting lugs.
- Furnished with four tapped holes and two close-up plugs.
- Malleable iron or aluminum.
- Cushion fixture hangers enclosed and gasketed (vaportight).

Standard Materials

- *JB conduit outlet boxes and covers plus JB fixture hangers:* malleable iron.

- *JB-A boxes and covers:* copper-free aluminum.

- *Gaskets:* Neoprene or composition fiber.

Standard Finishes

- *Malleable iron conduit outlet boxes, and hub covers:* triple-coat — (1) zinc electroplate, (2) dichromate and (3) epoxy powder coat.
- *Fixture hangers, JB 1/2" hub and blank covers:* (1) zinc electroplate, (2) dichromate and (3) epoxy powder coat.
- *Aluminum JB conduit outlet boxes:* epoxy powder coat.





Compliances

- UL Standard 514A.



JB conduit outlet box. Choice of three depths. JBX shown.



- Federal Spec. W-C-586B.
- Suitable for classified location use in Class I, Division 2 areas, if installed in compliance with NEC 501-4(b).
- Appleton malleable iron conforms to ASTM A47-77, Grade 32510.
- Appleton aluminum products are produced from a high strength copper-free (4/10 of 1% max.) alloy.

| Description | Hub Size (Inches) | Length (A) | Catalog Number | |
|---|-------------------|------------|----------------|-------------|
| | | | Malleable Iron | Aluminum |
| JBX — 1-5/16" inside depth | | | | |
|  Furnished with four tapped openings and two close-up plugs. Less mounting lugs | 1/2 | — | JBX-50 | — |
| | 3/4 | — | JBX-75 | — |
| | 1 | — | JBX-100 | — |
|  With mounting lugs | 1/2 | — | JBX-50L | JBX50L-A |
| | 3/4 | — | JBX-75L | JBX75L-A |
| | 1 | — | JBX-100L | — |
| JBDX — 2-1/16" inside depth | | | | |
|  Furnished with four tapped openings and two close-up plugs. Less mounting lugs | 1/2 | — | JBDX-50 | — |
| | 3/4 | — | JBDX-75 | — |
| | 1 | — | JBDX-100 | — |
|  With mounting lugs | 1/2 | — | JBDX-50L | — |
| | 3/4 | — | JBDX-75L | — |
| | 1 | — | JBDX-100L | — |
| JBLX — 3-1/8" inside depth | | | | |
|  Furnished with four tapped openings and two close-up plugs. With removable mounting lugs | 1/2 | — | JBLX-50L | JBLX-50L-A |
| | 3/4 | — | JBLX-75L | JBLX-75L-A |
| | 1 | — | JBLX-100L | JBLX-100L-A |

JB Conduit Outlet Boxes, Covers, and Hangers: Malleable Iron, Aluminum

UNILET® for use with Threaded Rigid Metal Conduit and IMC.

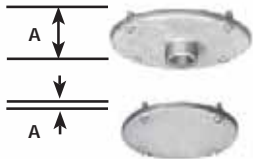
NOTE: Refer to page A-31 for Wiring Capacity Tables.

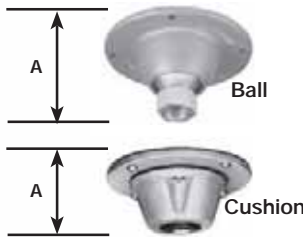
| Description | Hub Size (Inches) | Length (A) | Catalog Number | |
|---|-------------------|---------------|------------------|------------------|
| | | | Malleable Iron | Aluminum |
|  <p>JBX, JBDX, JBLX — Cast Covers Furnished with screws. When used with gasket provides raintight fit, supports 250 lbs. Hub Covers</p> | 1/2 | .75" (1.9cm) | JBK-50 | JBK-50-A |
| | 3/4 | .94" (2.3cm) | JBK-75 | JBK-75-A |
| | Blank | .19" (0.4cm) | JBK-B | JBK-1B-CA |
| Cover | | | | |
|  <p>JBX, JBDX, JBLX — Gasket, Neoprene</p> | — | — | JB-GK-N | JB-GK-N |
|  <p>JBX, JBDX, JBLX — Flexible Fixture Hangers Furnished with gasket and screws. Ball Type — 15° swing in all directions, support 250 lbs. Cushion type, enclosed and gasketed — 8° swing in all directions. Cushions 40 lbs., supports 250 lbs.</p> | 1/2 | 2.56" (6.5cm) | JBK-50-BS | — |
| | 3/4 | 2.56" (6.5cm) | JBK-75-BS | — |
| | 1/2 | 1.63 (4.1cm) | JBK-50-CS | — |
| | 3/4 | 1.63 (4.1cm) | JBK-75-CS | — |

Dimensions

| Hub size (Inches) | Dimension "A" (Inches) | | |
|-------------------|------------------------|------|------|
| | JBX | JBDX | JBLX |
| 1/2 | .75 | .75 | .75 |
| 3/4 | .88 | .88 | .88 |
| 1 | .81 | 1.06 | 1.06 |

| Hub size (Inches) | Dimension "A" (Centimeters) | | |
|-------------------|-----------------------------|------|------|
| | JBX | JBDX | JBLX |
| 1/2 | 1.9 | 1.9 | 1.9 |
| 3/4 | 2.2 | 2.2 | 2.2 |
| 1 | 2.1 | 2.7 | 2.7 |

JB Malleable Iron and Aluminum Boxes.

CAPACITY IN CUBIC INCHES*

| Hub | | | |
|------------|------|------|------|
| Size (In.) | JBX | JBDX | JBLX |
| 1/2 | 15.5 | 23.0 | 33.0 |
| 3/4 | 15.5 | 23.0 | 33.0 |
| 1 | 15.5 | 23.0 | 33.0 |

*JB covers add no additional cubic inch capacity.

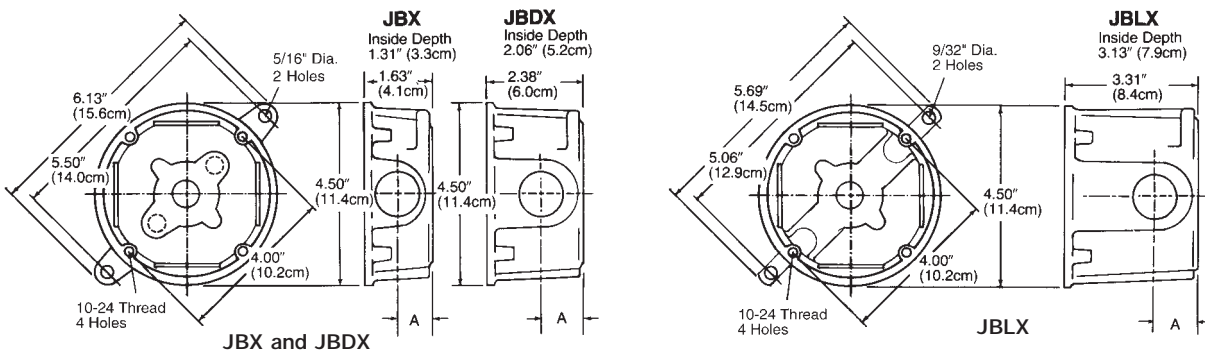

GS Conduit Outlet Boxes, Covers, and Hangers: Malleable Iron

UNILET® for use with Threaded Rigid Metal Conduit and IMC.

Features

- Raintight when enclosed and gasketed with hub or blank covers.
- Extra wide mating surfaces of GS box and cover provide greater gasket contact for more positive seal.
- For exposed or concealed use.
- GSU-20 will take connection block.
- Universal design—furnished with 4 threaded universal 3/4" hubs, four 3/4" to 1/2" reducers, and 3 close-up plugs.
- Furnished with mounting lugs.
- Cushion fixture hangers enclosed and gasketed (vaportight).

Standard Materials

- *Conduit outlet boxes, covers and fixture hangers:* malleable iron.
- *Gaskets:* Neoprene or composition fiber.

Standard Finishes



- *Malleable iron conduit outlet boxes, fixture hangers hub covers:* triple-coat — (1) zinc electroplate, (2) dichromate and (3) epoxy powder coat.
- *1/2" hub and blank covers:* (1) zinc electroplate, (2) dichromate and (3) epoxy powder coat.

Compliances

- UL Standard 514A.
- Federal Spec. W-C-586B.
- Suitable for classified location use in Class I, Division 2 areas, if installed in compliance with NEC 501-4(b).
- Appleton malleable iron conforms to ASTM A47-77, Grade 32510.
- Appleton aluminum products are produced from a high strength copper-free (4/10 of 1% max.) alloy.



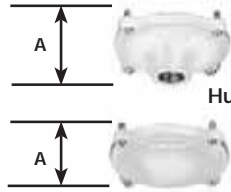

GS conduit outlet box. Four tapped conduit entrances.

| | | Description | Hub Size (Inches) | Length (A) | Catalog Number |
|---|---|--|-------------------|---------------|----------------|
|  GSU-20 GSU-100 | GS — 1-3/4" inside depth, with mounting lugs (Form 20) | | | | |
| | Four threaded universal 3/4" hubs, four 3/4" to 1/2" reducers, and three 1/2" close-up plugs. | | 1/2 or 3/4 | — | GSU-20 |
| | | Four 1" threaded openings and three 1" close-up plugs. | 1 | — | GSU-100 |
|  Hub Cover Blank Cover | GS — Cast Covers | | | | |
| | Furnished with gasket and screws. | | | | |
| | Enclosed and gasketed for raintight fit, supports 250 lbs. | | | | |
| Hub Cover | | | 1/2 | 1.75" (4.4cm) | GSK-50-20 |
| Blank Cover | | | 3/4 | 1.75" (4.4cm) | GSK-75-20 |
| Blank Cover | | | Blank | 1.06" (2.6cm) | GSK-BC-20 |
|  | GS — Cover, Lamp Receptacle | | | | |
| | Furnished with gasket and screws. | | — | 1.63" (4.1cm) | GSK-LR20 |

A-36

GS Conduit Outlet Boxes, Covers, and Hangers: Malleable Iron

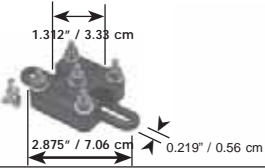
UNILET® for use with Threaded Rigid Metal Conduit and IMC.

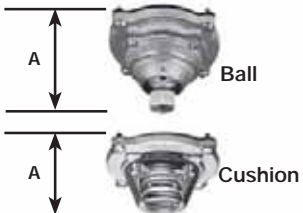
| Description | Hub Size (Inches) | Length (A) | Catalog Number |
|---|-------------------|--|--|
|  <p>GS-20 — Connection Block</p> <p>Furnished with mounting screws. 5-Wire, 20-Amp, 300 Volt</p> | — | — | CB205 |
|  <p>GS — Gasket, Neoprene</p> | — | — | GS-GK20-R |
|  <p>GS — Flexible Fixture Hangers — Form 20</p> <p>Furnished with gasket and screws.</p> <p>Ball Type — 15° swing in all directions, support 250 lbs.</p> <p>Cushion Type, enclosed and gasketed — 8° swing in all directions. Cushions 40 lbs., supports 250 lbs.</p> | — — | 3.00" (7.6cm) 3.25" (8.2cm) 2.00" (5.0cm) 2.00" (5.0cm) | GSK-50-20B GSK-75-20B GSK-50-20C GSK-75-20C |

Dimensions

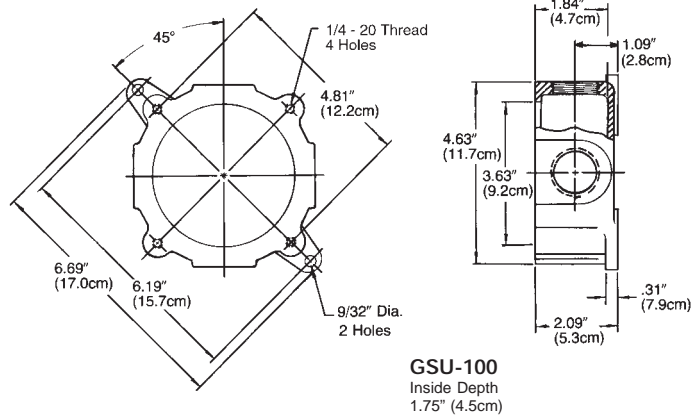
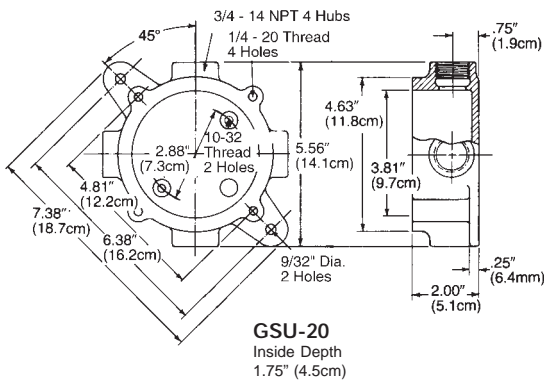

GS Malleable Iron Boxes*

CAPACITY IN CUBIC INCHES

| Hub Size (In.) | GSK Covers | |
|----------------|------------|-----------|
| | GS | Hub Blank |
| 1/2 | 24.0 | 8.5 |
| 3/4 | 24.0 | 8.5 |
| 1 | 24.0 | 8.5 |

Effective September, 2005
Copyright 2005



800-621-1506
www.appletonelec.com

SEH Conduit Outlet Boxes and Covers: Malleable Iron

UNILETS® for use with Threaded Rigid Metal Conduit and IMC.
SEH Boxes Take Wiring Devices Designed
for 4" Octagonal Outlet Boxes.

NOTE: Refer to page A-31 for Wiring Capacity Tables.

Features

- Economy cast conduit outlet box.
- Take wiring devices designed for 4" octagonal outlet boxes.
- Two 8-32 screw holes tapped on 3-1/2" centers.

Standard Materials

- *Conduit outlet boxes and covers:* malleable iron.
- *Gaskets:* Neoprene or composition fiber.

Standard Finishes

- *Malleable iron conduit outlet boxes, and hub covers:* triple-coat — (1) zinc electroplate, (2) dichromate and (3) epoxy powder coat.
- *Blank cast cover:* (1) zinc electroplate, (2) dichromate and (3) epoxy powder coat.
- *Blank steel cover:* zinc electroplate.

Compliances

- UL Standard 514A.
- Federal Spec. W-C-586B.
- Suitable for classified location use in Class I, Division 2 areas, if installed in compliance with NEC 501-4(b).
- Appleton malleable iron conforms to ASTM A47-77, Grade 32510.
- Appleton aluminum products are produced from a high strength copper-free (4/10 of 1% max.) alloy.

| | Description | Hub Size (Inches) | Catalog Number |
|---|--|-------------------|--------------------|
|  | SEH | 1/2 3/4 | SEH-50 SEH-75 |
|  | SEHC | 1/2 3/4 | SEHC-50 SEHC-75 |
|  | SEHL | 1/2 3/4 | SEHL-50 SEHL-75 |
|  | SEHT | 1/2 3/4 | SEHT-50 SEHT-75 |
|  | SEHX | 1/2 3/4 | SEHX-50 SEHX-75 |
|  | SEH—Covers Furnished with screws. | | |
| | Hub Cover, cast malleable | 1/2 | SEHK-50 |
| | Cover, steel | Blank | SEHK-B |
| | Cover, cast malleable | Blank | SEHK-BC |
|  | SEH—Gasket | | SEH-GK |
| | Fiber Composition | | |

Dimensions

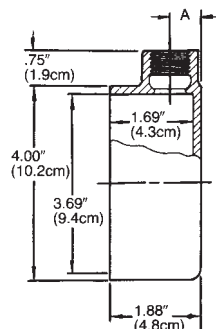
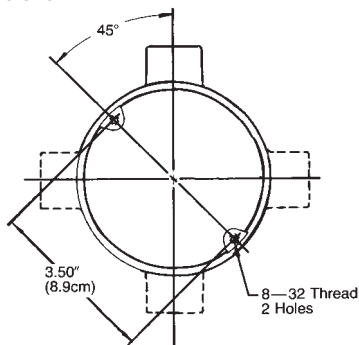

| Hub Size (Inches) | A (Inches) | A (Centimeters) |
|-------------------|------------|-----------------|
| 1/2 | .63 | 1.6 |
| 3/4 | .75 | 1.9 |

CAPACITY IN CUBIC INCHES

| Hub Size (In.) | SEH |
|----------------|------|
| 1/2 | 18.0 |
| 3/4 | 18.0 |

*SEH covers add no additional cubic inch capacity.

Pull Boxes with Threaded Hubs and Covers

For use with Threaded Rigid Metal Conduit and IMC.

Applications

- Serve as pulling fittings.
- Provide openings for splicing.
- Make straight connections and 90° bends in conduit runs.
- Permit access to conductors for maintenance.

Features

- Roomy interiors, more wiring space.
- Accurately tapped, tapered threads (NPT) for tight, rigid joints and ground continuity.

Standard Materials

- Bodies and covers— steel.
- Hubs— malleable iron or steel.
- Cover bolts— stainless steel.

Standard Finish

- Zinc electroplate, dichromate and epoxy powder coat.

Size Range

- Straight Type PTC— 1" thru 6" (hub sizes, 12" thru 48" lengths).

Options

- Custom lengths up to 72" available, consult factory.

Compliances

- UL Standard 514A.

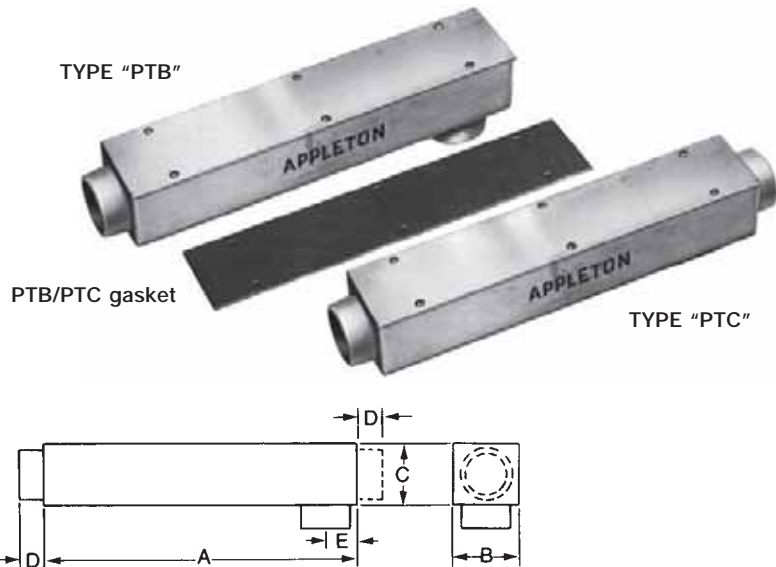

| Catalog Numbers | | Gaskets for PTC & PTB | Hub Size (In.) | Pull Box Dimensions (Inches) | | | | |
|------------------|-------------|-----------------------|----------------|------------------------------|---------|--------|---------|---------|
| Straight PTC Box | 90° PTB Box | | | A | B | C | D | E |
| 12-inch | | | | | | | | |
| 1200 | 1250 | GK-12-100 | 1 | 12 | 2-3/16 | 2-1/8 | 27/32 | 15/16 |
| 1201 | 1251 | GK-12-150 | 1-1/4 | 12 | 2-1/2 | 2-7/16 | 1-1/16 | 1-5/32 |
| 1202 | 1252 | GK-12-150 | 1-1/2 | 12 | 2-1/2 | 2-7/16 | 1-1/16 | 1-3/8 |
| 1203 | 1253 | GK-12-200 | 2 | 12 | 3-11/32 | 3-5/16 | 1-5/16 | 1-11/16 |
| 18-inch | | | | | | | | |
| 1211 | — | GK-18-150 | 1-1/4 | 18 | 2-1/2 | 2-7/16 | 1-1/16 | 1-5/32 |
| 1212 | — | GK-18-150 | 1-1/2 | 18 | 2-1/2 | 2-7/16 | 1-1/16 | 1-3/8 |
| 1213 | — | GK-18-200 | 2 | 18 | 3-11/32 | 3-5/16 | 1-5/16 | 1-11/16 |
| 1214 | — | GK-18-250 | 2-1/2 | 18 | 4-13/16 | 4-3/4 | 1-19/32 | 1-13/16 |
| 24-inch | | | | | | | | |
| 1222 | 1272 | GK-24-150 | 1-1/2 | 24 | 2-1/2 | 2-7/16 | 1-1/16 | 1-3/8 |
| 1223 | 1273 | GK-24-200 | 2 | 24 | 3-11/32 | 3-5/16 | 1-5/16 | 1-11/16 |
| 1224 | 1274 | GK-24-300 | 2-1/2 | 24 | 4-13/16 | 4-3/4 | 1-19/32 | 1-13/16 |
| 1225 | 1275 | GK-24-300 | 3 | 24 | 4-13/16 | 4-3/4 | 1-21/32 | 2-1/16 |
| 36-inch | | | | | | | | |
| 1244 | 1294 | GK-36-300 | 2-1/2 | 36 | 4-13/16 | 4-3/4 | 1-19/32 | 1-13/16 |
| 1245 | 1295 | GK-36-300 | 3 | 36 | 4-13/16 | 4-3/4 | 1-21/32 | 2-1/16 |
| 1246 | 1296 | GK-36-400 | 3-1/2 | 36 | 6-5/16 | 6-3/16 | 1-29/32 | 2-3/8 |
| 1247 | 1297 | GK-36-400 | 4 | 36 | 6-5/16 | 6-3/16 | 1-29/32 | 2-21/32 |
| 48-inch | | | | | | | | |
| 1812 | — | GK-48-300 | 3 | 48 | 4-13-16 | 4-3/4 | 1-21/32 | 2-1/16 |
| 1813 | — | GK-48-400 | 3-1/2 | 48 | 6-5/16 | 6-3/16 | 1-29/32 | 2-3/8 |
| 1814 | — | GK-48-400 | 4 | 48 | 6-5/16 | 6-3/16 | 1-29/32 | 2-21/32 |
| 1815 | — | GK-48-500 | 5 | 48 | 7-5/16 | 7-3/16 | 1-27/32 | 3-1/4 |
| 1816 | — | GK-48-600 | 6 | 48 | 8-5/16 | 8-3/16 | 2-1/32 | 4-1/32 |

Big-Bend™ Cast Pulling Elbow

For use with Threaded Rigid Metal Conduit and IMC.

Application

● Big-Bend™ Pulling Elbow is installed in conduit systems to provide 90° bends in conduit runs, pull outlets for conductors, access to conductors for maintenance and openings for making splices.

Features

- Cast from copper-free aluminum.
- Composition gasket in cover.
- Stainless steel cover bolts.
- Plugged 1/2" outlets top and bottom for breather and drain.
- Available in cast iron.
- Allows bending radius of 8 to 12 times outside diameter of conductor.
- Conductors can be pulled straight through.
- Cover easily installed.

Standard Materials

- Bodies and covers: copper-free aluminum.
- Gaskets: composition.
- Cover bolts: stainless steel.

Standard Finishes

- Acrylic paint.

Compliances

- Certification Standard C22.2 No. 18-M1987 NEMA 4.
- UL Standard 514A.



Conduit Systems Installations



A-40

Big-Bend™ Cast Pulling Elbow Conduit Systems Installations

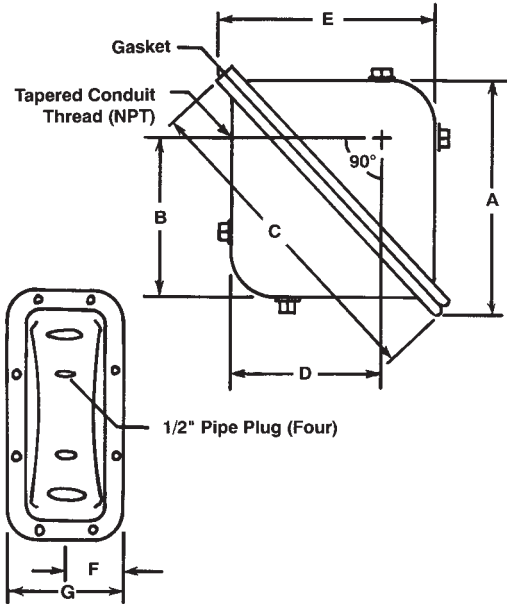
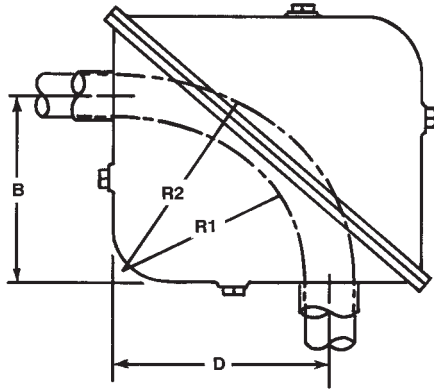

BENDING RADII OF BIG-BEND PULLING ELBOW

| Catalog Number | Conduit Size (In.) | R1 (In.) | R2 (In.) | R1 (Cm) | R2 (Cm) |
|----------------------|--------------------|----------|----------|---------|---------|
| BB1-050 | 1/2 | 8.187 | 8.812 | 20.79 | 22.38 |
| BB1-075 | 3/4 | 8.062 | 8.875 | 20.48 | 22.54 |
| BB1-100 | 1 | 7.875 | 8.937 | 20.00 | 22.70 |
| BB1-125 | 1-1/4 | 7.812 | 9.250 | 19.84 | 23.50 |
| BB1-150 | 1-1/2 | 7.687 | 9.312 | 19.52 | 23.65 |
| BB1-200 | 2 | 7.437 | 9.500 | 18.89 | 24.13 |
| BB1-250 | 2-1/2 | 7.250 | 9.687 | 18.42 | 34.60 |
| BB1-300 | 3 | 6.875 | 9.937 | 17.46 | 25.24 |
| BB1-350 | 3-1/2 | 6.687 | 10.250 | 16.98 | 26.04 |
| BB1-400 | 4 | 6.437 | 10.500 | 16.35 | 26.67 |
| BB2-075 | 3/4 | 12.937 | 13.750 | 32.86 | 34.93 |
| BB2-100 | 1 | 12.750 | 13.812 | 32.39 | 35.08 |
| BB2-125 | 1-1/4 | 12.687 | 14.125 | 32.22 | 35.88 |
| BB2-150 | 1-1/2 | 12.562 | 14.187 | 31.91 | 36.03 |
| BB2-200 | 2 | 12.312 | 14.375 | 31.27 | 36.51 |
| BB2-250 | 2-1/2 | 12.125 | 14.562 | 30.80 | 36.99 |
| BB2-300 | 3 | 11.750 | 14.812 | 29.85 | 37.62 |
| BB2-350 | 3-1/2 | 11.562 | 15.125 | 29.37 | 38.42 |
| BB2-400 | 4 | 11.312 | 15.375 | 28.73 | 29.05 |
| BB3-050 | 1/2 | 13.062 | 13.687 | 33.18 | 34.76 |
| BB3-075 | 3/4 | 12.937 | 13.750 | 32.86 | 34.93 |
| BB3-100 | 1 | 12.750 | 13.812 | 32.39 | 35.08 |
| BB3-125 | 1-1/4 | 12.687 | 14.125 | 32.22 | 35.88 |
| BB3-150 | 1-1/2 | 12.562 | 14.187 | 31.91 | 36.03 |
| BB3-200 | 2 | 12.312 | 14.375 | 31.27 | 36.51 |
| BB3-250 | 2-1/2 | 12.125 | 14.562 | 30.80 | 36.99 |
| BB3-300 | 3 | 11.750 | 14.812 | 29.85 | 37.62 |
| BB3-350 | 3-1/2 | 11.562 | 15.125 | 29.37 | 38.42 |
| BB3-400 | 4 | 11.312 | 15.375 | 28.73 | 39.05 |
| BB3-500 | 5 | 10.812 | 15.812 | 27.46 | 40.16 |
| BB3-600 | 6 | 10.312 | 16.375 | 26.19 | 41.59 |
| Size | BB1 | BB2 | BB3 | | |
| Inside Dimensions | 12x12x6 | 18x18x6 | 18x18x8 | | |
| Approx. Shp. Wt/Unit | 18lbs. | 32 lbs. | 48 lbs. | | |

| | Dimensions In Inches | | |
|---|----------------------|--------|--------|
| | BB1 | BB2 | BB3 |
| A | 12-3/4 | 19-7/8 | 19-7/8 |
| B | 9 | 14 | 14 |
| C | 18-3/4 | 27-1/4 | 27-1/2 |
| D | 9 | 14 | 14 |
| E | 12-3/4 | 19-7/8 | 19-7/8 |
| F | 3-7/8 | 3-7/8 | 5 |
| G | 7-3/4 | 7-3/4 | 10 |

| | Dimensions In Centimeters | | |
|---|---------------------------|-------|-------|
| | BB1 | BB2 | BB3 |
| A | 32.39 | 50.48 | 50.48 |
| B | 24.48 | 38.10 | 35.56 |
| C | 47.63 | 69.22 | 69.85 |
| D | 24.48 | 38.10 | 35.56 |
| E | 34.93 | 50.48 | 50.48 |
| F | 9.84 | 9.84 | 12.70 |
| G | 19.69 | 19.69 | 25.40 |

| Conduit Size (In.) | Code | Conduit Size (In.) | Code |
|--------------------|------|--------------------|------|
| 1/2 | 050 | 2-1/2 | 250 |
| 3/4 | 075 | 3 | 300 |
| 1 | 100 | 3-1/2 | 350 |
| 1-1/4 | 125 | 4 | 400 |
| 1-1/2 | 150 | *5 | 500 |
| 2 | 200 | *6 | 600 |

* Available in Big-Bend™ Size 3 only

