

**PRODUCT LINE**

**TABLE OF CONTENTS**

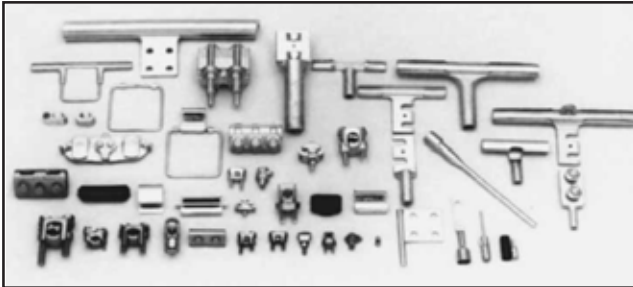

**TAP CONNECTORS**

Mechanical (Bolted) . . . . . H-3 - H-17  
 Compression . . . . . H-18 - H-37  
 Transformer and Equipment. . . . . H-38 - H-40

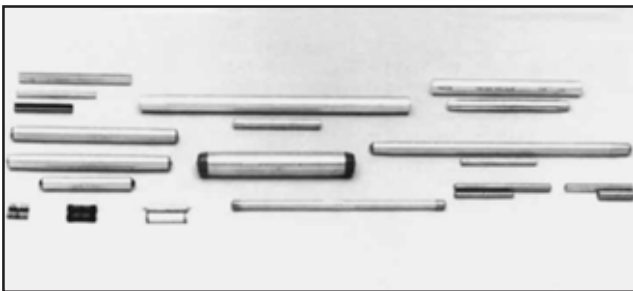

**COMPRESSION SPLICES**

Service Entrance . . . . . H-42 - H-45  
 Neutral . . . . . H-46  
 Jumper . . . . . H-47 - H-51  
 Repair Sleeve . . . . . H-51 - H-52  
 Full Tension . . . . . H-53 - H-63

H-1



**DEADEND FITTING AND ACCESSORIES**

Loop . . . . . H-65 - H-66  
 Primary and Strain Bus . . . . . H-67 - H-68

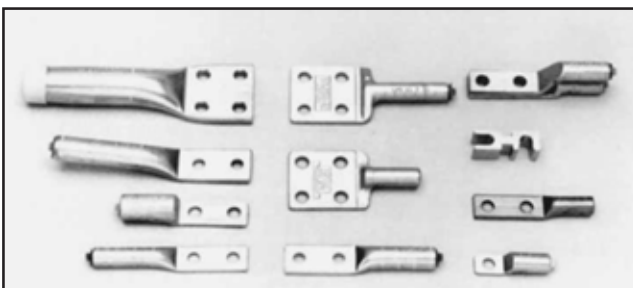

**COMPRESSION TERMINALS**

**AND ACCESSORIES. . . . . H-69 - H-75**

Blue highlighted items are industry standard and most frequently ordered.

## TAP CONNECTORS

### TABLE OF CONTENTS

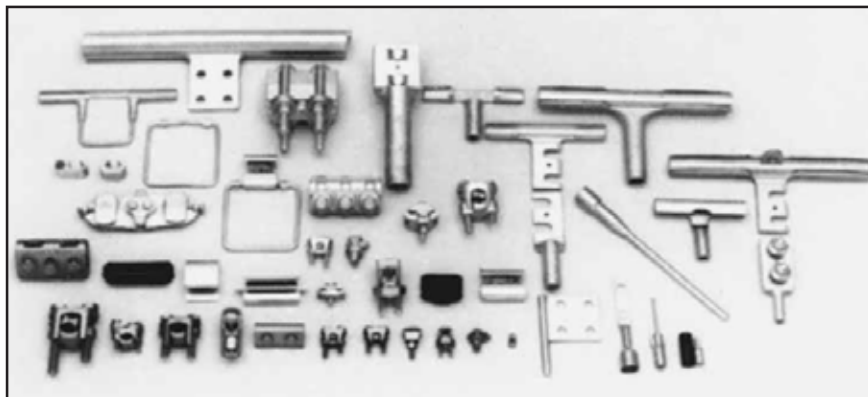

#### MECHANICAL (BOLTED)

Mechanical Tap Connectors	H-3
Types <b>KS &amp; KS-3</b>	H-4
Type <b>SC</b>	H-4
Type <b>KSU</b>	H-5
Type <b>KVS</b>	H-5
Type <b>KVSW</b>	H-6
Types <b>KVSU &amp; KVS</b>	H-7
Type <b>KVS-A</b>	H-8
Types <b>UC-L, UC-K</b>	H-9
Type <b>CP-A</b>	H-10
Type <b>VP</b>	H-11
Type <b>UW-R</b>	H-11
Type <b>UC</b>	H-12
Type <b>CP</b>	H-12
Type <b>QPX</b>	H-13
Type <b>VT</b>	H-14
Types <b>UCG-R &amp; UCG-RS</b>	H-15
Types <b>UC-R &amp; UC-RS</b>	H-15
Types <b>UC KIT &amp; UCCOVER1</b>	H-16
Type <b>LSC</b>	H-17

#### COMPRESSION

Compression Tap Connectors	H-18
Type <b>YC-C</b>	H-19
Type <b>YP-C</b>	H-19
Type <b>YC-A</b>	H-20
Types <b>YP-U, YPC-U</b>	H-21
Type <b>YPC-U</b>	H-22
Type <b>YC-U</b>	H-23

Types <b>YPC-A-U &amp; YPC-R-U</b>	H-23
Type <b>CC</b>	H-24
Seven Connector Selector Chart	H-25
Types <b>YHO &amp; YHD</b>	H-26
Types <b>YHN &amp; YHR</b>	H-27
<b>LOKTAP™</b>	H-28
Type <b>YCT</b>	H-29
Type <b>YOT</b>	H-29
Type <b>YTU-R-R</b>	H-30
Type <b>YTA-R-2N</b>	H-31
Types <b>YKA-R-2N &amp; YKA-A-2N</b>	H-32
Type <b>YSA-R-2N</b>	H-33
Type <b>YTA-2N</b>	H-33
Type <b>YKA-2N</b>	H-34
Type <b>YCB-R</b>	H-35
Types <b>YCB-U &amp; YCB-R-U</b>	H-36
Types <b>J990 &amp; J1252</b>	H-36
Types <b>YHO-J, YHD-J, YHN-J</b>	H-37

#### TRANSFORMER AND EQUIPMENT

Type <b>E-C-G</b>	H-38
Types <b>KC2 &amp; EQC632C</b>	H-39
Type <b>YA-2LH</b>	H-39
Type <b>YE-LH</b>	H-40
Type <b>YE-R, YE-W</b>	H-40

Blue highlighted items are industry standard and most frequently ordered.

## MECHANICAL (BOLTED) TAP CONNECTORS

BURNDY’s line of mechanical tap connectors is the most complete, dependable and economical available. These mechanical connectors consist of service, parallel, and midspan types.

Generally the alloys and hardware used depend on whether the connector is for a strain or current carrying application, and is made of aluminum or copper. Particular alloys and hardware are selected for strength, conductivity, durability, ductility and resistance to corrosion.

In a copper connector high strength alloys are used in mechanical clamping components and high conductivity alloy in current carrying elements.

Aluminum clamp type connectors are made of alloy 356, which is impervious to stress corrosion. In its heat-treated state, it has high strength and is used for both current carrying and clamping elements.

Hardware is high strength and corrosion-resistant. In copper connectors, DURIUM™, a silicone bronze alloy, is used. Anodized aluminum alloy 2024-T4 bolts and 6061-T6 nuts are used in aluminum connectors. They provide the best combination of strength, resistance to galling and corrosion, and their thermal coefficient of expansion is most suitable for aluminum. To insure dependable connections, bolts should be tightened to the recommended torque values shown below.

These mechanical tap connectors are mainly used in overhead distribution systems to provide primary service taps and/or secondary service drop connections to the end users.

A few of the key features and benefits of these connectors are:

### Features and Benefits

- High strength alloys.
  - ◇ Provides efficient and reliable performance.
- Range taking.
  - ◇ Accommodates a large range of conductors in either groove reducing inventory to a minimum.
- Matched groove designs.
  - ◇ Ensures maximum contact with conductors accommodated.
- Hex bolts, nuts and washers.
  - ◇ Provides high contact pressure and rapid assembly.

H-3

Recommended Tightening Torque		Standard Wrench Size	
Bolt Size	Recommended Torque (Inch Lbs.)	Bolt	Nut
<b>DURIUM™ and Galvanized Hardware</b>			
1/4 - 20	80	7/16	7/16
5/16 - 18	180	1/2	1/2
3/8 - 16	240	9/16	9/16
1/2 - 13	480	3/4	3/4
5/8 - 11	660	15/16	15/16
3/4 - 10	1050	1-1/8	1-1/8
<b>Aluminum Hardware*</b>			
1/2 - 13	300	3/4	3/4
5/8 - 11	480	15/16	15/16
3/4 - 10	650	1-1/8	1-1/8

\* Aluminum bolts are lubricated.

Blue highlighted items are industry standard and most frequently ordered.

## TYPES KS & KS-3

### SERVIT®

For Copper, Copperweld

Compact, high strength, high copper alloy SERVIT® split-bolt has free-running threads and easy to grip wrench flats. Highly resistant to season cracking and corrosion, the SERVIT® provides maximum pressure and assures a secure connection on all combinations of run and tap conductors. Type KS-3 accommodates 3 maximum size conductors.

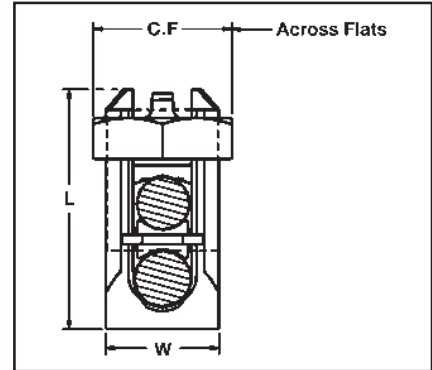

H-4

Catalog Number	Cross Flats	L	W	Conductor						Recommended Tightening Torque in-lb
				Copper		Copperweld				
				Range for Equal Run and Tap	Min. Tap with Max. Run	Maximum Run and Tap		Type A	Type D	
† KS90	.50	.85	.38	12 Str. - 10 Str.	16 Str.	#10	—	—	—	80
† KS15	.50	.85	.38	10 Str. - 8 Str.	14 Str.	#8	—	—	—	
† KS17	.63	1.14	.45	8 Str. - 6 Sol.	14 Str.	#6	3 #12	8A	9-1/2D	
* KS17-3				8 Str. - 6 Sol.	16 Str.	#6	3 #12	8A	9-1/2D	165
† KS20	.69	1.20	.51	8 Str. - 4 Sol.	14 Str.	#4	3 #10	6A	8D	
* KS20-3				8 Str. - 4 Sol.	14 Str.	#4	3 #10	6A	8D	
† KS22	.75	1.50	.60	6 Str. - 2 Sol.	14 Str.	#2	3 #8	4A	6D	275
* KS22-3				6 Str. - 2 Sol.	14 Str.	#2	3 #8	4A	6D	
† KS23	.82	1.54	.62	6 Str. - 2 Str.	14 Str.	#1	3 #7	3A	5D	
† KS25	.94	1.77	.73	4 Str. - 1/0 Str.	14 Str.	2/0	3 #5	2A	4D	385
† KS26	1.05	1.94	.82	2 Str. - 2/0 Str.	14 Str.	3/0	7 #7	—	—	
† KS27	1.36	1.86	1.17	1 Str. - 3/0 Str.	8 Sol.	—	—	—	—	
† KS29	1.36	2.07	1.17	1 Str. - 250	8 Str.	4/0	7 #5	—	—	650
† KS31	1.70	2.51	1.41	1/0 Str. - 350	1/0 Str.	—	19 #8	—	—	
† KS34	1.82	2.79	1.48	2/0 Str. - 500	2/0 Str.	—	19 #6	—	—	
KS39	2.31	3.29	1.94	4/0 Str. - 750	4/0 Str.	—	19 #5	—	—	1000
KS44	2.56	3.73	2.19	300 - 1000	4/0 Str.	—	—	—	—	1100

▲ Listed torque values are for maximum conductor combinations accommodated. Consult UL486 Tables 7-4, 7-5, 7-6 for smaller conductor combinations.

See note page A-2  
\* Not UL Listed or CSA Certified.

† In addition to UL Listed for wire connectors and CSA Certified, these items are also UL rated for direct burial.

## TYPE SC

### SERVIT® COVER

### HUG-A-BUG

Used indoors or outdoors this compact, one-piece plastic SERVIT® cover, saves time and material, eliminates costly taping of split-bolts. Positive latch snaps easily and quickly over connector, ideal for tight quarters. Self positioning plastic fingers wrap around wires fully insulating joint. UL listed for 600 volt indoor application. Three covers accommodate a range of 6 SERVIT® sizes through 2/0 Str.



Catalog Number	Conductor Range				*For Use with	For Use with
	Range for Equal Run and Tap		Min. Tap with Max. Cable Run			
	Min.	Max.	Min.	Max.		
SC4	8 Str.	6 Sol.	14 Str.	6 Sol.	KS17	—
SC4	8 Str.	4 Sol.	14 Str.	4 Sol.	KS20	—
SC2	6 Str.	2 Sol.	14 Str.	2 Sol.	KS22	KSA6
SC2	6 Str.	2 Str.	14 Str.	2 Str.	KS23	KSA4
SC2/0	4 Str.	1/0 Str.	14 Str.	1/0 Str.	KS25	KSA2
SC2/0	2 Str.	2/0 Str.	14 Str.	2/0 Str.	KS26	KSA1/0

\* UL listing of Type SC Cover applies to use on BURNDY® SERVIT® Type KS and to equivalent split-bolt connectors indicated strip length is maintained, maximum indicated

conductor sizes are not exceeded, and connector is properly located within recess provided for it.

Blue highlighted items are industry standard and most frequently ordered.

**TYPE KSU**

**UNIVERSAL SERVIT®**

For All Combinations of Copper, Aluminum, ACSR, AAAC, 5005, & Steel

Tin-plated, high strength copper alloy SERVIT® with spacer. Spacer separates dissimilar conductors and provides long contact length that prevents high pressure point contacts between run and tap conductors.

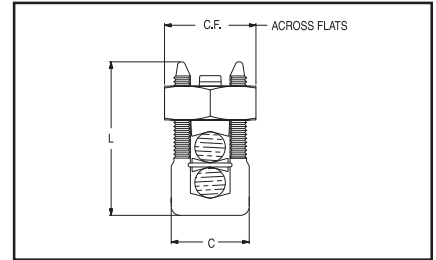

Use of PENETROX™ joint compound recommended with aluminum or ACSR.



Catalog Number	Cross Flat	L	W	Conductor				Maximum Conductor Steel Sol. 3 Str. Nom. BWG BWG Dia.	Recommended Tightening Torque in.-lb.
				Run		TAP			
				Copper & Aluminum	ACSR, AAAC, 5005	Copper & Aluminum	ACSR, AAAC, 5005		
<b>KSU17</b>	.62	.92	.70	12 Sol. - 6 Sol.	8 (6 - 1)	12 Sol. - 6 Sol.	8 (6 - 1)	8 — 5/32	
<b>KSU20</b>	.69	1.05	.78	10 Sol. - 4 Sol.	6 (6 - 1)	10 Sol. - 4 Sol.	6 (6 - 1)	6 8 7/32	165
<b>KSU22</b>	.74	1.25	.84	10 Sol. - 2 Sol.	6 (6 - 1) - 4 (7 - 1)	10 Sol. - 2 Sol.	6 (6 - 1) - 4 (7 - 1)	4 6 1/4	275
<b>KSU23</b>	.81	1.48	.94	8 Str. - 2 Str.	3 (6 - 1) - 2 (6 - 1)	8 Sol. - 2 Str.	6 (6 - 1) - 2 (6 - 1)	— 4 5/16	275
<b>KSU25</b>	.93	1.77	1.06	2 Str. - 1/0 Str.	3 (6 - 1) - 1 (6 - 1)	10 Str. - 1/0 Str.	6 (6 - 1) - 1 (6 - 1)	— — 3/8	385
<b>KSU26</b>	1.04	1.93	1.19	1/0 Str. - 2/0 Str.	1 (6 - 1) - 1/0 (6 - 1)	8 Str. - 2/0 Str.	6 (6 - 1) - 1/0 (6 - 1)	— — 7/16	385
<b>KSU27</b>	1.38	2.34	1.58	1 Str. - 3/0 Str.	1 (6 - 1) - 2/0 (6 - 1)	8 Sol. - 3/0 Str.	8 (6 - 1) - 2/0 (6 - 1)	— — 1/2	500
<b>KSU29</b>	1.38	2.50	1.58	1 Str. - 250	2/0 (6 - 1) - 4/0 (6 - 1)	8 Str. - 250	6 (6 - 1) - 4/0 (6 - 1)	— — 1/2	650
<b>KSU31</b>	1.69	2.88	1.91	4/0 Str. - 350	3/0 (6 - 1) - 4/0 (6 - 1)	4 Str. - 350	4 (6 - 1) - 4/0 (6 - 1)	— — 5/8	650
<b>KSU34</b>	2.00	3.12	2.28	400 - 500	336 (30 - 7) - 477 (18 - 1)	2 Str. - 500	2 (6 - 1) - 477 (18 - 1)	— — —	825

H-5

**TYPE KVS**

**OKLIP™**

Mechanical Connector for Copper and Copperweld

Compact, two-piece, high strength; high copper alloy BURNDY® OKLIP™ recommended for heavy duty connections. Neoprene rings hold bolts in place during installation. Installed with ordinary wrench.



Catalog Number	Conductor				
	Copper		Copperweld		
	Run	Tap	Sol.	Str.	Type V
<b>KVS26</b>	1 Str. - 2/0 Str.	6 Str. - 2/0 Str.	3/0	7 #8	—
<b>KVS28</b>	1/0 Str. - 4/0 Str.	10 Str. - 4/0 Str.	4/0	7 #6	V3/0
<b>KVS31</b>	250 - 350	10 Str. - 350	—	19 #8	V250
<b>KVS34</b>	400 - 500	10 Str. - 500	—	19 #6	V350
<b>KVS40</b>	400 - 800	3/0 Str. - 800	—	19 #5	—
<b>KVS44</b>	500 - 1000	3/0 Str. - 1000	—	—	—

Blue highlighted items are industry standard and most frequently ordered.

## TYPE KVSW

### OKLIP™

Mechanical Connector for Copper and Copperweld

Similar to OKLIP™ Type KVS except for high copper alloy spacer that separates run and tap conductor. Provides high contact pressure, confines conductor strands, and assures vibration proof connection. Longer peened bolt, permits swivel action for easier installation.



Catalog Number	Conductor	
	Run	Tap
<b>KVSW26</b>	2 Str. - 2/0 Str.	6 Sol. - 2/0 Str.
<b>KVSW28</b>	1/0 Str. - 4/0 Str.	6 Sol. - 4/0 Str.
<b>KVSW31</b>	250 - 350	4 Sol. - 350
<b>KVSW34</b>	400 - 500	4 Str. - 500
<b>KVSW40</b>	400 - 800	4/0 - 800
<b>KVSW44</b>	500 - 1000	250 - 1000

Blue highlighted items are industry standard and most frequently ordered.

**TYPES KVSU, KVS**

**UNIVERSAL OKLIP™**

Mechanical Connector for All Combinations of Copper, Aluminum†, ACSR†, AAAC and 5005

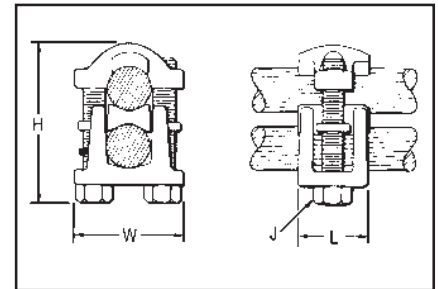

Compact, tin-plated, high strength, high copper alloy two-piece connector with spacer and tin-plated silicone bronze DURIMUM™ hardware. Recommended for heavy duty connections. Spacer separates dissimilar conductors and provides long contact length. Neoprene ring prevents loss of shorter bolt during installation. Longer peened bolt, permits swivel action for easier installation.

Use of PENETROX™ joint compound recommended with aluminum and ACSR.

H-7

Catalog Number	Conductor			
	Run		Tap	
	Copper & Aluminum†	ACSR†, AAAC, & 5005	Copper & Aluminum†	ACSR†, AAAC, & 5005
KVSU26	2 Str. - 2/0 Str.	3 - 2/0	6 Str. - 2/0 Str.	6 - 2/0
KVSU28	1/0 Str. - 4/0 Str.	1/0 - 4/0	6 Str. - 4/0 Str.	6 - 4/0
KVSU31	250 - 350	4/0 - 300	5 - 350	6 - 300
KVSU34	400 - 500	336.4 - 397.5	4 - 500	5 - 397.5
KVSU40	400 - 800	336.4 - 715.5	4/0 - 800	3/0 - 715.5
KVSU44	500 - 1000	397.5 - 900	4/0 - 1000	4/0 - 900

† Accommodates compressed conductors within diameter range.

Catalog Number	Conductor				
	Copper		Copperweld		
	Run	Tap	Sol.	Max. Run and Tap	Type V
KVS26	1 Str. - 2/0 Str.	6 Str. - 2/0 Str.	3/0	7 #8	—
KVS28	1/0 Str. - 4/0 Str.	10 Str. - 4/0 Str.	4/0	7 #6	V3/0
KVS31	250 - 350	10 Str. - 350	—	19 #8	V250
KVS34	400 - 500	10 Str. - 500	—	19 #6	V350
KVS40	400 - 800	3/0 Str. - 800	—	19 #5	—
KVS44	500 - 1000	3/0 Str. - 1000	—	—	—

Blue highlighted items are industry standard and most frequently ordered.

**TYPE KVS-A**

**ALUMINUM OKLIP™**

Mechanical Connector for All Combinations of Copper, Aluminum†, ACSR†, AAAC & 5005

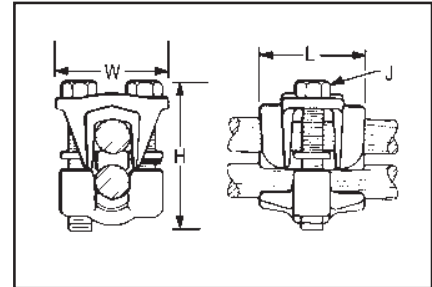

Three-piece, high-conductivity, non-copper bearing aluminum alloy connector with thick spacer and aluminum hardware. Hardware in KVS26A and KVS28A is stainless steel. Recommended for heavy duty dissimilar metal applications. Spacer separates conductors and provides long contact length.

Belted entrances prevent chafing and permit easier assembly of conductors. Longer, peened bolt, permits swivel action for easier installation. Neoprene ring prevents loss of shorter bolt. PENETROX™ joint compound recommended with aluminum and ACSR.

H-8

Catalog Number	Conductor			
	Run		Tap	
	Copper & Aluminum†	ACSR†, AAAC, & 5005	Copper & Aluminum†	ACSR†, AAAC, 5005
KVS26A	2 Str. - 2/0 Str.	4 - 2/0	10 Str. - 2/0 Str.	6 - 2/0
KVS28A	1/0 Str. - 4/0 Str.	1/0 - 4/0	10 Str. - 4/0 Str.	6 - 4/0
KVS31A	250 - 350	4/0 - 336.4	6 Str. - 350	6 - 336.4
KVS34A	400 - 500	336.4 - 397.5	4 Str. - 500	5 - 397.5
KVS40A	400 - 800	336.4 - 715.5	3/0 Str. - 800	3/0 - 715.5
KVS44A	500 - 1000	397.5 - 900	3/0 Str. - 1000	3/0 - 900

† Accommodates compressed conductors within diameter range.

**THESE CONNECTORS CAN ACCOMMODATE ACSR CONDUCTORS OVER ARMOR ROD WITHIN THE DIAMETER RANGE INDICATED.**

Application Over Armor Rod

Catalog Number	Conductor Range by Diameter			H	J	L	W
	Min. Run Dia.	Min. Tap Dia.	Max. Run & Tap Dia.				
KVS26A	.281	.116	.447	2	5/16	1-3/8	1-5/8
KVS28A	.360	.116	.564	2-3/8	3/8	1-5/8	2
KVS31A	.565	.184	.681	3	1/2	2	2-5/8
KVS34A	.728	.216	.814	3-3/8	1/2	2-1/2	2-5/8
KVS40A	.728	.470	1.036	4	1/2	3-1/8	3
KVS44A	.806	.470	1.162	4-1/2	5/8	3-1/2	3-3/8

Blue highlighted items are industry standard and most frequently ordered.



**TYPE UC-L**

**UNIVERSAL PARALLEL CLAMP**

For All Combinations of Copper, Aluminum†, ACSR†, 6201, 5005, Steel and Copperweld

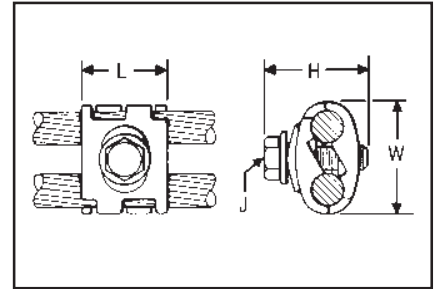

Interlocking finger design accommodates large range of conductor sizes. Tin-plated, cast of high copper alloy and clamped with plated steel bolt, PENETROX™ joint compound recommended with aluminum and ACSR.

Catalog Number	Copper & Alum. (Either Groove)	ACSR†, 6201, 5005	Copperweld	Steel		Installation Tooling		Dimensions			
				Nom. Dia.	AWG	Copper Conductor Size (AWG)	Tightening Torque (in.-lbs.)	L	H	J	W
UC8W26-L	8 Sol. - 2/0 Str.	6 - 1/0	8 Sol. - 7 #7	5/32 - 7/16	8 Sol. - 4-3 Str.	#8	75	1	1-1/2	5/16	1-7/16
*UC2W28-L	2 Sol. - 4/0 Str.	3 - 4/0	3 #8 - 7 #6	9/32 - 9/16	4-3 Str. - 4-3 Str.	#6 - #4	110	1-1/8	1-1/2	3/8	1-3/4

† Accommodates compressed conductors within diameter range.

H-9

**TYPE UC-K**

**UNIVERSAL PARALLEL CLAMP**

For All Combinations of Copper, Aluminum†, ACSR, Steel and Copperweld

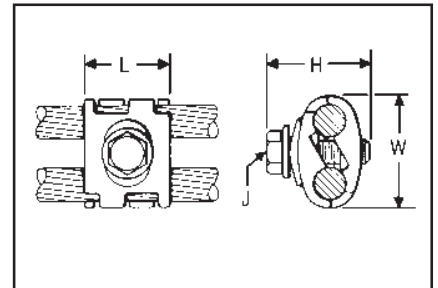

Interlocking finger design accommodates large range of conductor sizes. Tin-plated, cast of high copper alloy and clamped with silicon bronze DURIMUM™ bolt, PENETROX™

joint compound recommended with ACSR. Applications include grounding for the Cable TV industry.



Catalog Number	For Use with:	Conductor Range				Installation Torques		Dimensions			
		Groove A		Groove B		Conductor Size	Torque (in.-lbs.)	L	H	J	W
		Maximum Size	Minimum Size	Maximum Size	Minimum Size						
UCK-1UL†	Aluminum or Galvanized Steel Strand to Copper or Copper Bonded Steel Wire	1/0 ACSR or 7/16 Galvanized Steel Strand	#6 ACSR	2/0 Str. Copper 7/16 Copperweld, 2A Copperweld	#8 Sol. Copper 9-1/2D Copperweld	#8	75				
UCK-2UL	Aluminum or Galvanized Steel Strand to Aluminum or Galvanized Steel Strand	1/0 ACSR or 7/16 Galvanized Steel Strand	#6 ACSR	1/0 ACSR or 7/16 Galvanized Steel Strand	#6 ACSR	#6 - #4	110	1	1-7/16	5/16	1-7/16
UCK-3UL*	Copper to Copper	2/0 Str. Copper 7/16 Copperweld, 2A Copperweld	#8 Sol. Copper 9-1/2D Copperweld	2/0 Str. Copper 7/16 Copperweld 2A Copperweld	#8 Sol. Copper 9-1/2D Copperweld	1/0 - 2/0	150				

† Accommodates compressed conductors within diameter range.

Blue highlighted items are industry standard and most frequently ordered.

## TYPES CP-A

### PARALLEL CLAMP

For All Combinations of Copper, Aluminum†, ACSR†, 6201 & 5005

Type CP-A is recommended for tap or parallel connections. High strength, high conductivity aluminum body and hardware provide corrosion resistant assembly. Long contact surface insures excellent contact and full conductivity. PENETROX™ joint compound recommended for all combinations.

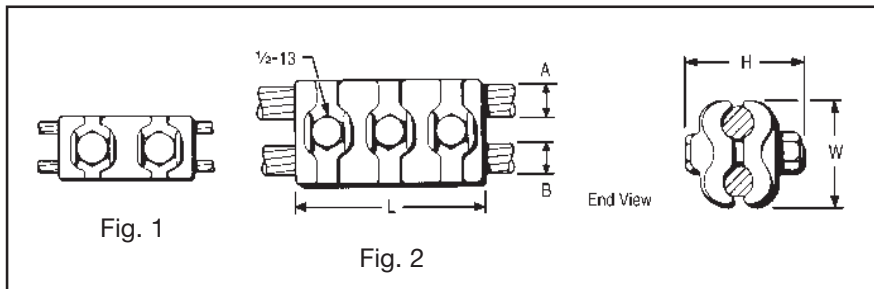

H-10

Catalog Number	Groove A		Groove B		Fig. No.	Dimensions		
	ACSR, 6201, 5005	Copper & Aluminum	ACSR, 6201, 5005	Copper & Aluminum		L	H	W
CP26A26A	1/0	3/0 Sol. - 2/0 Str.	1/0	3/0 Sol. - 2/0 Str.	1	4"	2-7/8"	2-1/8"
CP27A27A	2/0	4/0 Sol. - 3/0 Str.	2/0	4/0 Sol. - 3/0 Str.				
	101.8 (12-7) 110.8 (12-7)		101.8 (12-7) 110.8 (12-7)					
CP28A28A	3/0	4/0 Str.	3/0	4/0 Str.				
	134.6 (12-7)		134.6 (12-7)					
CP29A29A	4/0	250 266.8	4/0	250 266.8				
	159 (12-7) 203 (8-7)		159 (12-7) 203 (8-7)					
CP30A30A	176.9 (12-7) 190.8 (12-7) 266.8 (18-1, 6-7, 26-7)	300	176.9 (12-7) 190.8 (12-7) 266.8 (18-1, 6-7, 26-7)	300	2	4-1/2"	3"	2-3/8"
	211.3 (12-7) 300 (26-7, 30-7) 336.4 (18-1)		211.3 (12-7) 300 (26-7, 30-7) 336.4 (18-1)					
CP31A31A	203.2 (16-19) 336.4 (26-7, 30-7) 397.5 (18-1)	397.5 400	203.2 (16-19) 336.4 (26-7, 30-7) 397.5 (18-1)	450 477 500				
CP32A32A	397.5 (26-7, 30-7) 477 (18-1)		397.5 (26-7, 30-7) 477 (18-1)					
CP34A34A	500 (30-7) 556.5 (24-7, 26-7, 30-7) 636 (36-1) 605 (24-7)	636	500 (30-7) 556.5 (24-7, 26-7, 30-7) 636 (36-1) 605 (24-7)	636	5-1/4"	3-3/8"	3"	
CP37A37A								

† Accommodates compact and compressed conductors within diameter range. For other sizes contact factory.

Blue highlighted items are industry standard and most frequently ordered.

**TYPE VP**

**PARALLEL CLAMP**

For Copper

Multiple V-bolt connector especially suited for flexible or extra flexible conductors. Made of high strength, high conductivity copper. Clamping elements accommodate a range of conductor sizes in either groove. V-bolts provide high pressure and compress the conductor over long contact area. Also recommended for jumper connections.

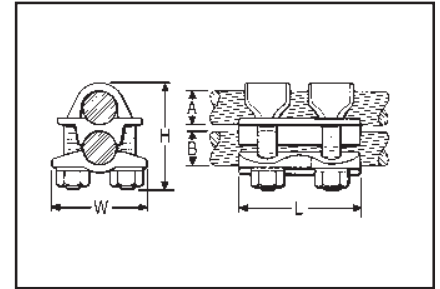

Catalog Number	Groove A	Groove B	Dimensions		
			H	L	W
VP2828	1/0 Str. - 4/0 Str.	1/0 Str. - 4/0 Str.	2-1/8"	2-3/4"	1-3/4"
VP3030	1/0 Str. - 300	1/0 Str. - 300	2-1/2"	3-1/8"	2"
VP3430	300 - 500		3-1/8"	3-1/4"	2-1/2"
VP3434	500 - 800	300 - 500	4-3/8"	3-1/2"	2-7/8"
VP4030		1/0 Str. - 300		3-3/4"	
VP4040	750 - 1000	500 - 800	5"	3-7/8"	3-1/4"
VP4440				3-7/8"	3-1/4"
VP4646	1000 - 1500	1000 - 1500	5-3/8"	4-1/2"	3-1/2"

H-11

**TYPE UW-R**

**CLIPIT™**

Deadend Clamp for Aluminum†, ACSR†, 6201 and 5005

High strength aluminum casting with galvanized steel U-bolt, extra long aluminum spacer, and caps that confine strands. Holding strength of installations using two CLIPIT™ deadends exceeds rated breaking strength of conductor. Use of PENETROX™ joint compound is recommended.

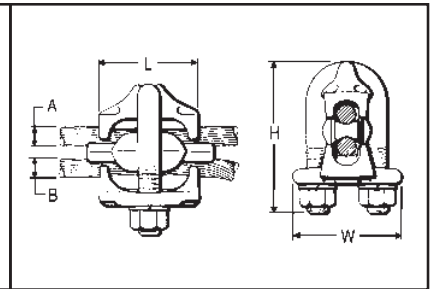

RUS Accepted

Catalog Number	Run A		Tap B		Dimensions		
	ACSR, 6201, 5005	Aluminum	ACSR, 6201, 5005	Aluminum	L	H	W
UW2R	6 - 2	6 Str. - 2 Str.	6 - 2	6 Str. - 2 Str.	1-1/2"	2-5/8"	1-7/8"
UW25R	6 - 1/0	6 Str. - 2/0 Str.	6 - 1/0	6 Str. - 2/0 Str.	1-7/8"	2-7/8"	2"

† Accommodates compressed conductors within diameter range.

Blue highlighted items are industry standard and most frequently ordered.

## TYPE UC

### PARALLEL CLAMP

For Range of Copper

Type UC connector accommodates large range of conductors in either groove, reducing inventory to a minimum. Interlocking finger design provides firm grip with maximum contact length. High strength, corrosion resistant silicone bronze hardware. One wrench installation.

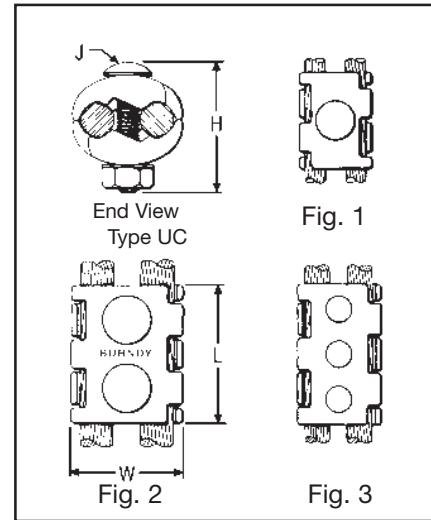

H-12

Catalog Number	Conductor (Either Groove)	Fig. No.	Dimensions			
			L	H	J	W
UC6W25	6 Sol. - 1/0 Str.	1	1-3/4"	1-5/8"	3/8"	1-3/8"
UC4W28	4 Sol. - 4/0 Str.	2	2-1/8"	2"	3/8"	1-3/4"
UC2W30	2 Sol. - 300	2	2-3/8"	2-1/8"	3/8"	2"
UC2834	4/0 Str. - 500	3	4-1/4"	2-7/8"	1/2"	2-1/2"
UC3040	300 - 800	3	4-1/4"	3-3/8"	1/2"	3"
UC3444	500 - 1000	3	4-1/4"	3-5/8"	1/2"	3-1/2"

## TYPE CP

### PARALLEL CLAMP

For Copper

High strength, high copper alloy Type CP is recommended for heavy duty parallel connections. Silicone bronze DURIMUM™ hardware and cast copper body provides corrosion resistant assembly. Long contact surface provides excellent contact and assures full conductivity.

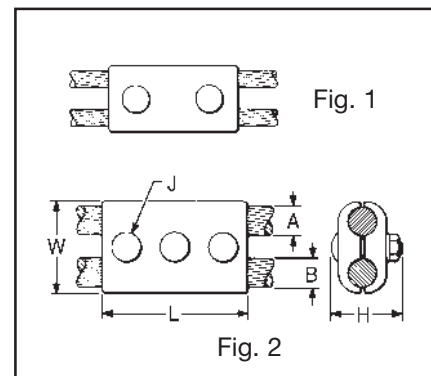

Catalog Number	Groove		Fig. No.	Dimensions		
	A	B		L	J	W
CP2C2C	2 Str.	2 Str.	1	2-1/2"	3/8"	1-1/4"
CP2525	1/0 Str.	1/0 Str.	1	3"	3/8"	1-5/8"
CP2626	2/0 Str.	2/0 Str.	1	3"	3/8"	1-5/8"
CP2828	4/0 Str.	4/0 Str.	2	4"	3/8"	2"
CP2929	250	250	2	4"	3/8"	2"
CP3434	500	500	2	5"	1/2"	2-1/2"

For other sizes contact factory.

Blue highlighted items are industry standard and most frequently ordered.

**TYPE QPX**

**VERSITAP™ PARALLEL CLAMP**

For Copper, Copperweld and Copperweld-Copper

The VERSITAP™ Type QPX is recommended for Tee, Cross, Parallel, Butt and Tap connections. Range-taking, only 10 connectors required to accommodate conductor sizes from #6 Str. to 1000 kcmil. Edges are rounded for easy taping. Made of high strength, high conductivity copper alloy and silicone bronze DURIMUM™ hardware.

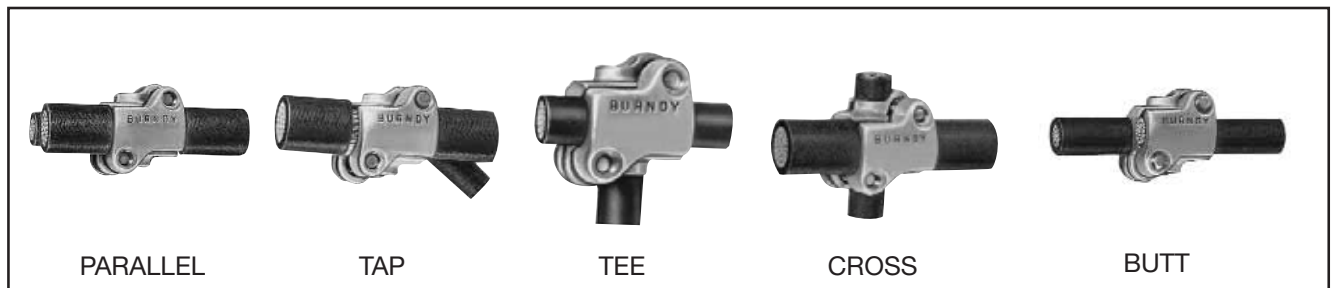
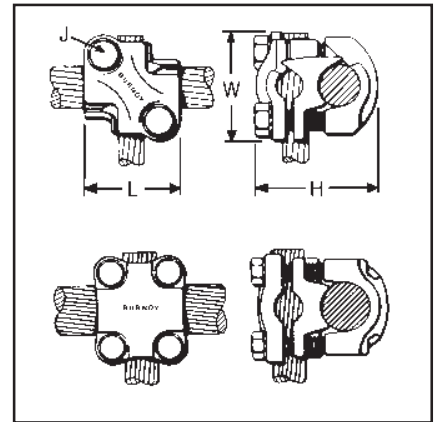

H-13

Catalog Number	Run			Tap			Dimensions					
	Copper	Copperweld	Copperweld -Copper	Copper	Copperweld	Copperweld -Copper	L	H	J	W		
<b>QPX2C2C</b>	6 Str. - 2 Str.	5 Sol. - 3 #7	8A - 4A	6 Str. - 2 Str.	5 Sol. - 3 #7	8A - 4A	1-3/8	1-5/8	5/16	1-3/8		
<b>QPX282C</b>	1 Str. - 4/0 Str.	7 #9 - 7 #5	3A - 3/0V					2		1-5/8		
<b>QPX2828</b>				1 Str. - 4/0 Str.	7 #9 - 7 #5	3A - 3/0V	1-7/8	2-1/8	3/8	1-7/8		
<b>QPX342C</b>	250 - 500	19 #19 - 19 #6	4/0 EK	6 Str. - 2 Str.	5 Sol. - 3 #7	8A - 4A	1-3/8	2-1/2	3/8	2		
<b>QPX3428</b>				1 Str. - 4/0 Str.	7 #9 - 7 #5	3A - 3/0V	1-3/4					
<b>QPX3434</b>				250 - 500	19 #9 - 19 #6	4/0 EK	2				2-3/4	2-1/8
<b>QPX442C</b>	500 - 1000	19 #6	—	6 Str. - 2 Str.	5 Sol. - 3 #7	8A - 4A	1-3/8	3/8	5/16	2-1/4		
<b>QPX4428</b>				1 Str. - 4/0 Str.	7 #9 - 7 #5	3A - 3/0V	1-7/8				2-7/8	
<b>QPX4434</b>				250 - 500	19 #19 - 19 #6	4/0 EK	2				3	2-3/8
<b>QPX4444</b>				500 - 1000	19 #6	—	2-5/8				3-3/8	2-5/8

Blue highlighted items are industry standard and most frequently ordered.

**TYPE VT**

**T-CONNECTOR**

For Copper Cable to Cable

High copper alloy T-connector for cable run, cable tap. DURIMUM™ V-bolt clamping elements accommodate large range of cable and are particularly suited for extra flexible cable. (One-wrench installation).

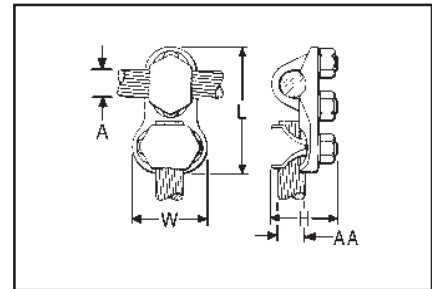

H-14

Catalog Number	Conductor		H	L	W
	Run (A)	Tap (AA)			
<b>VT2C2C</b>	8 Sol. - 2 Str.	8 Sol. - 2 Str.	1-3/8"	2-3/8"	1"
<b>VT2525</b>	6 Sol. - 1/0 Str.	6 Sol. - 1/0 Str.	1-5/8"	2-5/8"	1-1/4"
<b>VT2825</b>	1/0 Str. - 4/0 Str.			3-1/8"	
<b>VT2828</b>			1/0 Str. - 4/0 Str.		1-3/4"
<b>VT3025</b>	1/0 Str. - 300	6 Sol. - 1/0 Str.	1-7/8"	3-3/8"	1-1/8"
<b>VT3030</b>		1/0 Str. - 300			2"
<b>VT3425</b>	300 - 500	6 Sol. - 1/0 Str.	2-3/8"	3-1/4"	1-1/4"
<b>VT3428</b>		1/0 Str. - 4/0 Str.		3-1/2"	1-3/4"
<b>VT3430</b>		1/0 Str. - 300		3-5/8"	2"
<b>VT3434</b>		300 - 500		3-3/4"	2-1/4"
<b>VT4040</b>	500 - 800	500 - 800	2-5/8"	4-3/4"	2-5/8"
<b>VT4425</b>	750 - 1000	6 Sol. - 1/0 Str.	2-7/8"	4-3/8"	1-1/4"
<b>VT4428</b>		1/0 Str. - 4/0 Str.		4-1/8"	1-3/4"
<b>VT4834</b>	1500 - 2000	300 - 500	4-1/4"	5-1/4"	2-1/4"

Blue highlighted items are industry standard and most frequently ordered.

## TYPES UCG-R & UCG-RS

### TAPIT™ PARALLEL CLAMP

For All Combinations of Copper, Aluminum†, ACSR†, 6201 & 5005

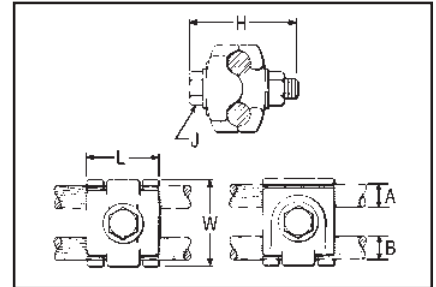
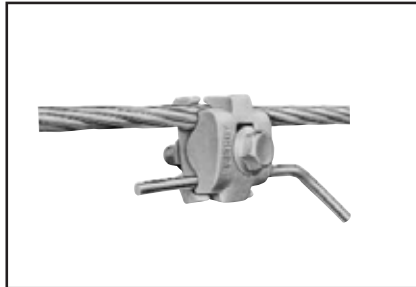

Multiple purpose parallel groove clamp made of high strength, high conductivity, non-copper bearing aluminum alloy. Properly proportioned to minimize stress corrosion and deterioration by galvanic action.

hex head, round collar, high strength galvanized steel bolt allows one or two-wrench installation.

Interlocking fingers on connector body halves prevent mismatching. Square shank,

Also supplied pre-filled with PENETROX™ joint compound and Stripsealed. RUS Accepted

Catalog Number		Groove A		Groove B		Dimensions			
With Stripseal	Without Stripseal	Copper & Aluminum†	ACSR†, 6201, & 5005	Copper & Aluminum†	ACSR†, 6201, 5005	L	H	J	W
UCG25R2RS**	UCG25R2R**	6 Sol. - 1/0 Str.	8 - 1/0	6 Sol. - 2 Str.	8 - 2	1-1/8"	1-7/8"	5/16"	1-3/8"
UCG25RS	UCG25R	8 Str. - 1/0 Str.	6 - 1/0	8 Str. - 1/0 Str.*	6 - 1/0	1-3/8"	2-1/8"	3/8"	1-5/8"
UCG28RS	UCG28R	1/0 Str. - 4/0 Str.	1/0 - 4/0	1/0 Str. - 4/0 Str.	6 - 4/0	1.38"	2.21"	3/8-16"	1.87"
UCG32RS	UCG32R	1/0 Str. - 397.5	1/0 - 336.4	8 Str. - 2/0 Str.	6 - 1/0	1-1/2"	2-5/8"	3/8"	2-1/8"

\* Maximum recommended combinations: 1/0 Aluminum or ACSR Run - #2 Str. Copper Tap; 1/0 Copper Run - 1/0 Aluminum or ACSR Tap.

† Accommodates compact and compressed conductors within diameter range.

\*\* Supplied with galvanized steel, square shank bolt.

H-15

## TYPES UC-R & UC-RS

### TAPIT™ PARALLEL CLAMP

For All Combinations of Copper, Aluminum†, ACSR†, 6201 & 5005

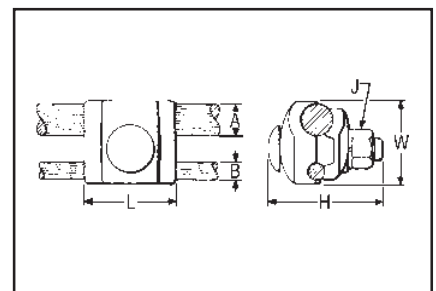

High strength, high conductivity, non-copper bearing aluminum alloy, properly proportioned to minimize stress corrosion and deterioration by galvanic action.

strength galvanized steel bolt allows one wrench installation.

Keying tabs on connector body halves prevent mismatching. Square shank, high

Also supplied pre-filled with PENETROX™ joint compound and Stripsealed. RUS Accepted

Catalog Number		Groove A		Groove B		Dimensions			
With Stripseal	Without Stripseal	Copper & Aluminum†	ACSR†, 6201, & 5005	Copper & Aluminum†	ACSR†, 6201, 5005	L	H	J	W
UC25R2RS	UC25R2R	8 Sol. - 1/0 Str.	6 - 1/0	8 Sol. - 2 Str.	6 - 2	1-1/8"	1-5/8"	5/16"	1-3/8"
UC28RS	UC28R	1/0 Str. - 4/0 Str.	1/0 - 4/0	8 Sol. - 1/0 Str.*	6 - 1/0	1-3/8"	2-3/8"	3/8"	1-7/8"
UC32RS	UC32R	1/0 Str. - 397.5	1/0 - 336.4 (26-7)	6 Sol. - 2/0 Str.	6 - 1/0	1-1/2"	2-3/8"	3/8"	2-1/4"
—	UC33R	4/0 Str. - 400	3/0 - 336.4 (30-7)	6 Sol. - 2/0 Str.	6 - 2/0	1-3/4"	2-3/4"	1/2"	2-1/4"

\* Maximum recommended combinations: 4/0 aluminum or ACSR RUN - #2 Str. copper TAP.

† Accommodates compact and compressed conductors within diameter range.

Blue highlighted items are industry standard and most frequently ordered.

### TYPE UC KIT

UC connector accommodates a large range of copper conductors in either groove. Kits include connector and cover

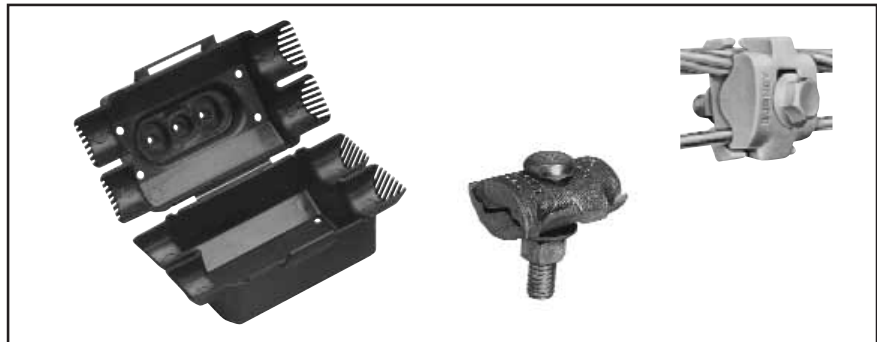

Catalog Number	Conductor (Either Groove)	Fig. No.	Dimensions			
			L	H	J	W
UC6W25CONKIT	6 Sol - 1/0 Str.	1	1-3/4"	1 5/8"	3/8"	1-3/8"
UC4W28CONKIT	4 Sol - 4/0 Str.	2	2-1/8"	2"	3/8"	1-3/4"

Note: For connectors with break-away bolt contact factory.

H-16

### UCCOVER1BOX25

#### TAPIT™ COVER

For Selected UC and UCG Tap Connectors

High density Polyethylene cover accommodates several sizes of UC and UCG connectors. One piece design. Simply slip over the connector and snap shut. Supplied in black.

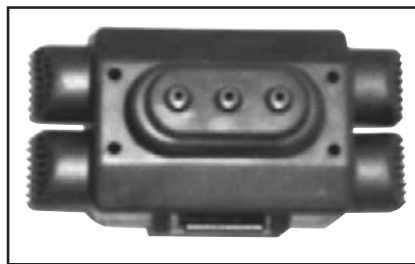

UCCOVER1 for use with:

- UCG25R2RS      UCG25R2R
- UCG25RS        UCG25R
- UCG28RS        UCG28R
- UC25R2RS      UC25R2R
- UC28RS         UC28R
- UC6W25         UC4W25

Blue highlighted items are industry standard and most frequently ordered.



**TYPE LSC**

**CATCHER**

For Aluminum and ACSR  
Primary Covered Conductor  
(Tree Wire)

Cast aluminum lightning shield clamp with a galvanized steel eye bolt for use on covered aluminum and ACSR primary overhead distribution conductors (“Tree Wire”).

They are designed to protect the “Tree Wire” from burn-down causing service interruption during high lightning activity. For further application details contact the factory.

Conductor groove is pre-filled with PENETROX™ A13, which is compatible with cable insulation and individually bagged.

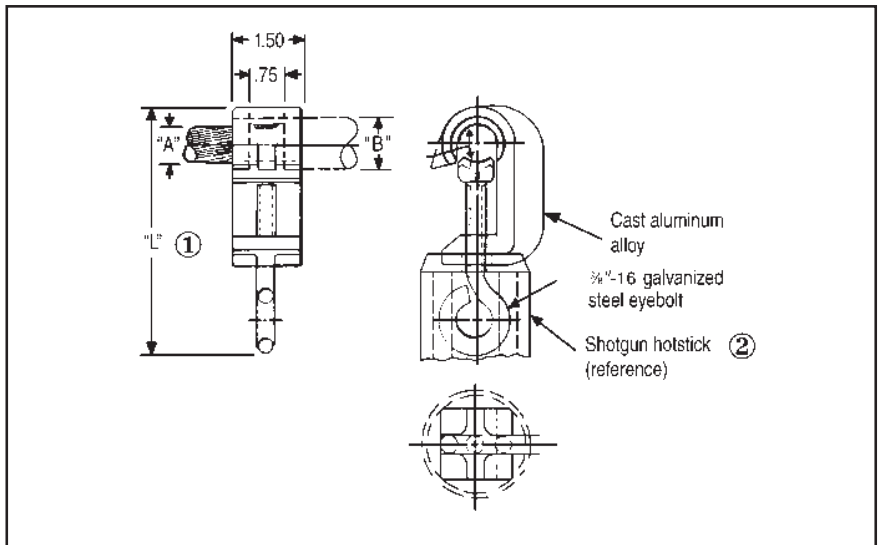

H-17

Catalog Number	Cable	Accommodates Cable Dia. "A"	Insul. Dia. "B" (Max.)	"L"
LSC1/0	1/0 Str. AAC - 1/0 ACSR	.368 - .398	.65"	4.5"
LSC1/0-1	1/0 Str. AAC - 1/0 ACSR	.368 - .398	.83"	4.5"
LSC556	4/0 Str. - 556.5 AAC	.528 - .858	1.16"	5.9"
LSC556-1	4/0 Str. - 556.5 AAC	.528 - .858	1.34"	5.9"

- ① Approx. assembly length over eyebolt with cable clamped. Also approx. eyebolt position when shipped.
- ② Assembly can be installed using a shotgun hotstick as shown. Assembly instructions are supplied with each connector.

Blue highlighted items are industry standard and most frequently ordered.

## COMPRESSION TAP CONNECTORS

BURNDY® compression tap connectors are wide range-taking; accommodate copper, aluminum, and ACSR; are easy to install; and are dependable and economical. They are designed to be installed with BURNDY® “matched” hand, hydraulic, and power-driven hydraulic tooling. The connector line consists of C-shaped, Figure 3, Figure 6-shaped and HYCRIMP™ tap connectors, disconnectable T-taps, terminals and stirrups.

The copper CRIMPIT™ is a range-taking, reversible, C-shaped compression tap connector for combinations of copper conductors. Twelve connectors take tap combinations from #10 AWG through 4/0, and all sizes are installed with dies that also install aluminum connectors. Sizes accommodating conductors up to No. 2 may be installed with the MD6 and OUR840; all sizes may be installed with the Y35 or Y750. They make “hot” installation easy by permitting the lineman to grip the CRIMPIT™ in the compression tool and then place it on the line. The tap is then inserted and the CRIMPIT™ is compressed. Massive C-shape forces tap and line conductors together to form dependable, low-cost, low-resistance connections.

The CABELOK CRIMPIT™ is a range-taking, universal and reversible, Figure 3-shaped aluminum compression tap connector with an adjustable spacer which separates the

conductors. It accommodates combinations of copper, aluminum, and ACSR conductors from No. 6 up to 4/0, and is installed with the common O and D3 dies. The broad range capacity of each CABELOK CRIMPIT™ reduces the number of connectors required and simplifies connector selection.

The spacer holds the run or tap in place permitting the lineman either to approach the line with the connector held in the tool and with the tap in the connector, or to assemble the connector and tap on the line and then bring up the tool to crimp.

Each CABELOK CRIMPIT™ is pre-filled with PENETROX™ joint compound and individually bagged. These packages are clearly marked with the entire conductor range of the connector as well as pertinent tooling information. The open side of the CABELOK CRIMPIT™ makes “hot” installations easy by allowing the connector to be carried to the energized line in the crimping tool (MD6, Y35 or Y750 hot-line types).

The Figure 6-shaped aluminum compression tap connector is one of the widest range-taking compression tap connectors available. It accommodates copper, aluminum, or ACSR conductors in very broad ranges. Only four connectors are required to accommodate a range from No. 6 to 600 kcmil. This broad range is made possible by the long ram stroke of the Y35 and Y750.

HYCRIMP™ compression tap connectors accommodate ACSR, stranded copper or aluminum, solid copper or aluminum, and compact conductors. Seventeen sizes are available to accommodate all conductors from #6 solid to 954 MCM compact. All HYCRIMP™ connectors can be installed with industry standard O, D, N and R dies. Each connector is factory filled with BURNDY® PENETROX™ and individually boxed for ease of handling, identification, and installation.

BURNDY’s disconnectable T-taps and jumper loop splices offer an economical approach to sectionalizing or isolating equipment on energized lines. They combine the best features of compression and mechanical connectors. The pads can be easily assembled or separated from each other with hot-line tools.

The STIRRUP™ combines a compression C-shaped Figure 6-shaped or H-shaped element for the run conductor, and a factory installed bail which accommodates a hot-line clamp. The line element can be gripped in the tool and carried to the line and then crimped.

**Note:** Aluminum bodied compression tap connectors are not recommended for making copper to copper connections. Two connectors are recommended when feeding a line in both directions.

Blue highlighted items are industry standard and most frequently ordered.

**YC-C**

**COPPER CRIMPIT™**

Line Tap for Range of Copper

Range-taking compression tap connector made of pure copper. Designed to be gripped in the jaws or dies of installation tool, then slipped directly over line for easy installation. Also used for deadending.

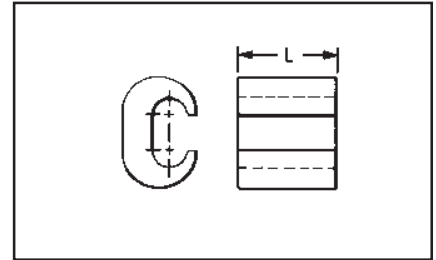
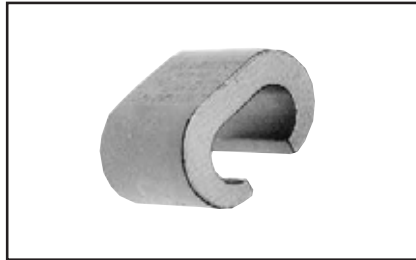

Copperweld-Copper Conductors
8A - Use CRIMPITS™ accommodating 6 str. Copper
6A - Use CRIMPITS™ accommodating 4 Str. Copper
4A - Use CRIMPITS™ accommodating 2 Str. Copper
2A - Use CRIMPITS™ accommodating 1/0 & 2/0 Copper



RUS Accepted

Catalog Number	Run	Tap	L	Die Index	Tools, Die Set Catalog Number, & (Number of Crimps)			CRIMPIT™ for 1 Str. Copper	
					MD7, MD6	OUR840	Y35, Y750, Y45†, Y46‡	Run	Tap
YC10C10*	12 Sol. - 10 Str.	12 Sol. - 10 Str.	3/8	238	W238 (1)	W238 (1)	U238 (1)		
YC8C8	8 Sol. - 8 Str.	10 Sol. - 8 Str.	1/2	162 or K	W 162 (2)	W162 (2)	U162** (1)		
YC4C8	6 Sol. - 4 Str.	8 Sol. - 8 Str.	5/8	BG or 5/8	BG (2) W-BG** (1)	XBG (2)	U-BG (1)	-	-
YC4C6		6 Sol. - 6 Str.							
YC4C4		4 Sol. - 4 Str.							
YC2C4	2 Sol. - 2 Str.	8 Sol. - 4 Str.	3/4	C	W-C (2)	-	U-C (1)	1 Str.	6.8 Str., 8 Sol.
YC2C2	2 Sol. - 2 Str.	2 Sol. - 2 Str.							
YC26C2	1/0 Sol. - 2/0 Str.	8 Sol. - 2 Str.	7/8	E or O	-	-	U-E (3) U-O (1)	1 Str.	1 or 2 Str.
YC26C26		1/0 Sol. - 2/0 Str.							
YC28C2	3/0 Sol. - 4/0 Str.	6 Sol. - 2 Str.	1-1/16	F or D3	-	-	U-F (3) U-D3 ** (1)	-	-
YC28C26		1/0 Sol. - 2/0 Str.							
YC28C28		3/0 Sol. - 4/0 Str.							

\*\* Multiple crimp die set. Makes more than one crimp per tool compression. Figure ( ) indicates number of compressions.  
 † U Die with adapter PT-6515.  
 ‡ U Die with adapter PUADP-1.  
 \* Not UL Listed.

H-19

**TYPE YP-C**

**COPPER CRIMPIT™**

Line Tap for Extra Wide Range of Copper

Figure “6” -shaped, wide range-taking copper, compression tap connector for primary service taps and secondary service drops. Connector can be gripped in tool and slipped over the line for easy installation.

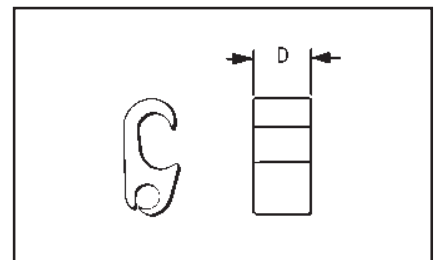

Catalog Number	D	Run	Tap	Die Index	Tools, Die Set Catalog No., & (Number of Crimps) Y35, Y750, Y45†, Y46‡
YP2C2	.75	6 Sol. - 2 Str.	6 Sol. - 2 Str.	0	U-O (1)
YP28C28	1.00	2/0 Str. - 4/0 Str.	2/0 Str. - 4/0 Str.	D	U-D3 (1)
YP29C26	.75	1/0 Str. - 250	4 Sol. - 2/0 Str.		

† U Die with adapter PT-6515.  
 ‡ U Die with adapter PUADP-1.

Blue highlighted items are industry standard and most frequently ordered.

## TYPE YC-A

### ALUMINUM CRIMPIT™

Line Tap for Combinations of Aluminum, ACSR, 6201, 5005, Compressed and Compact Conductors

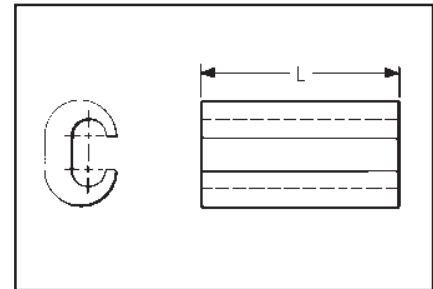

Range-taking, C-shaped aluminum compression tap, or dead-ending connector designed to eliminate effects of cold flow. Can be gripped in tool and slipped over line for easy crimping. Pre-filled with PENETROX™ joint compound and Stripsealed.

H-20

Catalog Number	Run		Tap		L	Die Index	Tools, Die Set Catalog No., & (Number of Crimps)		
	Aluminum	ACSR, 6201, 5005	Aluminum	ACSR, 6201, 5005			MD7, MD6	Y35, Y750, Y45†, Y46‡	
YC4A6	6 Sol. - 4 Str.	6	6 Sol. & Str.	—	1-1/4"	BG or 5/8	BG (4)	U-BG (2)*	
YC4A4			4 Sol. & Str.	6			W-BG (2)*		
YC2A4	2 Sol. & Str.	4 - 2	4 Sol. & Str.	6	1-1/2"	C	W-C (4)	U-C (2)*	
YC2A2			2 Sol. & Str.	4 - 2					
YC25A4	1/0 Str.	1/0	6 Str. - 4 Str.	6 - 4	1-1/2"	C	W-C (4)	U-C (2)*	
YC25A2			2 Sol. & Str.	2	2-1/4"	C	W-C (6)	U-C (3)*	
YC25A25	1/0 Str. - 2/0 Str.	1/0 - 2/0	1/0 Str. - 2/0 Str.	1/0	1-3/4"	Q	W-Q (6)*		
YC26A25	1/0 Str. - 2/0 Str.		1/0 Str.	1/0	2-1/2"	D**	—	U-D (3)	
YC26A26		2/0 Str.	2/0						
YC28A2	3/0 Str. - 4/0 Str.	3/0 - 4/0	6 Sol. - 2 Str.	6 - 2	2-3/4"	H	—	U-H (3)	
YC28A25			1/0 Str.	1/0					
YC28A26			2/0 Str.	2/0					
YC28A28			3/0 Str. - 4/0 Str.	3/0 - 4/0					
YC33R26	300 - 397.5	336.4 (18-1) (26-7)	2 Str. - 2/0 Str.	2 - 1/0	1-1/2"	R	—	U-R (2)	

\* Multiple crimp die set; makes more than one crimp per tool compression. Figure indicates number of compressions.

\*\* Index number "D" is not "D3" Cabelok CRIMPIT™ die.

† U Die with adapter PT-6515.

‡ U Die with adapter PUADP-1.

Blue highlighted items are industry standard and most frequently ordered.

**TYPES YP-U, YPC-U**

**CABELOK CRIMPIT™**

Line Tap for Copper, Aluminum or ACSR

Wide range, universal and reversible, Figure “3” -shaped aluminum connector with adjustable overhanging spacer that separates conductors. Spacer holds run or tap in place permitting lineman to either approach the line ready to crimp, or to assemble connector and tap on run and then crimp. Massive aluminum design minimizes conductor corrosion due to galvanic action. Pre-filled with PENETROX™ joint compound and Stripsealed. Conductor range and tooling information clearly printed on connector and package.

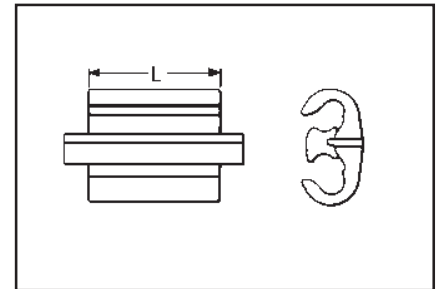
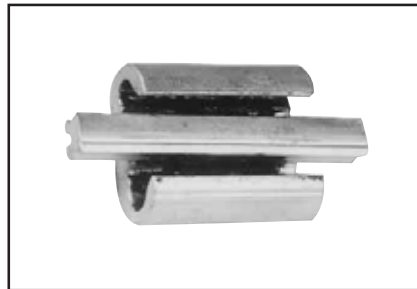

RUS Accepted

H-21

Catalog Number	Conductor (See Chart Below for Compressed Conductor)						L	Die Index	Tool, Die Set Catalog No., & (Number of Crimps)	
	Groove A			Groove B					MD7, MD6	Y35, Y750, Y45†, Y46‡
	Solid	Stranded	ACSR	Solid	Stranded	ACSR				
YP2U3*	6, 4, 3, 2	6, 4, 3,	6, 4	6, 4, 3, 2,	6, 4, 3	6, 4	1-1/2"	0	W-0 (4)	U-0(1)
YP26AU2	1, 1/0, 2/0, 3/0	2, 1, 1/0, 2/0	3, 2, 1, 1/0	6, 4, 3, 2, 1, 1/0	6, 4, 3, 2, 1	6, 4, 3, 2	1-5/8"	D3	MD6 (4)	U-D3 (1)
YP25U25**	2/0, 3/0	1, 1/0, 2/0	1, 1/0	2/0, 3/0	1, 1/0, 2/0	1, 1/0				
YP27AU4	2/0, 3/0, 4/0	1/0, 2/0, 3/0	1/0, 2/0	6, 4, 3, 2,	6, 4, 3	6, 4				
YP27AU2				2, 1, 1/0	3, 2, 1	4, 3, 2				
YP27AU26	3/0, 4/0	2/0, 3/0	2/0	2/0, 3/0	1/0, 2/0	1, 1/0, 2/0				
YP28U2	—	4/0	3/0, 4/0	2, 1, 1/0	4, 3, 2, 1	4, 3, 2				
YP28U26				2/0, 3/0	1/0, 2/0	1, 1/0, 2/0	3-1/2"			
YPC28U28	4/0	3/0, 4/0		4/0	2/0, 3/0, 4/0	2/0, 3/0, 4/0	2-3/4"	MD6 (9)	U-D3 (2)	

Catalog Number	Compressed Conductor				L	Die Index	Tool, Die Set Catalog No., & (Number of Crimps)	
	Groove A		Groove B				MD7, MD6	Y36, Y750, Y45†, Y46‡
	Stranded Aluminum	ACSR	Stranded Aluminum	ACSR				
YP2U3*	6, 4, 3, 2	6, 4, 3	6, 4, 3, 2	6, 4, 3	1-1/2"	0	W-0 (4)	U-0 (1)
YP26AU2	2, 1, 1/0, 2/0	2, 1, 1/0, 2/0	6, 4, 3, 2, 1	6, 4, 3, 2, 1	1-5/8"	D3	MD (4)	U-D3 (1)
YP25U25**	1/0, 2/0	1/0, 2/0	1/0, 2/0	1/0, 2/0				
YP27AU4	2/0, 3/0	1/0, 2/0, 3/0	6, 4, 3	6, 4, 3				
YP27AU2			3, 2, 1	4, 3, 2, 1				
YP27AU26	3/0	2/0, 3/0	1/0, 2/0, 3/0	1/0, 2/0				
YP28U2	4/0, 250, 266.8	4/0, 266.8, (18/1)	3, 2, 1	4, 3, 2, 1				
YP28U26			1/0, 2/0, 3/0	1/0, 2/0				
YPC28U28			3/0, 4/0	3/0, 4/0	3-1/2"	MD6 (9)	U-D3 (1)	
	4/0	3/0, 4/0			2-3/4"		—	U-D3 (2)

\* TAKES UP to #2 ACSR maximum in either groove if other wire is #2 solid or smaller.

\*\* TAKES DOWN to #2 ACSR minimum in either groove if other groove wire is 1/0 stranded or larger.

† U Die with adapter PT-6515.

‡ U Die with adapter PUADP-1.

Blue highlighted items are industry standard and most frequently ordered.

## TYPE YPC-U

### UNIVERSAL CRIMPIT™

Line Tap for Combinations of Copper, Aluminum, ACSR, 6201, 5005 and Compressed and Compact Conductors

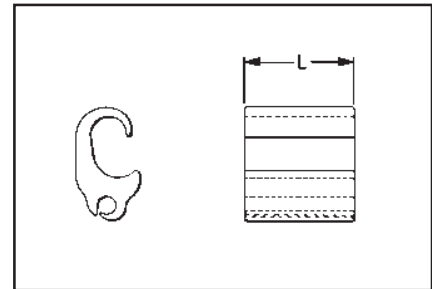

Extra wide range universal connector. Two dies and 5 connectors take run sizes 1/0-600, and tap sizes 6-400. Wide range made possible by long ram travel of BURNDY® HYPRESS™ tools. Figure “6”- shape separates run and tap wires, and minimizes galvanic corrosion of conductors. Connector

can be gripped in tool and slipped over line for easy installation. Pre-filled with PENETROX™ joint compound and Stripsealed.

H-22

Catalog Number	Run		Tap		L	Die Index	Tools, Die Set Catalog No., & (Number of Crimps)		
	Aluminum & Copper	ACSR, 5005	Aluminum & Copper	ACSR, 5005			Y35, Y750	Y45†	Y46‡
<b>YPC28U4</b>	3/0 - 4/0 Str. & 4/0, 250, 266.8 Alum. Compressed	3/0 - 4/0 & 4/0, 266.8 (18/1) ACSR Compressed	6, 4, 3 Str. 6, 4, 3, 2 Sol. & 6, 4, 3, Alum. Compressed	6, 4 & 6, 4, 3 ACSR Compressed	1-5/8	D3 ②	U-D3 (1)	U-D3 (1)	U-D3 (1)
<b>YPC28U26</b>	1/0 (7) - 4/0 (7)	1/0 - 4/0	3 Sol. - 2/0 (7)	4 - 1/0	2-3/4	D3	U-D3 (2)	—	—
<b>YPC28U28</b> ①	3/0, 4/0 Str. 4/0 Sol. & 4/0, 250, 266.8 Alum. Compressed	3/0 - 4/0 & 3/0 - 4/0 266.8 (18/1) ACSR Compressed	2/0, 3/0, 4/0 Str. 4/0 Sol. & 3/0, 4/0, 250 266.8 Alum. Compressed	2/0, 3/0, 4/0 & 3/0, 4/0, 266.8 (18/1) ACSR Compressed	2-3/4	D3	U-D3 (2)	U-D3 (2)	U-D3 (2)
<b>YPC28R28A</b>	3/0, 4/0 Str. & 4/0, 250, 266.8 Alum. Compressed	3/0 - 4/0 & 4/0, 266.8 (18/1) ACSR Compressed	3/0 - 4/0 Str. & 4/0 Alum. Compressed	3/0 & 4/0 ACSR Compressed	2-3/4	D3	U-D3 (2)	U-D3 (2)	U-D3 (2)
<b>YPC33R26U</b>	250 (37) - 400 (37)	266.8 (18-1) - 397.5 (18-1)	6 Sol. - 2/0 (19)	6 - 1/0	2-1/8	N	U-N (2)	S-N (2)	P-N (2)
<b>YPC33R28R</b>	250 (37) - 477 (37)	266.8 (18-1) - 397.5 (18-1)	2/0 (19) - 4/0 (19)	2/0 - 4/0	8-7/8	N	U-N (3)	S-N (3)	P-N (3)
<b>YPC33R33R</b>	250 (37) - 400 (37)	266.8 (18-1) - 397.5 (18-1)	250 (37) - 400 (37)	266.8 (18-1) - 397.5 (18-1)	8-7/8	N	U-N (3)	S-N (3)	P-N (3)
<b>YPC38R26U</b>	477 (19) - 600 (61)	397.5 (26-7) - 556.5 (18-1)	6 Sol. - 2/0 (19)	6 - 1/0	2-1/8	N	U-N (2)	S-N (2)	P-N (2)
<b>YPC36A32</b>	397.5 (19) - 600 (61)	336.5 (26-7) - 556.5 (18-1)	2/0 (7) - 400 (37)	2/0 (6-1) - 397.5 (18-1)	5	Z	—	S-Z (3)	—
<b>YPC36A36</b>	397.5 (19) - 600 (61)	336.5 (26-7) - 556.5 (18-1)	397.5 (19) - 600 (61)	397.5 (26-7) - 556.5 (18-1)	6-3/4	Z	—	S-Z (4)	—
<b>YPC40A32</b>	600 (61) - 800 (61)	556.5 (18-1) - 795 (26-7)	2/0 (7) - 400 (37)	2/0 (6-1) - 397.5 (18-1)	5	T	—	S-T (3)	—
<b>YPC40A36</b>	600 (61) - 800 (61)	556.5 (18-1) - 795 (26-7)	397.5 (19) - 600 (61)	336.4 (26-7) - 556.5 (18-1)	5	T	—	S-T (3)	—
<b>YPC40A40</b>	600 (61) - 954 (61)	556.5 (18-1) - 795 (26-7)	600 (61) - 954 (61)	556.5 (18-1) - 795 (26-7)	9-7/8	T	—	S-T (6)	—

① 2/0 Str. Cu Aluminum and 2/0 ACSR may also be installed in run when tap is 3/0 Str. or larger.

② YPC28U4 only may be installed with MD6 HYTOOL™ and the BCT500HS with D<sup>3</sup> groove.

† U Die with adapter PT-6515.

‡ U Die with adapter PUADP-1.

Blue highlighted items are industry standard and most frequently ordered.

**TYPE YC-U**

**UNIVERSAL CRIMPIT™**

Line Tap Combinations of Copper, Aluminum, ACSR, 6201, 5005 and Compressed and Compact Conductors

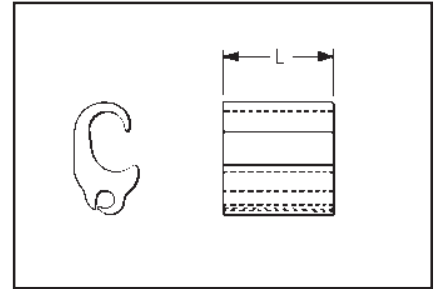

Figure “6” -shaped, wide range-taking aluminum compression tap connector for smaller primary service taps and secondary service drops. Minimizes galvanic corrosion of conductors. Connector can be gripped in

tool and slipped over line for easy installation. Installed with aluminum CRIMPIT™ dies. Pre-filled with PENETROX™ joint compound and Stripsealed.

Catalog Number	Run		Tap		L	Die Index	Tools, Die Set Catalog No., & (Number of Crimps) Y35, Y750, Y45†, Y46‡
	Aluminum & Copper	ACSR, 6201, & 5005	ACSR, 6201, & 5005	Aluminum & Copper			
YC4U1	4 Sol. - 4 Str.	4	6 - 1 Str.	6 Sol. - 2 Str.	1-7/8	D*	U-D (2)
YC1U1	2 Str. - 1 Str.	2					
YC28U26	1/0 Str. - 4/0 Str.	1/0 - 4/0	6 - 1/0	6 Sol. - 2/0 Str.	2-1/8	H	U-H (2)
YC33R26U	300 - 400	266.8 (6-7) - 336.4 (30-7)				R	U-R (2)

\* Die Index “D” is not Die Index “D3” (Cabelok & Universal CRIMPIT™ Die).  
 † U Die with adapter PT-6515.  
 ‡ U Die with adapter PUADP-1.

H-23

**TYPES YPC-A-U, YPC-R-U**

**CRIMPIT™**

Street Lighting Tap for Combinations of Copper, Aluminum, ACSR, Compressed and Compact Conductors

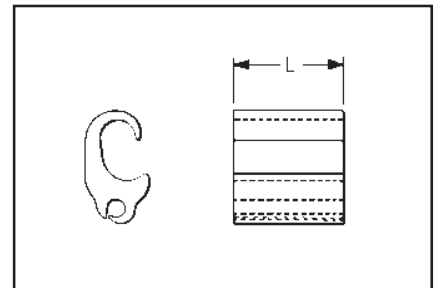

Compact compression connector designed to tap small lighting wires from secondaries. Figure “6” -shape separates run and tap, and minimizes galvanic corrosion. Connector can

be gripped in tool and slipped over line for easier installation. Pre-filled with PENETROX™ joint compound and Stripsealed.

Catalog Number	Run			Tap		L	Die Index	Tools, Die Set Catalog No., & (Number of Crimps)		OUR840
	ACSR	Compressed ACSR	Aluminum & Copper	Compressed Aluminum	Aluminum & Copper			MD7, MD6	Y35, Y750, Y45†, Y46‡	
YPC2A8U	6 - 4	6 - 2	4 - 2 Sol. 6 - 2 Str.	4 - 2	14 Sol. - 8 Str.	5/8	BG or 5/8	BG (2) W-BG (1)*	U-BG (1)*	XBG
YPC26R8U	2 - 3/0	1 - 3/0	1 - 3/0 Str.	1/0 - 3/0		3/4	0	W-0 (2)	U-0 (1)	W-0

\* Multiple crimp die set, makes more than one crimp per tool compression. Figure indicates number of compressions.  
 † U Die with adapter PT-6515.  
 ‡ U Die with adapter PUADP-1.

Blue highlighted items are industry standard and most frequently ordered.

**TYPE CC**

**CRIMPIT™ COVER**

For All O, D and N Die Tap Connectors

High density polyethylene cover accommodates most industry connectors in the O, D and N range. Four sizes cover the full #6-600 kcmil conductor range. One piece design. No extra hardware needed. Simply slip over connector and snap shut. Supplied in Black.



Catalog Number	Maximum Connector Length	Connector Series Accommodate
<b>CCO</b>	2-1/2	O Die
<b>CCD</b>	2-3/4	D Die
<b>CCN</b>	2-1/8	Short N Die
<b>CCNL</b>	5-3/16	Long N Die and YP28U26

H-24

Blue highlighted items are industry standard and most frequently ordered.



**SEVEN CONNECTOR  
SELECTOR CHART**

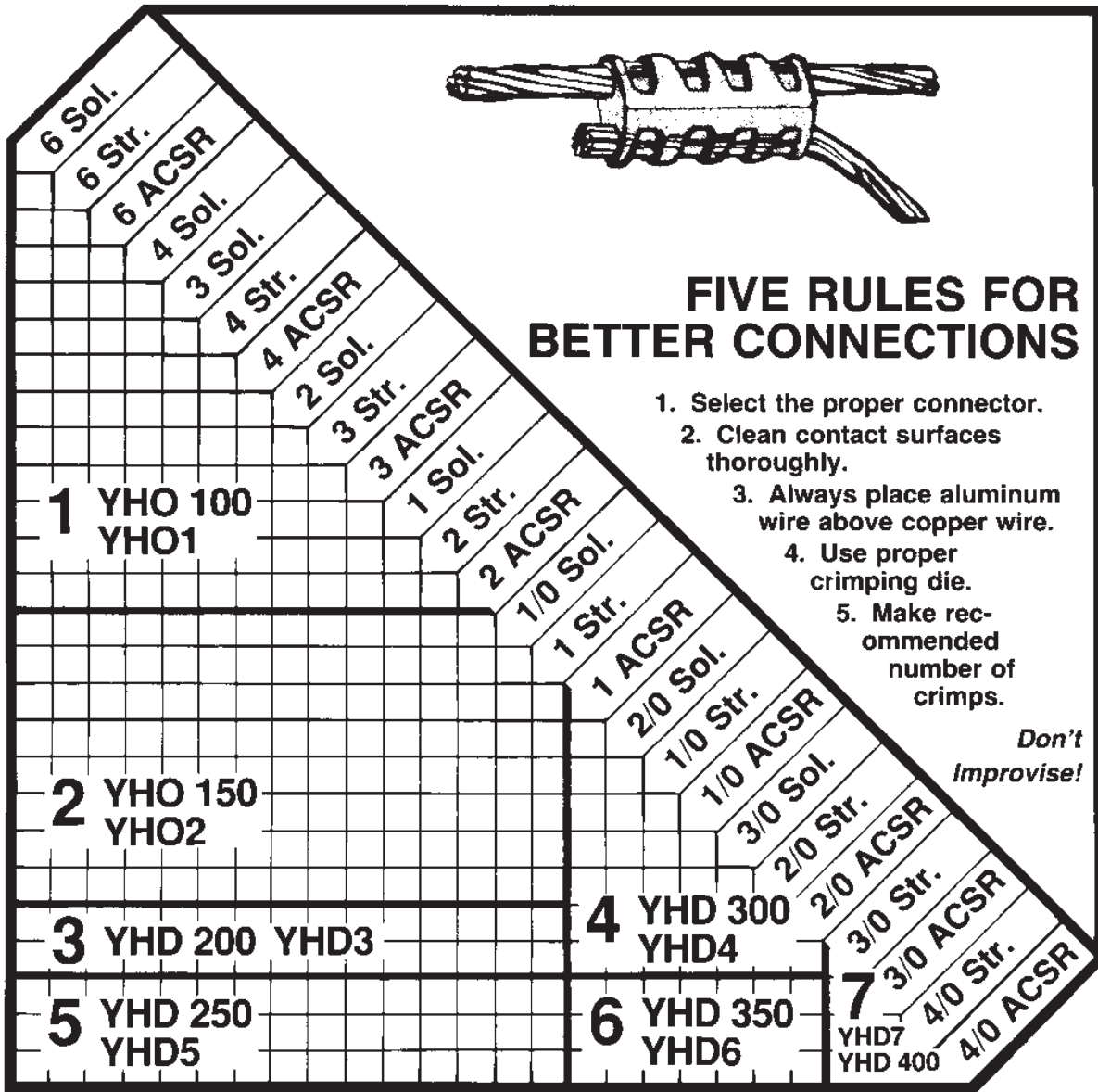

H-25

**For Compression  
Tap Connectors  
BURNDY® HYCRIMP™  
and LOKTAP™**

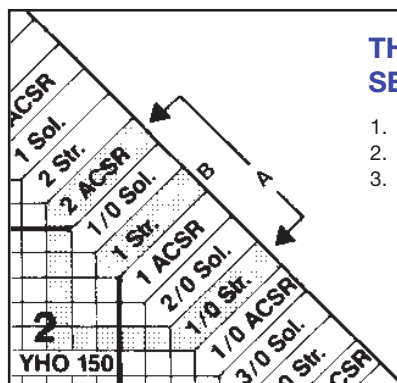

**THREE SIMPLE  
SELECTION STEPS**

1. Follow down from the smaller wire.
2. Across from the larger wire.
3. Intersection is in the area of the proper connector.

Example:

- A. For #2 ACSR to #1/0 Str. select No. 2 connector.

TYPES YHO & YHD

HYCRIMP™

Line Tap for Copper, Aluminum or ACSR and Compact Conductors

Wide range, universal and reversible figure H shaped aluminum connector. Conductors are separated by the shape of the connector. Bendable tabs secure both run and tap conductors freeing the linemans hands to work with the installation tool. Massive

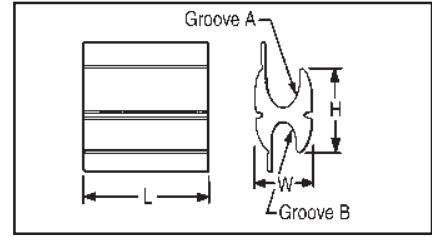

RUS Accepted

aluminum design minimizes corrosion due to galvanic corrosion. Prefilled with PENETROX™ joint compound and individual-

ly packaged. Conductor ranges and tooling clearly printed on connector and package.

H-26

Handtool or Hydraulic 7 Connector Program															
Catalog Number	① Code No.	Conductors (See Below for Compact Conductors)									Dimensions			Installation Data	
		Groove A (Run)				Groove B (Tap)				Die Index				Tool, Die Set Catalog No. & (No. of Crimps)	
		Wire Diameter Range	Sol.	Str.	ACSR	Wire Diameter Range	Sol.	Str.	ACSR		H	L	W	MD7-8	Y35, Y750, Y45†, Y46‡
YHO-100	1	.162 - .332	#6 - #1	#6 - #1; 7 Str.	#6 - #2	.162 - .332	#6 - #1	#6 - #1, 7 Str.	#6 - #2	1.12	1.25	.70	0	(4)	U-0 (2)
YHO-150	2	.260 - .419	#1 - 2/0	#3.3 Str. - 2/0	#3 - 1/0	.162 - .332	#6 - 1/0	#6 - 1, 19 Str.	#6 - #2	1.12	1.50	.70	0	(5)	U-0 (2)
YHD-200	3	.398 - .470	3/0 - 4/0	2/0 - 3/0	1/0 - 2/0	.162 - .332	#6 - 1/0	#6 - #1, 19 Str.	#6 - #2	1.44	1.62	.89	D3	(5)	UD3 (2)
YHD-250	5	.475 - .563	250 - 300	4/0	3/0 - 4/0	.162 - .332	#6 - 1/0	#6 - #1, 19 Str.	#6 - #2	1.47	1.62	.89	D3	② (5)	UD3 (2)
YHD-300	4	.336 - .470	2/0 - 4/0	#1, 3 Str. - 3/0	#1 - 2/0	.336 - .447	2/0 - 3/0	#1, 3 Str. - 2/0	#1 - 2/0	1.42	1.88	.89	D3	(5)	UD3 (2)
YHD-350	6	.461 - .563	250 - 300	3/0 - 4/0	3/0 - 4/0	.338 - .447	2/0 - 3/0	#1, 3 Str. - 2/0	#1 - 2/0	1.42	2.25	.89	D3	(7)	UD3 (3)
YHD-400	7	.461 - .563	250 - 200	3/0 - 4/0	3/0 - 4/0	.461 - .563	250 - 300	3/0 - 4/0	3/0 - 4/0	1.49	2.50	.89	D3	(7)	UD3 (3)

Compact Conductors															
Catalog Number	① Code No.	Groove A (Run)				Groove B (Tap)				Dimensions			Die Index	Installation Data	
		Wire Diameter Range	Compact ACSR	Compact CU or AL	Wire Diameter Range	Compact ACSR	Compact CU or AL	MD6-8	Y35, Y750, Y45†, Y46‡						
		Wire Diameter Range	Sol.	Str.	ACSR	Wire Diameter Range	Sol.	Str.	ACSR	H	L	W	MD6-8	Y35, Y750, Y45†, Y46‡	
YHO-100	1	.162 - .336	#6 - #3	#6 - #1	.162 - .268	#6 - #3	#6 - #1	1.12	1.25	.70	0	(4)	U-0 (2)		
YHO-150	2	.260 - .414	#2 - 1/0	#2 - 2/0	.162 - .332	#6 - #1	#6 - #1	1.12	1.50	.70	0	(5)	U-0 (2)		
YHD-200	3	.398 - .470	2/0 - 3/0	3/0	.162 - .332	#6 - #1	#6 - #1	1.44	1.62	.89	D3	(5)	UD3 (2)		
YHD-250	5	.475 - .563	4/0 - 266 (18/1)	4/0 - 266	.162 - .332	#6 - #1	#6 - #1	1.47	1.62	.89	D3	② (5)	UD3 (2)		
YHD-300	4	.336 - .470	1/0 - 3/0	1/0 - 3/0	.338 - .477	1/0 - 3/0	1/0 - 3/0	1.42	1.88	.89	D3	(5)	UD3 (2)		
YHD-350	6	.461 - .563	3/0 - 266 (18/1)	4/0 - 266	.338 - .447	1/0 - 2/0	1/0 - 3/0	1.42	2.25	.89	D3	(7)	UD3 (3)		
YHD-400	7	.461 - .563	3/0 - 266 (18/1)	4/0 - 266	.461 - .563	3/0 - 266 (18/1)	4/0 - 266	1.49	2.50	.89	D3	(7)	UD3 (3)		

Hydraulic Tool Only 4 Connector Program																
Catalog Number	① Code No.	Conductors (See Below for Compact Conductors)									Dimensions			Die Index	Installation Data	
		Groove A (Run)				Groove B (Tap)				Tool, Die Set Catalog No. & (No. of Crimps)						
		Wire Diameter Range	Sol.	Str.	ACSR	Wire Diameter Range	Sol.	Str.	ACSR	H	L	W	Y35, Y750, Y45†, Y46‡			
YHO-125		.162 - .398	#6 - 2/0	#6 - 1/0	#6 - 1/0	.162 - .332	#6 - 1/0	#6 - #1, 19 Str.	#6 - #2	1.15	1.62	.70	0	U-0 (2)		
YHD-250		.338 - .563	2/0 - 300	#1.3 Str. - 4/0	#1 - 4/0	.162 - .332	#6 - 1/0	#6 - #1, 19 Str.	#6 - #2	1.47	1.62	.89	D3	UD3 (2)		
YHD-350		.338 - .563	2/0 - 300	#1, 3 Str. - 4/0	#1 - 4/0	.338 - .477	2/0 - 3/0	#1, 3 Str. - 2/0	#1 - 2/0	1.42	2.50	.89	D3	UD3 (3)		
YHD-400		.426 - .563	4/0 - 300	3/0 - 4/0	2/0 - 4/0	.426 - .563	4/0 - 300	3/0 - 4/0	2/0 - 4/0	1.49	2.50	.89	D3	UD3 (3)		

Compact Conductors															
Catalog Number	Wire Diameter Range	Groove A (Run)			Groove B (Tap)			Dimensions			Die Index	Installation Data			
		Compact ACSR	Compact CU or AL	Wire Diameter Range	Compact ACSR	Compact CU or AL	Y35, Y750, Y45†, Y46‡								
		Sol.	Str.	ACSR	Sol.	Str.	ACSR	H	L	W	Y35, Y750, Y45†, Y46‡				
YHO-125	.162 - .398	#6 - 1/0	#6 - 2/0	.162 - .332	#6 - #1	#6 - #1	1.15	1.62	.70	0	U-0 (2)				
YHD-250	.338 - .563	1/0 - 266 (18/1)	1/0 - 266	.162 - .332	#6 - #1	#6 - #1	1.47	1.62	.89	D3	UD3 (2)				
YHD-350	.338 - .563	1/0 - 266 (18/1)	1/0 - 266	.336 - .477	1/0 - 2/0	1/0 - 3/0	1.42	2.25	.89	D3	UD3 (3)				
YHD-400	.426 - .563	3/0 - 266 (18/1)	3/0 - 266	.426 - .563	3/0 - 266 (18/1)	3/0 - 266	1.49	2.50	.89	D3	UD3 (3)				

† U Die with adapter PT-6515  
‡ U Die with adapter PUADD.

① See page H-25 for Seven Connector Selector Chart.  
② Permanent dies in tool install all sizes.

**TYPES YHN & YHR**

**HYCRIMP™**

Line Tap for Copper, Aluminum or ACSR and Compact Conductors

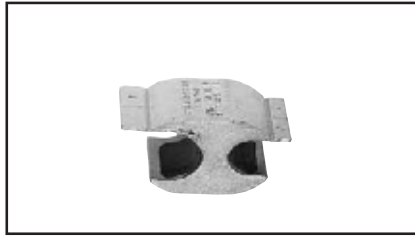

RUS Accepted

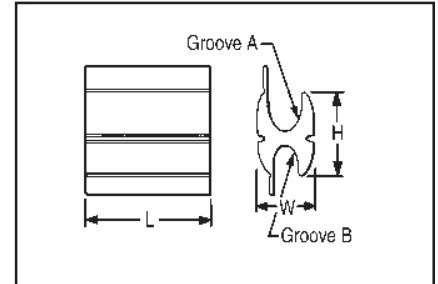

Catalog Number	N Die Connectors*										Installation Data				
	Conductors (See Below for Compact Conductors)								Dimensions			Die Index	Tool, Die Set Catalog No. & (No. of Crimps)		
	Groove A (Run)				Groove B (Tap)								Y35, Y750	Y45	Y46
	Wire Diameter Range	Str.	ACSR	Wire Diameter Range	Sol.	Str.	ACSR	H	L	W	Y35, Y750	Y45	Y46		
YHN-450	.522 - .750	4/0 - 400	4/0 - 397 (18/1)	.522 - .750	336 - 477	4/0 - 400	4/0 - 397 (18/1)	2.05	3.50	1.25	N	U-N (3)	S-N (3)	P-N (3)	
YHN-500	.522 - .815	4/0 - 500	4/0 - 477 (18/1)	.160 - .450	#6 - 3/0	#6 - 2/0	#6 - 2/0	2.00	1.62	1.28	N	U-N (2)	S-N (2)	P-N (2)	
YHN-525	.522 - .814	4/0 - 500	4/0 - 477 (18/1)	.522 - .814	—	4/0 - 500	4/0 - 477 (18/1)	1.824	4.50	1.23	N	U-N (3)	S-N (3)	P-N (3)	
YHN-550	.573 - .815	250 - 500	266 - 477 (18/1)	.410 - .505	3/0 - 300	2/0 - 4/0	2/0 - 4/0	1.96	2.00	1.28	N	U-N (2)	S-N (2)	P-N (2)	
YHN-600	.573 - .815	250 - 500	266 - 477 (18/1)	.570 - .685	336 - 400	250 - 350	266 - 336.4 (18/1)	2.00	3.50	1.28	N	U-N (3)	S-N (3)	P-N (3)	

Catalog Number	Compact Conductors						Dimensions			Die Index	Installation Data		
	Groove A (Run)			Groove B (Tap)							Tool, Die Set Catalog No. & (No. of Crimps)		
	Wire Diameter Range	Compressed ACSR	Compact CU or AL	Wire Diameter Range	Compressed ACSR	Compact CU or AL	H	L	W	Y35, Y750	Y45	Y46	
	YHN-450	.522 - .750	226 - 477 (18/1)	250 - 500	.522 - .750	266 - 477 (18/1)	250 - 500	2.05	3.50	1.25	N	U-N (3)	S-N (3)
YHN-500	.522 - .815	266 - 556	250 - 556	.160 - .450	#6 - 2/0	#6 - 3/0	2.00	1.62	1.28	N	U-N (2)	S-N (2)	P-N (2)
YHN-525	.522 - .814	266.8 - 556.5	250 - 556	.522 - .814	266.8 - 556.5	250 - 556	1.824	4.50	1.23	N	U-N (3)	S-N (3)	P-N (3)
YHN-550	.573 - .815	300 - 556	300 - 556	.410 - .565	2/0 - 266	3/0 - 266	1.96	2.00	1.28	N	U-N (2)	S-N (2)	P-N (2)
YHN-600**	.573 - .815	300 - 556	300 - 556	.570 - .685	300 - 397	300 - 397	2.00	3.50	1.28	N	U-N (3)	S-N (3)	P-N (3)

Catalog Number	R Die Connectors*										Installation Data			
	Conductors (See Below for Compact Conductors)								Dimensions			Die Index	Tool, Die Set Catalog No. & (No. of Crimps)	
	Groove A (Run)				Groove B (Tap)								Y45	Y46
	Wire Diameter Range	Str.	ACSR	Wire Diameter Range	Sol.	Str.	ACSR	H	L	W	Y45	Y46		
YHR-700	.666 - .893	336 - 600	300 - 556 (18/1)	.398 - .684	3/0 - 350	2/0 - 350	1/0 - 336.4 (18/1)	3.04	3.50	1.74	KR	S-KR (3)	P-KR (3)	
YHR-750	.666 - .893	336 - 600	300 - 556 (18/1)	.666 - .893	—	300 - 600	300 - 556 (18/1)	3.04	4.62	1.74	KR	S-KR (4)	P-KR (4)	
YHR-800	.879 - 1.108	600 - 900	556.5 (18/1) - 795 (26/7)	.398 - .684	3/0 - 350	2/0 - 350	1/0 - 336.4 (18/1)	3.05	3.50	1.74	KR	S-KR (3)	P-KR (3)	
YHR-850	.879 - 1.108	600 - 900	556.5 (18/1) - 795 (26/7)	.666 - .893	—	336 - 600	300 - 556 (18/1)	3.04	4.62	1.74	KR	S-KR (4)	P-KR (4)	
YHR-900	.879 - 1.108	600 - 900	556.5 (18/1) - 795 (26/7)	.879 - 1.108	—	600 - 900	556.5 (18/1) - 795 (26/7)	2.97	4.62	1.74	KR	S-KR (4)	P-KR (4)	
YHR-950	.666 - 1.165	336.4 - 1000	556.5 (18/1) - 954 (45/7)	.666 - 1.165	—	336.4 - 1000	336.4 (18/1) - 954 (45/7)	3.14	6.00	1.66	KR	S-KR (5)	P-KR (5)	

Catalog Number	Compact Conductors						Dimensions			Die Index	Installation Data	
	Groove A (Run)			Groove B (Tap)							Tool, Die Set Catalog No. & (No. of Crimps)	
	Wire Diameter Range	Compressed ACSR	Compact CU or AL	Wire Diameter Range	Compressed ACSR	Compact CU or AL	Y45	Y46				
	YHR-700	.666 - .893	397 - 636	477 - 636	.398 - .684	2/0 - 397 (18/1)	3/0 - 397.5	3.04	3.50	1.74	KR	S-KR (3)
YHR-750	.666 - .893	397 - 636	477 - 636	.666 - .893	397 - 636	477 - 636	3.04	4.62	1.74	KR	S-KR (4)	P-KR (4)
YHR-800	.879 - 1.108	795 - 954	795 - 954	.398 - .684	2/0 - 397 (18/1)	3/0 - 397.5	3.05	3.50	1.74	KR	S-KR (3)	P-KR (3)
YHR-850	.879 - 1.108	795 - 954	795 - 954	.666 - .893	397 - 636	477 - 636	3.04	4.62	1.74	KR	S-KR (4)	P-KR (4)
YHR-900	.879 - 1.108	795 - 954	795 - 954	.879 - 1.108	795 - 954	795 - 954	2.97	4.62	1.74	KR	S-KR (4)	P-KR (4)
YHR-950	.666 - 1.165	—	—	.666 - 1.165	—	—	3.14	6.00	1.66	KR	S-KR (5)	P-KR (5)

\* HYCRIMP™ connectors can be installed with competitive R dies.

\*\* Die Index S-T and S-Z may also be used on sizes 700-900 only. S-KR required for 950 and S-Z.

Blue highlighted items are industry standard and most frequently ordered.

LOKTAP™

LOKTAP™ compression connectors are high quality, range-taking devices which accommodate combinations of aluminum to copper, and aluminum to aluminum conductors. BURNDY® seven connector program accommodates a conductor range from #6 Sol. to 4/0 ACSR. In addition, LOKTAP™ products feature a “C” groove on both sides

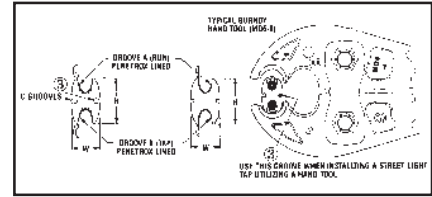
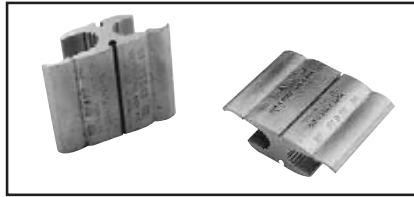

of the connector for use in street lighting applications from #14 Sol. to #10 Sol.

LOKTAP™ connectors are designed to be installed with BURNDY® mechanical or hydraulic tools and matching O and D<sup>3</sup> die set.

H-28

Handtool or Hydraulic 7 Connector Program ①															
Catalog Number	① Code No.	Conductors (See Below for Compact Conductors)									Dimensions			Installation Data	
		Groove A (Run)			Groove B (Tap)			Die Index	Tool, Die Set Catalog No. & (No. of Crimps)						
		Wire Diameter Range	Sol.	Str.	ACSR	Wire Diameter Range	Sol.		Str.	ACSR	H	L	W	MD7, MD6	Y35, Y750, Y45†, Y46‡
YHO-1	1	.162 - .332	#6 - #1	#6 - #1, 7 Str.	#6 - #2	.162 - .332	#6 - #1	#6 - #1, 7 Str.	#6 - #2	1.11	1.25	.67	0	(4)	U-0 (2)
YHO-2	2	.260 - .419	#1 - 2/0	#3.3 Str. - 2/0	#3 - 1/0	.162 - .332	#6 - 1/0	#6 - #1, 19 Str.	#6 - #2	1.12	1.50	.64	0	(5)	U-0 (2)
YHD-3	3	.398 - .470	3/0 - 4/0	2/0 - 3/0	1/0 - 2/0	.162 - .332	#6 - 1/0	#6 - #1, 19 Str.	#6 - #2	1.47	1.88	.76	D3	(5)	UD3 (2)
YHD-5	5	.475 - .563	250 - 300	4/0	3/0 - 4/0	.162 - .332	#6 - 1/0	#6 - #1, 19 Str.	#6 - #2	1.47	1.88	.87	D3	(5)	UD3 (2)
YHD-4	4	.336 - .470	2/0 - 4/0	#1, 3 Str. - 3/0	#1 - 2/0	.336 - .477	2/0 - 3/0	#1, 3 Str. - 2/0	#1 - 2/0	1.42	1.88	.83	D3	(5)	UD3 (2)
YHD-6	6	.461 - .563	250 - 300	3/0 - 4/0	3/0 - 4/0	.336 - .447	2/0 - 3/0	#1, 3 Str. - 2/0	#1 - 2/0	1.42	2.25	.83	D3	(6)	UD3 (3)
YHD-7	7	.461 - .563	250 - 300	3/0 - 4/0	3/0 - 4/0	.461 - .563	250 - 300	3/0 - 4/0	3/0 - 4/0	1.40	2.52	.84	D3	(7)	UD3 (3)
YHO-10**	—	.232 - .419**	#2 - #1**	#4 - 2/0**	#4 - 1/0	.232 - .419**	#2 - #1**	#4 - 2/0**	#4 - 1/0	1.18	1.50	.68	0	(4)	U-0 (2)

Compact Conductors													
Catalog Number	① Code No.	Groove A (Run)			Groove B (Tap)			Dimensions			Installation Data		
		Wire Diameter Range	Compact ACSR	Compact CU or AL	Wire Diameter Range	Compact ACSR	Compact CU or AL						Die Index
		H	L	W	MD6	Y35, Y750, Y45†, Y46‡							
YHO-1	1	.162 - .332	#6 - #1	#6 - #1	.162 - .332	#6 - #1	#6 - #1	1.11	1.25	.67	0	(4)	U-0 (2)
YHO-2	2	.260 - .419	#2 - 1/0	#2 - 2/0	.162 - .332	#6 - #1	#6 - #1	1.12	1.50	.64	0	(5)	U-0 (2)
YHD-3	3	.398 - .470	2/0 - 3/0	3/0	.162 - .332	#6 - #1	#6 - #1	1.47	1.88	.76	D3	(5)	UD3 (2)
YHD-5	5	.475 - .563	4/0 - 266 (18/1)	4/0 - 256	.162 - .332	#6 - #1	#6 - #1	1.47	1.88	.87	D3	(5)	UD3 (2)
YHD-4	4	.336 - .470	1/0 - 3/0	1/0 - 3/0	.338 - .447	1/0 - 2/0	1/0 - 3/0	1.42	1.88	.83	D3	(5)	UD3 (2)
YHD-6	6	.461 - .563	3/0 - 266 (18/1)	4/0 - 266	.338 - .447	1/0 - 2/0	1/0 - 3/0	1.42	2.25	.83	D3	(6)	UD3 (3)
YHD-7	7	.461 - .563	3/0 - 266 (18/1)	4/0 - 266	.461 - .563	3/0 - 266 (18/1)	4/0 - 266	1.40	2.52	.84	D3	(7)	UD3 (3)
YHO-10**	—	.232 - .419**	#4 - 2/0	#2 - 2/0**	.232 - .419**	#4 - 2/0	#2 - 2/0**	1.18	1.50	.68	0	(4)	U-0 (2)

Hydraulic Tool Only 4 Connector Program														
Catalog Number	Conductors (See Below for Compact Conductors)									Dimensions			Installation Data	
	Groove A (Run)			Groove B (Tap)			Die Index	Tool, Die Set Catalog No. & (No. of Crimps)						
	Wire Diameter Range	Sol.	Str.	ACSR	Wire Diameter Range	Sol.		Str.	ACSR	H	L	W	Y35, Y750, Y45†, Y46‡	
—	.162 - .398	#6 - 2/0	#6 - 1/0	#6 - 1/0	.162 - .332	#6 - 1/0	#6 - #1, 19 Str.	#6 - #2	1.15	1.62	.70	0	U-0 (2)	
YHD-5	.336 - .563	2/0 - 300	#1.3 Str. - 4/0	#1 - 4/0	.162 - .332	#6 - 1/0	#6 - #1, 19 Str.	#6 - #2	1.47	1.88	.87	D3	UD3 (2)	
YHD-6	.336 - .563	2/0 - 300	#1, 3 Str. - 4/0	#1 - 4/0	.336 - .477	2/0 - 3/0	#1.3 Str. - 2/0	#1 - 2/0	1.42	2.25	.83	D3	UD3 (3)	
YHD-7	.414 - .563	4/0 - 300	3/0 - 4/0	2/0 - 4/0	.461 - .563	4/0 - 300	3/0 - 4/0	2/0 - 4/0	1.40	2.52	.86	D3	UD3 (3)	

Compact Conductors													
Catalog Number	Groove A (Run)			Groove B (Tap)			Dimensions			Installation Data			
	Wire Diameter Range	Compact ACSR	Compact CU or AL	Wire Diameter Range	Compact ACSR	Compact CU or AL						Die Index	Tool, Die Set Catalog No. & (No. of Crimps)
	H	L	W	Y35, Y750, Y45†, Y46‡									
—	.162 - .398	#6 - 1/0	#6 - 2/0	.162 - .332	#6 - #1	#6 - #1	1.15	1.62	.70	0	U-0 (2)		
YHD-5	.336 - .563	1/0 - 266 (18/1)	1/0 - 256	.162 - .332	#6 - #1	#6 - #1	1.47	1.88	.87	D3	UD3 (2)		
YHD-6	.336 - .563	1/0 - 266 (18/1)	1/0 - 256	.336 - .447	1/0 - 2/0	1/0 - 3/0	1.42	2.25	.83	D3	UD3 (3)		
YHD-7	.414 - .563	3/0 - 266 (18/1)	3/0 - 256	.414 - .563	3/0 - 266 (18/1)	3/0 - 266	1.40	2.52	.86	D3	UD3 (3)		

\*\* YHO-10: These ranges are for aluminum only. Use only #4 Str. concentric copper tap.

† U Die with adapter PT-6515.

‡ U Die with adapter PUADP-1.

① See page H-25 for Seven Connector Selector Chart.

② PERMANENT DIES IN TOOL INSTALL ALL SIZES.

③ “C” grooves accommodate #10 Sol. - #14 Sol. RANGE., 116 in.-.064 in. No “C” grooves on CAT. NO. YHO125. When utilizing “C” groove(s) apply PENETROX™ A13 prior to wire

installation. When utilizing two (2) “C” groove taps, installation to be made with HYDRAULIC TOOL ONLY. All four (4) grooves CANNOT be utilized if using a hand tool. When hand tool is used, only one (1) “C” groove can be utilized and connector MUST be positioned as shown in FIG.5

**TYPE YCT**

**HYTEE**

T-Tap for Copper

One-piece, copper compression tap connector with U-shaped run element and tubular tap for joining hard and medium-hard drawn copper. Preformed run element simplifies installation on larger conductors. Uses same die as equivalent full-tension sleeve.

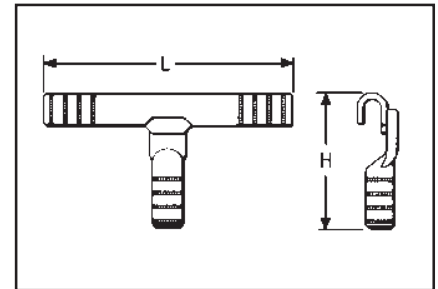

Conductors			H	L	Run			Tap		
Catalog Number	Run	Tap			Die Index	Tools, Die Set Catalog No., & (Crimps per End)		Die Index	Tools, Die Set Catalog No., & (Crimps per End)	
						MD7, MD6	Y35, Y750, Y45†, Y46‡		MD6	Y35, Y750, Y45†, Y46‡
YCT2626	2/0 (7, 12, 19)	2/0 (7, 12, 19)	3.26	5.62	166	W166 (4)	U166/U459 (2)	166	W166 (6)	U-166 (3)
YCT2828	4/0 (7, 12, 19)	4/0 (7, 12, 19)	4	5.72	168		U168 (2)	168		U-168 (3)

† U Die with adapter PT-6515.  
‡ U Die with adapter PUADP-1.

H-29

**TYPE YOT**

**HYTEE**

T-Tap for Copper

Cast copper T-tap connector with two-piece line element and tubular tap for joining hard and medium drawn copper. Design simplifies installation on large conductors. Uses same die as equivalent sleeve.

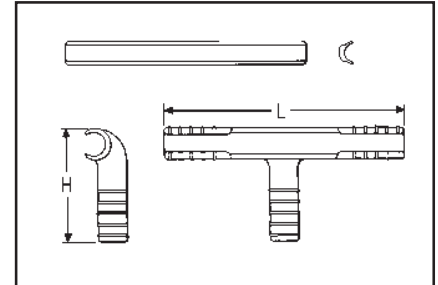

Conductors			H	L	Run			Tap		
Catalog Number	Run	Tap			Die Index	Tools, Die Set Catalog No., & (Crimps per End)		Die Index	Tools, Die Set Catalog No., & (Crimps per End)	
						Y35, Y750, Y45†, Y46‡	Y60B		Y35, Y750, Y45†, Y46‡	Y60BHU
YOT3434	500 (19, 37)	500 (19, 37)	4.82	10.38	210	U210 (6)	L210 (2)	210	U210 (6)	L210 (2)

† U Die with adapter PT-6515.  
‡ U Die with adapter PUADP-1.

Blue highlighted items are industry standard and most frequently ordered.

**TYPE YTU-R-R**

**T-TAP**

For Combinations of Aluminum, Copper, ACSR, 6201, 5005 Compressed and Compact Conductors

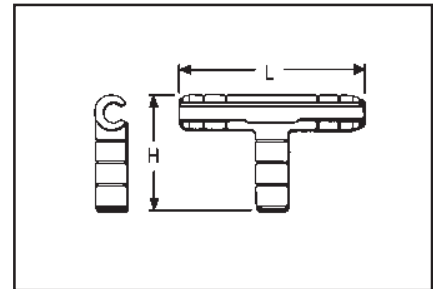
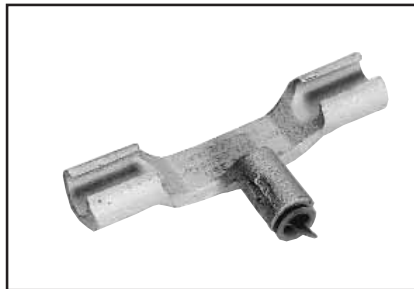

One-piece heavy-wall aluminum compression tap connector for secondary service drop and transformer tap to primary or secondary. Connector can be gripped in tool for easy installation. Pre-filled with PENETROX™ joint compound.

H-30

Catalog Number	Run			Tap			H	L	Die Index	Run		Tap				
	ACSR, 6201, 5005	Aluminum	Copper	ACSR, 6201, 5005	Aluminum	Copper				Tools, Die Set Catalog Number, & (Crimps per End)		Die Index	Tools, Die Set Catalog Number, & (Crimps per End)			
										MD7, MD6	Y35, Y750, Y45†, Y46‡		MD7, MD6	Y35, Y750, Y45, Y46‡		
YTU25R4W	1/0 80 (8-1)	1/0 (7, 19)	1/0 (7, 12, 19)	#6	#4 (7) #4 SLD	#4 (7) #4 Sol.	2-3/8	4-7/8	C	W-C (2)	U-C (1)*	BG	BG (3) W-BG (1)*	U-BG (1)*		
YTU25R25R				1/0 80 (8-1)	1/0 (7, 19)	—										
YTU26R26R	2/0	2/0 (7, 19)	2/0 (7, 12, 19)	2/0	2/0 (7, 19)	2/0 (7, 12, 19)	3-3/8	7	L	W-L (4)	U-L (2)	L	—	U-L (2)		
YTU27R27R	3/0	3/0 (7, 19)	3/0 (7, 12, 19)	3/0	3/0 (7, 19)	3/0 (7, 12, 19)										
YTU28R28R	4/0	4/0 (7, 19)	4/0 (7, 12, 19)	4/0	4/0 (7, 19)	4/0 (7, 12, 19)										
YTU30R30R	266.8 (18-1, 26-7, 6-7)	266.7 (7, 19, 37) 250 (19, 37) 300 (19, 37)	250 (12, 19, 37) 300 (19, 37)	266.8 (18-1, 26-7, 6-7)	266.7 (7, 19, 37) 250 (19, 37) 300 (19, 37)	250 (12, 19, 37)	4-3/8	8-3/4	M	—	U-M (3)	M	—	U-M (3)		
YTU321R2R	300 (26-7) 336.4 (18-1)	350 (19, 37) 336.4 (19, 37)	350 (19, 37)	2	2 (7 Str.)	2 (3, 7 Str.)	2-5/8	6-5/8				BG	BG (3) W-BG (1)*	U-BG (1)*		
YTU321R26R				2/0	2/0 (7, 19)	2/0 (7, 12, 19)	3-1/2	8-5/8				L	—	U-L (2)		
YTU321R27R				3/0	3/0 (7, 19)	3/0 (7, 12, 19)										
YTU321R28R				4/0	4/0 (7, 19)	4/0 (7, 12, 19)	M	—				U-M (3)				
YTU321R321R				336.4 (18-1) 300 (26-7)	336.4 (19, 37) 350 (19, 37)	350 (19, 37)										
YTU33R26R				336.4 (30.7) (26-7)	397.5 (19, 37) 400 (19, 37)	400 (19, 37)	2/0	2/0 (7, 19)				2/0 (7, 12, 19)	3-1/2	8-5/8	L	U-L (2)
YTU33R28R							4/0	4/0 (7, 19)				4/0 (7, 12, 19)				
YTU33R33R							336.4 (30.7) (26-7) 397.5 (18-1)	397.5 (19, 37) 400 (19, 37)				400 (19, 37)	4-3/8	8-3/4	M	—

\* Multiple crimp die set, makes more than one crimp per tool compression. Figure indicates number of compressions.

† U Die with adapter PT-6515

‡ U Die with adapter PUADP-1.

Blue highlighted items are industry standard and most frequently ordered.

**TYPE YTA-R-2N**

**DISCONNECTABLE T-TAP (WITH PAD)**

For Copper, Aluminum, ACSR, 6201, 5005, Compressed and Compact Conductors

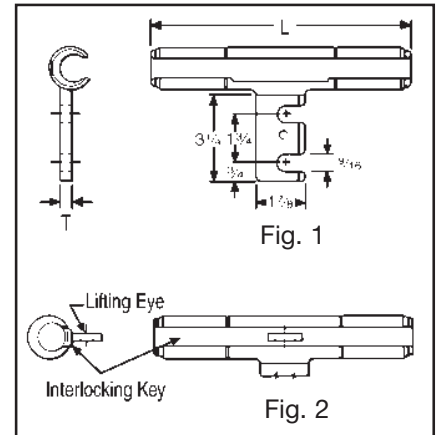

Aluminum primary T-tap connector with slotted tap pad designed for easy disconnecting of tap conductor. Tap pad accommodates compression terminals Types YKA-R-2N and YKA-A-2N, and has positioning socket for proper alignment. On sizes larger than 336.4 ACSR, the YTA-R-2N run element has two-piece interlocking-key with lifting eye that simplifies hotline installations. Catalog number does not include mating terminal.

H-31

Catalog Number	ACSR, 6201, 5005	Copper	Aluminum	Fig. No.	L	T	Die Index	Tools, Die Set Catalog Number, & (Number of Crimps per End)									
								MD7, MD6	Y35, Y750	Y45†	Y46‡	Y48B	Y60BHU				
YTA2R-2N	2	2 (3, 7) 1 (7)	2 (7) 1 (7)	1	6-1/8	3/8	BG or 243	BG (2) W-BG (1)* W243 (2)	U-BG (1)* U243 (1)								
YTA25R-2N	1/0	1/0 (7, 12, 19)	1/0 (7, 19)				7-7/8	1/2	659 C, 247	W-C (4) W247 (1)	U659 (1) U-C (1)* U247(1)						
YTA26R-2N	2/0	2/0 (7, 12, 19)	2/0 (7, 19)						9-1/2	M	L or 251	W-L (4)	U-L (2) U251 (3)				
YTA27R-2N	3/0	3/0 (7, 12, 19)	3/0 (7, 19)				13-1/8	608			—	—	U-M (3) U317 (4)				
YTA28R-2N	4/0	4/0 (7, 12, 19)	4/0 (7, 19)										16-1/4	319	—	—	U-M (5)
YTA321R-2N	300 (26-7) 336.4 (18-1)	350 (19, 37)	336.4 (19, 37, 61) 350 (19, 37, 61)		16-1/2	3/4	—	—	U608 (9)			C608 (3)					L608 (3)
YTA33R-2N	336.4 (26-7, 30-7) 397.5 (18-1)	400 (19, 37)	397.5 (19, 37, 61) 400 (19, 37, 61)						2	342	—	—	—	S292 (9) S319 (9)	P292 (9) P319 (9)	C292 (3) C319 (3)	L292 (3) L319 (3)
YTA361R-2N	477 (18-1)	—	556.6 (19, 37)		YTA43R-2N	—	—	—					—	—	—	—	—
YTA37R-2N	477 (24-7, 26-7, 30-7)		636 (37) 650 (61)						795 (37, 61)	—	—	—					
YTA39R-2N	556.5 (24-7, 26-7)	605 (30-19) 605 (30-9) 636 (24-7, 26-7, 30-19) 666.6 (24-7)	—		YTA391A-2N	—	—	—	—				—	—	—	—	
YTA391A-2N	—	—	—	—	—	—	—	—	—	—	—	—					

\* Multiple crimp die set, makes more than one crimp per tool compression. Figure indicates number of compressions.  
 † U Die with adapter PT-6515.  
 ‡ U Die with adapter PUADP-1.

Blue highlighted items are industry standard and most frequently ordered.



## TYPES YKA-R-2N & YKA-A-2N

### DISCONNECTABLE TERMINAL (WITH FIXED HARDWARE)

For Copper, Aluminum, ACSR, 6201, 5005, Compressed and Compact Conductors

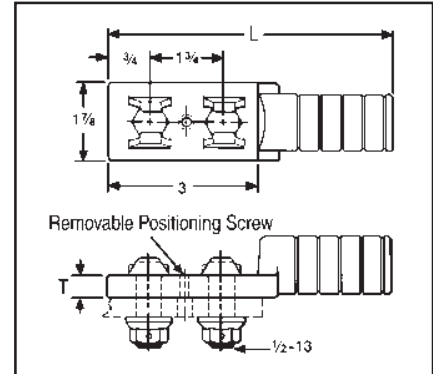
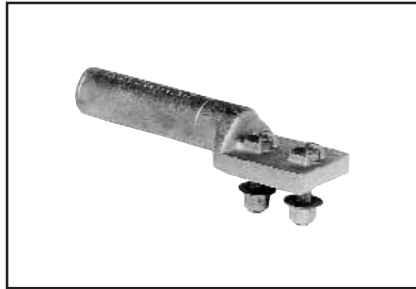

Aluminum compression terminal with fixed hardware and positioning pin for making disconnectable tap or jumper connections. Used with slotted YTA-R-2N T-tap or YSA-R-2N terminal. Supplied with aluminum bolts and washer-face, self locking nuts. Prefilled with PENETROX™ joint compound and capped.

H-32

Catalog Number	ACSR, 6201, 5005	Copper	Aluminum	L	T	Bolt Length	Die Index	Tools, Die Set Catalog Number, & (Number of Crimps)					
								MD7, MD6	Y35, Y750	Y45†	Y46‡	Y48B	Y60BHU
YKA2R-2N	2	1 (7) 2 (3, 7)	1 (7) 2 (7)	5-1/2	3/8	1-3/4	BG or 243	BG (8) W-BG (4)* W243 (4)	U-BG (3)* U243 (2)	—	—	—	—
YKA25R-2N	1/0	1/0 (7, 19)	1/0 (7, 19)	5-5/8			C or 659	W-C (6) —	U-C (3)* U659 (2)	—	—	—	—
YKA26R-2N	2/0	2/0 (7, 19)	2/0 (7, 19)	6			L or 251	—	U-L (2) U251 (3)	—	—	—	—
YKA27R-2N	3/0 110.8 (12-7)	3/0 (7, 19)	3/0 (7, 19)				M or 317	—	U-M (3) U317 (4)	—	—	—	—
YKA28R-2N	4/0	4/0 (7, 19)	4/0 (7, 19)				M	—	U-M (3)	—	—	—	—
YKA30R-2N	266.8 (18-1, 6-7, 26-7)	250 (12, 19, 37) 300 (19, 37)	250 (7, 37) 266 (19)	7-1/4			352 or 579	—	—	S352 (9) S579 (9)	P352 (9) P579 (9)	C352 (3) C579 (3)	L352 (3) L579 (3)
YKA321R-2N	336.4 (18-1) 300 (26-7)	350 (19, 37)	300 (37, 61) 350 (37, 61)				M	—	U-M (3)	—	—	—	—
YKA33R-2N	336.4 (26-7, 30-7) 397.5 (18-1)	—	397.5 (19) 400 (37)				M	—	U-M (3)	—	—	—	—
YKA361R-2N	397.5 (26-7, 30-7) 477 (18-1)	—	477 (19, 37) 500 (37, 61)				342	—	—	S342 (9)	P342 (9)	C342 (3)	L342 (3)
YKA37R-2N	477 (24-7, 26-7, 30-7)	—	556.5 (19, 37)	7-3/8			3/4	2-1/2	—	—	—	—	—
YKA34CA-2N	397.5 (26-7, 30-7) 477 (18-1)	500 (19, 37)	477 (19, 37) 500 (37, 61)	9-1/2	3/4	2-1/2	—	—	—	—	—		
YKA391A-2N	—	—	795 (37, 61)	9-1/2	3/4	2-1/2	—	—	—	—	—		

\* Multiple crimp die set, makes more than one crimp per tool compression. Figure indicates number of compressions.

† U Die with adapter PT-6515

‡ U Die with adapter PUADP-1.

Blue highlighted items are industry standard and most frequently ordered.



**TYPE YSA-R-2N**

**DISCONNECTABLE TERMINAL (WITH SLOTTED PAD)**

For Copper, Aluminum, ACSR, 6201, 5005, Compressed and Compact Conductors

Aluminum compression terminal with slotted pad and positioning socket for making disconnectable tap or jumper connections. Used with YKA-R-2N fixed hardware terminal.

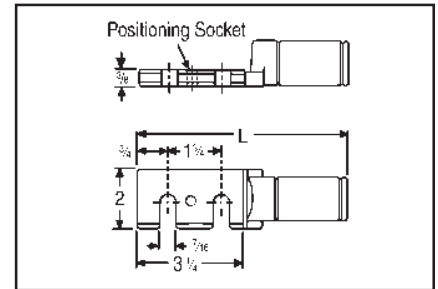
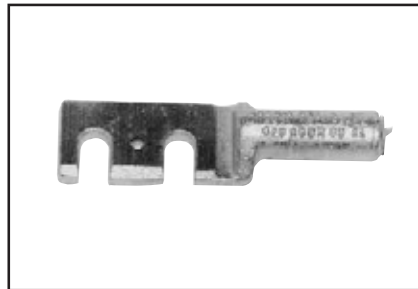

Pre-filled with PENETROX™ joint compound and capped.

Catalog Number	ACSR, 6201, 5005	Copper	Aluminum	L	Die Index	Tools, Die Set Catalog Number, & (Number of Crimps)	
						MD7, MD8	Y35, Y750, Y45†, Y46‡
YSA2R-2N	2	2 (3, 7) 1 (7)	2 (7) 1 (7)	6-1/4	BG or 243	BG (8) W-BG (4)* W243 (4)	U-BG (3)* U243 (2)
YSA25R-2N	1/0	1/0 (7, 19)	1/0 (7, 19)		C or 659	—	U-C (3)* U659 (2)
YSA26R-2N	2/0	2/0 (7, 19)	2/0 (7, 19)	6-5/8	L or 251	—	U-L U251
YSA28R-2N	4/0	4/0 (7, 19)	4/0 (7, 19)				
YSA30R-2N	266.8 (18-1, 6-7, 26-7)	250 (12, 19, 37) 300 (19, 37)	250 (37) 266.8 (7, 19)	7-3/4	M or 317	—	U-M (3) U317 (4)
YSA321R-2N	336.4 (18-1) 300 (26-7)	350 (19, 37)	300 (37, 61) 350 (37, 61)				
YSA37R-2N	477 (24-7, 26-7, 30-7)	—	556.5 (19, 37)	7-7/8	M	—	U-M (3)

\* Multiple crimp die set, makes more than one crimp per tool compression. Figure indicates number of compressions.

† U Die with adapter PT-6515  
‡ U Die with adapter PUADP-1.

H-33

**TYPE YTA-2N**

**DISCONNECTABLE T-TAP**

For Copper

Cast copper primary t-tap connector with slotted tap pad for easy disconnecting of tap conductor. Tap pad accommodates compression terminal Type YKA-2N. On sizes larger than 4/0, the YTA-2N run element has a two-piece, interlocking-key with lifting eye that simplifies hot installations. Catalog number does not include terminal or hardware.

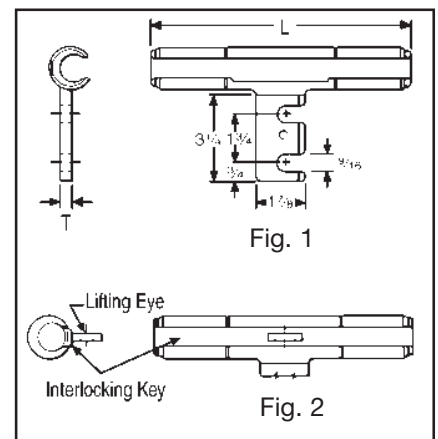

Catalog Number	Conductor	Fig. No.	C	L	T	Die Index	Tools, Die Set Catalog Number, & (Crimps per End)			
							MD7, MD6	Y35, Y750, Y45†, Y46‡	Y48B	Y60BHU
YTA2C-2N	2 (7)	1	1-1/2	5-5/8	3/8	163	W163 (3) Crimps Overlap	U163 (1)*	—	—
YTA26-2N	2/0 (7, 19)			7-3/8		166	W166 (6)	U166 (3)	—	—
YTA28-2N	4/0 (7, 12, 19)			7-5/8		168	—	U168 (4)	—	—
YTA34-2N	500 (19, 37, 61)	2	2	11-7/8	1/2	210	U210 (6)	C210 (2)	L210 (2)	

\* Multiple crimp die set, makes more than one crimp per tool compression. Figure indicates number of compressions.

† U Die with adapter PT-6515  
‡ U Die with adapter PUADP-1.

Blue highlighted items are industry standard and most frequently ordered.

## TYPE YKA-2N

### DISCONNECTABLE TERMINAL (WITH FIXED HARDWARE)

For Copper

Tin-plated copper compression terminal with fixed hardware for making disconnectable tap or jumper connections. Used with slotted YTA-2N T-tap or YSA-R-2N terminal. Supplied with tin-plated DURIMUM™ bolts and washer-face nuts.

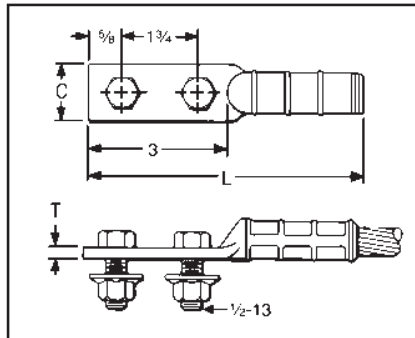

H-34

Catalog Number	Conductor	C	L	T	Die Index	Tools, Die Set Catalog Number, & (Number of Crimps)			
						MD7, MD6	Y35, Y750, Y45†, Y46‡	Y48B	Y60BHU
YKA6C-2N	6 (7)	7/8	5	3/8	163	W163 (2)	U163 (1)*	—	—
YKA2C-2N	2 (7)					Crimps Overlap			
YKA26-2N	2/0 (7, 19, 37)	1	5-1/4	1/4	166	W166 (4)	U166 (3)	—	—
YKA28-2N	4/0 (7, 12, 19, 37)	1-1/4	5-3/8	3/8	168	—	U168 (3)	C168 (1)	L168 (1)
YKA30-2N	300 (19, 37, 61)	1-1/2	5-1/2		170		U170 (5)	C170 (1)	L170 (1)
YKA34-2N	500 (19, 37, 61)	1-7/8	6-1/2	1/2	210	—	U210 (6)	C210 (2)	L210 (2)
YKA44-2N	1000 (61)	2	7-5/8	1/2	345	—	—	C345 (4)	L345 (4)

\* Multiple crimp die set, makes more than one crimp per tool compression. Figure indicates number of compressions.

† U Die with adapter PT-6515

‡ U Die with adapter PUADP-1.

Blue highlighted items are industry standard and most frequently ordered.

**TYPE YCB-R**

**STIRRUP HOT-LINE CLAMP ADAPTERS**

For Aluminum, ACSR, 6201, 5005, Compressed and Compact Conductors

Permanent compression hot-line clamp adapter with aluminum run and copper bail. Accommodates any standard copper hot-line clamp on bail elements. Permits hot-line tapping without arcing or chafing damage to aluminum conductor. Installed with standard tools and dies.

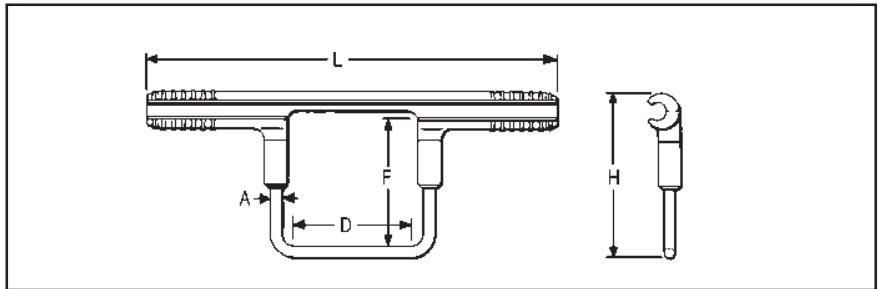

H-35

Catalog Number	Aluminum	ACSR, 6201, 5005	A	H	L	D	F	Die Index	Tools, Die Set Catalog Number, & (Crimps per End)	
									MD7, MD6	Y35, Y750, Y45†, Y46‡
YCB2R	2 Str. - 6 Sol.	2 - 4	2 Sol.	3-3/4	9	2-1/2	2-1/2	BG	BG (6) W-BG (2)*	U-BG (2)*
YCB25R	1/0 (7, 19)	1/0 - 80 (8-1)		5	9-3/4			C	W-C (4)	U-C (2)*
YCB26R	2/0 (7, 19)	2/0			L			W-L (4)	U-L (2)	
YCB27R	3/0 (7, 19)	3/0								
YCB28R	4/0 (7, 19)	4/0	1/0 Sol.	5-3/8	11-1/8	3-1/2	3-1/2	M	—	U-M (3)
YCB321R	350 (19, 37) 336.4 (19, 37)	336.4 (18-1) 300 (26-7)								
YCB33R	400 (19, 37) 397.5 (19, 37)	336.4 (26-7, 30-7) 397.5 (18-1)								
YCB35R	500 (37, 61) 477 (19, 37)	397.5 (26-7) (30-7)								
YCB361R	477 (19, 37)	477 (18-1)								

\* Multiple crimp die set, makes more than one crimp per tool compression. Figure indicates number of compressions.

† U Die with adapter PT-6515  
‡ U Die with adapter PUADP-1.

Blue highlighted items are industry standard and most frequently ordered.

## TYPES YCB-U & YCB-R-U

### CRIMPIT™ STIRRUP

Hot-Line Clamp Adapter for Aluminum, ACSR, 6201, 5005, Compressed and Compact Conductors

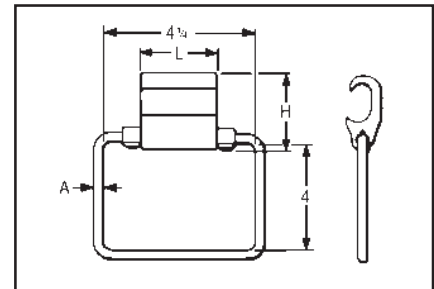

Combines Figure "6" -shaped aluminum CRIMPIT™ tap connector with tin-plated copper bail. Can be gripped in tool and

slipped over line for easy installation. Five sizes take range from #4 to 600 Mcm. Pre-filled with PENETROX™ joint compound and Stripsealed.

Catalog Number	Aluminum	ACSR, 6201, 5005	A	H	L	Die Index	Tools, Die Set Catalog Number, & (Number of Crimps)		
							Y35, Y750	Y45	Y46
YCB4U1	4 Sol. - 4 (7)	4	2 Sol.	1-1/2	1-7/8	D*	U-D (2)	†	‡
YCB1U1	2 (7) - 1 (7)	2		1-5/8					
YCB28U26	1/0 (7) - 4/0 (19)	1/0 - 4/0		2					
YCB33R26U	300 (37) - 400 (37)	266.8 (6-7) - 336.4 (30-7)		2-1/4	2-1/8	H	U-H (2)		
YCB38R26U	397.5 (19) - 600 (61)	336.4 (26-7) - 556.5 (18-1)	1/0 Sol.	R		U-R (2)			
						N	U-N (2)	S-N (2)	P-N (2)

\* Index number "D" is not "D3" Cabelok CRIMPIT™ die.  
 † U Die with adapter PT-6515  
 ‡ U Die with adapter PUADP-1.

H-36

## TYPES J990 & J1252

### HOT-LINE CLAMP BAILS

Designed to make hot-line clamp adapter using HYCRIMP™, CABELOK CRIMPIT™ or Figure "6" -Shaped CRIMPIT™ connectors. Where hot sticks are used, the CABELOK CRIMPIT™ or Figure "6" -shaped CRIMPIT™ are recommended. The line can be approached with the connector and bail held in the tool. Bails are tin-plated, hard drawn copper.

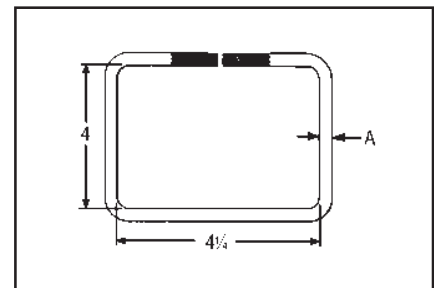

Recommended Connector & Bail Combinations						
HYCRIMP™ Cat. No.	CABELOK™ CRIMPIT™ Cat. No.	Bail	A	Run Conductors Accommodated*		
				Sol. Al	Str. Al	ACSR
YHO-100	YP2U3	J990	#2	6 - 2	6 - 3 (7 Str.)	6, 4
YHO-150	YP26AU2			1 - 2/0	3 (3 Str.) - 1/0	3 - 1/0
YHD-200	YP27AU4			3/0, 4/0	2/0 - 3/0	1/0, 2/0
YHD-250	YPC28U4			—	4/0	3/0, 4/0
YHD-300	YP27AU26	J1252	2/0	3/0	2/0, 3/0	2/0
YHD350	YP28U26			—	4/0	3/0, 4/0
—	YPC28U26	J990	#2	—	1/0 (7) - 4/0	1/0 - 4/0
		J1252	2/0			
		J990	#2			
YHN-500	YPC33R26U	J990	#2		250 (37)	266.8 (18-1)
		J1252	2/0		400 (37)	397.5 (18-1)

\* For additional run conductors see specific connector catalog page.

Blue highlighted items are industry standard and most frequently ordered.

**TYPES YHO-J, YHD-J, YHN-J**

**HYCRIMP™ STIRRUP**

Utilizing H-Framed Aluminum Tap Connectors with tin-plated copper bail. Bendable tabs secure run and bail freeing the lineman's hands to work with the installation tool conductor grooves. Prefilled with PENETROX™ joint compound.

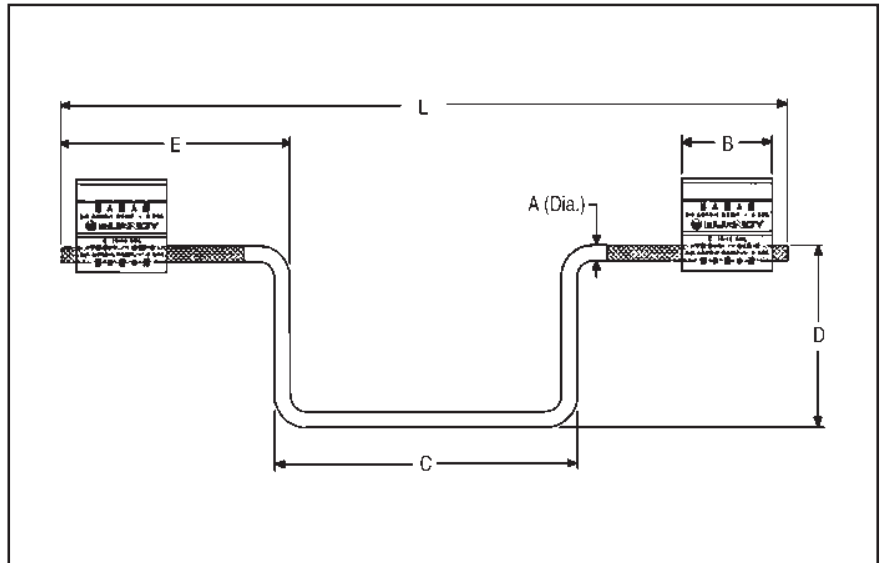

H-37

Catalog Number	Run Conductor Accommodates			A	B	C	D	E	L	Die Index	Tools, Die Set Catalog Number, & (Number of Crimps)	
	Sol. Al	Str. Al	ACSR								MD7-8 MD6-8 ①	Y35, Y750, Y45†, Y46‡
YHO100J1444	6 - 1	6 - 1 (7 Str.)	6 - 2	2 Sol. (.258 dia.)	1.50	5.00	3.00	3.75	12.0	0	(4)	U-0 (2)
YHO150J1444	1 - 2/0	3 - 2/0	3 - 1/0		1.75	5.00	3.00	3.75	12.0	0	(5)	U-0 (2)
YHD200J1444	3/0 - 4/0	2/0 - 3/0	1/0 - 2/0		1.88	5.00	3.00	3.75	12.0	D3	(5)	UD-3 (2)
YHD250J1444	250 - 300	4/0	3/0 - 4/0	2/0 Sol. (.365 dia.)	1.88	5.00	3.00	3.75	12.0	D3	(5)	UD-3 (2)
YHD300J1496	2/0 - 4/0	#1 (Str.) - 3/0	#1 - 2/0		1.88	5.00	4.75	5.62	15.5	D3	(5)	UD-3 (2)
YHD350J1496	250 - 300	3/0 - 4/0	3/0 - 4/0		2.50	5.00	4.75	5.62	15.5	D3	(7)	UD-3 (2)
YHN500J1496	—	4/0 - 500	4/0 - 477 (18/1)	2.00	5.00	4.75	5.62	15.5	N	—	U-N (2)	

① Permanent dies in tool install all sizes.  
 † U Die with adapter PT-6515  
 ‡ U Die with adapter PUADP-1.

Blue highlighted items are industry standard and most frequently ordered.

## TRANSFORMER AND EQUIPMENT TAP CONNECTORS

Transformer and equipment tap connectors are specifically designed to provide single or multi-tap connections from secondary transformer outlets, disconnects, circuit breaker panels, and other equipment pads or bar.

### TYPE E-C-G

H-38

#### TRANSFORMER TAP ADAPTER

For Copper

Multi-tap, range-taking cast copper alloy connector designed to take 2, 3, or 4 conductors from a single secondary transformer outlet.

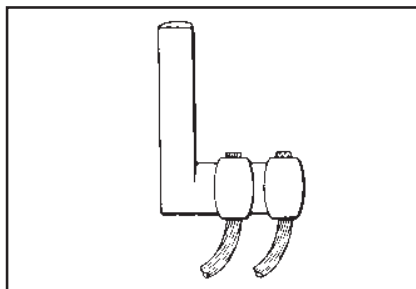
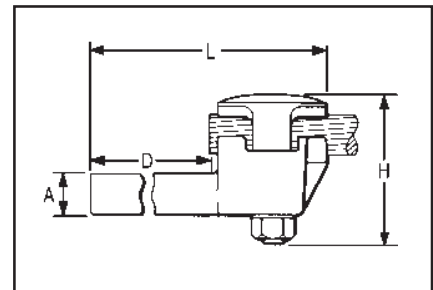
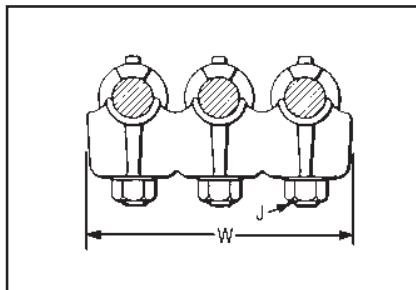

Catalog Number	Number of Conductors	Conductor Size	A Dia.	D	H	J	L	W
<b>E2C34G1</b>	2	1/0 Sol. - 500	.78	3-3/4	3-7/8	1/2-13	6-1/4	3-1/2
<b>E3C34G1</b>	3							5-1/4
<b>E4C34G1</b>	4							6-7/8

Blue highlighted items are industry standard and most frequently ordered.

**TYPE KC22J12T13,  
EQC632C**

**TRANSFORMER GROUND  
CONNECTORS**

For Copper

Fits all standard EEI-NEMA distribution transformers as a tank grounding terminal.



Catalog Number	Ranges
KC22J12T13	8 Sol. - 2 Sol.
KC26	2 Sol. - 2/0 Str.
KC34J12T13	3/0 - 500 Str.
EQC632C	8 Sol. - 2 Str.

Both, one-wrench installation.

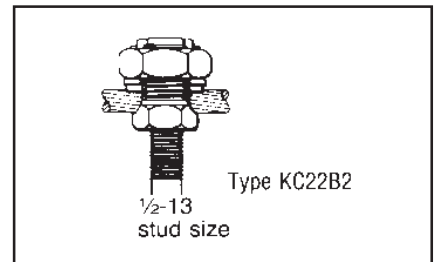

H-39

**TYPE YA-2LH**

**HYSEALUG™**

Terminal for Copper

Tin-plated, pure copper 2-hole NEMA compression terminal with shrouded barrel for terminating insulated copper conductor to transformers and other equipment. Shroud prevents seepage of water or moisture into conductor strands and minimizes taping.

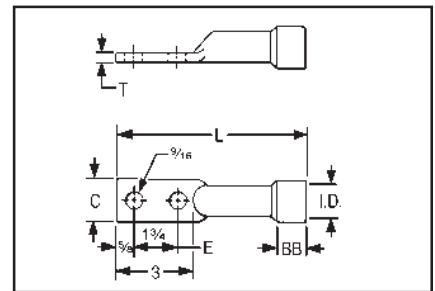

Catalog Number	Conductor	BB	Shroud Inside Diameter	C	L	T	Tools, Die Set Catalog Number, & (Number of Crimps)	
							MD7, MD6	Y35, Y750, Y45†, Y46‡
YAB4C-2LH72	4 Str.	5/8	.57	3/4	6-1/4	1/8	W161 (2)	U4CRT (2)
YAB2C-2LH74	2 Str.	3/4	.58		6-1/2		W162 (4)	U2CRT (2)
YAB2C2LH75			.91					
YAB25-2LH70	1/0 Str.	1	.69	7/8	6-3/4	3/8	W163 (4)	U25RT (2)
YAB25-2LH71			.98					
YA26-2LH89	2/0 Str.		1.04					6-1/4
YA28-2LH114	4/0 Str.		.86	1	6-5/8	1/8	W-BG or W243 (2)	U28RT (2)
YA28-2LH115			1.24					
YA29-2LH91			250				1.25	1-1/8
YA30-2LH85	300	1-1/4	.92	1-1/4	7		U30RT (2)	
YA31-2LH90	350		1.40	1-3/8	7-5/8	W-O (5)	U31RT (2)	
YA34-2LH110	500		1.14	1-1/2	7-3/4	1/4		U34RT (2)
YA34-2LH111		1.88						

† U Die with adapter PT-6515  
‡ U Die with adapter PUADP-1.

Blue highlighted items are industry standard and most frequently ordered.

**TYPE YE-LH**

**HYSEALPLUG™**

Terminal Plug for Copper

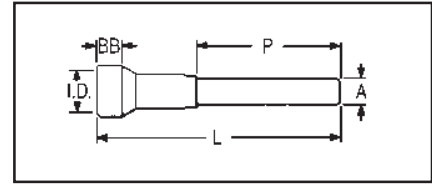
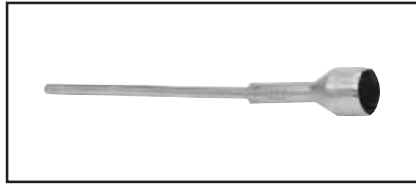

Oil and water-tight terminal with shrouded, tin-plated, copper barrel and brazed plug. Recommended for terminating insulated copper conductor at cutout, transformer and arrester; or for joining insulated copper riser to overhead conductor. Shroud prevents seepage of water or moisture into conductor strands and minimizes taping. To obtain a tight fit on some insulations in the shroud it may be necessary to either "pencil" the insulation down, or build it up with tape.

Catalog Number	Conductor	BB	Shroud Inside Dia.	A Dia.	L	P	Tools, Die Set Catalog Number, & (Number of Crimps)	
							MD7, MD6	Y35, Y750, Y45†, Y46‡
YE2C-LH128	2 Str.	3/4	.58	2 Sol.	9	6	W162 (4)	U2CRT (2)
YE2C-LH129			.91					
YE25-LH97	1/0 Str.	1	.98	1/0 Sol.	11-1/8	8	W163 (4)	U25RT (2)
YE26-LH88	2/0 Str.		.73	2/0 Sol.				
YE26-LH89			1.04					
YE28-LH128	4/0 Str.		1.24					
YE31-LH96	350	1-1/4	1.03	4/0 Sol.	11-1/2	8	W-BG or W243 (2)	U28RT (2)
YE34-LH119	500	1-1/2	1.14		12-1/4		W-0 (5)	U31RT (2)
YE34-LH120			1.88		13-1/4		—	U34RT (2)

† U Die with adapter PT-6515.  
‡ U Die with adapter PUADP-1.

H-40

**TYPES YE-R, YE-W**

**HYPLUG™**

Terminal Plug for Aluminum and ACSR

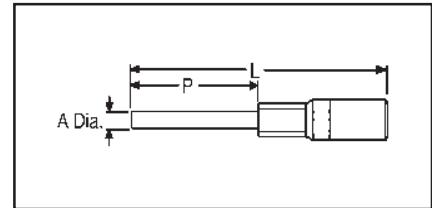
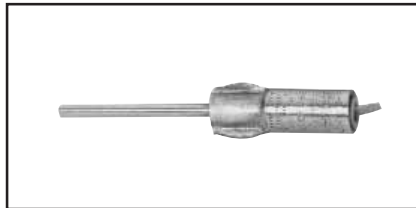

In 1989 BURNDY® began shipping an improved pin type connector. A proprietary coating system was developed through intense research efforts which vastly prolongs the life of this type of connection. To help identify the new product a hex shaped crimp is now used on the pin inter-

face crimp and BURNDY's overhead color coded end caps are utilized.

Aluminum HYPLUG™ with tin-plated copper plug for terminating aluminum or ACSR cable at cut-out, transformer and arrester. Plug

may be bent to desired angle for easier insertion. Three die sets accommodate 4 Str.-500 kcmil. Terminals are pre-filled with PENETROX™ A-13 joint compound and sealed with color coded end caps.

Catalog Number	Conductor		A Dia.	L	P	Color Code	Die Index	Tools, Die Set Catalog Number, & (Number of Crimps)*						
	Aluminum	ACSR						MD7, MD6	Y750, Y35, Y45†, Y46‡	Y48BH	Y60BH			
YE6R-25	5, 6 Str.	6	4 Sol.	4-5/8	2-1/2	Blue	BG or 243	BG WBG W243	U-BG	C243	L243			
YE4R-25	3, 4 Str.	4				Orange								
YE1WAG1	#1 Sol. (.289)	—				.257						8.58 (218)	6	Red
YE2WAG5	#2 Sol. (.258)	—				Orange								
YE2R-25	1, 2 Str.	2	2 Sol.	4-5/8	2-1/2	Red	5/8 - 1	UK5/8-1T						
YE25R-25	1/0 Str.	1/0	2 Sol.			Yellow								
YE26R-60	2/0 Str.	2/0	1/0 Sol.	9-1/2	6	Gray	249 or 840	W249 or W-K840	U249 U-K840T	C249	L249			
YE27R-60	3/0 Str.	3/0				Black								
YE28R-60	4/0 Str.	4/0				3/8						Pink		
YE30R-60	300	266.8 (26/7) (18/1)	4/0 Sol.	10-5/8	6	Blue	317, 705, 1-1/8 - 1	—	U317 U705 U-K1-18-1T	C317	L317			
YE32R-60	350 - 400	336.4 (26/7) (18/1)				Green								
YE361R-60	477, 500	477 (18/1)				9/16						Pink		
YE39R-60	600	556.5 (24/7) (26/7)				5/8						11-7/8	6	Yellow

\* All crimps overlap  
† U Die with adapter PT-6515.  
‡ U Die with adapter PUADP-1.

• BURNDY® furnishes many special versions of YE-R including: pin length variations, factory applied pin angles, etc. Contact your BURNDY® representative for your special needs.

Blue highlighted items are industry standard and most frequently ordered.



**COMPRESSION SPLICES**

**TABLE OF CONTENTS**

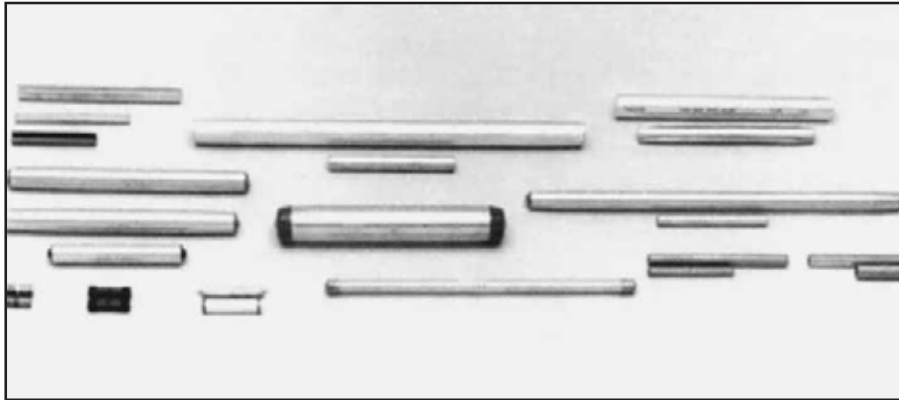

H-41

<b>COMPRESSION SPLICES</b> . . . . .	<b>H-42</b>	Types <b>YCU-R &amp; YOU-R</b> . . . . .	<b>H-52</b>
		Type <b>YCU-R</b> (Static Wire) . . . . .	<b>H-52</b>
<b>SERVICE ENTRANCE</b>		<b>FULL TENSION</b>	
Type <b>ES</b> . . . . .	<b>H-43</b>	Types <b>YDS-A &amp; YDS-AT</b> . . . . .	<b>H-53</b>
Type <b>YSU</b> . . . . .	<b>H-44</b>	Types <b>YDS &amp; YDS-C</b> . . . . .	<b>H-54</b>
Type <b>YSD</b> . . . . .	<b>H-45</b>	Types <b>YDS-W &amp; YDS</b> . . . . .	<b>H-55</b>
<b>NEUTRAL</b>		Types <b>YDS-R, YDS-RP1, YDS-RP2</b> . . . . .	<b>H-56, H-57</b>
Types <b>YSS, YCS-R, YDS-AT</b> . . . . .	<b>H-46</b>	Type <b>YDS-RLY</b> . . . . .	<b>H-58</b>
<b>JUMPER</b>		Types <b>YDS-RL &amp; YDS-LT</b> . . . . .	<b>H-59, H-60</b>
Type <b>YCS-R</b> . . . . .	<b>H-47</b>	Types <b>YDS-A &amp; YDS-AT</b> . . . . .	<b>H-60</b>
Type <b>YCS-RL</b> . . . . .	<b>H-48</b>	Types <b>YDS-R &amp; YDS-RE</b> . . . . .	<b>H-61</b>
Type <b>YCS-A</b> . . . . .	<b>H-49</b>	Types <b>YDS-E, YDS-H, YDS-U</b> . . . . .	<b>H-61</b>
Type <b>YCR</b> . . . . .	<b>H-49</b>	Type <b>YDS-K</b> . . . . .	<b>H-62</b>
Type <b>YCR-R-G</b> . . . . .	<b>H-50</b>	Type <b>YTS-E</b> . . . . .	<b>H-62</b>
Types <b>YDS, YCS</b> . . . . .	<b>H-51</b>	Types <b>YDS-KT &amp; YDS-F</b> . . . . .	<b>H-63</b>
<b>REPAIR SLEEVE</b>		Type <b>YDS-M-T</b> . . . . .	<b>H-63</b>
Type <b>YCU-A</b> . . . . .	<b>H-51</b>		
Type <b>YNU-R</b> . . . . .	<b>H-52</b>		

Blue highlighted items are industry standard and most frequently ordered.

## COMPRESSION SPLICES

BURNDY® service, full-tension, and jumper sleeves provide a dependable, economical, and easy-to-install method of splicing overhead transmission and distribution lines.

A major part of the Total Burndy Compression Program, they are available for copper, aluminum, ACSR, COPPERWELD, ALUMOWELD, Steel, 6201, 5005, ACSR/AW, AWA, and compressed forms for aluminum and ACSR. Each is clearly marked with the installation Die Index number and knurls are provided which show the installer the correct number of crimps and the spacing required. Connections made with BURNDY® INSULINK™ and HYSPLICE™ sleeves have a lower resistance than an equal length of conductor.

HYSPLICE™ sleeves are tapered or chamfered at the ends; externally to provide gradual reduction of pressure on the conductor, and internally to facilitate conductor insertion.

### Service Sleeve Design

Service entrance connectors are available insulated (INSULINK™) or uninsulated (LINKIT™). Both are installed with the one-hand OH25 and OUR840 HYTOOL™ or the MD6 HYTOOL™. The INSULINK™ feature polyethylene caps which seal out dirt and moisture, and grip the cable insulation leaving both hands free for crimping. The aluminum insert is anchored to the Nylon jacket so that it will not move when crimped, ensuring that the insert is always under the die. The jacket is color coded for easy identification of conductor size.

The aluminum LINKIT™ minimizes the effects of galvanic corrosion. It is designed for easy location of crimps, and is color coded.

The service HYSPLICE™ connectors are partial-tension sleeves for splicing the neutral conductor of triplex service. They are installed with MD6, OUR840 and the OH25 HYTOOL™ on aluminum and ACSR conductors from 6 to 1/0.

### Copper HYSPLICE™ Sleeve Design

Full-tension holding strength and high conductivity of BURNDY® copper HYSPLICE™ sleeves are accomplished through the combined action of correct contact length, proper number of circular crimps of precisely controlled depth that perform a current carrying and keying function between the conductor and the sleeve.

### Aluminum HYSPLICE™ Sleeve Design

HYSPLICE™ sleeves for aluminum conductor not only satisfy the basic tension requirements, but also deal with the problems of "cold flow" of aluminum and the oxide film which forms on the strands. "Cold flow" is compensated for by carefully coordinating the design of the sleeve and its associated installation die. To offset the effects of the non-conductive oxide film present on the surfaces of aluminum cable, BURNDY® HYSPLICE™ sleeves are pre-filled with PENETROX™ joint compound and capped or stripsealed. A solid center barrier forces the PENETROX™ around the cable strands during insertion.

### ACSR HYSPLICE™ Sleeve Design

#### Two-piece, Full-tension HYSPLICE™

Two-piece, full-tension HYSPLICE™ for ACSR consists of an inner steel sleeve for joining the steel core, and an outer aluminum sleeve for connecting the aluminum strands. To install the two-piece HYSPLICE™, the cable is cut, the aluminum sleeve slid onto the cable, aluminum strands cut back and

the steel sleeve installed. The aluminum sleeve is then centered over the steel sleeve, PENETROX™ joint compound injected (PENETROX™ is brushed on cable prior to centering aluminum sleeve on smaller sizes), and the sleeve is crimped.

### Single-sleeve, Full-tension UNISPLICE™

The UNISPLICE™ is as easy to install as aluminum full-tension sleeves. The single, heavy walled aluminum sleeve is filled with a special inhibiting compound containing grit particles which key the steel strand in place. The UNISPLICE™ eliminates cutting back of aluminum strands, the need for a separate steel sleeve, and careful positioning of the aluminum outer sleeve before crimping.

Since the standard pull-out tests are inadequate for evaluating UNISPLICE™ performance, BURNDY® has developed the sustained-tension test that subjects a connector-conductor assembly to a 168 hour sustained load equal to 90% of the conductor strength. This test simulates a service life of 30-40 years at 60% of the conductor strength.

### Jumper Sleeves

Since the holding strength required for jumper sleeves is less than that required for full-tension sleeves, the jumper HYSPLICE™ sleeve is shorter. Aluminum, ACSR, sleeves are pre-filled with PENETROX™ joint compound and installed with the same tools and dies as the full-tension sleeves.

Blue highlighted items are industry standard and most frequently ordered.

**TYPES ES**

**INSULINK™**

Service Entrance Sleeve for Insulated Combinations of Copper, Aluminum, ACSR Compressed

For use in overhead distribution applications.

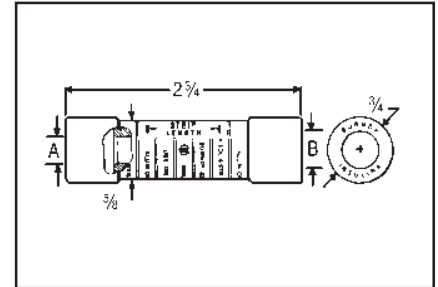

Pre-insulated service entrance compression connector installed with OH25, OUR840 and MD6 HYTOOL™ as well as Y35 and Y750 HYPRESS™ tools. Polyethylene caps prevent dirt from accumulating in barrel, grip cable for easy two-hand installation, and seal out moisture. Aluminum connector is

anchored to jacket, assuring the connector is under the die when crimping. Nylon jacket insulates connector electrically and protects against water and weather. Superior color coding. Pre-filled with PENETROX™ joint compound. Do not use insulated sealed connectors on bare conductors. Refer to LINKIT™ type connectors.

RUS Accepted

H-43

Catalog Number	Side A •			Side B •			Die Index	Tools, Die Set Catalog Number, & (Crimps per End)
	ACSR	Aluminum & Copper	Color Code	ACSR	Aluminum & Copper	Color Code		
ES8W8W	—	10 Str. 8 Sol.	Brown	—	10 Str. 8 Sol.	Brown	BG or 5/8	<b>HYTOOL™</b> <b>Tool Die (Crimps per End)</b> OH25 (1) MD6, MD7 (3) MD6, MD7 W-BG (1)* OUR840 X-NBG (1)*  <b>HYPRESS™</b> <b>Tool Die (Crimps per End)</b> Y35 U-BG (1)* Y750  *Multiple crimp die set, makes more than one crimp per tool compression. Figure indicates number of compressions.
ES6W8W	—	8 Str. 6 Sol.	Green	—	8 Str. 6 Sol.	Green		
ES6W6W	—	#8 AL Compt		—	#8 AL Compt	Green		
ES4W8W	6	5, 6 Str. 4 Sol.	Blue	—	10 Str. 8 Sol.	Brown		
ES4W6W				—	8 Str. 6 Sol.	Green		
ES4W4W				6	5, 6 Str. 4 Sol.	Blue		
ES2W8W	4	3, 4 Str. 2 Sol.	Orange	—	10 Str. 8 Sol.	Brown		
ES2W6W				—	8 Str. 6 Sol.	Green		
ES2W4W				6	5, 6 Str. 4 Sol.	Blue		
ES2W2W				4	3, 4 Str. 2 Sol.	Orange		
ES2R8W				—	10 Str. 8 Sol.	Brown		
ES2R6W	2	1 Str. 2 Str. #1 AL Compt #2 AL Compt	Red	—	8 Str. 6 Sol.	Green		
ES2R4W				6	5, 6 Str. 4 Sol.	Blue		
ES2R2W				4	3, 4 Str. 2 Sol.	Orange		
ES2R2R				2	1 Str. 2 Str. #1 AL Compt #2 AL Compt	Red		
ES25R6W	1/0, 1	1/0 Str. 1-19 Str.	Yellow	—	8 Str. 6 Sol.	Green		
ES25R4W				6	5, 6 Str. 4 Sol.	Blue		
ES25R2W				4	3, 4 Str. 2 Sol.	Orange		
ES25R2R				2	2 Str. 1 Str. #1 AL Compt #2 AL Compt	Red		
ES25R25R				1/0, 1	1/0 Str.	Yellow		
ES25A25A	—	1/0 Str. ▲	Yellow	—	1/0 Str.	Yellow		
ES25A4W	—			6	5, 6 Str., 4 Sol.	Blue		
ES25A2W	—			4	3, 4 Str., 2 Sol.	Orange		

^ Not for use on bare conductors.  
 ▲ Accommodates 1/0 stranded aluminum and copper, concentric, compressed and compact conductors.

Blue highlighted items are industry standard and most frequently ordered.

## TYPE YSU

### 5/8" LINKIT™

Service Entrance Sleeve for Combination of Copper, Aluminum and ACSR Compressed

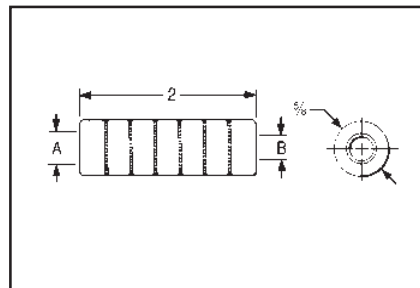

Heavy-walled aluminum tubing with solid barrier minimizes galvanic corrosion of conductors. Accommodates neutral strands of Type SE Service Entrance conductor as well as other conductors. Installed with standard tooling. Color Coded. Pre-filled with PENETROX™ joint compound and Stripsealed.

RUS Accepted

H-44

Catalog Number	Side A			Side B			Die Index	Tools, Die Set Catalog Number, & (Crimps per End)
	ACSR	Aluminum & Copper	Color Code	ACSR	Aluminum & Copper	Color Code		
YSU6W6W	—	8 Str. 6 Sol. #8 Al Compt	Green	—	8 Str. 6 Sol. #8 AL Compt	Green	BG or 5/8	<b>HYTOOL™</b> <b>Tool Die (Crimps per End)</b> OH25 (1) MD6, MD7 (3) MD6, MD7 W-BG (1)* OUR840 X-NBG (1)*  <b>HYPRESS™</b> <b>Tool Die (Crimps per End)</b> Y35 U-BG (1)* Y35L, Y750  *Multiple crimp die set, makes more than one crimp per tool compression. Figure indicates number of compressions.
YSU4W8W	6	5, 6 Str. 4 Sol. #4 Al Compt	Blue	—	8 Sol. 10 Str.	Brown		
YSU4W6W				—	6 Sol. 8 Str. #8 AL Compt	Green		
YSU4W4W				6	5, 6 Str. 4 Sol. #4 AL Compt	Blue		
YSU2W8W	4	3, 4 Str. 2 Sol.	Orange	—	8 Sol. 10 Str.	Brown		
YSU2W6W				—	6 Sol. 8 Str. #8 AL Compt	Green		
YSU2W4W				6	5, 6 Str. 4 Sol. #4 AL Compt	Blue		
YSU2W2W				4	3, 4 Str. 2 Sol.	Orange		
YSU2R8W	2	2 Str. 1 Str. #1 Al Compt #2 Al Compt	Red	—	8 Sol. 10 Str.	Brown		
YSU2R6W				—	6 Sol. 8 Str. #8 AL Compt	Green		
YSU2R4W				6	5, 6 Str. 4 Sol. #4 AL Compt	Blue		
YSU2R2W				4	3, 4 Str. 2 Sol.	Orange		
YSU2R2R				2	2 Str. 1 Str. #1 AL Compt #2 AL Compt	Red		
YSU25R6W	1/0	1/0 Str. 2/0 Al Compt 1/0 Al Compt	Yellow	—	8 Str. 6 Sol. #8 AL Compt	Green		
YSU25R4W				6	5, 6 Str. 4 Sol. #4 AL Compt	Blue		
YSU25R2W				4	3, 4 Str. 2 Sol.	Orange		
YSU25R2R				2	2 Str. 1 Str. #1 AL Compt #2 AL Compt	Red		
YSU25R25R				1/0	1/0 Str. 2/0 AL Compt 1/0 AL Compt	Yellow		
YSU25A25A	1-1	1/0 Str. ▲	Yellow	1/0	1/0 Str.	Yellow		

▲ Accommodates 1/0 standard aluminum and copper concentric, compressed and compact conductors.

Blue highlighted items are industry standard and most frequently ordered.

**TYPE YSD**

**.840" LINKIT™**

Service Entrance Sleeve for Combinations of Copper, Aluminum, ACSR, 6201, 5005 and Compressed

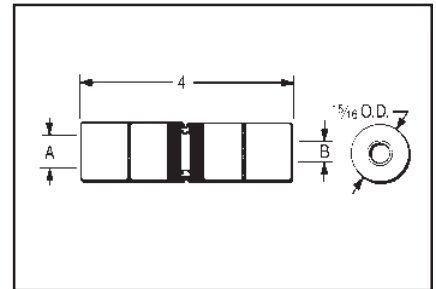

Aluminum compression sleeve with solid center barrier. Designed for commercial and heavy residential services. Installed with standard tooling. Pre-filled with PENETROX™ joint compound, and capped.

RUS Accepted

Catalog Number	Side A			Side B			Die Index	Tools, Die Set Catalog Number, & (Crimps per End)																							
	ACSR, 6201, 5005	Aluminum & Copper	Color Code	ACSR, 6201, 5005	Aluminum & Copper	Color Code																									
YSD25R25R	1/0	1/0 Str. 2/0 AL Compt	Yellow	1/0	1/0 2/0 AL Compt	Yellow	EEL IIA 249 840	<p><b>HYTOOL™</b></p> <table border="1"> <thead> <tr> <th>Tool</th> <th>Die</th> <th>(Crimps per End)</th> </tr> </thead> <tbody> <tr> <td>MD6,</td> <td>WK-840</td> <td>(7)</td> </tr> <tr> <td>MD7</td> <td>W-249</td> <td>(4)</td> </tr> <tr> <td rowspan="2">OUR840</td> <td>X840</td> <td>(7)</td> </tr> <tr> <td>X249</td> <td>(8)</td> </tr> </tbody> </table> <p><b>HYPRESS™</b></p> <table border="1"> <thead> <tr> <th>Tool</th> <th>Die</th> <th>(Crimps per End)</th> </tr> </thead> <tbody> <tr> <td>Y35</td> <td>UK840</td> <td>(4)</td> </tr> <tr> <td>Y750*</td> <td>U249</td> <td>(2)</td> </tr> </tbody> </table> <p>*Multiple crimp die set, makes more than one crimp per tool compression. Figure indicates number of compressions.</p>	Tool	Die	(Crimps per End)	MD6,	WK-840	(7)	MD7	W-249	(4)	OUR840	X840	(7)	X249	(8)	Tool	Die	(Crimps per End)	Y35	UK840	(4)	Y750*	U249	(2)
Tool	Die	(Crimps per End)																													
MD6,	WK-840	(7)																													
MD7	W-249	(4)																													
OUR840	X840	(7)																													
	X249	(8)																													
Tool	Die	(Crimps per End)																													
Y35	UK840	(4)																													
Y750*	U249	(2)																													
YSD26R2W	2/0	2/0 Str. 3/0 AL Compt	Gray	4	3, 4 Str. 2 Sol. #2 AL Compt	Orange																									
YSD26R2R				2	2 Str. 1 Str. 1/0 AL Compt	Red																									
YSD26R25R				1/0	1/0 Str. 2/0 AL Compt	Yellow																									
YSD26R26R				2/0	2/0 Str. 3/0 AL Compt	Gray																									
YSD27R2W				3/0	3/0 Str. 4/0 AL Compt	Black			4	3, 4 Str. 2 Sol. #2 AL Compt	Orange																				
YSD27R2R	2	2 Str. 1 Str. 1/0 AL Compt	Red																												
YSD27R25R	1/0	1/0 Str. 2/0 AL Compt	Yellow																												
YSD27R26R	2/0	2/0 Str. 3/0 AL Compt	Gray																												
YSD27R27R	3/0	3/0 Str. 4/0 AL Compt	Black																												
YSD28R2W	4/0	4/0 Str. 300 AL Compt	Pink	4	3, 4 Str. 2 Sol. #2 AL Compt	Orange																									
YSD28R2R				2	2 Str. 1 Str. 1/0 AL Compt	Red																									
YSD28R25R				1/0	1/0 Str. 2/0 AL Compt	Yellow																									
YSD28R26R				2/0	2/0 Str. 3/0 AL Compt	Gray																									
YSD28R27R				3/0	3/0 Str. 4/0 AL Compt	Black																									
YSD28R28R				4/0	4/0 Str. 300 AL Compt	Pink																									

H-45

Blue highlighted items are industry standard and most frequently ordered.

## TYPES YSS, YCS-R & YDS-AT

### HYSPLICE™

For Aluminum, ACSR, 6201, 5005 and Compressed



Single aluminum sleeve designed for service drop or short span overhead distribution lines. Installed with OH25 one-hand tool, and other standard tooling. Pre-filled with PENETROX™ joint compound and color coded capped.

H-46

Catalog Number	Conductor	L	Holding Strength Lbs.	Die Index	Color Code	Tools, Die Sets Catalog Number, & (Crimps per End)		OH25 Applications	
						MD7, MD6	Y35, Y750, Y45†, Y46‡	Conductor	OH25 (Indents per End)
<b>YSS6RG2</b>	6 ACSR	4.00	900 700	BG or 5/8	Blue	BG (6) W-BG (3)*	U-BG (3)*	—	—
<b>YSS6R</b>	4 Sol. Al	4.72	900 700	162	Blue	W162 (4)	U162 (2)*	—	—
<b>YDS4WA</b> <b>YDS4CA</b>	4 Sol. Al 4 Str. Al (7)	2.62	750** 700**	162	Orange	W162 (4)	U162 (1)*	—	—
<b>YSS4R</b>	4 ACSR	3.78	1000	BG or 5/8	Orange	BG (6) W-BG (3)*	U-BG (3)*	4 7 Al	(3)
	2 Sol. Al		800					4 5005 Al	(2)
	4 Al (7)		700					4 5005 Al	(3)
<b>YSS2R</b>	2 ACSR	3.78	1600	BG or 5/8	Red	BG (6) W-BG (3)*	U-BG (3)*	4 (6-1) ACSR	(3)
	2 Al (7)		1200					4 (6-1) ACSR	(2)
<b>YDS25AT</b>	1/0 Al (7)	7.27	2000	BG, 5/8 or 243	Yellow	BG (12) W-BG (6)*	U-BG (6)*	4 (7-1) ACSR	(3)
<b>YCS25R</b>	1/0 ACSR	7.09	2320					2 Sol. Al	(3)
								2 Sol. Al	(2)
								2 (6-1) ACSR	(3)
								2 (7-1) ACSR	(3)
								2 (7-1) ACSR	(2)
								2 7 Al	(3)
								1/0 7 Al	(4)
								1/0 (6-1) ACSR	(2)
								1/0 (6-1) ACSR	(3)

\* Multiple crimp die set; makes more than one crimp per tool compression. Figure indicates number of compressions.

\*\* Holding strength values up to 800 lbs. are obtained when HYPRESS™ tools are used for installations.

† U Die with adapter PT-6515

‡ U Die with adapter PUADP-1.

Blue highlighted items are industry standard and most frequently ordered.

**TYPE YCS-R**

**HYSPLICE™**

Jumper Sleeve for ACSR,  
All Aluminum, 6201, 5005 and  
Compressed



RUS Accepted

HYSPLICE™ sleeve designed to withstand jumper loop tensile and vibration stresses. Made of aluminum with staked-in cable stop. Installed with same die as equivalent full-tension sleeves. Pre-filled with PENETROX™ joint compound.

Catalog Number	Conductor		L	Die Index	Tools, Die Set Catalog Number, & (Crimps per End)					
	ACSR, 6201, 5005	All Aluminum			MD7, MD6	Y35, Y750	Y45	Y46	Y48B	Y60BHU
<b>YCS4R</b>	4	4 (7)	5	237	W237 (4)	U237 (2)	†	‡	—	—
<b>YCS2R</b>	2	2 (7)	5	239	W239 (4)	U239 (2)	†	‡	—	—
<b>YCS25R</b>	1/0	1/0 (7, 19)	7-1/8	243	WBG (10) or W243 (6)	UBG (6) or U243 (3)	†	‡	—	—
<b>YCS26R</b>	2/0	2/0 (7, 19)	7	245	W245 (6)	U245 (3)	†	‡	—	—
<b>YCS27R</b>	3/0 110.8 (12-7)	3/0 (7, 19)	5-3/4	247	W247 (6)	U247 (3)	†	‡	—	—
<b>YCS28R</b>	4/0	4/0 (7, 19)	5-3/4	249	W249 (6)	U249 (3)	†	‡	C249 (2)	L249 (2)
<b>YCS30R</b>	266.8 (6/7, 18/1, 26/7)	266.8	6.47	251	W251 (10)	U251 (6)	†	‡	C251 (3)	L251 (3)
<b>YCS321R</b>	336.4 (18-1) 300	336.4 (19)	6-1/2	490	—	U490 (5)	†	‡	C490 (3)	L490 (3)
<b>YCS33R</b>	336.4 (26-7, 30-7)	397.5 (19)	8-3/4	316	—	U316 (6)	†	‡	C316 (2)	L316 (2)
<b>YCS35R</b>	397.5 (18-1, 26-7, 30-7)	477 (19, 37) 500 (37, 61)	8-7/8	317	—	U317 (6)	†	‡	C317 (2)	L317 (2)
<b>YCS361R</b>	477 (18-1)	500 (37, 61)	8-1/4	327	—	U327 (6)	†	‡	C327 (2)	L327 (2)
<b>YCS37R</b>	477 (24-7, 26-7, 30-7) 556.5 (18-1)	556.5 (19, 37)	8-3/4	261	—	U261 (6)	†	‡	C261 (2)	L261 (2)
<b>YCS39R</b>	556.5 (24-7, 26-7)	—	10-3/4	608	—	U608 (9)	†	‡	C608 (3)	L608 (3)
<b>YCS43R</b>	605 (30-19) 636 (24-7, 26-7, 30-19) 666.6 (24-7, 54-7)	795 (37)	10-5/8	292 or 319	—	—	S292 (9) S319 (9)	P292 (9) P319 (9)	C292 (3) C319 (3)	L292 (3) L319 (3)
<b>YCD453R</b>	795 (36-1, 45-7)	—	10-5/8	292	—	—	S292 (9)	P292 (9)	C292 (3)	L292 (3)
<b>YCS45R</b>	795 (26-7, 54-7)	900 (61, 91)	10-5/8	352	—	—	S352 (9)	P352 (9)	C352 (3)	L352 (3)

† U Die with adapter PT-6515  
‡ U Die with adapter PUADP-1.

H-47

Blue highlighted items are industry standard and most frequently ordered.

## TYPE YCS-RL

### UNISPLICE™

Jumper Sleeve for ACSR, All Aluminum 6201, 5005 Compressed and Compact Conductors

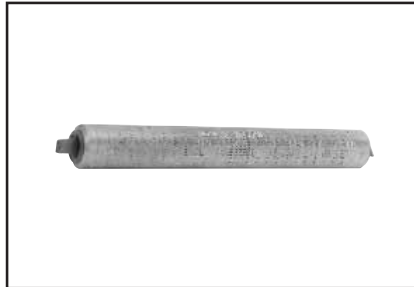

Aluminum jumper sleeve, with cable stop, designed to be installed with same dies as equivalent full-tension UNISPLICE™. Withstands jumper loop-tensile and vibration stresses. Pre-filled with PENETROX™ joint compound and capped.

H-48

Catalog Number	Conductor †††	L	Die Index	Tools, Die Set Catalog Number, & (Crimps per End)	
				MD7, MD6	Y35, Y750, Y45†, Y46‡
YCS25RL	1/0 ACSR (6-1)	6-1/4	C or 247 or 702	W-C (12)	—
	1/0 6201 (7)			—	U247 (3)
	1/0 5005 (7)			W702 (4)	—
	1/0 AAC (7)			NON-BOW*	
YCS26RL	2/0 ACSR (6-1)	5-5/8	659	—	U659 (3)
	2/0 6201 (7)				
	2/0 5005 (7)				
	2/0 AAC (7)				
YCS28RL	4/0 ACSR (6-1)	5-1/4	654	—	U654 (3)
	4/0 6201 (7)				
	4/0 5005 (7)				
	4/0 AAC (7)				
YCS321RL	336.4 ACSR (18-1)	5-1/4	655	—	U655 (3)
	336.4 AAC (19)				
YCS341RL	397.5 AAC (19)	5-5/8	327	—	U327 (4)
	397.5 ACSR (18-1)				
	400 AAC (37, 61)				
	336.4 ACSR (18-1)				
	336.4 ACSR (26-7)				

\* MD6 NON-BOW Dies produce straight sleeves without rotating tool.

† U Die with adapter PT-6515

‡ U Die with adapter PUADP-1.

††† Accommodates ACSR with aluminized steel core.

Blue highlighted items are industry standard and most frequently ordered.



## TYPE YCS-A

### JUMPER SLEEVE

For All Aluminum, Compressed and Compact Conductors



HYSPLICE™ sleeve designed to withstand jumper loop tensile and vibration stresses. Made of aluminum with staked-in cable stop. Installed with same die as equivalent full-tension sleeve. Pre-filled with PENETROX™ joint compound and capped.

Catalog Number	Conductor	L	Die Index	Tools, Die Set Catalog Number, & (Crimps per End)					
				MD7, MD6	Y35, Y750	Y45	Y46	Y48B	Y60BHU
YCS26A	2/0 (7)	5-1/8	245	W245 (4)	U245 (2)	†	‡	—	—
YCS28A	4/0 (7, 19)	4	249	W249 (4)	U249 (2)	†	‡	C249 (1)	L249 (1)
YCS301A	336.4 (19, 37)	4-3/8	321	—	U321 (3)	†	‡	C321 (2)	L321 (2)
YCS311A	397.5 (19)	5-5/8	468	—	U468 (4)	†	‡	—	—
YCS331A	477 (19, 37, 61)	6-14	317	—	U317 (6)	†	‡	C317 (2)	L317 (2)
YCS331A	500 (19, 37, 61)	6-1/4	317	—	U317 (6)	†	‡	C317 (2)	L317 (2)
YCS351A	556.5 (19, 37)	8-3/4	261	—	U261 (6)	†	‡	C261 (2)	L261 (2)
YCS361A	636 (37)	7-3/8	469	—	—	S469 (6)	P469 (6)	C469 (2)	L469 (2)
YCS391A	795 (37, 61)	10-1/2	342	—	—	S342 (9)	P342 (9)	C342 (3)	L342 (3)

† U Die with adapter PT-6515  
 ‡ U Die with adapter PUADP-1.

H-49

## TYPE YCR

### JUMPER SLEEVE REDUCER

For Copper Conductors

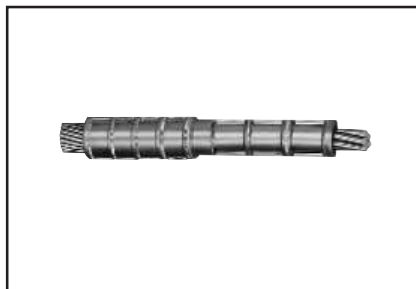

Copper sleeve designed to join different size copper conductors on transmission jumper applications. Installed with same dies as full-tension sleeves.

Catalog Number	Copper Conductor		L	Die Index	Tools, Die Set Catalog Number, & (Crimps per End)				Tools, Die Set Catalog Number, & (Crimps per End)				
					Side A				Die Index	Side B			
	Side A	Side B			MD7, MD6	Y35, Y750, Y45†, Y46‡	Y48B	Y60BHU		MD6	Y35, Y750, Y45†, Y46‡	Y48B	Y60BHU
YCR2625	2/0 (7, 12, 19)	1/0 (7, 19)	3-3/8	166	W166 (6)	U166/U459	C166 (1)	L166 (1)	165	W165 (3)	U165/U205	C165 (1)	L165 (1)
YCR2725	3/0 (7, 19)	1/0 (7, 19)	3-1/2	167	—	U167/U568	C167 (1)	L167 (1)	165	W165 (3)	U165/U205	C165 (1)	L165 (1)
YCR2825	4/0 (7, 12, 19)	1/0 (7, 19)	3-3/8	168	—	U168 (3)	C168 (1)	L168 (1)	165	W165 (3)	U165/205	C165 (1)	L165 (1)

\* Multiple crimp die set; makes more than one crimp per tool compression. Figure indicates number of compressions.  
 † U Die with adapter PT-6515.  
 ‡ U Die with adapter PUADP-1.

Blue highlighted items are industry standard and most frequently ordered.

**TYPE YCR-R-G**

**HYSPLICE™**

Jumper Sleeve Reducer for ACSR, AAAC and Aluminum to Copper

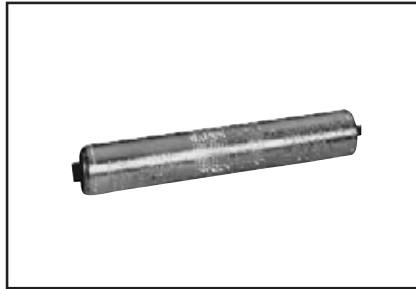

Heavy-walled aluminum sleeve designed to connect all aluminum or ACSR to copper conductors, in all service conditions encountered in transmission and distribution. Sleeve has solid center barrier and is pre-filled with PENETROX™ joint compound and capped.

H-50

Catalog Number	Side A		Side B		L	O.D.	Tools, Die Set Catalog Number, & (Crimps per End)		
	ACSR, 6201, 5005	Aluminum, Copper	ACSR, 6201, 5005	Aluminum, Copper			Die Index	Y35, Y750, Y45†, Y46‡	Y60B
YCR25RG6	1/0 (6-1)	1/0 (7, 12, 19)	1/0 (6-1)	1/0 (7, 12, 19)	6-3/8	1-1/16	654 or 705	U654 U705  Crimps Overlap	L654 —  Crimps Overlap
YCR26RG2	2/0 (6-1)	2/0 (7, 12, 19)	1/0 (6-1)	1/0 (7, 12, 19)					
YCR26RG3			2/0 (6-1)	2/0 (7, 12, 19)					
YCR27RG5	3/0 (6-1)	3/0 (7, 12, 19)	1/0 (6-1)	1/0 (7, 12, 19)					
YCR27RG6			2/0 (6-1)	2/0 (7, 12, 19)					
YCR28RG5	4/0 (6-1)	4/0 (7, 12, 19)	1/0 (6-1)	1/0 (7, 12, 19)					
YCR28RG6			2/0 (6-1)	2/0 (7, 12, 19)					
YCR28RG7			3/0 (6-1)	3/0 (7, 12, 19)					
YCR28RG8			4/0 (6-1)	4/0 (7, 12, 19)					
YCR291RG2	266.8 (18-1)	250 (19, 37) 266.8 (7, 12, 19)	2/0 (6-10)	2/0 (7, 12, 19)	7-3/8	1-1/4	317 or 705	U317 U705 Crimps Overlap	L317 — Crimps Overlap
YCR291RG3			3/0 (6-1)	3/0 (7, 12, 19)					
YCR291RG4			4/0 (6-1)	4/0 (7, 12, 19)					
YCR291RG5	266.8 (18-1)	250 (19, 37) 266.8 (7, 12, 19)							
YCR30RG4	266.8 (26-7)	300 (19, 37) 336.4 (19)	1/0 (6-1)	1/0 (7, 12, 19)					
YCR30RG6			3/0 (6-1)	3/0 (7, 12, 19)					
YCR30RG7			4/0 (6-1)	4/0 (7, 12, 19)					
YCR32RG1	336.4 (18-1) (26-7)	350 (19, 37) 397.5 (19)	1/0 (6-1)	1/0 (7, 12, 19)	7-3/8	1-1/4	317 or 705	U317 U705 Crimps Overlap	L317 — Crimps Overlap
YCR32RG2			2/0 (6-1)	2/0 (7, 12, 19)					
YCR32RG3			3/0 (6-1)	3/0 (7, 12, 19)					
YCR32RG4			4/0 (6-1)	4/0 (7, 12, 19)					
YCR32RG5			266.8 (18-1)	250 (19, 37) 266.8 (7, 12, 19)	6-5/8	1-1/4	317 or 705	U317 U705 Crimps Overlap	L317 — Crimps Overlap
YCR32RG6			266.8 (26-7)	300 (19, 37) 336.4 (19)					
YCR32RG7			336.4 (18-1) (26-7)	350 (19, 37) 397.5 (19)					

\* Crimps overlap on both ends.  
 † U Die with adapter PT-6515  
 ‡ U Die with adapter PUADP-1.

Blue highlighted items are industry standard and most frequently ordered.

## TYPES YDS & YCS

### HYSPLICE™

Jumper Sleeve for Copper Conductors



Loop HYSPLICE™ connector designed to withstand jumper loop tensile and vibration stresses. Made of pure copper tubing. Installed with standard HYSPLICE™ tools and dies.

RUS Accepted

Catalog Number	Conductor	L	Die Index	Tools, Die Set Catalog Number, & (Crimps per End)			
				MD7, MD6	Y750, Y35, Y45†, Y46‡	Y48B	Y60BHU
YDS8W	8 Sol.	1-5/8	171	W171 (1)	U171 (1)*	—	—
YDS6W	6 Sol.	2-5/8	161	W161 (2)	U161 (1)*	—	—
YDS4W	4 Sol.	2-1/2	162	W162 (4)	U162 (1)*	—	—
YDS2W	2 Sol.	3-3/4	163	W163 (6)	U163 (2)*	—	—
YDS6C	6 (7)	2-3/4	161	W161 (2)	U161 (1)*	—	—
YDS4C	4 (7)	2-5/8	162	W162 (4)	U162 (1)*	—	—
YDS2C	2 (7), 3 (3)	3-5/8	163	W163 (6)	U163 (2)*	—	—
YDS1C	1 (7, 19)	3-1/8	164	W164 (4)	U164 (2)*	—	—
YCS25	1/0 (7, 19)		165	W165 (3)	U165 (3)	—	—
YCS26	2/0 (7, 11, 12, 19)	3-3/8	166	W166 (6)	U166 (3)	—	—
YCS27	3/0 (7, 19)	3-1/4	167	—	U167 (3)	—	—
YCS28	4/0 (7, 12, 19)	3-1/8	168	—	U168 (3)	C168 (1)	L168 (1)
YCS29	250 (7, 19, 37)	3-5/8	169	—	U169 (4)	C169 (2)	L169 (2)
YCS30	300 (19, 37)		170	—	U170 (4)	C170 (1)	L170 (1)
YCS31	350 (12, 19, 37)	5-3/8	267	—	U267 (6)	C267 (2)	L267 (2)
YCS32	400 (19, 37)	5-3/4	209	—	U209 (6)	C209 (2)	L209 (2)
YCS34	500 (19, 37)	5-1/8	210	—	U210 (6)	C210 (2)	L210 (2)
YCS39	750 (37)	6-7/8	627	—	—	C627 (3)	L627 (3)
YCS44	1000 (37, 61)	7-3/4	345	—	—	C345 (4)	L345 (4)

\* Multiple crimp die set; makes more than one crimp per tool compression. Figure indicates number of compressions.

† U Die with adapter PT-6515

‡ U Die with adapter PUADP-1.

H-51

## TYPE YCU-A

Repair Sleeve for All Aluminum, Compressed and Compact Conductors

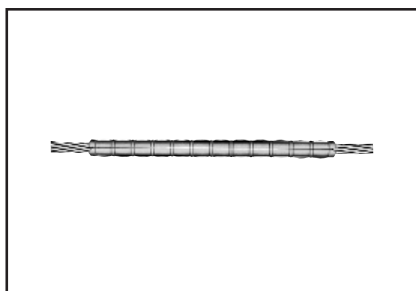

For restoring conductivity to damaged conductors. Made of cast aluminum. Use same die as equivalent full-tension sleeve. Use of PENETROX™ joint compound required.

Catalog Number	Conductor	L	Die Index	Tools, Die Set Catalog Number, & (Number of Crimps)					
				MD7, MD6	Y35, Y750	Y45	Y46	Y48B	Y60BHU
YCU2CA	2 (7)	7-5/8	163	W163 (27)	U163 (9)*	†	‡	—	—
YCU25A	1/0 (7)	8-3/4	243	W243 (20)	U243 (10)	†	‡	—	—
YCU28A	4/0 (7, 19)	11-7/8	249	W249 (28)	U249 (14)	†	‡	C249 (7)	L249 (7)
YCU291A	266.8 (7)	11-5/8	251	—	U251 (20)	†	‡	C251 (10)	L251 (10)
YCU301A	336.4 (19, 37)	11-5/8	321	—	U321 (20)	†	‡	C321 (10)	L321 (10)

\* Multiple crimp die set; makes more than one crimp per tool compression. Figure indicates number of compressions.

† U Die with adapter PT-6515.

‡ U Die with adapter PUADP-1.

Blue highlighted items are industry standard and most frequently ordered.

## TYPES YCU-R & YOU-R

Repair Sleeve for ACSR and Compressed and Compact Conductors



For restoring conductivity to damaged conductors. Made of cast aluminum. Sizes up thru 266.8 are U-shaped. For 300 and larger, sleeves are two-piece interlocking elements. Use same die as equivalent full-tension sleeve. Use of PENETROX™ joint compound required.

H-52

Catalog Number	Conductor	L	Die Index	Tools, Die Set Catalog Number, & (Number of Crimps)					
				MD7, MD6	Y35, Y750	Y45	Y46	Y48B	Y60BHU
YCU4R	4 (6-1, 7-1) 4AAC	6-1/4	237	W237 (12)	U237 (6)	†	‡	—	—
YCU4RG1	4 (7-1)	8-1/4	239	W239 (16)	U239 (8)	†	‡	—	—
YCU2R	2 (6-1, 7-1)					†	‡	—	—
YCU25R	1/0 (6-1)	8-3/4	243	W243 (20)	U243 (10)	†	‡	—	—
YCU26R	2/0 (6-1)	10	245	W245 (24)	U245 (12)	†	‡	—	—
YCU27R	3/0 (6-1)		247	W247 (24)	U247 (12)	†	‡	—	—
YCU28R	4/0 (6-1)	11-7/8	249	W249 (28)	U249 (14)	†	‡	C249 (7)	L249 (7)
YCU30R	266.8 (6-7, 18-1, 26-7)	11-5/8	251	—	U251 (20)	†	‡	C251 (10)	L251 (10)
YOU32R	300 (26-7)	13	316	—	U316 (21)	†	‡	C316 (7)	L316 (7)
YCU321R	336.4 (18-1)	11-5/8	490, 547	—	U490 (20)	†	‡	C490 (10)	L490 (10)
YOU33R	336.4 (26-7, 30-7)	13	316	—	U316 (21)	†	‡	C316 (7)	L316 (7)
YOU35R	397.5 (18-1, 26-7, 30-7)		317, 426	—	U317 (21)	†	‡	C317 (7)	L317 (7)
YOU361R	477 (18-1)		327	—	U327 (21)	†	‡	C327 (7)	L327 (7)
YOU37R	477 (24-7, 26-7, 30-7)		261, 318	—	U261 (21)	†	‡	C261 (7)	L261 (7)
YOU39R	556.5 (24-7, 26-7)	13-3/4	608	—	U608 (24)	†	‡	C608 (8)	L608 (8)
YOU41R	605 (24-7, 54-7)		292, 578	—	—	S292 (24)	P292 (24)	C292 (8)	L292 (8)
YOU43R	605 (30-19)		—	—	—	—	—	C352 (8)	—
YOU43R	605 (30-19)		319	—	—	S319 (24)	P319 (24)	C319 (8)	L319 (8)
YOU421R	636 (36-1)		292, 578	—	—	S292 (24)	P292 (24)	C292 (8)	L292 (8)
YOU43R	636 (26-7, 30-19)		—	—	—	—	—	—	—
YOU43R	666.6 (24-7, 54-7)		319	—	—	S319 (24)	P319 (24)	C319 (8)	L319 (8)
YOU453R	715.5 (26-7)		292, 578	—	—	S292 (24)	P292 (24)	C292 (8)	L292 (8)
YOU453R	795 (36-1)		319	—	—	S319 (24)	P319 (24)	C319 (8)	L319 (8)
YOU453R	795 (36-1)		292, 578	—	—	S292 (24)	P292 (24)	C292 (8)	L292 (8)
YOU44R	715.5 (54-7)		—	—	—	—	—	—	—
YOU44R	715.5 (54-7)		319	—	—	S319 (24)	P319 (24)	C319 (8)	L319 (8)
YOU45R	795 (26-7, 54-7)		352, 579	—	—	S352 (24)	P352 (24)	C352 (8)	L352 (8)
YOU45R	795 (26-7, 54-7)		—	—	—	S579 (24)	P579 (24)	C579 (8)	L579 (8)
YOU48R	900 (54-7) 954 (54-7)	14-1/4	575	—	—	—	—	C575 (10)	L575 (10)
YOU49R	1033.5 (54-7)		422	—	—	—	—	—	L422 (10)

† U Die with adapter PT-6515.

‡ U Die with adapter PUADP-1.

## TYPE YCU-R

Repair Sleeve for ACSR “Static Wire”

Catalog Number	Conductor	L	Die Index	Tools, Die Set Catalog Number, & (Number of Crimps)			
				MD7, MD6	Y35, Y750, Y45†, Y46‡	Y48B	Y60BHU
YCU27R	110.8 (12-7)	10	247	W247 (24)	U247 (12)	—	—
YCU28R	159 (12-7)	11-7/8	249	W249 (28)	U249 (14)	C249 (7)	L249 (7)
YCU30R	190.8 (12-7)	11-5/8	251	—	U251 (20)	C251 (10)	L251 (10)

† U Die with adapter PT-6515.

‡ U Die with adapter PUADP-1.

Blue highlighted items are industry standard and most frequently ordered.

**TYPES YDS-A  
& YDS-AT**

**HYSPLICE™**

Full Tension Sleeve for All Aluminum Compressed and Compact Conductors



Full-Tension HYSPLICE™ sleeve made of aluminum tubing with staked-in cable stop. Sizes 1/0 and larger tapered for gradual transition of stress. Installed with HYSPLICE™ tools and dies. Pre-filled with PENETROX™ joint compound and capped.

Catalog Number	Conductor	L	Die Index	Tools, Die Set Catalog Number, & (Number of Crimps)					
				MD7, MD6	Y35, Y750	Y45	Y46	Y48B	Y60BHU
YDS6WA	6 Sol.	3	161	W161 (2)	U161 (1)*	†	‡	—	—
YDS4WA	4 Sol.	2-5/8	162	W162 (4)	U162 (1)*	†	‡	—	—
YDS2WA	2 Sol.	3-7/8	163	W163 (6)	U163 (2)*	†	‡	—	—
YDS6CA	6 (7)	3	161	W161 (2)	U161 (1)*	†	‡	—	—
YDS4CA	4 (7)	2-5/8	162	W162 (4)	U162 (1)*	†	‡	—	—
YDS2CA	2 (7)	3-7/8	163	W163 (6)	U163 (2)*	†	‡	—	—
YDS25AT	1/0 (7)	7-1/4	BG or 243	BG (12) or W243 (6)	BG (3) or U243 (3)	†	‡	—	—
YDS26AT	2/0 (7)	9-1/4	245	W245 (8)	U245 (4)	†	‡	—	—
YDS27AT	3/0 (7, 19)	7-1/4	247	W247 (8)	U247 (4)	†	‡	C247 (2)	L247 (2)
YDS28AT	4/0 (7, 19)	10-1/2	249	W249 (12)	U249 (6)	†	‡	C249 (3)	L249 (3)
YDS29AT	250 (19)	7-1/2	616	—	U616 (6)	†	‡	—	—
YDS291AT	266.8 (7, 19)	8-5/8	251	—	U251 (7)	†	‡	C251 (4)	L251 (4)
YDS301AT	336.4 (19, 37)	9-7/8	321	—	U321 (8)	†	‡	C321 (4)	L321 (4)
YDS31AT	350 (19)	11	490	—	U490 (9)	†	‡	C490 (5)	L490 (5)
YDS311AT	397.5 (19)	12-1/4	468	—	U468 (10)	†	‡	—	—
YDS331AT	477 (19)	12-3/4	317	—	U317 (9)	†	‡	C317 (3)	L317 (3)
YDS351AT	556.5 (19, 37)		261	—	U261 (9)	†	‡	C261 (3)	L261 (3)
YDS361AT	636 (37)	13-1/2	469	—	—	S469 (12)	P469 (8)	C469 (4)	L469 (4)
YDS391AT	795 (37, 800 (61))	13-5/8	342	—	—	S342 (8)	P342 (8)	C342 (4)	L342 (4)
YDS431AT	954 (37, 61)	17-5/8	352	—	—	S352 (10)	P352 (10)	C352 (5)	L352 (5)

\* Multiple crimp die set; makes more than one crimp per tool compression. Figure indicates number of compressions.

† U Die with adapter PT-6515.  
‡ U Die with adapter PUADP-1.

H-53

Blue highlighted items are industry standard and most frequently ordered.

## TYPES YDS & YDS-C

### HYSPLICE™

Full Tension Sleeve for Stranded Copper Conductors

Made of pure copper tubing. Designed to develop the full rated breaking strength of hard drawn or medium hard drawn copper conductor. Installed with standard tooling.



H-54

Catalog Number	Stranded Conductor	L	Die Index	Tools, Die Set Catalog Number, & (Number of Crimps)			
				MD7, MD6	Y35, Y750, Y45†, Y46‡	Y48B	Y60BHU
YDS6C	6 (7)	2-3/4	161	W161 (2)	U161 (1)*	—	—
YDS4C	4 (7)	2-5/8	162	W162 (4)	U162 (1)*	—	—
YDS3C-3	3 (3)	5-1/4	163	W163 (9)	U163 (3)*	—	—
YDS2C	2 (7)	3-5/8	163	W163 (6)	U163 (2)*	—	—
YDS2C-3	2 (3)	3-5/8	163	W163 (6)	U163 (2)*	—	—
YDS1C	1 (7, 19)	4-1/4	164	W164 (6)	U164 (3)*	—	—
YDS1C-3	1 (3)	6-1/4	459	—	U459 (6)	—	—
YDS25	1/0 (7, 19)	5-3/8	165	W165 (6)	U165/U205 (6)	—	—
YDS26	2/0 (7, 12, 19)	6	166	W166 (12)	U166/U459 (6)	—	—
YDS27	3/0 (7, 19)	6-3/4	167	—	U167/U568 (7)	—	—
YDS28	4/0 (7, 12, 19)	6-7/8	168	—	U168 (9)	C168 (3)	L168 (3)
YDS29	250 (7, 19, 37)	7-1/2	169	—	U169 (9)	C169 (3)	L169 (3)
YDS30	300 (19, 37)	8-1/8	170	—	U170 (13)	C170 (3)	L170 (3)
YDS31	350 (12, 19, 37)	10-1/4	267	—	U267 (12)	C267 (4)	L267 (4)
YDS32	400 (19, 37)	12-3/4	209	—	U209 (15)	C209 (5)	L209 (5)
YDS34	500 (19, 37)	11-5/8	210	—	U210 (15)	C210 (5)	L210 (5)
YDS39	750 (37)	12-3/4	627	—	—	C627 (7)	L627 (7)
YDS44	1000 (61, 37)	15-1/4	345	—	—	C345 (10)	L345 (10)

\* Multiple crimp die set; makes more than one crimp per tool compression. Figure indicates number of compressions.

† U Die with adapter PT-6515.

‡ U Die with adapter PUADP-1.

Blue highlighted items are industry standard and most frequently ordered.

**TYPES YDS-W & YDS**

**HYSPLICE™**

Full Tension Sleeve for Solid Copper Conductors

YDS-W is designed to develop full rated breaking strength of hard drawn and medium hard drawn solid copper conductor. Made of pure copper tubing. Installed with standard tooling.

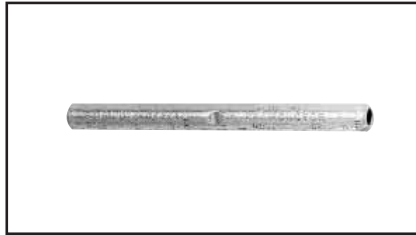

RUS Accepted

Catalog Number	Solid Conductor	L	Die Index	Tools, Die Set Catalog Number, & (Crimps per End)			
				MD7, MD6	Y35, Y750, Y45†, Y46‡	Y48B	Y60BHU
<b>YDS8WG1</b>	8	1-7/8	161	W161 (1)	U161 (1)	—	—
<b>YDS8W</b>	8	1-1/2	171	W171 (1)	U171 (1)*	—	—
<b>YDS6W</b>	6	2-5/8	161	W161 (2)	U161 (1)*	—	—
<b>YDS4W</b>	4	2-1/2	162	W162 (4)	U162 (1)*	—	—
<b>YDS3W</b>	3	2-7/8	163 or 308	W163 (4) —	U163 (1)* U308 (2)*	—	—
<b>YDS2W</b>	2	3-3/4	163	W163 (6)	U163 (2)*	—	—
<b>YDS1W</b>	1	5-7/8	164	W164 (8)	U164 (4)*	—	—
<b>YDS75</b>	1/0	6-1/4	165	W165 (6)	U165/U205 (6)	—	—
<b>YDS76</b>	2/0	6-5/8	166	W166 (12)	U166/U459 (6)	—	—
<b>YDS78</b>	4/0	7-7/8	168	—	U168 (9)	C168 (3)	L168 (3)

\* Multiple crimp die set; makes more than one crimp per tool compression. Figure indicates number of compressions.

† U Die with adapter PT-6515.

‡ U Die with adapter PUADP-1.

H-55

Blue highlighted items are industry standard and most frequently ordered.

**TYPES YDS-R SET,  
YDS-RP1  
(Aluminum Sleeve)  
YDS-RP2  
(Steel Sleeve)**



**HYSPLICE™**

Full Tension Sleeve for ACSR,  
Compressed and Compact  
Conductors

RUS Accepted

Two-piece, full tension HYSPLICE™, consists of aluminum outer sleeve and steel inner sleeve. Tapered outer sleeve provides gradual transition of stress. Filler holes provided for PENETROX™ joint compound. Sizes 1/0 and larger supplied with plugs for filler hole. Installed with standard HYSPLICE™ tools and dies (thru 556 with Y35 or Y750 HYPRESS™). Aluminum and steel sleeves can be ordered separately or in sets.

H-56

Catalog Number		Conductor	L	Die Index	Tools, Die Set Catalog Number, & (Crimps per End)				
Set	Sleeves				MD7, MD6	Y35, Y750, Y45†, Y46‡	Y48B	Y60BHU	
YDS021R	Steel	2 (7-1)	4-3/4	242	W242 (8)	U242 (4)	—	—	
	Alum.								YDS25RP2 YDS021RP1
YDS1R	Steel	1 (6-1)	4-1/8	240	W240 (6)	U240 (3)	—	—	
	Alum.								YDS1RP2 YDS1RP1
YDS25R	Steel	1/0 (6-1)	4-3/4	242	W242 (8)	U242 (4)	—	—	
	Alum.								YDS25RP2 YDS25RP1
YDS26R	Steel	2/0 (6-1)	5-1/4	242	W242 (8)	U242 (4)	—	—	
	Alum.								YDS26RP2 YDS26RP1
YDS27R	Steel	3/0 (6-1)	5-1/4	248	W246 (16)	U248 (8)	C248 (3)*	L248 (3)*	
	Alum.								YDS27RP2 YDS27RP1
YDS28R	Steel	4/0 (6-1)	5-1/8	248	W248 (14)	U248 (7)	C248 (2)*	L248 (2)*	
	Alum.								YDS28RP2 YDS28RP1
—	Steel	266.8 (18-1)	4-1/8	240	W240 (6)	U240 (3)	—	—	
	Alum.								YDS1RP2 YDS291RP1
YDS30R	Steel	266.8 (26-7)	6	250	—	U250 (10)	C250 (8)	L250 (8)	
	Alum.								YDS30RP2 YDS30RP1
YDS321R	Steel	336.4 (18-1)	4-3/4	242	W242 (8)	U242 (4)	C242 (2)*	L242 (2)*	
	Alum.								YDS25RP2 YDS321RP1
YDS32R	Steel	336.4 (26-7)	6-7/8	252	—	U252 (9)	C252 (3)	L252 (3)	
	Alum.								YDS32RP2 YDS33RP1
YDS33R	Steel	336.4 (30-7)	8-5/8	305	—	U305 (9)	C305 (3)	L305 (3)	
	Alum.								YDS41RP2 YDS33RP1
YDS34R	Steel	397.5 (26-7)	6-1/4	253	—	U253 (9)	C253 (3)	L253 (3)	
	Alum.								YDS34RP2 YDS35RP1
YDS35R	Steel	397.5 (30-7)	8	255	—	U255 (12)	C255 (4)	L255 (4)	
	Alum.								YDS44RP2 YDS35RP1
YDS361R	Steel	477 (18-1)	5-1/4	248	W248 (16)	U248 (8)	C248 (4)*	L248 (4)*	
	Alum.								YDS27RP2 YDS361RP1
YDS326R	Steel	477 (24-7)	6-1/4	253	—	U253 (9)	C253 (3)	L253 (3)	
	Alum.								YDS34RP2 YDS37RP1
YDS36R	Steel	477 (26-7)	7-7/8	350	—	U350 (12)	C350 (4)	L350 (4)	
	Alum.								YDS36RP2 YDS37RP1

\* Multiple crimp die set; makes more than one crimp per tool compression. Figure indicates number of compressions.

† U Die with adapter PT-6515.

‡ U Die with adapter PUADP-1.

Blue highlighted items are industry standard and most frequently ordered.



**TYPES YDS-R SET,  
YDS-RP1  
(Aluminum Sleeve)  
YDS-RP2  
(Steel Sleeve)  
(Continued)**

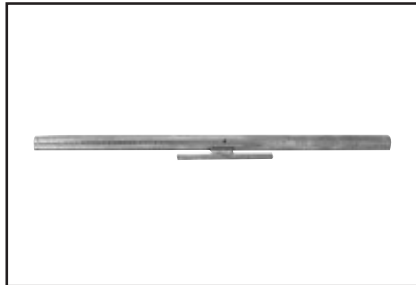

Full Tension Sleeve for ACSR  
and Compressed and Compact  
Conductors

RUS Accepted

Catalog Number		Conductor	L	Die Index	Tools, Die Set Catalog Number, & (Crimps per End)						
Set	Sleeves				MD7, MD6	Y35, Y750	Y45	Y46	Y48B	Y60BHU	
YDS392R	Steel	YDS41RP2	556.5 (24-7)	8-5/8	305	—	U305 (9)	†	‡	C305 (3)	L305 (3)
	Alum.	YDS39RP1		26-1/8	608	—	U608 (15)	†	‡	C608 (5)	L608 (5)
—	Steel	YDS44RP2	556.5 (26-7)	8	255	—	U255 (12)	†	‡	C255 (4)	L255 (4)
	Alum.	YDS39RP1		26-1/8	608	—	U608 (15)	†	‡	C608 (5)	L608 (5)
—	Steel	YDS43RP2	636 (24-7)	8	254	—	—	S254 (15)	P254 (15)	C254 (5)	L254 (5)
	Alum.	YDS43RP1		32-1/2	319	—	—	S319 (18)	P319 (18)	C319 (6)	L319 (6)
YDS43R45RS	Steel	YDS45RP2	636 (26-7)	9	320	—	—	S320 (15)	P320 (15)	C320 (5)	L320 (5)
	Alum.	YDS43RP1		32-1/2	319	—	—	S319 (18)	P319 (18)	C319 (6)	L319 (6)
YDS43R43RS	Steel	YDS43RP2	666.6 (24-7)	8	254	—	—	S254 (15)	P254 (15)	C254 (5)	L254 (5)
	Alum.	YDS43RP1		32-1/2	319	—	—	S319 (18)	P319 (18)	C319 (6)	L319 (6)
YDS451R49RS	Steel	YDS49RP2	795 (26-7)	10	419	—	—	S419 (21)	P419 (21)	C419 (7)	L419 (7)
	Alum.	YDS451RP1		32-1/2	579	—	—	S579 (18)	P579 (18)	C579 (6)	L579 (6)
YDS45R45RS	Steel	YDS45RP2	795 (54-7)	9	320	—	—	S320 (15)	P320 (15)	C320 (5)	L320 (5)
	Alum.	YDS45RP1		32-1/2	352	—	—	S352 (18)	P352 (18)	C352 (6)	L352 (6)
YDS451R34RS	Steel	YDS34RP2	900 (45-7)	6-1/4	253	—	U253 (9)	†	‡	C253 (3)	L253 (3)
	Alum.	YDS451RP1		32-1/2	579	—	—	S579	P579	C579 (6)	L579 (6)
—	Steel	YDS49RP2	1033.5 (54-7)	10	419	—	—	—	—	C419 (7)	L419 (7)
	Alum.	YDS49RP1		37	422	—	—	—	—	—	L422 (8)
—	Steel	YDS36RP2	1113 (45-7)	7-7/8	350	—	U350 (12)	†	‡	C350 (4)	L350 (4)
	Alum.	YDS49RP1		37	422	—	—	—	—	—	L422 (8)

\*† U Die with adapter PT-6515.  
‡ U Die with adapter PUADP-1.

**FOR ACSR “STATIC” WIRE**

Catalog Number		Conductor	L	Die Index	Tools, Die Set Catalog Number, & (Crimps per End)				
Set	Sleeves				MD7, MD6	Y35, Y750, Y45†, Y46‡	Y48B	Y60BHU	
YDS011R	Steel	YDS27RP2	80 (1-8)	5-1/4	248	W248 (16)	U248 (8)	—	—
	Alum.	YDS011RP1		19-3/4	245	W245 912)	U245 (6)	—	—
YDS251R	Steel	YDS34RP2	101.8 (12-7)	6-1/4	253	—	U253 (9)	C253 (3)	L253 (3)
	Alum.	YDS251RP1		22-1/4	316	—	U316 (9)	C316 93)	L316 (3)
YDS261R	Steel	YDS41RP2	134.6 (12-7)	8-5/8	305	—	U305 (9)	C305 (3)	L305 (3)
	Alum.	YDS261RP1		22-1/4	316	—	U316 (9)	C316 (3)	L316 (3)
YDS271R	Steel	YDS44RP2	159 (12-7)	8	255	—	U255 (12)	C255 (4)	L255 (4)
	Alum.	YDS271RP1		25-5/8	317	—	U317 (12)	C317 (4)	L317 (4)

† U Die with adapter PT-6515.  
‡ U Die with adapter PUADP-1.

Blue highlighted items are industry standard and most frequently ordered.

H-57

## TYPE YDS-RLY

### UNISPLICE™ SINGLE-SLEEVE

Tension Single Sleeve for ACSR, Aluminum, 6201 and 5005

Single sleeve splice similar to UNISPLICE™ type YDS-RL, except designed to eliminate possible conductor basketing on ACSR. Installed by *crimping from end of connector towards center* with standard tooling. Supplied pre-filled with PENETROX™ joint compound and capped. Factory installed plugs in pressure relief holes must be in place when conductors are inserted. Plugs drop out when sleeve is crimped.

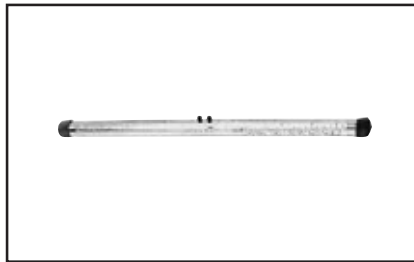

RUS Accepted

H-58

Catalog Number	Conductor †††	L	Die Index	Tools, Die Set Catalog Number, & (Crimps per End)			
				MD7, MD6	Y35, Y750, Y45†, Y46‡	Y48B	Y60BHU
YDS4RLY	4 ACSR (7-1) 4 ACSR (6-1) 4 6201 (7) 4 5005 (7) 4 AAC (7)	12-1/2	BG, or 687, or 243	BG (24)	U-BG (8)*	—	—
				W-BG (12)*	—	—	—
				W687 (12)	—	—	—
				Non-Bow**	—	—	—
				—	U243 (6)	C243 (3)	L243 (3)
YDS2RLY	2 ACSR (6-1) 2 6201 (7) 2 5005 (7) 2 AAC (7)	12-3/8	BG, or 687, or 243	BG (20)	U-BG (8)*	—	—
				W-BG (10)*	—	—	—
				W687 (10)	—	—	—
				Non-Bow**	—	—	—
				—	U243 (6)	C243 (3)	L243 (3)
YDS021RLY	2 ACSR (7-1) 2 ACSR (6-1) 2 6201 (7) 2 AAC (7)	14-3/8	C, or 167, or 247, or 702	W-C (28)	—	—	—
				—	U167 (14)	C167 (7)	L167 (7)
				—	U247 (7)	—	—
				W702 (11) Non-Bow*	—	—	—
YDS25RLY	1/0 ACSR (6-1) 1/0 6201 (7) 1/0 5005 (7) 1/0 AAC (7)	17	C, or 660, or 167, or 247, or 702	W-C (32)	—	—	—
				W660 (16)	U660 (8)	—	—
				—	U167 (16)	C167 (5)	L167 (5)
				—	U247 (8)	—	—
				W702 (12) Non-Bow**	—	—	—
YDS26RLY	2/0 ACSR (6-1) 2/0 6201 (7) 2/0 5005 (7) 2/0 AAC (7)	15	659	—	U659 Crimps Overlap	—	—
YDS27RLY	3/0 ACSR (6-1) 3/0 6201 (7) 3/0 5005 (7) 3/0 AAC (7)	21	658	—	U658 Crimps Overlap	—	—
YDS28RLY	4/0 ACSR (6-1) 4/0 6201 (7) 4/0 5005 (7) 4/0 AAC (7)	21	654	—	U654 Crimps Overlap	—	—
YDS321RLY	336.4 ACSR (18-1) 336.4 AAC (19)	20-1/2	655	—	U655 Crimps Overlap	—	—

\* Multiple crimp die set; makes more than one crimp per tool compression. Figure indicates number of compressions.

\*\* MD6 NON-BOW Dies produce straight sleeves without rotating tool.

‡ U Die with adapter PUADP-1.

† U Die with adapter PT-6515.

††† Accommodates ACSR with aluminized steel core.

Blue highlighted items are industry standard and most frequently ordered.

**TYPES YDS-RL & YDS-LT**

**UNISPLICE™**

Tension Single Sleeve for ACSR, All Aluminum, 5005, 6201, Compressed Conductors

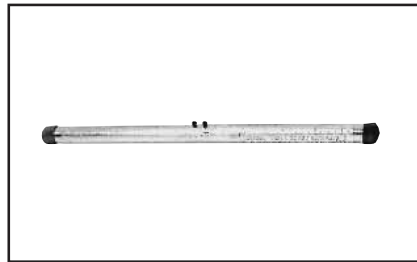

RUS Accepted

Single-sleeve aluminum UNISPLICE™ designed to splice ACSR as simply as all-aluminum. Pre-filled with PENETROX™ joint compound and capped. Eliminates strand stripping, installing separate steel sleeve and filling with joint compound. Ends ACSR joint

failure due to faulty positioning of sleeve and lack of joint compound. Simplifies hot-line splicing. Electrical and mechanical performance equal to two-piece sleeves.

Catalog Number	Conductor †††	L	Die Index	Tools, Die Set Catalog Number, & (Crimps per End)			
				MD7, MD6	Y35, Y750, Y45†, Y46‡	Y48B	Y60BHU
<b>YDS4RL</b>	4 ACSR (7-1) 4 ACSR (6-1) 4 6201 (7) 4 5005 (7) 4 AAC (7)	11-7/8	BG, or 243, or 687	BG (24)	U-BG (8)*	—	—
				W-BG (12)*	—	—	—
				W243 (12)	U243 (6)	C243 (3)	L243 (3)
				W687 (12)	—	—	—
				Non-Bow**	—	—	—
<b>YDS2RL</b>	2 ACSR (6-1) (7-1) 2 6201 (7) 2 5005 (7) 2 AAC (7)	10-1/4	BG, or 243, or 687	BG (20)	U-BG (8)*	—	—
				W-BG (10)*	—	—	—
				W243 (10)	U243 (5)	C243 (3)	L243 (3)
				W687 (10)	—	—	—
				Non-Bow**	—	—	—
<b>YDS021RL</b>	2 ACSR (7-1) 2 ACSR (6-1) 2 6201 (7) 2 AAC (7)	11-1/4	C, or 167, or 247, or 702	W-C (28)	—	—	—
				—	U167/U568 (16)	C167 (7)	L167 (7)
				W247 (14)	U247 (7)	—	—
				W702 (11)	—	—	—
				Non-Bow**	—	—	—
<b>YDS25RL</b>	1/0 ACSR (6-1) 1/0 6201 (7) 1/0 5005 (7) 1/0 AAC (7)	13-7/8	C, or 167, or 660, or 247, or 702	W-C (32)	—	—	—
				—	U167/U568 (14)	C167 (5)	L167 (5)
				W660 (16)	U660 (8)	—	—
				—	U247 (8)	—	—
				W702 (12)	—	—	—
<b>YDS26RL</b>	2/0 ACSR (6-1) 2/0 6201 (7) 2/0 5005 (7) 2/0 AAC (7)	13-1/2	659	—	U659	—	—
				—	Crimps	—	—
				—	Overlap	—	—
				—	—	—	—
<b>YDS27RL</b>	3/0 ACSR (6-1) 3/0 6201 (7) 3/0 5005 (7) 3/0 AAC (7)	18-1/4	658	—	U658	—	—
				—	Crimps	—	—
				—	Overlap	—	—
				—	—	—	—
<b>YDS28RL</b>	4/0 ACSR (6-1) 4/0 6201 (7) 4/0 5005 (7) 4/0 AAC (7)	18-1/4	654	—	U654	—	—
				—	Crimps	—	—
				—	Overlap	—	—
				—	—	—	—
<b>YDS321RL</b>	336.4 ACSR (18-1) 336.4 AAC (19) 350 AAC	18-1/4	655	—	U655	—	—
				—	Crimps	—	—
				—	Overlap	—	—

H-59

\* Multiple crimp die set; makes more than one crimp per tool compression. Figure indicates number of compressions.  
 \*\* MD6 NON-BOW Dies produce straight sleeves without rotating tool.

‡ U Die with adapter PUADP-1.  
 † U Die with adapter PT-6515.  
 †† Accommodates compact conductor.  
 ††† Accommodates ACSR with aluminized steel core.

Blue highlighted items are industry standard and most frequently ordered.

**TYPES YDS-RL & YDS-LT** (Continued)

**UNISPLICE™**

Tension Single Sleeve for ACSR, All Aluminum, 5005, 6201, Compressed Conductors

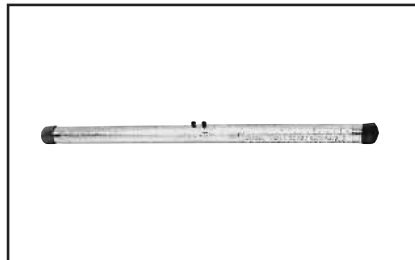

RUS Accepted

H-60

Catalog Number	Conductor	Code	L	Die Index	Tools, Die Set Catalog Number, & (Crimps per End)			
					MD7, MD6	Y35, Y750, Y45†, Y46‡	Y48B	Y60BHU
YDS30LT	312.8 6201	BUTTE		317		U317	C317	L317
YDS32LT	394.5 6201 394.5 5005 (336.4 E.C. Equiv.)	CANTON RADIANT	14-1/2	642	—	U642 (12)	C642 (4)	L642 (4)
YDS341RL	397.5 ACSR (18-1) 419.6 5005	REDE	22	327	—	U327 (18)	—	—
YDS361RL	477 (18-1) 556.5 (18-1) 587.2 5005	RUBLE	23-1/4	788 720	—	U-788 Crimps Overlap	—	L720 Crimps Overlap
YDS36LT	559.5 6201 559.5 5005 (477 E.C. Equiv.)	DARIEN REMEX	16	667	—	P667**	C667 Crimps Overlap	L667 Crimps Overlap

\*\* Y46 HYPRESS™ only.

**TYPES YDS-A & YDS-AT**

**HYSPLICE™**

Full Tension Sleeve for Aluminum (Installed with BURNDY® or EEI Dies)



Full-tension HYSPLICE™ sleeve made of aluminum and with cable stop. Designed to be installed with BURNDY® or EEI dies. BURNDY® and EEI die index numbers clearly marked on sleeve. Sizes 1/0 and larger tapered for gradual transition of stress. Pre-filled with PENETROX™ joint compound and capped.

Catalog Number	Conductor	L	EEI Die Index	Index	Tools, Die Set Catalog Number, & (Crimps per End)	
					MD7, MD6	Y35, Y750, Y45†, Y46‡
YDS2CA	2 (7)	3-7/8	6A	693	W693 (8)	U693 (2)
YDS25AT	1/0 (7)	7-1/4	8A	243	W243 (6)	U243 (3)
YDS27AT	3/0 (7, 19)	7-1/4	10A	694	W694 (8)	U694 (4)
YDS28AT	4/0 (7, 19)	10-1/2	11A	249	W249 (12)	U249 (6)
YDS311AT	397.5 (19)	12-1/4	13A	655	—	U655 (10)
YDS331AT	477 (19)	12-3/4	14A	317	—	U317 (9)

† U Die with adapter PT-6515.  
‡ U Die with adapter PUADP-1.

Blue highlighted items are industry standard and most frequently ordered.

## TYPES YDS-R & YDS-RE

### HYSPLICE™

Full Tension Sleeve for ACSR (Installed with BURNDY® EEI Dies)



Two-piece, full-tension HYSPLICE™, made of aluminum outer sleeve and steel sleeve for steel core. Designed to be installed with BURNDY® EEI dies. BURNDY® and EEI die index numbers are clearly marked on the sleeve.

Catalog Number Alum. & Steel Sleeve Set	Catalog Number Aluminum Sleeve	CONDUCTOR	Aluminum Outer Sleeve					Catalog Number Steel Sleeve	Steel Inner Sleeve				
			L	EEI Die Number	Die Index	Tools, Die Set Catalog No., & (Crimps per End)			LL	EEI Die Number	Die Index	Tools, Die Set Catalog No., & (Crimps per End)	
						MD6	Y35, Y750, Y45†, Y46‡					MD6	Y35, Y750, Y45†, Y46‡
YDS2RE	YDS021REP1	2 (6-1)	17-1/8	6A	693	W693 (20)	U693 (5)	YDS2REP2	4-1/8	1S	690	W690 (8)	U690 (4)
YDS021RE	—	2 (7-1)		8A	243	W243 (10)	U243 (5)	YDS25REP2	4-3/4	2S	691	W691 (9)	U691 (3)
—	YDS25RP1	1/0 (6-1)	19-3/4	9A	245	W245 (12)	U245 (6)	—	5-1/4	4S	692	W692 (12)	U692 (6)
—	YDS26RP1	2/0 (6-1)	16-3/4	10A	694	W694 (12)	U694 (6)	YDS27RP2	5-1/4	5S	248	W248 (8)	U248 (8)
YDS27RE	YDS27RP1	3/0 (6-1)	18-7/8	11A	249	W249 (14)	U249 (7)	YD28REP2	5-1/4	5S	248	W248 (8)	U248 (8)
YDS28RE	YDS28RP1	4/0 (6-1)	17-7/8	13A	655	—	U655 (9)	YDS25REP2	4-3/4	2S	691	W691 (9)	U691 (3)
—	—	336.4 (18-1)	25-1/2	14A	327	W327	U327 (16)	YDS27RP2	5-1/4	5S	248	W248 (8)	U248 (3)
YDS361R	YDS361RP1	477 (18-1)											

H-61

† U Die with adapter PT-6515.  
‡ U Die with adapter PUADP-1.

## TYPES YDS-E, YDS-H, YDS-U

### HYSPLICE™

Full Tension Sleeve for Steel



Full-tension HYSPLICE™ sleeves designed for HS, EHS, Utilities (UT) or Siemens-Martin (SM) galvanized steel guy, messenger, and “Static” conductors. Made of hot-dip galvanized seamless milled steel tubing lined with silicone carbide particles.

Catalog Number	Conductor			L	Die Index	Tools, Die Set Catalog Number, & (Crimps per End)		
	Size	Str.	Grade			Y35, Y750, Y45†, Y46‡	Y48B	Y60BHU
YDS250E	1/4	7	EHS	6-3/4	609	U609 (10)	—	—
YDS312H	5/16	7	HS	10-5/8	257	U257 (20)	C257 (5)*	L257 (5)*
YDS312E	5/16	7	EHS	8-1/2	305	U305 (6)	C305 (3)	L305 (3)
YDS375H	3/8	7	HS, UT	9	304	U304 (12)	C304 (4)	L304 (4)
YDS500H	1/2	7	HS	9-5/8	293	—	C293 (6)	L293 (6)

\* Multiple crimp die set makes more than one crimp per tool compression. Figure indicates number of compressions.  
† U Die with adapter PT-6515.  
‡ U Die with adapter PUADP-1.

Blue highlighted items are industry standard and most frequently ordered.

## TYPE YDS-K

### HYSPLICE™

Full Tension Sleeve  
for Copperweld

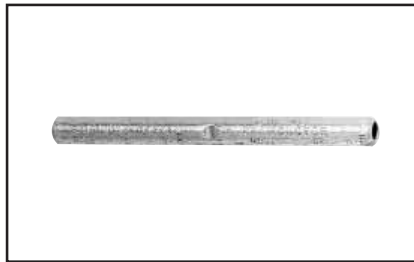

Full-tension HYSPLICE™ designed to exceed the minimum rated breaking strength of, 30% conductivity extra high strength Copperweld, and lower strength conductors. Made of pure copper tubing. Installed with HYSPLICE™ tools and dies.

H-62

Catalog Number	Conductor	L	Die Index	Tools, Die Set Catalog Number, & (Crimps per End)			
				MD7, MD6	Y35, Y750, Y45†, Y46‡	Y48B	Y60BHU
YDS8WK	8 Sol.	3-3/4	162 or 285	W162 (6)	U285 (2)	—	—
YDS6WK	6 Sol.	4-3/8	162 or 276	W162 (6)	U276 (6)	—	—
YDS3K10	(3 #10)	4-7/8	403	—	U403 (3)*	—	—
YDS3K8	(3 #8)	5-5/8	205	—	U205 (5)	—	—
YDS3K7	5/16 (7 #10) (3 #7)	10	167	—	U167/U568 (10)	C167 (4)	L167 (4)
YDS3K6	11/32 (7 #9) (3 #6)	9-1/2	331	—	U331 (9)	C331 (9)	L331 (3)
YDS3K5	3/8 (7 #8) (3 #5)	6-7/8	259	—	U259 (6)	C259 (2)	L259 (2)
YDS7K7	7/16 (7 #7)	6-7/8	328	—	—	C328 (3)	L328 (3)
YDS7K6	1/2 (7 #6)	9-3/8	260	—	—	C260 (4)	L260 (4)
YDS7K5	9/16 (7 #5)	11-3/8	344	—	—	C344 (6)	L344 (6)

\* Multiple crimp die set; makes more than one crimp per tool compression. Figure indicates number of compressions.

† U Die with adapter PT-6515.

‡ U Die with adapter PUADP-1.

## TYPE YTS-E

Full Tension Splice  
for EHS Steel

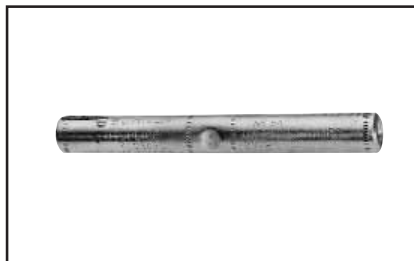

Full tension splice for EHS steel guy, messenger or "static" cable. Sleeve is pre-filled with PENETROX™ joint compound and capped.

RUS Accepted

Catalog Number	Conductor †		L	Tools, Die Sets	
	EHS Steel			Die Index	Y60BHU*
YTS375E	3/8" 7 Str.		10-3/8	723	L723
YTS438E	7/16" 7 Str.		11-7/8	726	L726

\* Overlap crimps.

† Sleeve is high strength aluminum alloy for optimum corrosion resistance.

Blue highlighted items are industry standard and most frequently ordered.

## TYPES YDS-KT & YDS-F

### HYSPLICE™

Full Tension Sleeve for Copperweld-Copper

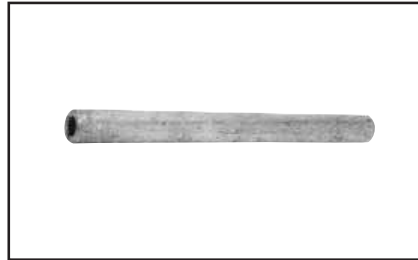

RUS Accepted

Full-tension HYSPLICE™ made of pure copper tubing. Type YDS-KT is tapered to provide gradual transition of stress on Type “A” conductor. HYSPLICE™ Type YDS-F is recommended for Type “F” conductor.

Catalog Number	Conductor	L	Die Index	Tools, Die Set Catalog Number, & (Crimps per End)			
				MD7, MD6	Y35, Y750, Y45†, Y46‡	Y48B	Y60BHU
YDS8KT	8A	5	162 or 202	W162 (4) —	— U202 (4)*	—	—
YDS6KT	6A	6-1/8	162 or 203	W162 (5) —	— U203 (5)*	—	—
YDS4KT	4A	6-3/8	163 or 204	W163 (5) —	— U204 (10)	—	—
YDS2KT	2A	7-3/4	205	—	U205 (8)	—	—
YDS3K6	4D	9-1/2	331	—	U331 (9)	C331 (3)	L331 (3)
YDS2F	2F	6-1/4	329	—	U329 (4)	—	—
YDS25F	1/0F	8-3/4	568	—	U167/U568 (8)	—	—
YDS26F	2/0F	9-5/8	552	—	U552 (11)	—	—
YDS28F	4/0F	11-7/8	331	—	U331 (12)	C331 (4)	L331 (4)

\* Multiple crimp die set; makes more than one crimp per tool compression. Figure indicates number of compressions.

† U Die with adapter PT-6515.  
‡ U Die with adapter PUADP-1.

H-63

## TYPE YDS-M-T

Full Tension Sleeve for Alumoweld



RUS Accepted

Full-tension splice for Alumoweld transmission lines. Five connectors accommodate eight conductor sizes. Sleeve is pre-filled with PENETROX™ joint compound and capped.

Catalog ††† Number	Conductor	L	Tools, Die Sets		
	ALUMOWELD		Die Index	Y35, Y750, Y45†, Y46‡	Y60BHU*
YDS7M10T	7 #10, 3 #7	10	676 or 721	U676 (8) —	— L721
YDS7M9T	7 #9, 3 #6	10-3/8	677	U677 (10)	—
YDS7M8T	7 #8, 3 #5	12-1/4	668 or 723	U668 (13) —	— L723
YDS7M7T	7 #7	14-1/2	678 or 726	U678 (19) —	— L726
YDS7M6T	7 #6	15-1/8	679 or 726	U679 (2) —	— L726

\* Overlap crimps.

† U Die with adapter PT-6515.

‡ U Die with adapter PUADP-1.

††† Sleeve is high strength aluminum alloy for optimum corrosion resistance.

Blue highlighted items are industry standard and most frequently ordered.

## DEADEND FITTING AND ACCESSORIES

### TABLE OF CONTENTS

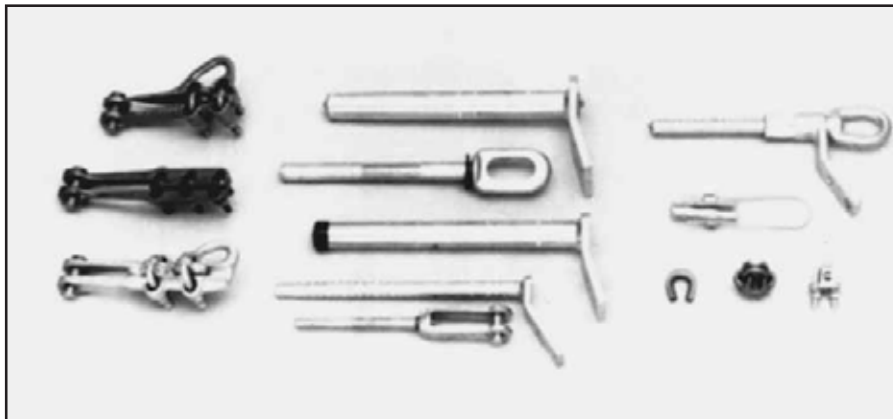

H-64

**LOOP**

Type <b>UP-R</b> .....	<b>H-65</b>
Type <b>BC</b> .....	<b>H-66</b>
Type <b>M</b> .....	<b>H-66</b>

**PRIMARY AND STRAIN BUS**

Type <b>CUW-E</b> .....	<b>H-67</b>
Type <b>DUW</b> .....	<b>H-67</b>
Type <b>CUW-A-E &amp; CUW-R-E</b> .....	<b>H-68</b>
Type <b>DUW-A &amp; DUW-A-E</b> .....	<b>H-68</b>

Blue highlighted items are industry standard and most frequently ordered.



## DEADEND FITTINGS AND ACCESSORIES

The deadend method selected for any particular application will depend upon the nature of the application, the size of the conductor, holding strength required, and preference for mechanical or compression devices.

Secondaries are commonly deadended by bending wire around a spool insulator and snubbing with the same connectors used for the secondary to service drop connection. On copper conductor, connectors such as U-bolt Clip BC, SERVIT™ KS, OKLIP™ KVS or CRIMPIT™ YC-C are recommended. These connectors provide high holding strength without damaging conductor strands. On aluminum wires, CLIPIT™ UW-R, mechanical connector is recommended.

The same methods can also be used on primaries. However, the straight line clamp Type CUW-A-E is more popular for this application. They are easier to install on either hot or de-energized lines. They are particularly well suited to hot-line maintenance, and allow easy re-sagging of conductors.

Straight line types are also popular for dead-ending strain buses. These are normally large, hard to handle conductors that do not lend themselves to snub or "quadrant" types. Types DUW or CUW-E are recommended for copper conductor and DUW-A and DUW-A-E for aluminum and ACSR. The pulling eye on the DUW-A-E is in line with the cable to make installation easier.

H-65

## TYPE UP-R

### HEAVY DUTY PARALLEL CLAMP

For All Combinations of Copper, Aluminum†, ACSR†, 6201 and 5005

Heavy duty aluminum connector for feeder, subtransmission and primary distribution. Massive design and large spacer give maximum protection against galvanic action and overload conditions. Spacing of U-bolts, tapered bell mouths and modified V groove minimize cold flow, eliminate cable damage, and produce wiping action on conductors. Spacer taps confine cable strands to prevent splaying. Captured, heat treated aluminum alloy U-bolts. PENETROX™ joint compound recommended for all combinations.

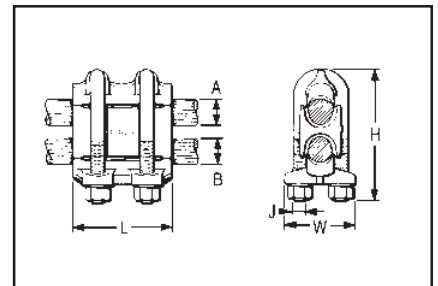

RUS Accepted

Catalog Number	Groove A		Groove B		Dimensions			
	ACSR †, 6201, 5055	Copper or Aluminum†	ACSR †, 6201, 5005	Copper or Aluminum†	H	J	L	W
UP34R	110.8 (12-7) - 397.5 (18-1)	3/0 Str. - 400	110.8 (12.7) - 397.5 (18-1)	3/0 Str. - 400	4-5/8	1/2-13	4	2-5/8
UP45R36R	336.4 (30-7) - 795 (30-19)	397.5 - 954	110.8 (12-7) - 447 (18-1)	3/0 Str. - 500	5-1/4	1/2-13	4	2-7/8
UP45R	336.4 (30-7) - 795 (30-19)	397.5 - 954	336.4 (30-7) - 795 (30-19)	397.5 - 954	6-1/4	5/8-11	4-1/2	3-1/4

† Accommodates compact and compressed conductors within diameter range.

Blue highlighted items are industry standard and most frequently ordered.

**TYPE BC**

**CLIP**

**Deadend Clamp for Guy Wire**

Deadend CLIP with DURIMUM™ silicone bronze U-bolt, nuts, and washers. Saddle made of high strength corrosion resistant copper alloy.

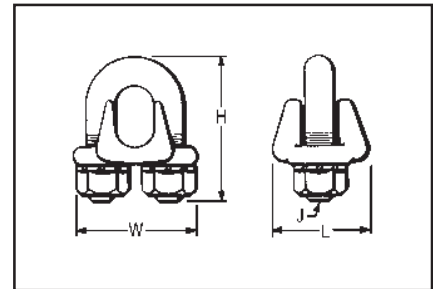

Catalog Number	Copper	Guy Wire	Dimensions			
			H	J	L	W
<b>BC2C</b>	2 Sol.	5/16	2	3/8	1-1/4	1-3/4
<b>BC25</b>	1/0 Str.	3/8			1-3/8	
<b>BC28</b>	2/0 Str. - 4/0 Str.	1/2	2-3/8	1/2	1-3/4	2-1/4

H-66

**TYPE M**

**DEADEND THIMBLE**

**Deadend Copper Conductor or Guy Wire**

High strength corrosion resistant copper alloy thimble groove to fit any size guy wire used for deadending. Generous radius prevents kinking or overstressing outer strands of wire.

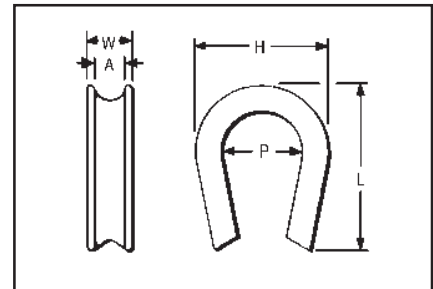

Catalog Number	Groove Size A	Dimensions			
		H	L	P	W
<b>M20</b>	5/16	1-5/8	1-7/8	7/8	5/8
<b>M30</b>	3/8	1-7/8	2-1/8	1	
<b>M40</b>	7/16	1-3/4	2-5/8	1-1/8	
<b>M50</b>	1/2	1-7/8	2-1/4		7/8
<b>M60</b>	5/8	2-1/4	2-5/8	1-3/8	
<b>M70</b>	3/4	2-5/8	3-1/4	1-1/2	1
<b>M80</b>	7/8	3	3-3/8	1-3/4	1-1/4
<b>M90</b>	1	3-3/8	3-3/4	2	1-3/8

Blue highlighted items are industry standard and most frequently ordered.

**TYPE CUW-E**

**DEADEND CLAMP**

For Copper

High strength, two-bolt, cast copper alloy strain clamp with single saddle designed for short span distribution and strain bus application. Galvanized steel clevis pin, and U-bolts.

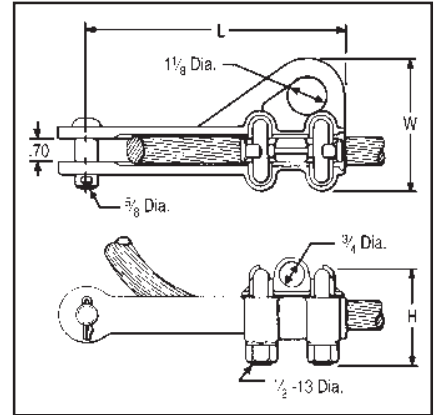
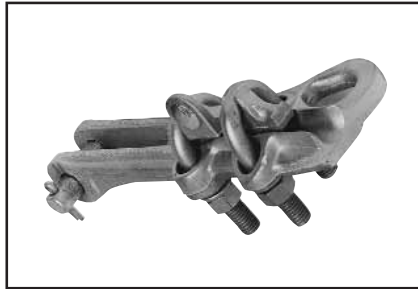

Catalog Number	Conductor Range	Dimensions		
		H	L	W
CUW34-E	4/0 Str. - 500	3	7-3/8	4
CUW44-E	500 - 1000	3-3/8	8-3/4	4-1/2

H-67

**TYPE DUW**

**DEADEND CLAMP**

For Copper

High strength corrosion resistant copper alloy strain clamp with three DURIMUM™ U-bolts and single serrated saddle. Galvanized steel clevis pin.

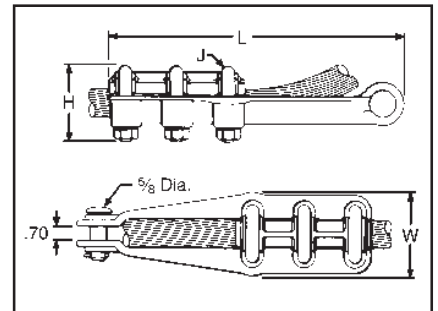

Catalog Number	Conductor	Dimensions			
		H	J	L	W
DUW28	1 Str. - 4/0 Str.	2-1/2	3/8	9-7/8	2-1/4
DUW31	4/0 Str. - 350	2			2-3/8
DUW34	350 - 500	2-5/8	1/2	11-3/8	2-3/4
DUW44	500 - 1000	2-7/8			3-1/4

Blue highlighted items are industry standard and most frequently ordered.

## TYPES CUW-A-E & CUW-R-E

### DEADEND CLAMP

For Aluminum†, ACSR†, 6201 and 5005

High strength aluminum clamp for deadending primary distribution lines. Straight-line design, with hot stick lifting-eye, pulling-eye, and captured, angled U-bolts, facilitates installation and maintenance, especially on hot-line work. Snub-pocket V-shaped, range-taking conductor groove and galvanized steel U-bolts provide high holding strength.

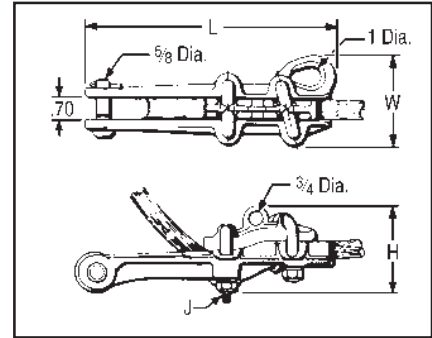
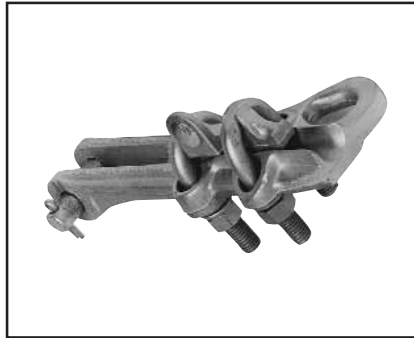

RUS Accepted

H-68

Catalog Number	Aluminum †	ACSR†, 6201, 5005	Dimensions			
			H	J	L	W
CUW26RE-1	2 Str. - 2/0 (19)	4 - 2/0	3	3/8-16	8	3
CUW30A-E	1/0 (7) - 300	1/0 - 266.8 (18-1)	3-5/8	1/2-13	10	3-1/2
CUW32R-E	3/0 (7) - 350	3/0 - 336.4 (26-7)	4	1/2-13	10	3-5/8
CUW361R-E	4/0 - 500	4/0 - 477 (18-1)	4-1/8	1/2-13	11	3-5/8
CUW391A-E	336.4 - 795	300 (26-7) 636 (26-7)	4-7/8	1/2-13	11	4-1/8

† Accommodates compressed conductors within diameter range.

## TYPES DUW-A & DUW-A-E

### DEADEND CLAMP

For Aluminum†, ACSR†, 6201 and 5005

High strength cast aluminum alloy clamp recommended for strain bus applications. Three galvanized steel U-bolts, single saddle and headed clevis pin provide high holding strength. Type DUW-A-E has pulling-eye in line with conductor for easier installation.

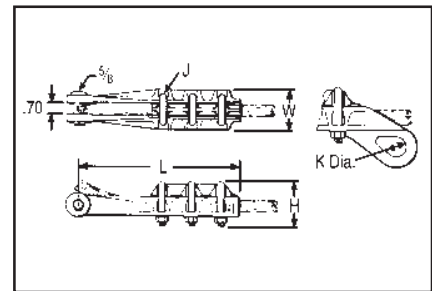
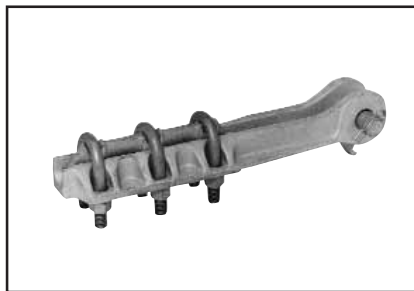

Catalog Number		Conductor		Dimensions				
Without Pulling Eye	With Pulling Eye	Aluminum†	ACSR†, 6201, 5005	H	J	K	L	W
DUW28A	—	1 - 4/0	2 (7-1) - 4/0	2	3/8	7/8	9-1/2	2-1/4
DUW44A	DUW44A-E	500 - 1000	397.5 (30-7) - 900 (54-7)	3-3/8	1/2	1-1/4	11-1/4	3-5/8

Blue highlighted items are industry standard and most frequently ordered.

**COMPRESSION TERMINALS AND ACCESSORIES**

**TABLE OF CONTENTS**

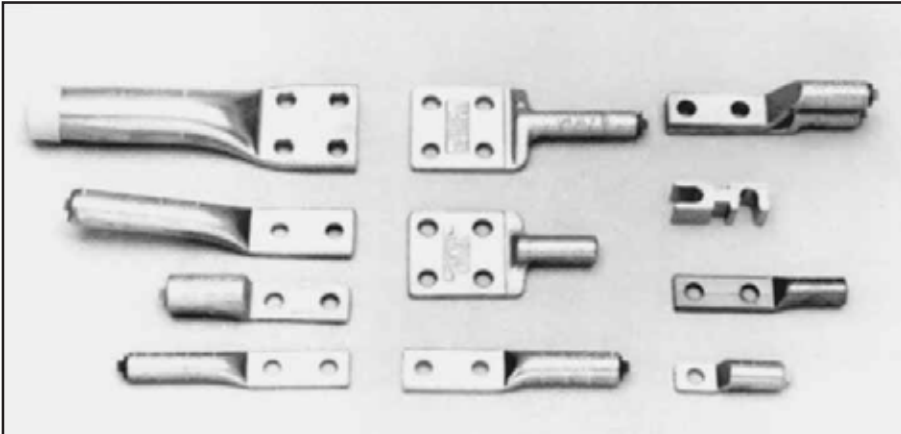

H-69

Types **YCA-2N & YCAB-4N** ..... H-70  
 Type **YCA-RL-2N** ..... H-71  
 Types **YCA-R-N & YCAK-R-N** ..... H-72, H-73  
 Type **YAK-A-2G** ..... H-74  
 Types **YCAK-A & YRA** ..... H-75

Blue highlighted items are industry standard and most frequently ordered.

## COMPRESSION TERMINALS & ACCESSORIES

Compression terminals are used to make convenient and reliable connections to switch pads, transformers, and other electrical equipment. They accommodate either copper, aluminum, ACSR, ACAR, Alumoweld, or steel conductor and come with one, two or four hole NEMA drilled pads to match the equipment drilling. Standard copper and aluminum terminals are also listed in the compression section B.

H-70

### TYPES YCA-2N & YCAB-4N

#### HYLUG™

Compression Terminal for Copper

Compression HYLUG™ terminals designed for terminating copper conductors to switch pads and other substation or switch yard apparatus. NEMA standard mounting holes. Made of pure copper. Installed with same die as equivalent full-tension jumper loop and repair sleeves.

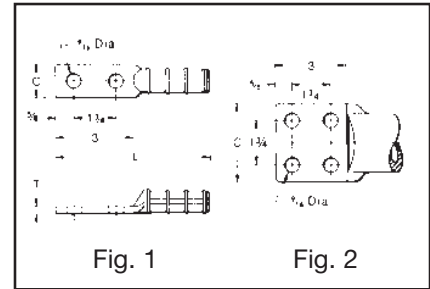
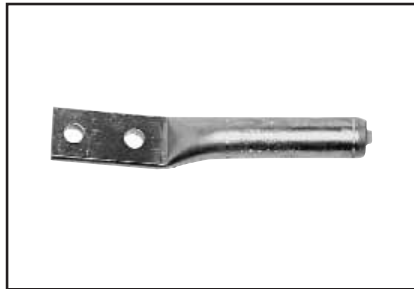

Catalog Number	Conductor	Fig. No.	C	L	T	Die Index	Tools, Die Set Catalog Number, & (Number of Crimps)			
							MD7, MD6	Y35, Y750, Y45†, Y46‡	Y48B	Y60BHU
YCA25-2N	1/0 (7, 19)	1	7/8	5-3/8	1/8	165	W165 (3)	U165/U205 (3)	—	—
YCA26-2N	2/0 (7, 19, 37)		1	5-1/4	1/4	166	W166 (6)	U166/U459 (3)	—	—
YCA27-2N	3/0 (7, 19)		1-1/8	5-3/8		167	—	U167/U568 (3)	C167 (1)	L167 (1)
YCA28-2N	4/0 (7, 12, 19)	2	1-1/4	5-5/8	3/8	168	—	U168 (3)	C168 (1)	L168 (1)
YCAB28-4N			3			—	—	—	—	
YCA29-2N	250 (7, 19, 37)	1	1-3/8	5-1/2	1/2	169	—	U169 (4)	C169 (1)	L169 (1)
YCA30-2N	300 (19, 37)		1-1/2			6-1/2	170	—	U170 (5)	C170 (1)
YCA31-2N	350 (12, 19, 37)		1-5/8	6-3/4	267	—	U267 (6)	C267 (2)	L267 (2)	
YCA32-2N	400 (19, 37)	2	3	7-1/8	3/8	209	—	U209 (6)	C209 (2)	L209 (2)
YCAB32-4N			—	—		—	—			
YCA34-2N	500 (19, 37)	1	1-7/8	6-1/2	3/8	210	—	U210 (6)	C210 (2)	L210 (2)
YCAB34-4N		2	3	6-7/8	1/2	—	—	—	—	
YCA39-2N	750 (37, 61)	1	2-3/8	7-1/4	5/8	627	—	—	C627 (3)	L627 (3)
YCAB39-4N							—	—		
YCAB44-4N	1000 (61)	2	3	7-7/8	5/8	345	—	—	C345 (4)	L345 (4)

YCAB have brazed pads.  
 † U Die with adapter PT-6515.  
 ‡ U Die with adapter PUADP-1.

Blue highlighted items are industry standard and most frequently ordered.

**TYPE YCA-RL-2N**

**HYLUG™**

Compression Terminals for Aluminum, ACSR, 6201, 5005, Compressed and Compact Conductors

Aluminum compression HYLUG™ for terminating overhead conductors to switch pads and other substation or switch yard apparatus. NEMA standard mounting holes. Installed with same die as equivalent full-tension UNISPLICE™. Pre-filled with PENE-TROX™ joint compound and capped.

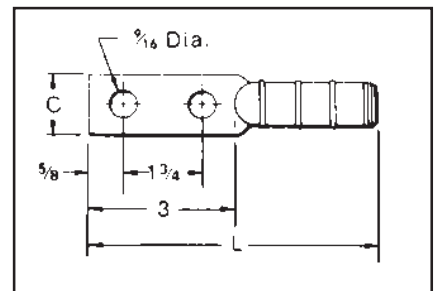
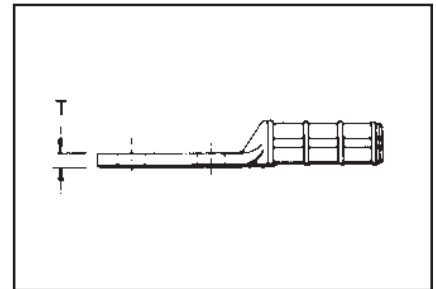

H-71

Catalog Number	Conductor	C	L	T	Die Index	Tools, Die Set Catalog Number, & Number of Crimps				
						MD7, MD6	Y35, Y750, Y45† Y46‡			
<b>YCA4RL-2N</b>	4 ACSR (6-1, 7-1) 4 6201 (7) 4 AAC (7)	7/8	6	3/8	BG, 687, 243	W-BG (8) Fixed BG (8) W687 (4)	U243			
<b>YCA2RL-2N</b>	2 ACSR (6-1, 7-1) 2 6201 (7) 2 AAC (7)	7/8	6		BG, 687, 243	W-BG (8) Fixed BG (8) W687 (4)	U243			
<b>YCA25RL-2N</b>	1/0 ACSR (6-1) 1/0 6201 (7) 1/0 5005 (7) 1/0 AAC (7)	1-1/8	7		C, or 247, or 702	WC	12	—		
						—	—	U247	3	
<b>YCA26RL-2N</b>	2/0 ACSR (6-1) 2/0 6201 (7) 2/0 5005 (7) 2/0 AAC (7)	1-1/4	6-1/2		659	—	W702	4	Non-Bow	—
						—	—	—	U659	3
<b>YCA27RL-2N</b>	3/0 ACSR (6-1) 3/0 6201 (7) 3/0 AAC (7) 3/0 AAC (7)	1-1/4	6-1/2		658	—	—	U658	3	
<b>YCA28RL-2N</b>	4/0 ACSR (6-1) 4/0 6201 (7) 4/0 5005 (7) 4/0 AAC (7)	1-1/2	6-1/2		654	—	—	U654	3	
<b>YCA321RL-2N</b>	336.4 ACSR (18-1) 336.4 AAC (19) 350 AAC	1-5/8	6-1/2	655	—	—	U655	3		

† U Die with adapter PT-6515.  
‡ U Die with adapter PUADP-1.

Blue highlighted items are industry standard and most frequently ordered.

## TYPES YCA-R-N & YCAK-R-N

Compression Terminals for Aluminum, ACSR, 6201, 5005, Compressed and Compact Conductors

Aluminum compression HYLUG™ for terminating jumper loops and equipment taps at switchpads and other substation apparatus, or to YDW-R deadends. NEMA standard mounting holes. Installed with same dies as equivalent full-tension sleeves. Pre-filled with PENETROX™ joint compound.

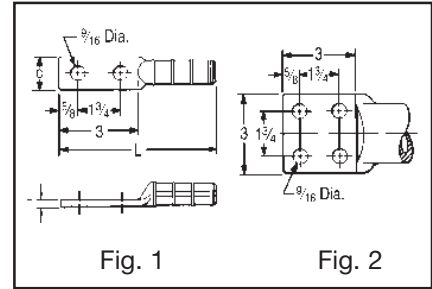

H-72

Catalog Number	Conductor		Fig. No.	C	L	T	Die Index	Tools, Die Set Catalog Number, & (Number of Crimps)					
	ACSR, 6201, 5005	Aluminum						MD7, MD6	Y35, Y750	Y45	Y46	Y48B	Y60BHU
YCA4R-2N	4	4 (7)	1	1-1/4	5-5/8	1/4	237	W237 (3)	U237 (2)	†	‡	—	—
YCA2R-2N	2	2 (7)		239	W239 (3)		U239 (2)	†	‡	—	—		
YCA25R-2N	1/0	1/0 (7, 19)	2	7/8	6-1/4	3/8	KS18, BG, or	BG (8)	U-BG (4)	†	‡	—	—
YCAK25R-4N				243, 8A	U243 (2)		U243 (2)	†	‡	C243 (2)	L243 (1)		
YCA26R-2N	2/0	2/0 (7, 19)	1	1	6-3/8	1/4	245, 9A	W245 (4)	U245 (2)	†	‡	C245 (2)	L245 (1)
YCA27R-2N	3/0 - 110.8 (12-7)	3/0 (7, 19)		1-1/8	6-3/4		247	W247 (6)	U247 (3)	†	‡	C247 (3)	L247 (2)
YCA28R-2N	4/0 (6-1, 6-7)	4/0 (7, 19)	2	1-1/4	6-7/8	3/8	K840, 249	W249 (6)	U249 (3)	†	‡	C249 (1)	L249 (2)
YCAK28R-4N				3	7-3/8		11A	†	‡	—	—		
YCA30R-2N	266.8	266.8 (7, 19)	1	1-1/2	6-3/4	1/4	251	—	U251 (4)	†	‡	C251 (2)	L251 (2)
YCAK30R-4N	(18-1, 6-7, 26-7)			2	3			7-3/8		†	‡	—	—
YCA321R-2N	336.4 (18-1)	336.4 (19) - 350 (19, 37, 61)	2	1-1/2	7	3/8	321	—	U321 (4)	†	‡	C321 (2)	L321 (2)
YCAK321R-4N				3	7-1/8			—		—	—	—	
YCA33R-2N	336.4 (26-7, 30-7)	397.5 (19)	1	1-5/8	7-1/4	1/4	316	—	U316 (4)	†	‡	C316 (2)	L316 (2)
YCAK33R-4N	397.5 (18-1)			2	3			7-3/8		—	—	—	
YCA35R-2N	397.5 (26-7, 30-7)	477 (19, 37) - 500 (37, 61)	2	1-7/8	7-1/2	3/8	317	—	U317 (4)	†	‡	C317 (2)	L317 (2)
YCAK35R-4N				3	7-3/8			—		—	—	—	
YCA361R-2N	477 (18-1)	500 (37, 61)	2	1-7/8	7-5/8	7/16	327	—	U327 (4)	†	‡	C327 (2)	L327 (2)
YCAK361R-4N				3	—			—		—	—	—	
YCA37R-2N	556.5 (18-1)	556.5 (19, 37)	1	2	8-1/8	3/8	261	—	U261 (5)	†	‡	C261 (2)	L261 (2)
YCAK37R-4N	477 (24-7, 26-7, 30-7)			2	3			—		—	—		
YCA39R-2N	556.5 (24-7, 26-7)	—	2	2-1/8	8-3/8	1/2	608	—	U608 (6)	†	‡	C608 (2)	L608 (2)
YCAK39R-4N				3	8-1/8			—		—	—	—	
YCAK361A-4N	—	636 (37)	—	—	—	—	469	—	—	S469 (6)	P469 (6)	C469 (2)	L469 (2)

\* Multiple crimp die set; makes more than one crimp per tool compression. Figure indicates number of compressions.  
 † U Die with adapter PT-6515.  
 ‡ U Die with adapter PUADP-1.  
 YCA HYLUGS™ are made from heavy walled tubing.  
 YCA4R-2N, YCA2R-2N and all YCAK HYLUGS™ are cast aluminum alloy.

(Table continued on next page.)

Blue highlighted items are industry standard and most frequently ordered.



**TYPES YCA-R-N  
& YCAK-R-N**

(Continued)

Compression Terminals for Aluminum, ACSR, 6201, 5005, Compressed and Compact Conductors

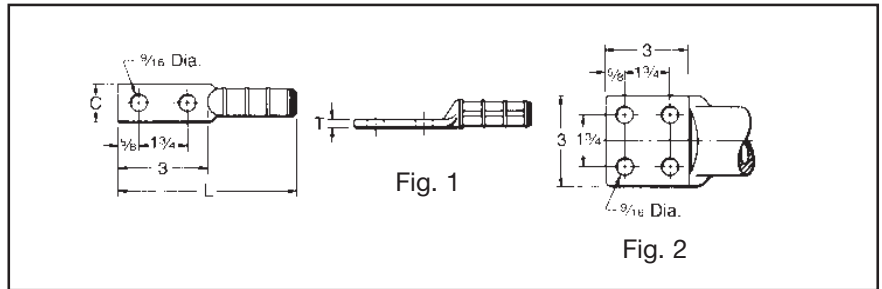

Catalog Number	Conductor		Fig. No.	C	L	T	Die Index	Tools, Die Set Catalog No., & (No. of Crimps)				
	ACSR, 6201, 5005	Aluminum						Y45	Y46	Y48B	Y60BHU	
YCA43R-2N	605 (30-19)	795 (37, 61)	1	2-1/2	10-1/4	3/4	292 or 319	S292 (6) S319 (6)	P292 (6) P319 (6)	C292 (3) C319 (3)	L292 (3) L319 (3)	
YCAK43R-4N	636 (24-7, 26-7, 30-19)	700 (61) 750 (61)	2	3	9-5/8	5/8	342	S342 (6)	P342 (6)	C342 (3)	L342 (3)	
YCA391A-2N	—	795 (37)	1	2-3/8	10-1/8							
YCAK391A-4N	—	750 (61)	2	3	9-7/8							
YCAK453R-4N	795 (36-1) 715.5 (26-7) 795 (45-7)	—			9-5/8							
YCA44A2NG2	—	1000			11							
YCA45R-2N	795 (26-7, 54-7)	900 (61, 91) 954 (37, 61)	1	2-1/2	10-1/4		352	S352 (6) S579 (6)	P352 (6) P579 (6)	C352 (3) C579 (3)	L352 (3) L579 (3)	
YCAK45R-4N		1000 (61)			9-5/8							
YCA48R-4N	900 (54-7) 954 (54-7) (45-7) 1033.5 (45-7) (36-1)	—	2	3	10		3/4	575	—	—	C575 (3)	L575 (3)
YCA441A-4N	—	1033.5 (37, 61) - 113 (61)									C575 (3)	L575 (3)
YCA451A-4N	1113 (54-19)	1272 (61)									—	L422 (3)

H-73

Blue highlighted items are industry standard and most frequently ordered.

## TYPE YAK-A-2G

### STACKING HYLUG™

For Aluminum

Cast aluminum HYLUG™ with a special tongue configuration for stacking of conductors on two and four hole NEMA transformer or equipment terminal pads. Up to eight conductors may be stacked on one four hole NEMA pad. HYLUG™ is pre-filled with PENETROX™ joint compound and capped.

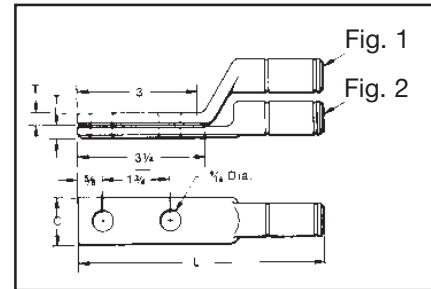
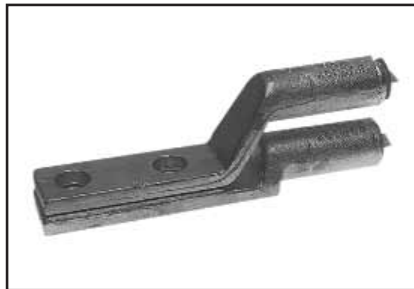

H-74

Catalog Number	Fig. No.	Conductor	C	L	T	Die Index	Tools, Die Set Catalog Number, & (Number of Crimps)			
							MD7, MD6 Series	Y35, Y750	Y45	Y46
YAK2CA2G1	1	2 Str.	7/8	5-5/8	1/4	BG	BG (3)	U-BG (1)	†	‡
YAK2CA2G2	2					K 5/8	W-BG (1)	UK 581T (3)	†	‡
YAK25A-2G1	1	1/0 Str.	7/8	5-5/8	1/4	243	W243 (1)	U243 (1)	†	‡
YAK25A-2G2	2									
YAK28A-2G1	1	4/0 Str.**	1-1/8	6-1/4	5/16	249	W249*	U249*	†	‡
YAK28A-2G2	2					K840	W-K840*		†	‡
YAK29A-2G1	1	250	1-5/8	6-7/8	3/8	299	—	U31ART*	†	‡
YAK31A-2G1	1	350				705		U705	†	‡
YAK31A-2G2	2									
YAK311A-2G1	1	397.5	1-5/8	7-3/4	7/16	317	—	U317*	†	‡
YAK311A-2G2	2					705		U705*	†	‡
YAK34A-2G1	1	500	1-5/8	8-1/4	5/8	608	—	U608*	†	‡
YAK34A-2G2	2					786		U786*	†	‡
YAK361A-2G1	1	600								
YAK361A-2G2	2	636								
YAK39A-2G1	1	700								
YAK39A-2G2	2	750								
YAK44A-2NG8	1	1000	8-7/8	8-7/8	302		—	S44ART*		P44ART*
YAK44A-2NG7	2									

\* Overlap crimps.  
 \*\* Accommodates 4/0 Str., Al or Cu.  
 † U Die with adapter PT-6515.  
 ‡ U Die with adapter PUADP-1.

Blue highlighted items are industry standard and most frequently ordered.

**TYPES YCAK-A & YRA**

**ALUMINUM HYLUG™**

For Aluminum, Copper or ACSR

Aluminum HYLUG™ for joining aluminum and copper cable to transformer and equipment pads. HYLUG™ is pre-filled with PENETROX™ joint compound and capped. Installed with standard tooling, five die sets install fourteen terminal size.

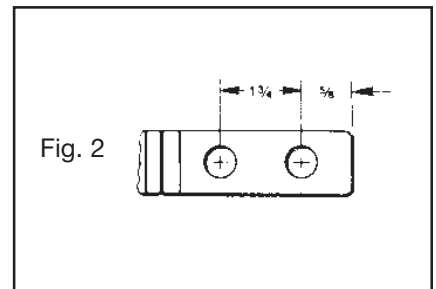
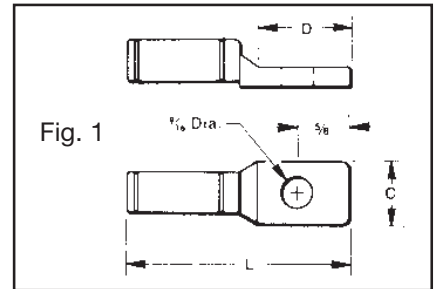
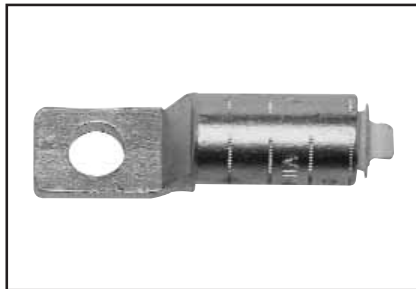

H-75

Catalog Number	Fig. No.	Conductor			C	D	L	Die Index	Die Set, Tools, Catalog Number, & (Number of Crimps)			
		Copper	Aluminum Conc. & Compact	ACSR					MD7, MD6 Series	Y35, Y750	Y45	Y46
YRA8CU-1	1	6 Sol. - 8 Sol.	8 Str.	—	15/16	1-1/16	2-9/16	BG 243	BG (3) K 5/8 243 (1)	U-BG (1) U-K-5/8-1T (3) U243 (1)	†	‡
YRA6CU-1		4 Sol. - 6 Str.	4 Sol. - 6 Str.	6 (6-1)								
YRA4CU-1		2 Sol. - 4 Str.	2 Sol. - 4 Str.	4 (6-1, 7-1)								
YRA1CU-1		1 Str. - 2 Str.	1 Str. - 2 Str.**	2 (6-1, 7-1)								
YRA25A-1		—	1/0 Str.	—								
YRAL4CU		2 Sol. - 4 Str.	2 Sol. - 4 Str.	4 (6-1, 7-1)								
YRAL1CU		1 Str. - 2 Str.	1 Str. - 2 Str.	2 (6-1, 7-1)								
YRA25U		1/0 Str.	1/0 Str.	1/0 (6-1)								
YRA26U		2/0 Str.	2/0 Str.	2/0 (6-1)								
YRA27U		3/0 Str.	3/0 Str.	—								
YRA28U	4/0 Str.	4/0 Str.	—									
YCAK28A-2G1*	2	—	—	1-1/4	3	5-5/8	317 705	—	U317* U705*	† S705*	‡ P705*	
YCAK29A-2G1*	250	250	4/0 (6-1)		1-5/16	4-1/2						
YCAK31AG1*	350	350	—		6-1/4	—						
YCAK31A-2G1*	2	—	—	1-1/2	3	6-1/2	608 786	— —	U608* U786*	† S786*	‡ P786*	
YCAK34A-2G3*		500	500									—
YCAK36A-2G1*		—	600									—
YCAK39A-2G2*		—	750									—
YCAK44A-2G2*	—	1000	—	1-11/16	—	7-1/2	302	—	—	† S44ART*	‡ P44ART*	

\* Overlap crimps.  
 \*\* YRA1CU-1 not recommended for 2 comp. conductor.  
 † U Die with adapter PT-6515.  
 ‡ U Die with adapter PUADP-1.

Blue highlighted items are industry standard and most frequently ordered.