



Surge Protection and Active Tracking® Filtering

Introduction 10

STV 200/400K Single and Three Phase Series 11

STV 100K Single and Three Phase Series..... 14

STV 25K DIN Rail Mount Series 16

STF Series Active Tracking® Filters..... 18

STFV Plus Series Active Tracking® Filters with Surge Protection..... 21

STFE Elite Series Active Tracking® Filters with Surge Protection..... 24

STC Series of Data/Signal Line Surge Protection 27



Power Conditioning

CVS Hardwired ($\pm 1\%$ Output Regulation) 34

Design Styles..... 35

MCR Hardwired ($\pm 3\%$ Output Regulation)..... 36

Connection Diagrams 38

MCR Portable ($\pm 3\%$ Output Regulation)..... 40

Model Comparison/BTU Output Chart..... 42

Operating Characteristics 43

SOLATRON™ Plus Three Phase Power Conditioners 46

Frequently Asked Questions 237

Contact **Technical Services** at **(800) 377-4384** with any questions.
 Visit our website at www.solahd.com.

Surge Protective Devices and Active Tracking® Filtering

Today's industries depend on their telecommunication, networking, computing and production equipment for optimized manufacturing performance. SolaHD's proven surge protection and filtering devices protect these critical operations across facilities from the continuous threat of transient spikes, noise and harmonic distortion.

Employing an entire facility protection strategy will safeguard the electrical system against most transients. Multi-stage protection involves clamping the initial high energy surge, filtering any remaining noise or transients to the protected sensitive equipment and finally, protecting the data/signal lines entering or leaving the control panel or the factory floor. This coordination of devices provides the lowest possible let through voltage to the equipment to ensure maximum productivity.

Surge Protective Devices

High-energy transients either externally or internally generated pose an immediate threat to the reliability and performance of your sensitive electronic equipment. Emerson Network Power Surge Protection recommends placing high-energy Surge Protective Devices (SPDs) on key panels throughout your facility. Within your facility, motors, inductive loads and various equipment load switching can cause damage or costly downtime.

Our surge protective devices focus on limiting high-voltage spikes to a level that is acceptable to most electronic equipment. Plus, they're a great first line of defense, using components that are placed in parallel with the line and serve as clamping mechanisms for high-energy impulses. Protection at this level is referred to in the industry as Sine Wave Tracking or electronic grade. Surge Protective devices are typically installed at service entrances, on larger distribution panels and at the point of use.

Active Tracking® Filtering with Surge Protection

Low-energy transients and high-frequency noise are the primary causes for system disruption and long-term degradation of microprocessor-based equipment within your facility. For more than 30 years, our Active Tracking Filters have proven to be the most effective solution in critical equipment protection within harsh industrial environments. Active Tracking Filters are built upon a unique multi-stage hybrid design. This design creates a foundation for a family of products that attenuate impulses that would normally go untouched by standard, parallel clamping devices.



Changing technology and dependence on total automation processes within modern facilities create a critical need for clean AC power at the equipment level. Active Tracking Filters are a perfect solution for your microprocessor-based products, including industrial PLCs, OEM applications and motion control systems.

Data/Signal Line Surge Protection

The rapid development of automated controls, telecommunications and fire/alarm/security systems make it imperative to have properly coordinated low-voltage surge protection. Modern networked industrial facilities require error-free transmission of information for maximum productivity and integrity of data, but these areas are often overlooked when it comes to power protection.

The need to protect all susceptible low-voltage cable routes entering a facility and at key points within the building is as critical as protecting the equipment from high-energy impulses. The importance of protecting at this level grows as your facility's reliance on sensitive instrumentation, networked automation, and uncorrupted data transmission increases. Our Data/Signal Line products utilize high-speed, high-energy components that come in a variety of voltage levels and unique packaging configurations.

Contact **Technical Services** at (800) 377-4384 with any questions.
Visit our website at www.solahd.com.

STV 200/400K Series - Surge Protective Devices

SolaHD STV 200/400K Series offers continuous protection from damaging voltage transients and electrical noise commonly found at the service entrance or distribution panel. The modular design of the STV 200/400K allows for installation flexibility and its' robust design allows for installation in the most severe exposure locations. They are capable of handling the high-impulse, potentially damaging transients commonly found at the service entrance or distribution panels. The modular design of the STV 200/400K allows for installation flexibility. Its robust design allows for placement in the most severe exposure locations.

The STV 200/400K utilizes patented circuitry to monitor the status of all protection modes, including neutral to ground. Should protection be unavailable in any mode, the Green LED will be extinguished, and the Red LED will be illuminated. In addition, high isolation form C dry contacts provide remote monitoring of suppression system failure, under voltage, phase and power loss. The STV 200/400K patented suppression integrity monitoring indicates failure for both shorted or opened suppression components.

These devices are designed to meet UL 1449 (third edition), UL 1283 and cUL Listed. These units are ANSI/IEEE C62.11, C62.41, C62.45 Categories A, B, and C3 tested. They are built to meet your unique requirements, and are available in hardwire, three phase configuration. They are designed for years of trouble free operation and require little or no operator intervention after installation.

Features

- Modular design allows for flexibility
- Surge current capacity of 200 to 400 kA per phase
- Industry's highest surge current repeatability
- All modes transient protection (L-N, L-G, and N-G)
- Form C contact and audible alarm status indications
- Internal/external monitoring, including neutral to ground
- UL rated 200 kAIC with component level fusing for safe operation
- EMI/RFI Filtering
- UL 1449 (third edition), UL 1283, and cUL Listed
- ANSI/IEEE C62.11, C62.41, C62.45 Categories A, B, and C3 tested
- Tested to NEMA LS1, ISO 9001
- NEMA 12 enclosure, available options NEMA 3R, 4, and 4X
- Optional rotary disconnect, transient counter, and remote monitor panel
- 5 Year Limited Warranty



Applications

The STV 200/400K Series can be a facility-wide product family and may be installed from service entrances to distribution panels to branch panels.

- Industrial Plants
- Commercial Buildings
- Institutional Facilities
- Any facility that has an environment with electronics based equipment

Related Products

- Power Conditioners
- Uninterruptible Power System
- Transformers
- STV 25K, STV 100K, STF, STFV and STC Series

Selection Table

Catalog Number	Input Voltage	
STV 400K-10Y	120/208 V	Three Phase Wye 4 wire + Ground
STV 200K-10Y	120/208V	Three Phase Wye 4 wire + Ground
STV 400K-27Y	277/480 V	Three Phase Wye 4 wire + Ground
STV 200K-27Y	277/480 V	Three Phase Wye 4 wire + Ground
STV 400K-48D	480 V	Three Phase Δ 3 wire + Ground
STV 200K-48D	480 V	Three Phase Δ 3wire + Ground

Contact **Technical Services** at (800) 377-4384 with any questions. Visit our website at www.solahd.com.

STV 200/400K Specifications

Description	Catalog Number					
	STV 200K-10Y	STV 200K-27Y	STV 200K-48D	STV 400K-10Y	STV 400K-27Y	STV 400K-48D
Input Vac	120Y/208 V	277Y/480 V	480 V	120Y/208 V	277Y/480 V	480 V
	Three Phase Wye, 4 W + G	Three Phase Wye, 4 W + G	Three Phase Delta, 3 W + G	Three Phase Wye, 4 W + G	Three Phase Wye, 4 W + G	Three Phase Delta, 3 W + G
Maximum Continuous Operating Voltage (MCOV)	120 V = 125%, All others voltages 115%					
Line Frequency	47-63 Hz					
Connection/ Mounting Type	Internally connected/Wall Mounted (Mounting hardware 1/4 in.)					
Enclosure	NEMA 12 (NEMA 3R, 4, 4x optional)					
Modes of Protection	All Modes: L-N, L-L, L-G, N-G					
Safety Agency Approvals	UL 1449 3rd Edition, UL 1283, cUL					
UL 1449 (2nd Edition) Suppressor Classification						
L-N	400 V	700 V	N/A	400 V	700 V	N/A
L-L	700 V	1,500 V	1,500 V	700 V	1,500 V	1,500 V
L-G	400 V	700 V	1,500 V	400 V	700 V	1,500 V
N-G	400 V	700 V	N/A	400 V	700 V	N/A
AIG Rating	200 kAIC					
Status Indication	LED's status indicator, Audible alarm, and Form 'C' contact only relay					
Response Time	< 0.5 nsec.					
Operating Temperature	-40°C to +50°C					
Operating Humidity	0% to 95% Non-condensing					
Noise Attenuation	50 dB Maximum					
Circuit Ampacity Limitations						
Per Phase	200 kA	200 kA	200 kA	400 kA	400 kA	400 kA
Line to Neutral	100 kA	100 kA	N/A	200 kA	200 kA	N/A
Line to Line	100 kA	100 kA	100 kA	200 kA	200 kA	200 kA
Line to Ground	100 kA	100 kA	100 kA	200 kA	200 kA	200 kA
Neutral to Ground	100 kA	100 kA	N/A	200 kA	200 kA	N/A
Warranty	5 year limited warranty					

Contact **Technical Services** at (800) 377-4384 with any questions.
Visit our website at www.solahd.com.

Dimensional Drawings

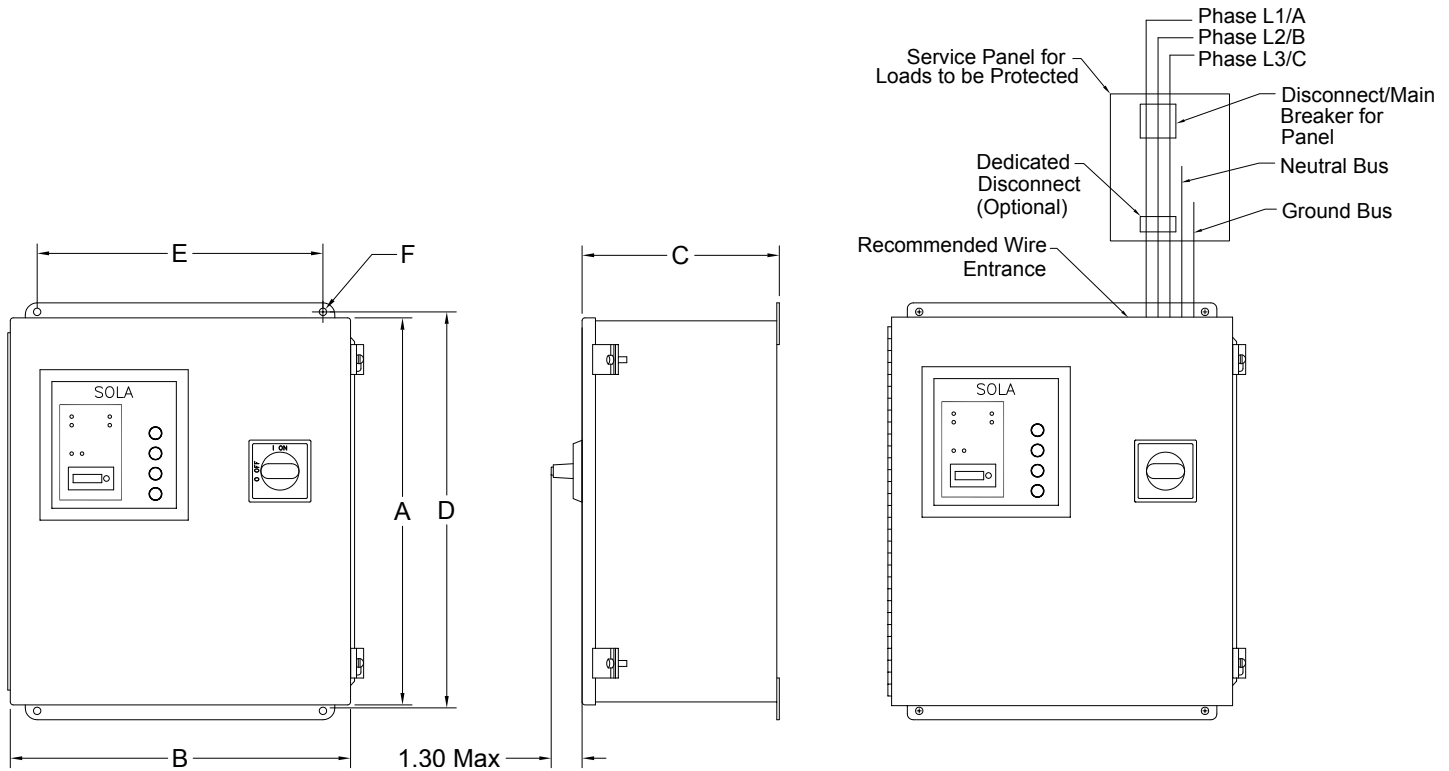

Dimensional & Wiring Specifications

STV 200/400K Series											
Catalog Number	Dimensions (in/mm)						Weight lbs (kg)	Suggested Breaker Size	Suggested Wire Size (AWG)	Allowable Breaker Range	Allowable Wire Range
	A	B	C	D	E	F					
STV 200K	16.25	14.25	8.25	16.75	12	.31	35 (15.88)	40 A	#8	15 A-100 A	#14-#2
STV 400K	16.25	14.25	8.25	16.75	12	.31	42 (19.05)	100 A	#2	15 A-100 A	#14-#2

STV 200/400K Series with Rotary Disconnect											
Catalog Number	Dimensions (inches)						Weight lbs (kg)	Suggested Breaker Size	Suggested Wire Size (AWG)	Allowable Breaker Range	Allowable Wire Range
	A	B	C	D	E	F					
STV 200K	16.25	14.25	8.25	16.75	12	.31	38 (17.23)	40 A	#8	15 A-175 A	#14-2/0
STV 400K	16.25	14.25	8.25	16.75	12	.31	45 (20.41)	100 A	#2	15 A-175 A	#14-2/0

Contact **Technical Services** at (800) 377-4384 with any questions.
 Visit our website at www.solahd.com.

The STV 100K Series - Surge Protective Devices

SolaHD's STV 100K series is a hardwired surge protective devices are designed for installation at the service entrance, branch panel or a dedicated sensitive electronic load. These units feature all mode protection, LED and audible alarm status indication, sinewave tracking and form "C" dry contacts. The STV 100K series also contains the highest levels of safety built into the product including thermal fusing and a fault current fusing level of 65 kAIC.

Features

- 100,000 amp peak current rating provides all mode protection against severe transients
- Low clamping levels for more effective protection
- 65 kAIC fault current fusing level provides safety and NEC conformance
- LED status and audible alarms
- Listed to UL 1449, 3rd Edition
- Compact, rugged metal NEMA 12 enclosure

Applications

- Distribution Panels (<1200 A)
- Branch, Lighting and Control Panels
- Factory Automation Installations
- Dedicated Industrial Equipment

Related Products

- Power Conditioners
- UPS
- Drive Isolation and K-Factor Transformers

Selection Table

Catalog Number	Input Voltage	
STV 100K-10S	120/240 V	Single Phase 3 wire + Ground
STV 100K-10Y	208Y/120 V	Three Phase Wye 4 wire + Ground
STV 100K-10N	120 V	Single Phase 2 wire + Ground
STV 100K-24L	240 V	Single Phase 2 wire + Ground
STV 100K-23Y	380Y/220 V	Three Phase Wye 4 wire + Ground
STV 100K-27Y	480Y/277 V	Three Phase Wye 4 wire + Ground
STV 100K-24D	240 V	Three Phase Δ 3 wire + Ground
STV 100K-48D	480 V	Three Phase Δ 3 wire + Ground
STV 100K-10D4	240/120 CT	Three Phase Δ 4 wire + Ground
STV 100K-24D4	480/240 CT	Three Phase Δ 4 wire + Ground



Dimensions

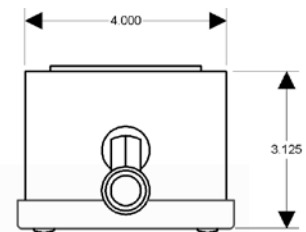

UNIT SHOWN IS A 3 PHASE WYE.

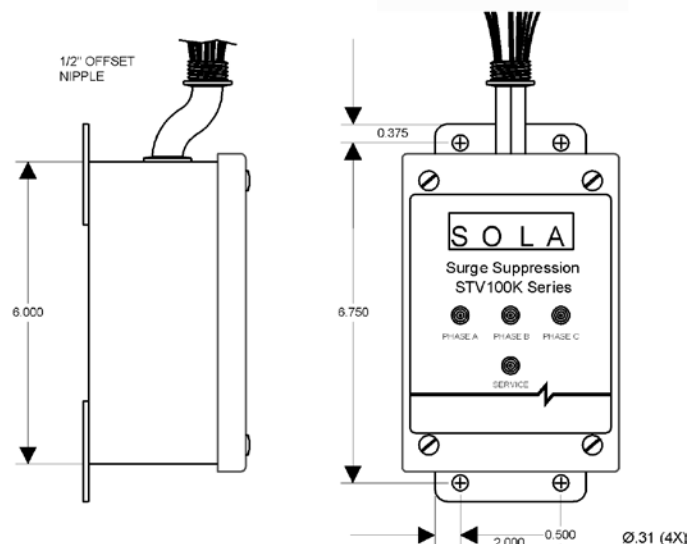

Contact **Technical Services** at (800) 377-4384 with any questions.
Visit our website at www.solahd.com.

STV 100K Specifications

Description	Catalog Number									
	STV 100K-10S	STV 100K-10N	STV 100K-24L	STV 100K-10Y	STV 100K-23Y	STV 100K-27Y	STV 100K-24D	STV 100K-48D	STV 100K-10D4	STV 100K-24D4
Input Vac	120/240 V	120 V	240 V	208Y/120 V	380Y/220 V	480Y/277 V	240 V	480 V	120/240 CT	240/480 CT
	Single Phase 3 wire + Ground	Single Phase 2 wire + Ground		Three Phase Wye 4 wire + Ground			Three Phase Δ 3 wire + Ground		Three Phase Δ 4 wire + Ground	
Maximum Continuous Operating Voltage (MCOV)	125% of the nominal level for 120 V; 115% for all other input voltages									
Line Frequency	47-63 Hz									
Connection/ Mounting Type	Parallel/Flange									
Enclosure	Metal, NEMA 12 Enclosure									
Dimensions – in (mm) (H x W x D)	4 x 6 x 4 (101.6 x 152.4 x 101.6)									
Weight (lbs/kg)	8 lb/3.63 kg max.									
Modes of Protection	All Mode: L - N, L - L, L - G, N - G									
Safety Agency Approvals	UL 1449 3rd Edition, cUL									
	UL 1449 (2nd Edition) Suppressor Classification									
L – N	400 V	400 V	N/A	400 V	800 V	800 V	N/A	N/A	400 V	800 V
L – L	800 V	N/A	800 V	800 V	1500 V	1500 V	1500 V	1500 V	800 V	1500 V
L – G	400 V	400 V	800 V	400 V	800 V	800 V	1500 V	1500 V	400 V	800 V
N – G	400 V	400 V	N/A	400 V	800 V	800 V	N/A	N/A	400 V	800 V
A/C Rating	65 kAIC									
Status Indication	3-Green LEDs, 1 per phase, 1-Red LED, Form C Contacts, Audible Alarm									
Response Time	< 0.5 nsec									
Operating Temperature	-40°C to +60°C									
Operating Humidity	0% to 95% Non-condensing									
Fusing	Thermal and Fault Current									
Noise Attenuation	40 dB Max									
	Peak Surge Current Capability									
Per Phase	100 kA	100 kA	100 kA	100 kA	100 kA	100 kA	100 kA	100 kA	100 kA	100 kA
	50 kA	50 kA	N/A	50 kA	50 kA	50 kA	N/A	N/A	50 kA	50 kA
	50 kA	N/A	50 kA	50 kA	50 kA	50 kA	50 kA	50 kA	50 kA	50 kA
	50 kA	50 kA	50 kA	50 kA	50 kA	50 kA	50 kA	50 kA	50 kA	50 kA
	50 kA	50 kA	N/A	50 kA	50 kA	50 kA	N/A	N/A	50 kA	50 kA
Line to Neutral										
Line to Line										
Line to Ground										
Neutral to Ground										
Warranty	10 years									

Contact **Technical Services** at **(800) 377-4384** with any questions.
Visit our website at www.solahd.com.

The STV 25K DIN Rail Series - Surge Protective Devices

This series provides point-of-use protection, at the dedicated equipment level, against damaging transients. Ideal for installation in electronic control cabinets found in harsh industrial environments such as the factory floor or at remote locations. These devices provide 50,000 amps of surge protection, sinewave tracking, LED status indication and form "C" dry contacts. This DIN Rail series also provides protection on all electrical paths and comes with a standard ten year product warranty. The STV 25K DIN Rail series surge protective devices are UL recognized to Standard 1449, 3rd Edition.



Selection Table

Catalog Number	Input Voltage	
	STV 25K-10S	120 V
STV 25K-24S	240 V	Single Phase (L1 - L2)

Dimensions

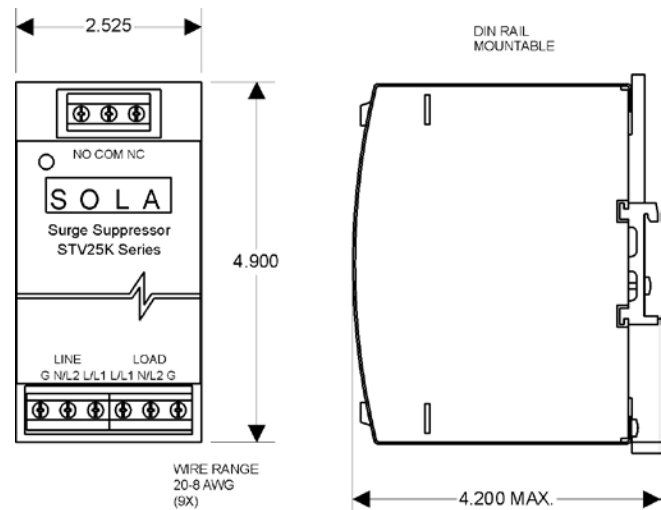

Applications (20 Amp Max)

- Control Cabinets for Industrial Automation
- Point-of-Use Industrial/Service Equipment
- Remote Commercial or Industrial Equipment
- Instrumentation and Large Test Equipment
- Commercial and Building Automation Systems

Features

- Compact and narrow design maximizes panel space.
- Low clamping levels for more effective protection.
- Easy access terminal screws for quick mounting and installation.
- 50,000 amps of surge protection.
- Sine wave tracking and all mode protection provide consistent and reliable protection on all electrical paths.
- Patented thermal fusing prevents MOV overheating caused by excessive current levels.

Related Products

- DIN Rail Power Supplies
- DIN Rail AC UPS
- Industrial Control Transformers
- Line Reactors
- Active Tracking[®] Filters

Contact **Technical Services** at (800) 377-4384 with any questions.
Visit our website at www.solahd.com.

STV 25K Specifications

Description	Catalog Number	
	STV 25K-10S	STV 25K-24S
Input Voltage	120 Vac, Single Phase 0-135 VRMS	240 Vac, Single Phase 0-260 VRMS
Maximum Continuous Operating Voltage (MCOV)	120 Vac - 150 VRMS	240 Vac - 275 VRMS
Line Frequency	47-63 Hz	
Connection/Mounting Type	DIN Rail Mount (Chassis Mount Bracket Optional order SDN-PMBRK2) with screw terminals for #12 AWG.	
Input Current Rating	20 Amps	
Phase Configuration	2 wire + GND	
Weight – lbs (kg)	3 lbs/1.36 kg	
Dimensions (H x W x D)	4.87 x 2.5 x 4.375 (12.37 x 6.35 x 11.11) includes mounting bracket	
Modes of Protection	All Mode: L - N, L - L, L - G, N-G	
Safety Agency Approvals	UL 1449 3rd Edition	
UL 1449 (3rd Edition) Suppressor Classification 120 Vac Normal/Common Mode 240 Vac Normal/Common Mode	400 Vac 800 Vac	
Status Indication	Green LED, Form C Contacts	
Packaging	Metal DIN Rail Mount Enclosure, IP20	
Response Time	< 0.5 nsec	
Operating Temperature	-40°C to +60°C	
Operating Humidity	0% to 95% Non-condensing	
	Noise Attenuation	
Normal Mode	50 dB Min	
Common Mode	40 dB Min	
	Peak Surge Current Capability (8 x 20 μs)	
Line to Neutral	25 kA	
Line to Ground	25 kA	
Neutral to Ground	25 kA	
Warranty	10 Years	

Contact **Technical Services** at **(800) 377-4384** with any questions.
Visit our website at www.solahd.com.

STF Series – Active Tracking® Filters

Low voltage/high frequency noise is caused by everyday events such as turning on machinery, motors, or equipment. Although noise is less dramatic than high voltage transients, the long term effects of these frequent disturbances can be as damaging. Filtering systems such as SolaHD Active Tracking® Filters provide clean AC power by eliminating lower voltage noise.

The SolaHD STF Series offers the original active tracking technology to guard against commonly occurring but very damaging, lower energy transients. Offering excellent noise reduction, the filter continuously tracks the input AC power line and responds instantly upon detecting extraneous high frequency noise.

The STF Series eliminates low voltage/high frequency noise via a low-pass or L-C filter. These filters are used for low energy, high frequency noise reduction and consist of a series of inductors, capacitors and resistors. STF's are load dependent which means that the series inductors located on each phase and neutral conductors are sized to handle the maximum current draw on the line. These inductors together with the capacitors and resistors form a circuit capable of absorbing a large bandwidth of noise.

These devices are designed to meet UL 1283, and CSA C22.2 for Electromagnetic Interference Filters. STF's attenuate or reduce the amplitude of noise to a minimum of 40dB that occurs in a frequency range of 50 KHz to 50 MHz. They also provide the industry's best IEEE Category "A" protection, typically reducing normal mode transients to +/- 5 volts.

Built to meet your unique requirements, these filters are available in a multitude of voltage and phase configurations. They are hardwired and designed for years of trouble free operation requiring little or no operator intervention after installation.

Active Tracking® Filters are one part of a total power quality solution. They can be used alone or in conjunction with other SolaHD products to solve more complex power quality problems.

Applications

- Branch and Control Panels
- Factory Automation Installations
- Point of Use Industrial Service Equipment
- Dedicated Industrial and Machine Tools Equipment
- Telecommunications Equipment



Features

- Non degrading, series filter technology for total durability
- High Frequency Noise filter, RLC Low-Pass filter
- Single Phase applications up to 30 Amp
- Three Phase applications up to 200 Amp
- Attenuates noise to 40 dB in frequency range of 50 kHz to 50 MHz
- Operating Temperature from -40°C to +45°C.
- Hardwired connection
- MTBF greater than 100,000 Hours, Mil Std. 217F
- UL 1283 Listed or Recognized (Single Phase models), CSA
- 10 Year Limited Warranty

Related Products

- Single and Three Phase Power Conditioners
- Uninterruptible Power System
- Transient Voltage Surge Suppressors
- Power Supplies

Contact **Technical Services** at (800) 377-4384 with any questions.
Visit our website at www.solahd.com.

Selection Table

Catalog Number	Amps	Min. Wire Size (AWG Suggested)	Fuse/Circuit Breaker Ampacity		Case Dim. (in) A x B x C	Mounting Flange Dim. (in) D x E x F	Weight lbs (kg)	Design Style
			Suggest	Max				
Single-Phase Models (120 Vac)*								
STF0025-10N	2.5	26	2.5A	3.125A	4.0 x 2.88 x 1.81	4.38 x 2.12 x 5.31	2.0 (.91)	1
STF0050-10N	5.0	22	5A	6.25A	4.0 x 2.88 x 1.81	4.38 x 2.12 x 5.31	2.0 (.91)	1
STF0075-10N	7.5	18	7.5A	9.375A	4.75 x 4.75 x 2.35	5.25 x 3.5 x 6.25	3.0 (1.36)	1
STF0150-10N	15.0	14	15A	18.75	6.25 x 4.75 x 2.35	6.75 x 3.5 x 7.75	5.0 (2.27)	1
STF0200-10N	20.0	12	20A	25A	7.75 x 4.75 x 2.35	8.25 x 3.5 x 9.0	7.0 (3.17)	1
STF0300-10N	30.0	10	30A	37.5A	7.75 x 4.75 x 2.35	8.25 x 3.5 x 9.0	8.0 (3.63)	1
Single-Phase Models (240 Vac)*								
STF0025-24L	2.5	26	2.5A	3.125A	4.0 x 2.88 x 1.81	4.38 x 2.12 x 5.31	2.0 (.91)	1
STF0050-24L	5.0	22	5A	6.25A	4.0 x 2.88 x 1.81	4.38 x 2.12 x 5.31	2.0 (.91)	1
STF0075-24L	7.5	18	7.5A	9.375A	4.75 x 4.75 x 2.35	5.25 x 3.5 x 6.25	3.0 (1.36)	1
STF0150-24L	15.0	14	15A	18.75	7.75 x 4.75 x 2.35	8.25 x 3.5 x 9.0	5.0 (2.27)	1
STF0200-24L	20.0	12	20A	25A	7.75 x 4.75 x 2.35	8.25 x 3.5 x 9.0	7.0 (3.17)	1
STF0300-24L	30.0	10	30A	37.5A	7.75 x 4.75 x 2.35	8.25 x 3.5 x 9.0	8.0 (3.63)	1
Three-Phase Models (120/208 Vac WYE)**								
STF0150-10Y	15.0	14	15A	18.75A	14 x 12 x 6	14.75 x 10.0 x 15.5	38.0 (17.24)	4
STF0300-10Y	30.0	10	30A	37.5A	14 x 12 x 6	14.75 x 10.0 x 15.5	38.0 (17.24)	4
STF0500-10Y	50.0	4	50A	62.5A	20 x 16 x 9	21.25 x 10.0 x 22.5	85.0 (38.55)	2
STF1000-10Y	100.0	2	100A	125A	20 x 16 x 9	21.25 x 10.0 x 22.5	85.0 (38.55)	2
STF2000-10Y	200.0	3/0	200A	250A	24 x 20 x 9	25.25 x 14.0 x 26.5	110.0 (49.89)	2
Three-Phase Models (240 Delta)**								
STF0150-24D	15.0	14	15A	18.75A	14 x 12 x 6	14.75 x 10.0 x 15.5	38.0 (17.24)	4
STF0300-24D	30.0	10	30A	37.5A	14 x 12 x 6	14.75 x 10.0 x 15.5	38.0 (17.24)	4
STF0500-24D	50.0	4	50A	62.5A	20 x 16 x 9	21.25 x 10.0 x 22.5	85.0 (38.55)	2
STF1000-24D	100.0	2	100A	125A	20 x 16 x 9	21.25 x 10.0 x 22.5	85.0 (38.55)	2
STF2000-24D	200.0	3/0	200A	250A	24 x 20 x 9	25.25 x 14.0 x 26.5	110.0 (49.89)	2
Three-Phase Models (277/480 V WYE)**								
STF0150-27Y	15.0	14	15A	18.75A	14 x 12 x 6	14.75 x 10.0 x 15.5	38.0 (17.24)	4
STF0300-27Y	30.0	10	30A	37.5A	14 x 12 x 6	14.75 x 10.0 x 15.5	38.0 (17.24)	4
STF0500-27Y	50.0	4	50A	62.5A	20 x 16 x 9	21.25 x 10.0 x 22.5	85.0 (38.55)	2
STF1000-27Y	100.0	2	100A	125A	20 x 16 x 9	21.25 x 10.0 x 22.5	85.0 (38.55)	2
STF2000-27Y	200.0	3/0	200A	250A	24 x 20 x 9	25.25 x 14.0 x 26.5	110.0 (49.89)	2
Three-Phase Models (480 V Delta)**								
STF0150-48D	15.0	14	15A	18.75A	10.0 x 8.0 x 6.0	10.75 x 6.0 x 11.5	38.0 (17.24)	4
STF0300-48D	30.0	10	30A	37.5A	10.0 x 8.0 x 6.0	10.75 x 6.0 x 11.5	38.0 (17.24)	4
STF0500-48D	50.0	4	50A	62.5A	14.0 x 12.0 x 6.0	14.75 x 10.0 x 15.5	85.0 (38.55)	4
STF1000-48D	100.0	2	100A	125A	20.0 x 16.0 x 9.0	21.25 x 10.0 x 22.5	85.0 (38.55)	2
STF2000-48D	200.0	3/0	200A	250A	24.0 x 20.0 x 9.0	25.25 x 14.0 x 26.5	110.0 (49.89)	2

* With barrier strip at input and output

**Units are standard in NEMA 12 hinged enclosures

Contact **Technical Services** at (800) 377-4384 with any questions.
Visit our website at www.solahd.com.

STF Specifications

Description	120 Vac Models	240 Vac Models	480 Vac Models
Input Voltage	0-150 VRMS	0-275 VRMS	0-520 VRMS
Line Frequency	50/60 Hz		
Transient Attenuation Response Time	Instantaneous		
Mean Time Between Failure (MTBF)	> 100,000 Hours (Mil Std. 217F)		
Packaging	Single phase units through 30 Amps housed in black, high impact plastic case, Vacuum impregnated magnetics, epoxy encapsulated; single phase greater than 30 Amps, 480 Vac, and three phase units housed in NEMA 12 enclosures		
Operating Temperature	-40°C to +45°C Derate Linearly to 60% at +70°C		
Load Surge Current Rating	10m sec : 5 x Nominal		
	1 sec : 3 x Nominal		
	5 sec : 2 x Nominal		
Transient Reduction	Minimum of 40dB from 50 kHz through 50 MHz. Attenuation is greater than 50 dB to the surge withstand capability Ringwave test IEEE C62.41, Category "A" (IEEE Category A Ringwave 6 kV, 200A, 100 kHz) and "B" (IEEE Category B Ringwave 6 kV, 500 A, 100 kHz).		
Safety	ANSI / UL1283, CAN/CSA C22.2 No 8. Listed or Recognized "Electromagnetic Interference Filters"		
Warranty	10 years		

Dimensional Drawings

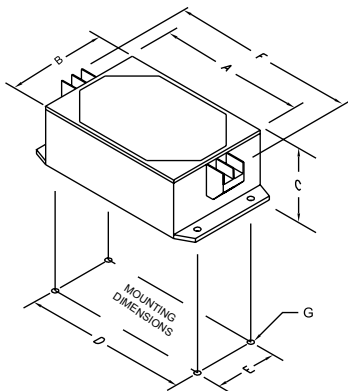

Design Style 1

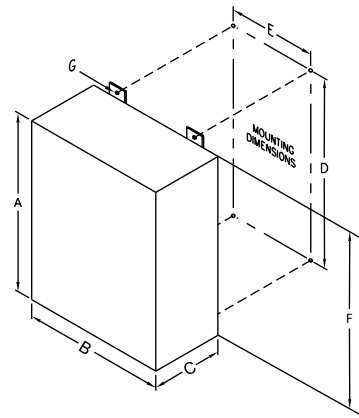

Design Style 2

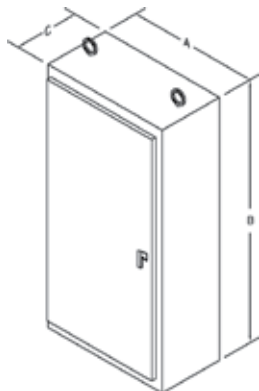

Design Style 3

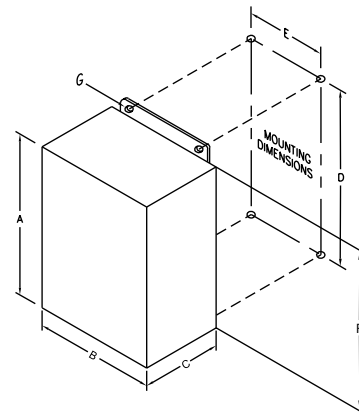

Design Style 4

Contact **Technical Services** at (800) 377-4384 with any questions.
Visit our website at www.solahd.com.

STFV Plus Series – Active Tracking® Filtering with Surge Protection



The SolaHD STFV Plus Series combines Active Tracking® filtration for low energy noise and surge protection for high energy transients. It continuously tracks the input AC power line responding instantly into action upon detecting extraneous high frequency noise and high voltage transients caused by everyday events such as turning on machinery, motors, or equipment.

These devices are designed to meet UL 1283 for Electromagnetic Interference Filters. STFV Plus attenuates or reduces the amplitude of high frequency noise to a maximum of 90dB that occurs in a range of 100 kHz to 50 MHz. STFV Plus provides the industry's best IEEE C62.41 Category "A & B" Ringwave protection.

They are built to meet your unique requirements, and are available in hardwired, single phase configuration. They are designed for years of trouble free operation and require little or no operator intervention after installation.

Active Tracking® Filters Plus is one part of a total power quality solution. They can be used alone or in conjunction with other SolaHD products to solve more complex power quality problems.

Features

- Non degrading, series Filter/TVSS technology for total durability
- UL Listed surge current capacity – 25,000 Amps
- High impact plastic case, epoxy encapsulated enclosure
- Transient protection in all modes (L-N, L-G, and N-G)
- Single Phase applications up to 30 Amp
- Operating Temperature from -40°C to +60°C
- Hardwired connection
- LED power indication
- UL 1283
- 10 Year Limited Warranty



Applications

- Branch and Control Panels
- Factory Automation Installations
- Point of Use Industrial Service Equipment
- Programmable Logic Controllers
- Dedicated Industrial and Machine tools
- Telecommunications and IT equipment

Related Products

- Power Conditioners
- Uninterruptible Power System
- Power Supplies

Contact **Technical Services** at (800) 377-4384 with any questions.
Visit our website at www.solahd.com.

Selection Table

Catalog Number	Amps	Case Dim. (in) A x B x C	Mounting Flange Dim. (in) D x E x F x G	Number Min. Wire Size (AWG Suggested)	Screw Size	Fuse/Circuit Breaker Ampacity		Weight lbs (kg)
						Suggest	Max	
Single-Phase Models (120 Vac)								
STFV025-10N	2.5	4.0 x 2.88 x 1.81	4.38 x 2.12 x 5.31 x 0.19	26	#6	2.5	3.125	1.0 (.45)
STFV050-10N	5.0	4.0 x 2.88 x 1.81	4.38 x 2.12 x 5.31 x 0.19	22	#6	5	6.25	1.3 (.59)
STFV075-10N	7.5	4.75 x 4.75 x 2.35	5.25 x 3.5 x 6.25 x 0.19	18	#6	7.5	6.25	2.0 (.91)
STFV150-10N	15.0	6.25 x 4.75 x 2.35	6.75 x 3.5 x 7.75 x 0.19	14	#8	15	18.75	3.5 (1.59)
STFV300-10N	30.0	7.75 x 4.75 x 2.35	8.25 x 3.5 x 9.0 x 0.19	10	#8	30	37.5	6.0 (2.72)
Single-Phase Models (240 Vac)								
STFV025-24L	2.5	4.0 x 2.88 x 1.81	4.38 x 2.12 x 5.31 x 0.19	26	#6	2.5	3.125	1.3 (.59)
STFV050-24L	5.0	4.75 x 4.75 x 2.35	5.25 x 3.5 x 6.25 x 0.19	22	#6	5	6.25	2.0 (.91)
STFV075-24L	7.5	6.25 x 4.75 x 2.35	6.75 x 3.5 x 7.75 x 0.19	18	#6	7.5	9.375	3.5 (1.59)
STFV150-24L	15.0	7.75 x 4.75 x 2.35	8.25 x 3.5 x 9.0 x 0.19	14	#8	15	18.75	5.8 (2.63)
STFV300-24L	30.0	7.75 x 4.75 x 2.35	8.25 x 3.5 x 9.0 x 0.19	10	#8	30	37.5	6.0 (2.72)

Dimensions

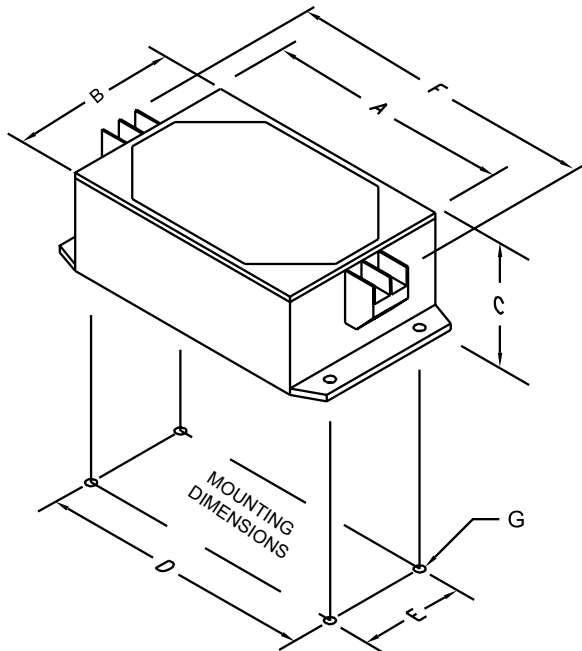

System Design

Series Blocking Inductors
smoothing inductors

Shunt Absorbing Components
sine wave tracking circuitry

MOV Transient Protection
high-energy transient protection
line to neutral, line to ground,
neutral to ground

Pulse Capacitor
high-frequency noise absorption

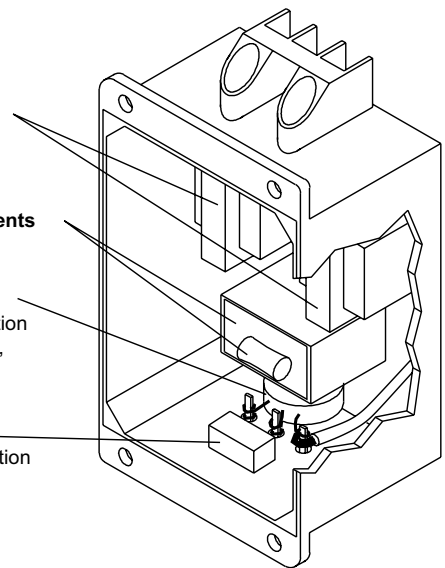

Contact **Technical Services** at (800) 377-4384 with any questions.
Visit our website at www.solahd.com.

STFV Specifications

Description	Value	
Input Voltage	120 Vac Models	0-150 VRMS
	240 Vac Models	0-275 VRMS
Line Frequency	50/60 Hz	
Configuration	Single Phase (2 wire + ground)	
Response Time	< 5 ns	
Enclosure	High impact plastic case, 94V0, Vacuum impregnated magnetics, epoxy encapsulated	
Fusing	External	
Status Indication	Green LED	
Connection/Mounting Type	Series/Panel Mount	
Operating Temperature	-40°C to +60°C at full load Derate Linearly to 60% at +70°C	
Operating Humidity	0% to 95% Non-condensing	
Mean Time Between Failure (MTBF)	Greater than 100,000 hours (Mil. Std. 217F)	
Packaging	High impact plastic case, Vacuum impregnated magnetics, epoxy encapsulated	
Peak Surge Current Capability (8 x 20 μs)	Per Phase	25,000 Amps
	Line to Neutral	12,500 Amps
	Line to Ground	12,500 Amps
	Neutral to Ground	12,500 Amps
Load Surge Current Rating	10m sec	5 x Nominal
	1 sec	3 x Nominal
	10 sec	2 x Nominal
Frequency Response (Forward Reverse)	100 kHz to 50 MHz	90 dB Max
Transient Reduction* (IEEE C62.41)	Typical Category A Ringwave (6 kV, 200A, 100 kHz)	< 10 volts peak
	Typical Category B Ringwave (6 kV, 500A, 100 kHz)	< 50 volts peak
Safety	ANSI / UL1283 Recognized "Electromagnetic Interference Filters"	
Warranty	10 years	

* All measurements in volts. IEEE test results with no AC applied.

STFE Elite Series - Active Tracking® Filters with Surge Protection



The SolaHD STF Elite DIN Rail Mount Series combines Active Tracking® technology with UL Listed surge protection to protect against the full spectrum of voltage transients and surges. It continuously tracks the input AC power line responding instantly into action upon detecting extraneous high frequency noise and high voltage transients caused by everyday events such as turning on machinery, motors, or equipment.

These devices are designed to meet UL 1449 3rd Edition, UL 1283, cUL recognized, and CE. STFE attenuates or reduces the amplitude of normal mode noise to a minimum of 90dB that occurs in a frequency range of 100KHz to 50MHz, and of common mode noise to a minimum of 60dB that occurs in a frequency range of 5MHz to 50MHz. STFE provides the industry's best IEEE C62.41 Category "A & B" Ringwave protection.

They are built to meet your unique requirements, and are available in hardwired DIN Rail mount, single phase configuration. They are designed for years of trouble free operation and require little or no operator intervention after installation.

Related Products

- Power Conditioners
- Uninterruptible Power System
- Power Supplies

Features

- Series connected DIN Rail mounted filter
- Patented durable metal mount clip
- UL Listed Surge current capacity – 45,000 Amps
- Transient protection in all modes (L-N, L-G, and N-G)
- Single Phase applications up to 20 Amp
- Operating Temperature from -40°C to +50°C
- Screw Terminal Connections
 - Reliable and convenient screw clamp connections
 - Accept 10-16 AWG wire
 - Meet IP20 specifications for ingress protection
- LED status indication
- Form C contact for remote monitoring
- UL 1449 3rd Edition, UL 1283, cUL recognized component, CE
- 5 Year Limited Warranty

Applications

- Control Panels
- Factory Automation Installations
- Point of Use Industrial Equipment
- Programmable Logic Controllers
- Dedicated Industrial and Machine Tools Equipment

Selection Table

Catalog Number	Input Voltage	
	STFE030-10N	120 V
STFE050-10N	120 V	Single Phase 2 Wire + Ground
STFE100-10N	120 V	Single Phase 2 Wire + Ground
STFE200-10N	120 V	Single Phase 2 Wire + Ground
STFE030-24L	240 V	Single Phase 2 Wire + Ground
STFE050-24L	240 V	Single Phase 2 Wire + Ground
STFE100-24L	240 V	Single Phase 2 Wire + Ground
STFE200-24L	240 V	Single Phase 2 Wire + Ground

Contact **Technical Services** at (800) 377-4384 with any questions.
Visit our website at www.solahd.com.

STFE Specifications

Description	STFEXXX-10N	STFEXXX-24L
Input Voltage	120 V (0-150 VRMS)	240 V (0-275 VRMS)
Line Frequency	47 - 63 Hz	
Response Time	< .5 ns normal mode, <5 ns common mode	
Enclosure	Fully Enclosed Metal Housing	
Fusing	Reference Fuse/Circuit Breaker Chart	
Status Indication	Green LED "OK"/Form C Contact/10 Amps @ 250 Vac or 5 Amps @ 100 Vdc	
Connection/Mounting Type	DIN Rail Mount	
Operating Temperature	-40°C to +50°C at full load Derate Linearly to 60% at +70°C	
Weight (Kg)	1.7 lbs (0.7kg)	
Dimensions – in (mm) (H x W x D)	4.88 x 2.56 x 4.56 (124 x 65 x 116)	
Operating Humidity	0% to 95% Non-condensing	
Peak Surge Current Capability	Per Phase	30,000 Amps
	Line to Neutral	20,000 Amps
	Line to Ground	10,000 Amps
	Neutral to Ground	10,000 Amps
Load Surge Current Rating	10m Sec	5 x Nominal
	1 sec	3 x Nominal
	10 sec	2 x Nominal
Frequency Response		
Normal Mode (Forward–Reverse)	100 kHz to 50 MHz	90 dB Max
Common Mode (Forward–Reverse)	5 MHz to 50 MHz	60 dB Max
Transient Reduction (IEEE C62.41)	Typical Category A Ringwave (6 kV, 200A, 100 kHz)	< 60 V Peak
	Typical Category B Ringwave (6 kV, 500A, 100 kHz)	<100 V Peak UL 1449
Safety	UL 1449 3rd Edition, UL1283, cUL Recognized Component, CE	

Connection Diagram

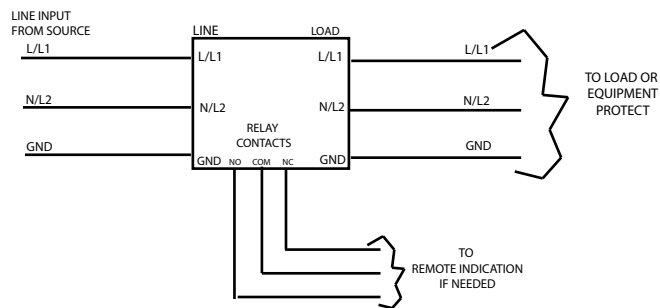

Contact **Technical Services** at **(800) 377-4384** with any questions.
Visit our website at www.solahd.com.

Dimensional Diagram

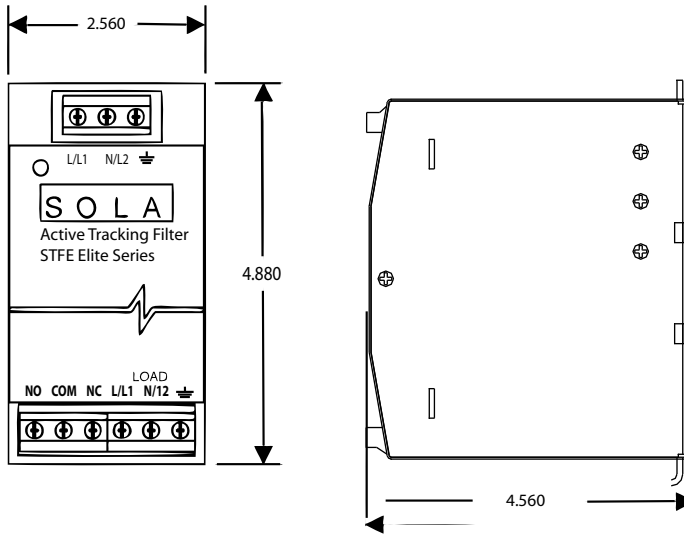

Wiring Specifications

Catalog Number	Amps	Min Wire Size* (AWG Suggested)	Fuse/Circuit Breaker Ampacity	
			Suggest	Max
Single-Phase Models (120 Vac)				
STFE030-10N	3.0	24	3A	3.75A
STFE050-10N	5.0	22	5A	6.25A
STFE100-10N	10.0	20	10A	12.5A
STFE200-10N	20.0	12	20A	25A
Single-Phase Models (240 Vac)				
STFE030-24L	3.0	24	3A	3.75A
STFE050-24L	5.0	22	5A	6.25A
STFE100-24L	10.0	20	10A	12.5A
STFE200-24L	20.0	12	20A	25A

*16 AWG wire or larger may be required by code dependent upon the application.

Internal Diagram

Rear View

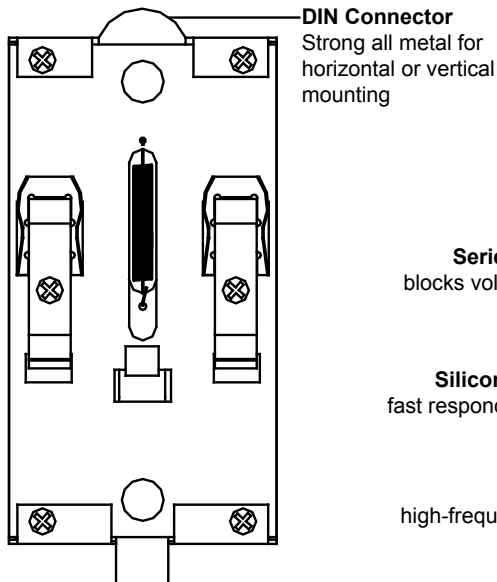

Internal View of Components

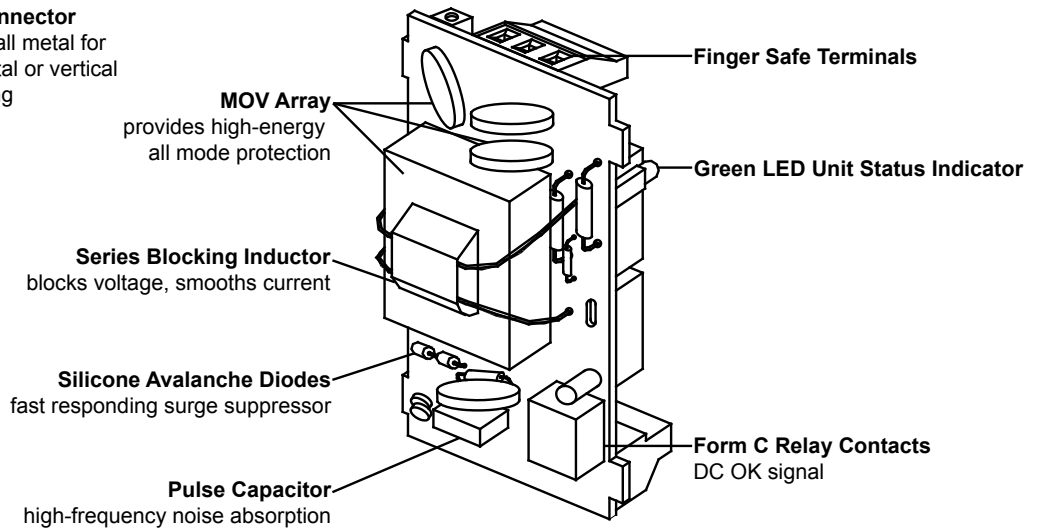

Contact **Technical Services** at (800) 377-4384 with any questions.
Visit our website at www.solahd.com.

STC Series – Data/Signal Line Surge Protection Devices for Transient Data



The rapid development of automated controls, telecommunications and fire/security systems has made it imperative to have properly coordinated low-voltage protection. Modern networked industrial facilities require error free transmission of information for maximum productivity and integrity of data.

The SolahD STC series protects all susceptible low-voltage cable routes entering a facility and at key points within the building. These devices can be used as part of a multi-stage protection strategy which involves clamping the initial high-energy impulse, filtering any remaining noise or transients to the PLC or sensitive equipment and finally, protecting the Data/Signal lines entering and leaving the control panel. Modern, networked industrial facilities require error free transmission of information for maximum productivity and data integrity.

The hybrid design of these Data/Signal Line surge suppressors allows them to respond quickly with high energy absorption. These units are available in a variety of application specific voltage levels and packaging configurations. The STC series is used to protect network signal lines entering or leaving control panels including PLCs, universal remote I/O, DeviceNet™ and Data Highway Plus.



Related Products

- Single and Three Phase Power Conditioners
- Uninterruptible Power System
- Transient Voltage Surge Suppressors
- Active Tracking® Filters
- Power Supplies

Low Voltage - Data/Signal, STC Series

Series	Application
STC-POE	Power-over-Ethernet, Category 5 and Category 6
STC-DRS	DIN Rail mountable, single pair surge protection
STC-642	Two-Pair Data/Signal Protection
STC-CCTV	High-Frequency Coaxial protection for head and camera ends
STC-TEL	RJ11 Telephone Protection

Contact **Technical Services** at **(800) 377-4384** with any questions.
 Visit our website at www.solahd.com.

STC-P0E Series, Category 5 and 6 Power-over-Ethernet Applications

The SolaHD STC Power-over-Ethernet (PoE) series is designed to work on Category 5 PoE transmission lines as well as Category 6 applications. They feature both female to female and male to female RJ-45 connection options for ease of installation.

Power-over-Ethernet is a technology for wired Ethernet LANs (Local Area Networks) that allows the electrical current to be carried by the data cables rather than power cords. This minimizes the number of wires that must be strung in order to install the network. The result is lower cost, less downtime, easier maintenance and greater installation flexibility than with traditional wiring.

POE allows users to power devices over Ethernet cabling. Power and networking is provided over a single cable. PoE has tremendous advantages in industrial applications. The ease of combining signal and power in a single Ethernet cable connection is contributing to the already rapid evolution of Ethernet-based industrial control systems. Category 5e and Category 6 commonly known as Cat5e and Cat6 are the most widely used Ethernet connectivity methods on the market today. Cat5e and Cat6 are defined in ANSI/TIA/EIA 568-B standard for Unshielded Twisted Pair Cabling.



The STC-P0E series is ideally suited to protect expensive equipment and critical communication/data transfer from internally generated transients and noise.

Features

- Exceeds CAT 5 PoE & 6 Transmission Values
- Applications up to 60 Vdc @ 300 mA
- 3 Year Limited Warranty

Specifications

Description	STC-P0E-65FF	STC-P0E-65MF
Mode of Protection	Normal Mode (L-L) All Lines (1-8) Protected	
DC Breakover Voltage	65 Vdc	
Insertion Loss	< .1 dB	
Certified Transmission Speeds	10baseT, 100baseT, 1000baseT	
Peak Surge Energy	300 Watt	
Response Time	<1 ns	
Connectors	RJ-45 (Female — Female)	RJ-45 (Male — Female)
Dimensions - in (mm)	2.3 x 1.0 x .8 (5.84 x 2.54 x 2.032)	3.0 x 1.0 x .8 (7.62 x 2.54 x 2.032)
Warranty	3 years	

Contact **Technical Services** at (800) 377-4384 with any questions.
Visit our website at www.solahd.com.

STC-DRS Series, DIN Rail Protection

Using three-stage hybrid technology, this DIN Rail mountable, single pair, surge suppressor attenuates over-voltage transients with gas tubes and silicon avalanche components while resettable fuses (PTCs) mitigate sneak currents. The PTC increases resistance by several orders of magnitude when over-currents exceed safe levels. A normal state resumes when over-currents are removed. The ability to self-restore in this manner significantly increases suppressor performance and survivability.

The STC-DRS Series mounts onto a standard 35 mm industrial DIN rail. There are three Field Side and three Electronics Side screw terminals. One is reserved for a shield. Three electrically tied ground terminals are provided for grounding the unit to building-approved ground. The shield is isolated from ground.

Features

- Low-Voltage Data Surge Protection
- Three-Stage Hybrid Technology
- Sneak/Fault Current Protection With Resettable Fuses (PTCs)
- Low Profile Packaging
- Easy Installation
- Fits Standard 35 mm DIN Rail
- Fast Response Time <1 Nanosecond
- UL 497B Listed
- 5 Year Limited Warranty



Dimensions

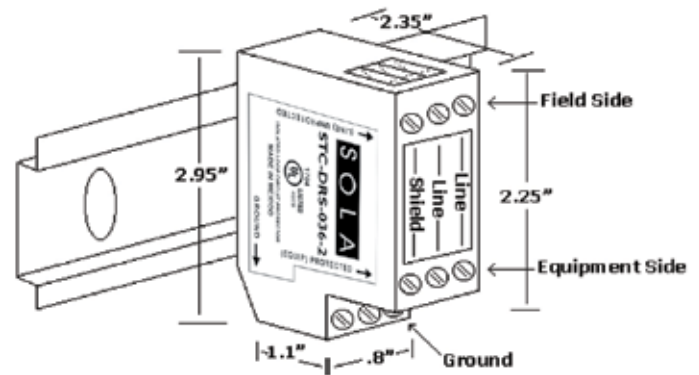

Notes:

These protectors are intended for indoor use on communication loop circuits that have been isolated from the Public Switch Telephone Network.

The communication loop circuits shall not be exposed to accidental contact with the electric light or power conductors. The protectors shall be installed per the applicable requirements of the National Electric Code, ANSI/NFPA 70.

Selection Table

Catalog Number	Max Peak Signal Voltage	Nominal Breakdown Voltage	Max Current 1p 10X1000 ms (Occurrences)	Peak Current 8X20 ms	Typ. Cap (PF)	Max Continuous Current	Nominal Series Resistance
STC-DRS-232	15	22	>100	10KA	1500	150ma	5 Ω
STC-DRS-036	30	36	>100	10KA	1500	150ma	5 Ω
STC-DRS-060	52	60	>100	10KA	1500	150ma	5 Ω

Contact **Technical Services** at (800) 377-4384 with any questions.
Visit our website at www.solahd.com.

STC-642 Series, Data/Signal Line Protection

The STC-642 series of surge suppressors are dual pair (four wire) modules using three-stage hybrid technology. This module addresses over voltage transients with gas tubes and silicon avalanche components. In addition, sneak and fault currents are mitigated with resettable fuses (PTCs). The PTCs increase resistance several orders of magnitude when over currents exceed safe levels. A normal state resumes when over currents are removed. The ability to self restore in this manner significantly increases suppressor performance and survivability.

The STC-642 card edge module is gold-plated, double sided and is designed to mate with the STC-642 gold-plated female terminal connector (sold separately). When snapped together, the data circuits pass thru the protector in a serial fashion from the four Field Side terminals to the four Electronics Side terminals. Terminals 1 or 10 of the STC-PCB1B must be attached to building approved ground.

Features

- Lightning Protection for Low Voltage Data
- Signal Lines
- Three-Stage Protection
- Sneak/Fault Current Protection
- Resettable Solid-State Fuses - PTCs
- Low Capacitance Option for High Speed Data
- Plug-in Module / Requires PCB1B Base
- Fast Response Time
- UL Listed 497B
- 5 Year Limited Warranty

Selection Table

Catalog Number	Description
STC-PCB1B	Base for all STC-642 models. Designed to accommodate up to 10 AWG wire. It offers Flat/Phillips screws and can be mounted using 2 #6 size screws. Must be ordered separately.
STC-FM4-DRC	Optional DIN Rail Mounting Clip for STC-PCB1B



Specifications

Description	STC642-020*	STC642-036*
Peak Surge Current (10 times)	8x20 s .. 10kA 10x700 s 500A per line	
Life Expectancy	8x20 s (2000A) .. >100 occurrences 10x700 s (400A)	
Response Time	<1ns	
Voltage Clamp	20	36
Technology	SAD Hybrid	
Resistance	5 (typical)	
Capacitance (typical)	1500pf	
Operating Temperature	-40°C to +85°C	
Weight	2 oz.	
Dimensions H x W x L (STC-642 & PCB1B)	2.05 x 1.0 x 2.4	
Certifications	UL 497B	
Warranty	5 Years	

*Part number STC-PCB1B sold separately

Contact **Technical Services** at (800) 377-4384 with any questions.
Visit our website at www.solahd.com.

STC-642 Series, Data/Signal Line Protection

Wiring Diagram (PIN Assignments)

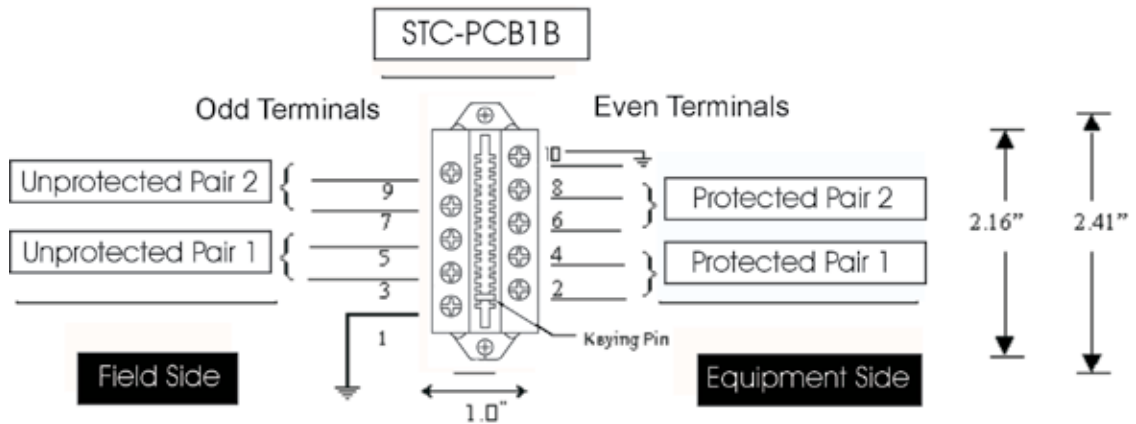

Ground Terminal 1 or 10 (internally tied together) to building approved ground. The STC-PCB1B accommodates 24 to 10 AWG wire.

The hybrid design of this product includes series resistance. Do not place this product in service on any signal line capable of supplying more than 150 milliamperes continuously.

These protectors are intended for indoor use on communication loop circuits which have been isolated from the Public Switch Telephone Network.

The communication loop circuits shall not be exposed to accidental contact with the electric light or power conductors. The protectors shall be installed per the applicable requirements of the National Electric Code, ANSI/NFPA 70.

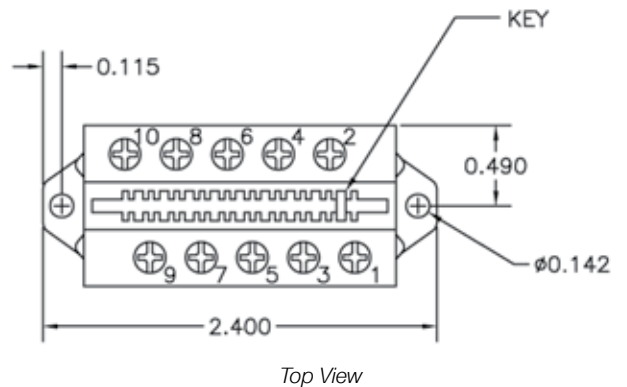

Top View



Side View

Part Numbers by Application

STC642-036 & STC-PCB1B for 4-20 ma Signal

STC642-020 & STC-PCB1B for RS232

STC-CCTV Coax Series



The STC-CCTV Series is tailored specifically to CCTV, data, audio and cable applications. These units are single Coax Surge Protective Devices implementing three-stage hybrid technology. They address overvoltage transients with a primary gas tube, and secondary silicon avalanche components. Over-currents (e.g. sneak and fault currents) are mitigated with solid-state resettable fuses (PTCs). The STC-CCTV units are designed in accordance with NFPA 780 (2004 Edition) requirements, with up to 20kA of surge current capability. The STC-CCTV-75I model has an isolated ground and is recommended for use at the camera end.

Features

- Hybrid, three-stage technology
- Sneak/Fault Current Protection
- Low Insertion Loss
- Shielded Case
- 5 Year Limited Warranty

Application Guide

- CCTV Head End
- CCTV Camera End

Specifications

Description	STC-CCTV-75	STC-CCTV-75I
Operating Voltage	5	
Clamping Voltage	6	
Frequency Range	0 to 20 MHz	
Equipment Location	IEEE Category C, and Category B	
Rated Load Current	0.35 amperes	
Topology	2-port Series	
STC Technology	Primary Stage: Gas Tubes, Secondary Stage: Silicon Avalanche Components Third Stage: resettable fuses (PTCs)	
Modes of Protection	Signal to Ground	
Nominal Discharge Current per Mode	10.0 kA	
Maximum Discharge Current per Mode	20.0 kA	
EMI Attenuation	< 0.1 dB at 20 MHz	
VSWR	< 1.2	
Continuous Power	0.72 Watts	
Operating Humidity	0-95 % Non-condensing	
Operating & Storage Temperature	-40°C to +85°C	
Input & Output Connection Type	BNC, 50 Ohm	
Mounting	Flange	
Enclosure Type	Metal	
Certifications	UL 497B Pending, NFPA 780 (2004) Compliant for Communication Protectors	
Warranty	5 Years	

Contact **Technical Services** at (800) 377-4384 with any questions.
Visit our website at www.solahd.com.

STC-TEL Series – RJ Connection Telephone Protection

The SolaHD STC-TEL series are single pair telephone or Data Line Protectors that use an advanced two-stage hybrid design. These units address over voltage transients with silicon breakover devices, while sneak and fault currents are mitigated with resettable fuses (PTCs).

These units use two screw terminals to connect a Telco line to the protector. The equipment to be protected then plugs into the female modular jack on the STC-TEL.



Features

- <1 Nanosecond Response Time
- Solid State Silicon Breakover Technology
- Low Capacitance
- Over current Protection
- UL 497A Listed
- Line-to-Line, Line-to-Ground Protection
- Resettable Fuses PTCs
- 5 Year Limited Warranty

Applications

- Telephone Lines
- Data Lines

Specifications

Catalog Number	Max Peak Signal Voltage	Nominal Breakdown Voltage	Max Current 1p (10X1000ms) (Occurrences)	Max Clamp* Voltage @1p	Typ. Cap (PF)	Max Continuous Current	Nominal Series Resistance
STC-TEL-200T	220	270	100 (T-G)(R-G)	10	50	150ma	8 Ω

* Forward voltage after breakover.

Installation

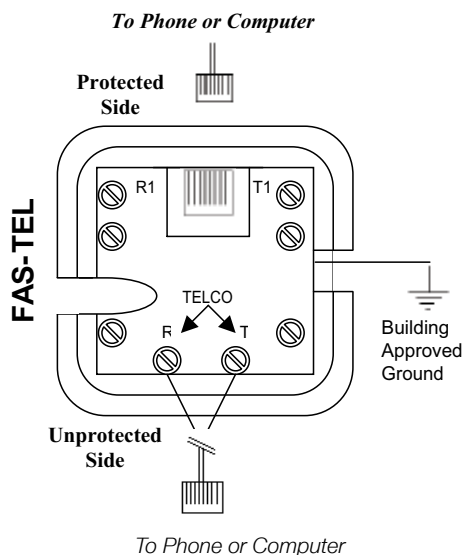

Contact **Technical Services** at (800) 377-4384 with any questions.
Visit our website at www.solahd.com.

CVS Hardwired Series – Constant Voltage Transformers

Superior voltage regulation of $\pm 1\%$ sets the CVS series apart from other power conditioning technologies on the market. Extremely tight regulation is accomplished by SolaHD's patented ferroresonant transformer technology. The CVS recreates a well regulated sinusoidal waveform that is well isolated from input disturbances including:

- Impulses
- Swells
- Brownouts
- Sags
- Severe waveform distortion

No other power conditioning technology provides as complete a solution against these power quality disturbances. The CVS series is ideal for applications where even a small change in voltage level can lead to unscheduled downtime, misoperation, incorrect data or scrapped production.

Features

- Superior voltage regulation of $\pm 1\%$
- Surge protection tested to ANSI/IEEE C62.41, Class A & B Waveform
- Harmonic filtering
- Hardwired
- Acts as a Step-up/Step-down Transformer
- Galvanic isolation provides exceptional circuit protection.
- 25 year typical Mean Time Between Failure
- No maintenance required



Applications

- Industrial automation and control equipment PLCs
- Analytical laboratory and factory automating equipment
- Photo processing equipment
- Sound/recording systems
- Photographic enlargers
- Broadcast equipment

Related Products

- On-line UPS (S4K Industrial)
- Surge Protection
- Three Phase Power Conditioners
- Active Tracking® Filters

Selection Tables: Single Phase

Group 1 – CVS Series, 60 Hz

VA	Catalog Number	Voltage Input	Voltage Output	Height (inch)	Width (inch)	Depth (inch)	Ship Weight (lbs)	Design Style	Elec Conn
30	23-13-030-2	120	120	7	4	5	9	1	J
60	23-13-060-2	120	120	7	4	5	9	1	J
120	23-22-112-2	120, 240	120	8	4	5	13	1	J
250	23-23-125-8	120, 240, 480	120	11	6	8	29	1	G
500	23-23-150-8	120, 208, 240, 480	120, 240	13	9	7	42	1	H
1000	23-23-210-8	120, 208, 240, 480	120, 240	17	9	7	65	1	H
2000	23-23-220-8	120, 208, 240, 480	120, 240	18	13	10	111	1	H
3000	23-23-230-8	120, 208, 240, 480	120, 240	19	13	10	142	1	H
5000	23-23-250-8	120, 208, 240, 480	120, 240	28	13	10	222	1	H
7500*	23-28-275-6	240, 480	120, 240	27	25	9	365	2	J

* This unit is not CSA Certified.

Contact **Technical Services** at (800) 377-4384 with any questions.
Visit our website at www.solahd.com.

Specifications

Parameter	Condition	Value
Input		
Voltage	Continuous at full load (lower input voltage possible at lighter load)	+10% to -20% of nominal
	For temporary surge or sags	+20% to -35% of nominal
Current¹	at Full Load & 80% of nominal input voltage	$I_n \cong (VA/.87)/(V_{in} \times 80\%)$
Frequency	See Operating Characteristics section for details.	60 Hz
Output		
Line Regulation	$V_{in} >80\%$ and $<110\%$ of nominal	$\pm 1\%$
Overload Protection	At Nominal Input Voltage	Current limited at 1.65 times rated current
Output Harmonic Distortion	At Full Load within Input Range	3% total RMS content
Noise Attenuation	-Common Mode	40 dB
	-Transverse Mode	40 dB
General		
Efficiency	At Full Load	Up to 92%
Storage Temperature	Humidity $<95\%$ non-condensing	-20° to 80°C
Operating Temperature	Humidity $<95\%$ non-condensing	-20° to 50°C
Audible Noise	Full Resistive Noise	32 dBA to 65 dBA
Approvals	60 Hz Models	UL1012, CSA ²
Warranty	See General Information section for details	10 Years

Notes:

- 1 - Consult user manual for fuse sizing.
- 2 - Applies to all models except 23-28-275-6.
- 3 - It is recommended that the unit run at a minimum of 40-50% load.
See the Operating Characteristics section of this chapter for more information.

Design Styles (CVS and MCR Hardwired)

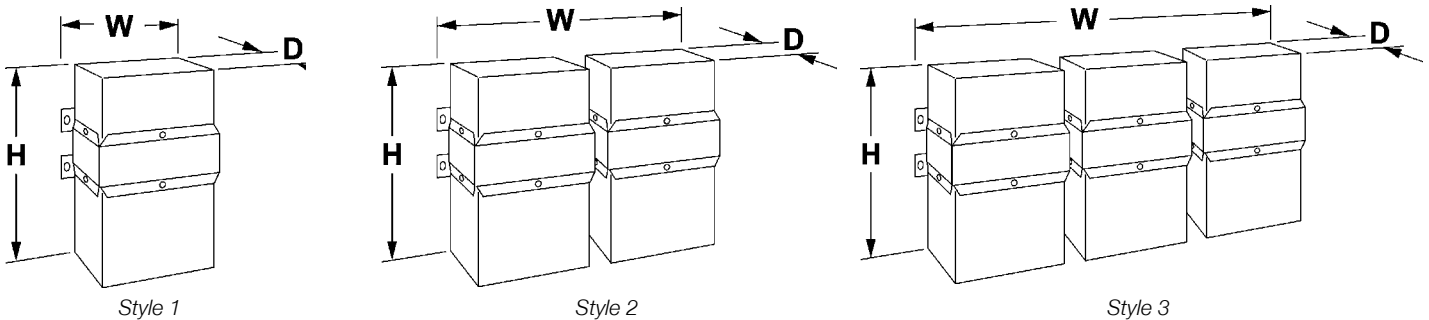

These styles are single phase only.

Contact **Technical Services** at (800) 377-4384 with any questions.
Visit our website at www.solahd.com.

MCR Hardwired Series – Power Line Conditioning with Voltage Regulation

The MCR Hardwired Series provides excellent noise filtering and surge protection to safeguard connected equipment from damage, degradation or misoperation. Combined with the excellent voltage regulation inherent to SolaHD's patented ferroresonant design, the MCR can increase the actual Mean Time Between Failure (MTBF) of protected equipment. The MCR is a perfect choice where dirty power, caused by impulses, swell, sags, brownouts and waveform distortion can lead to costly downtime because of damaged equipment.



Related Products

- On-line UPS (S4K Industrial)
- Surge Protection
- Three Phase Power Conditioners
- Active Tracking® Filters

Selection Tables: Single Phase

Group 2 – MCR Series, 60 Hz Only



VA	Catalog Number	Voltage Input	Voltage Output	Height (inch)	Width (inch)	Depth (inch)	Ship Weight (lbs)	Design Style	Elec Conn
120	63-23-112-4	120, 208, 240, 480	120	9	4	5	15	1	D
250	63-23-125-4	120, 208, 240, 480	120	10	6	8	27	1	D
500	63-23-150-8	120, 208, 240, 480	120, 208, 240	13	9	7	37	1	E
750	63-23-175-8	120, 208, 240, 480	120, 208, 240	14	9	7	52	1	E
1000*	63-23-210-8	120, 208, 240, 480	120, 208, 240	17	9	7	62	1	E
1500*	63-23-215-8	120, 208, 240, 480	120, 208, 240	17	13	9	95	1	E
2000*	63-23-220-8	120, 208, 240, 480	120, 208, 240	18	13	9	109	1	E
3000*	63-23-230-8	120, 208, 240, 480	120, 208, 240	19	13	9	142	1	E
5000*	63-23-250-8	120, 208, 240, 480	120, 208, 240	28	13	9	222	1	E
7500**	63-28-275-8	208, 240, 480	120, 208, 240	27	26	9	362	2	F
10000**	63-28-310-8	208, 240, 480	120, 208, 240	28	26	9	446	2	F
15000**	63-28-315-8	208, 240, 480	120, 208, 240	28	38	10	710	3	F

* Canadian option: cULus certified units must be ordered by changing "-8" (UL only) to "-C8".

** UL Listed Only. Use Group 3 for cULus.

Contact **Technical Services** at (800) 377-4384 with any questions.
Visit our website at www.solahd.com.

Selection Tables: Single Phase

Group 3 – MCR Series, 60 Hz Only



VA	Catalog Number	Voltage Input	Voltage Output	Height (inch)	Width (inch)	Depth (inch)	Ship weight (lbs)	Design Style	Elec Conn
500	63-31-150-8	600	120, 208, 240	13	9	7	38	1	B
1000	63-32-210-8	600	120, 208, 240	17	9	7	62	1	B
2000	63-32-220-8	600	120, 208, 240	18	13	10	109	1	B
3000	63-32-230-8	600	120, 208, 240	19	13	10	142	1	B
5000	63-29-250-8	208, 240, 480, 600	120, 208, 240	28	13	10	221	1	A
7500	63-29-275-8	208, 240, 480, 600	120, 208, 240	27	25	10	360	2	A
10000	63-29-310-8	208, 240, 480, 600	120, 208, 240	28	25	10	441	2	A
15000	63-29-315-8	208, 240, 480, 600	120, 208, 240	28	38	10	706	3	A

Group 4 – MCR Series, 50 Hz Only (±5% output voltage regulation)



VA	Catalog Number	Voltage Input	Voltage Output	Height (inch)	Width (inch)	Depth (inch)	Ship weight (lbs)	Design Style	Elec Conn
120	63-23-612-8	110, 120, 220, 240, 380, 415	110, 120, 220, 240	9	6	8	24	1	C
250	63-23-625-8	110, 120, 220, 240, 380, 415	110, 120, 220, 240	11	6	8	27	1	C
500	63-23-650-8	110, 120, 220, 240, 380, 415	110, 120, 220, 240	13	9	7	40	1	C
1000	63-23-710-8	110, 120, 220, 240, 380, 415	110, 120, 220, 240	18	9	7	64	1	C
2000	63-23-720-8	110, 120, 220, 240, 380, 415	110, 120, 220, 240	18	13	10	113	1	C
3000	63-23-730-8	110, 120, 220, 240, 380, 415	110, 120, 220, 240	27	13	10	162	1	C
5000	63-23-750-8	110, 120, 220, 240, 380, 415	110, 120, 220, 240	30	13	10	266	1	C
7500	63-28-775-8	220, 240, 380, 415	110, 120, 220, 240	28	26	10	393	2	C1
10000	63-28-810-8	220, 240, 380, 415	110, 120, 220, 240	30	26	10	490	2	C2
15000	63-28-815-8	220, 240, 380, 415	110, 120, 220, 240	30	38	10	776	3	C2

Specifications

Parameter	Condition	Value
Input		
Voltage	Continuous at full load (lower input voltage possible at lighter load)	+10% to -20% of nominal
	For temporary surge or sags	+20% to -35% of nominal
Current¹	at Full Load & 80% of nominal input voltage	$I_{in} \cong (VA/.89)/(V_{in} \times 80\%)$
Frequency	See Operating Characteristics section for details.	50 Hz or 60 Hz depending on model
Output		
Line Regulation	$V_{in} >80\%$ and $<110\%$ of nominal	± 5% for 50 Hz units, ± 3% for 60 Hz units
Overload Protection	At Nominal Input Voltage	Current limited at 1.65 times rated current
Output Harmonic Distortion	At full load within input range	3% total RMS content
Noise Attenuation	Common Mode	120 dB
	Transverse Mode	60 dB
General		
Efficiency	At Full Load	Up to 92%
Storage Temperature	Humidity <95% non-condensing	-20° to +85°C
Operating Temperature	Humidity <95% non-condensing	-20° to 50°C
Audible Noise	Full Resistive Noise	35 dBA to 65 dBA
Approvals	60 Hz Models	UL1012, CSA evaluated by UL
	50 Hz Models	CE (EMC & LVD)
Warranty	See General Information section for details	10 + 2 Years

Notes: 1 - Consult user manual for fuse sizing.
 2 - It is recommended that the unit run at a minimum of 40-50% load.

Contact **Technical Services** at (800) 377-4384 with any questions.
 Visit our website at www.solahd.com.

Electrical Connections

A

Primary Voltage	Interconnect	Connect Lines To
208	H1 to H4 H2 to H5	H1 & H5
240	H1 to H4 H3 to H6	H1 & H6
480	H3 to H4	H1 & H6
600	H3 to H4	H1 & H7
Secondary Voltage	Interconnect	Connect Lines To
120		X1 & X2 or X3 & X2
208		X4 & X5
240		X1 & X3

MCR 60 Hz 5000–15000 VA

B

475–650 V

Primary Voltage	Interconnect	Connect Lines To
600		H1 & H2
Secondary Voltage	Interconnect	Connect Lines To
120		X1 & X2 or X3 & X2
208		X4 & X5
240		X1 & X3

MCR 60 Hz 500–3000 VA

C

Primary Voltage	Interconnect	Connect Lines To
110-120	H1 to H3 H2 to H4	H1 & H4
220-240	H2 to H3	H1 & H4
380-415	H2 to H3	H1 & H5
Secondary Voltage	Interconnect	Connect Lines To
110		X1 & X2 or X3 & X2
120		X4 & X2 or X5 & X2
220		X1 & X3
240		X4 & X5

MCR 50 Hz 120–5000 VA

C1

Primary Voltage	Interconnect	Connect Lines To
220-240	H1 to H3 H2 to H5	H1 & H5
380-415	H2 to H3	H1 & H4
Secondary Voltage	Interconnect	Connect Lines To
110		X1 & X2 or X2 & X3
120		X4 & X2 or X5 & X2
220		X1 & X3
240		X4 & X5

MCR 50 Hz 7500 VA

C2

Primary Voltage	Interconnect	Connect Lines To
220-240	H2 to H3	H1 & H4
380-415	H2 to H3	H1 & H5
Secondary Voltage	Interconnect	Connect Lines To
110		X1 & X2 or X3 & X2
120		X4 & X2 or X5 & X2
220		X1 & X3
240		X4 & X5

MCR 50 Hz 10000–15000 VA

D

H5 380–520V
H4 190–260V
H3 175–235V
H2 95–130V
H1 Common

Primary Voltage	Interconnect	Connect Lines To
120		H1 & H2
208		H1 & H3
240		H1 & H4
480		H1 & H5
Secondary Voltage	Interconnect	Connect Lines To
120		X1 & X2

MCR 60 Hz 120–250 VA

Contact **Technical Services** at (800) 377-4384 with any questions.
Visit our website at www.solahd.com.

Electrical Connections

Primary Voltage	Interconnect	Connect Lines To
120		H1 & H2
208		H1 & H3
240		H1 & H4
480		H1 & H5
Secondary Voltage	Interconnect	Connect Lines To
120		X1 & X2 or X3 & X2
208		X4 & X5
240		X1 & X3

MCR 60 Hz 500-5000 VA

Primary Voltage	Interconnect	Connect Lines To
208		H2 & H3
240		H2 & H4
480		H1 & H4
Secondary Voltage	Interconnect	Connect Lines To
120		X1 & X2 or X3 & X2
208		X4 & X5
240		X1 & X3

MCR 60 Hz 7500, 10000 and 15000 VA

Primary Voltage	Interconnect	Connect Lines To
120	H1 to H3 to H5 to H7 H2 to H4 to H6 to H8	H1 & H2
240	H2 to H3 H6 to H7 H1 to H5 H4 to H8	H1 & H4
480	H2 to H3 H4 to H5 H6 to H7	H1 & H8
Secondary Voltage	Interconnect	Connect Lines To
120		X1 & X2

CVS 60 Hz 250 VA only

Primary Voltage	Interconnect	Connect Lines To
120	H1 to H3 to H6 to H8 H2 to H5 to H7 to H10	H1 & H2
208	H2 to H3 H7 to H8 H1 to H6 H4 to H9	H1 & H4
240	H2 to H3 H7 to H8 H1 to H6 H5 to H10	H1 & H5
480	H2 to H3 H5 to H6 H7 to H8	H1 & H10
Secondary Voltage	Interconnect	Connect Lines To
120		X1 & X2 or X3 & X2
240		X1 & X3

CVS 60 Hz 500-5000 VA

Series-Multiple Primary with Tap for two input voltages J

30 & 60 VA Primary Voltage	120 VA Primary Voltage	7500 VA Primary Voltage	Interconnect	Connect Lines To
120	N/A	N/A	Note: H3 & H4 are not used	H1 & H2
N/A	120	240	H1 to H3 H2 to H4	H1 & H4
N/A	240	480	H2 to H3	H1 & H4
30 & 60 VA Secondary Voltage	120 VA Secondary Voltage	7500 VA Secondary Voltage	Interconnect	Connect Lines To
120	120	N/A		X1 & X2
N/A	N/A	120		X1 & X2 or X3 & X2
N/A	N/A	240		X1 & X3

CVS 60 Hz 30-120 VA & 7500 VA

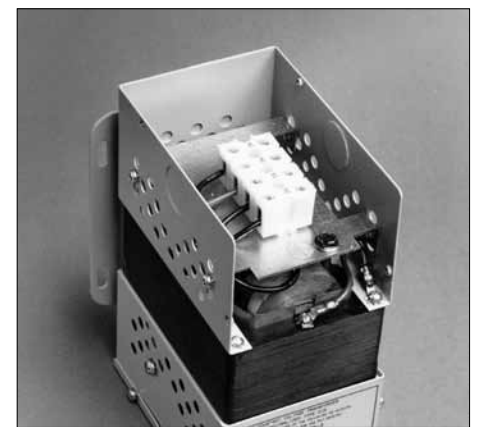

Open MCR/ CVS terminal

Note:
Secondaries are not grounded.
Ground X₂ per Code.

MCR Portable Series – Power Line Conditioning with Voltage Regulation

The MCR provides excellent noise filtering and surge protection to protect connected equipment from damage, degradation or misoperation. Combined with the excellent voltage regulation inherent to SolaHD's patented ferroresonant design, they can increase the actual Mean Time Between Failure (MTBF) of protected equipment. These units are a perfect choice where dirty power caused by impulses, swell, sags, brownouts and waveform distortion can lead to costly downtime because of damaged equipment.



MCR Portable Series



Applications

- Computers/ Printers
- POS terminals
- Laboratory equipment
- Telephone/FAX systems
- Security systems
- LAN networks

Features

- $\pm 3\%$ output voltage regulation
- Noise attenuation
 - 120 dB common mode
 - 60 dB transverse mode
- Surge protection tested to ANSI/IEEE C62.41 Class A & B Waveform (<10 V let-through typical)
- Harmonic filtering
- Galvanic isolation provides exceptional circuit protection.
- Point-of-use Protection (cord & plug connected)
 - Easy & Flexible Installation
- 25 year typical MTBF
- No maintenance required

Related Products

- DIN Rail AC UPS (SDU)
- Off-Line UPS (S1K Mini-Tower)
- Line-Interactive UPS (S3K Mini-Tower)

Specifications

Parameter	Condition	Value
Input		
Voltage	Continuous at full load (lower input voltage possible at lighter load)	+10% to -20% of nominal
	For temporary surge or sags	+20% to -35% of nominal
Current	At Full Load & 80% of nominal input voltage	$I_m \cong (VA/.89)/(V_{in} \times 80\%)$
Frequency	See Operating Characteristics section for details.	60 Hz depending on model
Output		
Line Regulation	$V_m > 80\%$ and $< 110\%$ of nominal	$\pm 3\%$ for 60 Hz units
Overload Protection	At Nominal Input Voltage	Current limited at 1.65 times rated current
Output Harmonic Distortion	At full load within input range	3% total RMS content
Noise Attenuation	-Common Mode	120 dB
	-Transverse Mode	60 dB
Let-Through	ANSI/IEEE C62.41 Class A & B Waveform	<10V typical
General		
Efficiency	At Full Load	92% Typical
Storage Temperature	Humidity <95% non-condensing	-20° to +85°C
Operating Temperature	Humidity <95% non-condensing	-20° to 40°C
Audible Noise	Full Resistive Noise	35 dBA to 65 dBA
Approvals	60 Hz Models	UL1012 ¹ , CSA (or cUL) ¹
Warranty	See General Information section for details	10 + 2 Years

Notes: 1 - Depending on model, see selection tables to confirm agency approvals for specific model numbers.

Contact **Technical Services** at (800) 377-4384 with any questions.
Visit our website at www.solahd.com.

Selection Tables: Single Phase

Group A – MCR Portable Series, 60 Hz Only

VA	Catalog Number	Voltage Input/Output	Height (inch)	Width (inch)	Depth (inch)	Ship Weight (lbs)	Receptacle (No.) Type (NEMA)	Plug (NEMA)
70	63-13-070-6	120	6	7	9	18	(4) 5-15R	5-15P
150	63-13-115-6	120	6	7	9	21	(4) 5-15R	5-15P
250	63-13-125-6	120	6	7	9	26	(4) 5-15R	5-15P
500	63-13-150-6	120	9	9	16	32	(4) 5-15R	5-15P
750	63-13-175-6	120	9	9	16	64	(4) 5-15R	5-15P
1000	63-13-210-6	120	9	9	16	69	(4) 5-15R	5-15P
1500*	63-13-215-6	120	11	11	17	95	(6) 5-15R	5-20P
2000**	63-13-220-6	120	11	11	17	115	(4) 5-15R, (1) L5-30R	L5-30P
3000**	63-13-230-6	120	11	11	17	143	(4) 5-15R, (1) L5-30R	5-50P

* This unit is cUL_{us} certified.

** This unit is not CSA certified.

Back Panels



60 Hz, 70 – 1000 VA,
(4) 5-15R Receptacles



60 Hz, 2000–3000 VA,
(4) 5-15R and (1)
L5-30R Receptacle

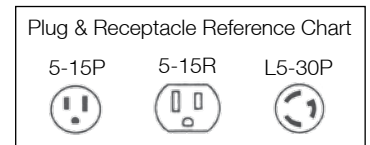

Contact **Technical Services** at (800) 377-4384 with any questions.
Visit our website at www.solahd.com.

Model Comparison

Description	Hardwired CVS	Hardwired MCR	Portable MCR
VA Ratings	30 to 7500 VA	120 to 15000 VA	70 to 3000 VA
Input Voltage Range	+10/-20% of nominal		
Voltage Regulation	±1% for an input line variation of +10/-20%. No loss of output for line loss of 3 msec.	±3% for an input line variation of +10/-20% (50 Hz hardwired units ±5%). No loss of output for complete line loss of 3 msec.	
Overload	Limits output current to 1.65 x rated current at nominal input.		
Output Harmonic Distortion	3% total RMS content at full load.		
Noise Isolation	40 dB common and normal code.	120 dB common mode and 60 dB normal mode.	
Surge Protection	Up to 6000 Volt surges are suppressed to a let through of less than 1% per ANSI/IEEE C62.41 Class A & B waveforms.	ANSI/IEEE C62.41 Class A & B 6000 waveforms are suppressed to a let-through of less than 0.2%.	
Efficiency	Up to 92% at full load		Up to 90% at full load
Operating Temperature	-20°C to 50°C		-20°C to 40°C
Audible Noise	32 dB to 65 dB	35 dB to 65 dB	34 dB to 49 dB
Conformance	Listed to UL 1012. CSA Certified	UL Listed and CSA Certified. 50 Hz models in compliance with Low Voltage Directive Specification EN60950.	Listed to UL 1012. CSA Certified on all models except 3000 VA.
Warranty	10 years		

Note: All values are typical and may vary based on VA ratings of actual units.

BTU Output Chart for CVS and MCR Series

VA Ratings	120	250	500	750	1000	1500	2000	3000	5000	7500	10000	15000
Total BTU's	136	225	280	444	519	686	1229	1331	2117	2407	3209	4813

Note: Ratings are for a 40°C ambient temperature.

Contact **Technical Services** at (800) 377-4384 with any questions.
Visit our website at www.solahd.com.

Operating Characteristics of the CVS & MCR Series

Regulation

SolaHD's CVS power conditioners will hold output voltages to $\pm 1.0\%$ or less with input variations as great as $\pm 15\%$ ($115V \pm 15\%$ or $120V +10\%/-20\%$). Units operated at less than rated load will maintain approximately $\pm 1\%$ regulation over a wider input line voltage variation. Output meets NEMA voltage specifications even when input voltage drops to 65% of nominal. The output versus input voltage relationship for a typical CVS is show in Figure A.

CVS Conditioner Rating – VA	Increase in Output Voltage due to Load Removal
30	3%
60 & 120	2%
250 & over	1%

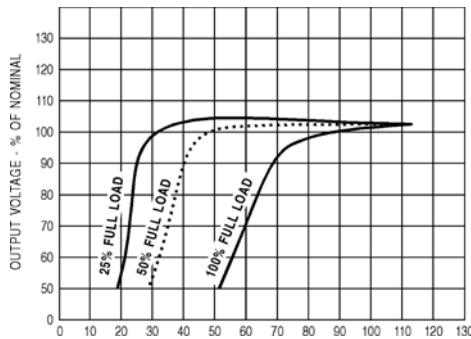

Figure A: Load Variation

Note: MCR line regulations: $\pm 3\%$ for 60 Hz; $\pm 5\%$ for 50 Hz. The typical performances shown in Figure B indicate that most of the residual changes take place near the lower (95 V) and upper (130 V) ends of the input range. It is possible to improve output regulation if line variations remain within a restricted range near the center of the nameplate range (for example, 100-120 V).

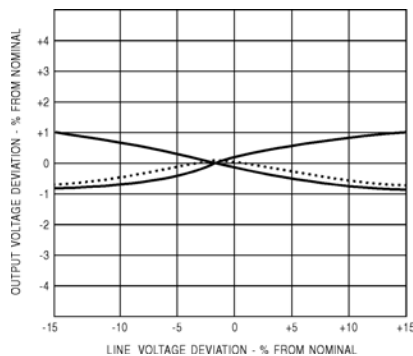

Figure B: Line Regulation

Normally, the output voltage will rise as the load is decreased. Typical percentages for changes in resistive load from full to zero load as shown below.

Except as noted, all characteristics of Sola/HD's CVS products also apply to the MCR series.

Input Characteristics

SolaHD power conditioners include a resonant circuit that is energized whether or not it is serving load. The input current at no load or light load may run 50% or more of the full primary current. As a result, the temperature of the unit may rise to substantially full-load level, even at light or no load. Input power factor will average 90-100% at full load, but may drop to about 75% at half load and 25% at no load. In any case, the current is always leading. The input no load watts are about 12.5% of the VA rating.

Frequency

Output voltage varies linearly with a change of frequency of the input voltage. This change is about 1.5% of the output voltage for each 1% change in input frequency and in the same direction as the frequency change.

Power Factor

SolaHD power conditioners regulate any power factor load. Output voltage is a function of load current and load power factor (see Figure C). If lower voltage under lagging power factor is objectionable, correction may be made with capacitors at the load. "Median" value of output voltage will vary from the nameplate rating if the load has a power factor other than that for which the transformer was designed. Load regulation will also be relatively greater as the inductive load power factor is decreased (see Figure C). However, the resulting median values of output voltage will be regulated against supply line changes at any reasonable load or load power factor.

Operating Characteristics of the CVS & MCR Series

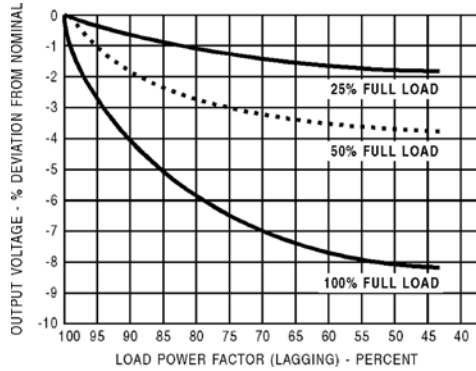

Figure C: Power Factor

Efficiency

The copper magnet wire and lamination material used in SolaHD ferroresonant products are selected to achieve efficiencies of 90% or higher. Whether or not an external load is being served, current will be drawn from the line whenever the primary is energized, since the capacitor remains connected in the circuit.

Overload and Short Circuits

When the load is increased beyond the regulator's rated value, a point is reached where the output voltage suddenly collapses and will not regain its normal value until the load is partially released. Under direct short circuit, the load current is limited to approximately 150-200% of the rated full load value and the input watts to less than 10% of normal.

A constant voltage regulator will protect both itself and its load against damage from excessive fault currents. Fusing of load currents may not be necessary. The actual value of short-circuit current varies with the specific design and rating. Units may be operated indefinitely at short-circuit. This characteristic protects the unit itself as well as the load and load circuit being served. Typical overload performance is shown in Figure D.

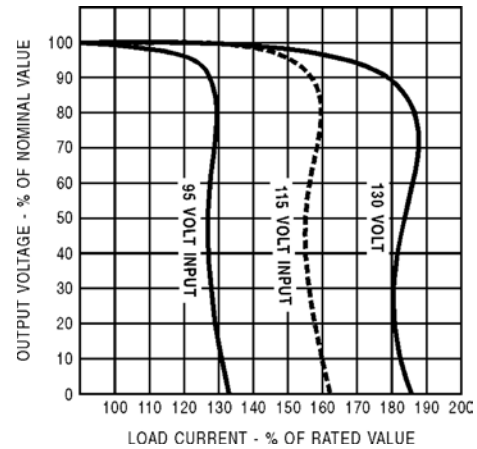

Figure D: Overload Performance

Motor Loads

Because of the fast response time of the SolaHD circuit, any current-limiting characteristic must be taken into account for transient overloads such as motor starting and solenoid operation. In general, the SolaHD constant voltage regulator must have a capacity nearly equal to the maximum demand made on it, even for an instant. To determine the power rating of the regulator, peak motor-starting current or solenoid inrush current should be measured or power factor correcting capacitors should be used to reduce the starting VA of the load.

Response Time

An important advantage of SolaHD's ferroresonant transformer is its fast response time compared with other types of AC regulators. Transient changes in supply voltage are usually corrected within 1½ cycles or less; the output voltage will not fluctuate more than a few percent, even during this interval.

Operating Characteristics of the CVS & MCR Series

Temperature

SolaHD's ferroresonant power conditioners are very stable with respect to temperature. The change in output voltage is only 0.025%/°C. Units are factory adjusted to +2%/-0% of nominal, with full load and nominal input voltage. This adjustment to the high side of nominal is to compensate for the natural temperature drift of about 1% that takes place during initial turn-on or warm-up. When the unit warms up to operating temperature, the voltage typically falls about 1%.

At a stable operating temperature, the output voltage will change slightly with varying ambient temperatures. This shift is equal to approximately 1% for each 40°C of temperature change. The normal maximum temperature rise of a SolaHD power conditioner may fall anywhere in the range of 40°C to 110°C depending on the type and rating. The nominal design ambient range is between -20°C and +50°C (-20°C to +40°C for 70 - 1000 VA, 60 Hz portable models).

External Magnetic Field

In almost all applications, this effect may be disregarded. The exclusive SolaHD "wide outside leg" construction (U.S. Patent 2,806,199) reduces stray magnetic fields to a practical minimum. On critical applications, care should be taken in orientation of the core with respect to critical circuits to minimize the effect of the field.

Phase Shift

The phase difference which exists between input and output voltages is in the range of 120 degrees to 140 degrees at full load. This phase difference varies with the magnitude and power factor of the load, and to a lesser extent, with changes in line voltage and load power factor.

Transient Protection

Ferroresonant power conditioners protect input transients (caused by lightning and load switching) from damaging the sensitive electronic load. A typical surge protective device (SPD) tries to 'clamp' a transient by diverting it to ground. A ferroresonant power conditioner "blocks" the transient. This 'blocking' action is achieved by total physical separation from input (primary) to output (secondary). Because of this difference in operation, it is difficult to apply the same specifications to a ferroresonant power conditioner. Some parallels can be made however.

One, is that under load, the let-through voltage of a ferroresonant power conditioner (SPD refers to "clamping voltage") is less than 10 V above the point where the sine wave would normally be at any given time. The ferroresonant power conditioner is an 'active tracking' suppressor with several advantages. The Ferro power conditioner will not shunt the transient to the ground line as SPD devices typically do. Shunting the transient to ground can cause the disturbance to be transmitted to other sensitive loads within a facility. This can pose serious problems with electronic or microprocessor-based equipment, especially if there is poor grounding within a facility. Other advantages provided by ferroresonant power conditioners include noise filtering, filtering of harmonic distortion and protection against voltage fluctuations such as sags or swells. These features are not provided by standard surge protection devices but are often misrepresented or misused by SPD manufacturers trying to market their product as a "Do All" power quality device.

SOLATRON™ Plus Series - Three Phase Power Conditioners

Features

- Rugged, industrial design
- High overload capability
- High MTBF - No fans used
- No power factor restriction on loads
- Tight regulation for protection against sag (-25%) and swell (+15%) conditions
- Fail-safe, no-break, auto-bypass
- Status indicating lights
- Shielded, copper wound isolation transformer
- Surge protection to ANSI/IEEE and IEC Standards
- High efficiency (96%) microprocessor controlled tap switcher
- Automatic under voltage protection
- UL1012, UL1449-2, cUL_{US} Listed
- Two Year Limited Warranty

Related Products

- STV 100K
- Isolation Transformers

Applications

- Automatic Packaging Machinery
- Large Machine Tool Equipment
- UPS Bypass Circuits
- Retail Store
- Process Equipment

Electrical Specifications

Power Ratings	20, 30, 50, 75 kVA, Three Phase*
Nominal Voltages	See Selection Table
Input Voltage Range	-25% to +15% of nominal rated voltage
Output Voltage Range	Regulated to a max of $\pm 5\%$ (3% typical) of nominal voltage with an input voltage range of -25% to +15%.
Response Time	Responds to any line variation in <1.5 cycles typical.
Technology	Enhance Voltage Regulation (EVR), Microprocessor controlled electronic tap switching. 6 taps switched at zero current crossing with no output interruption.
Operating Frequency	57-63 Hz
Load Power Factor	No Restriction
Insulation Resistance	100 megohms from winding to core measured at 500 Vdc
Efficiency	96% typical
Overload Capability	1000% of rated load for 1 second 200% of rated load for 1 minute
EMI	Less than 0.2 gauss at a distance of 3 ft.

* Contact Technical Services for other ratings.



Mechanical Specifications

Indicators	Indicating Lamps: 2 amber (over temperature and bypass mode), 1 green (regulated output present)			
Connections	Field wired, terminal blocks			
Size		H	W	D
	in	42	28	26
	mm	1016	712	661
Safety Agency Approvals	UL1012 and UL1449-2 cUL (Canadian Standard C22.2 No 125) Complies with Part 15 Subpart J of FCC rules for a Class A computing device.			

Environmental Specifications

Audible Noise	Less than 50 dBA at 3 feet
Ambient Temperature	0° to 40°C Operating, 0° to 80°C Storage
Operating Altitude	10,000 feet without derating
Operating Humidity	95% relative (non-condensing)

Design Style

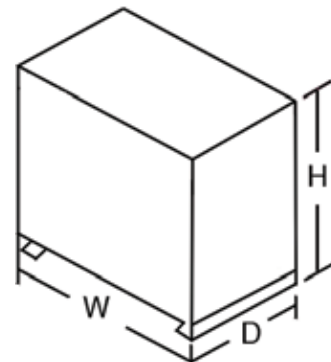

Contact **Technical Services** at (800) 377-4384 with any questions.
Visit our website at www.solahd.com.

Protection Specifications

Under Voltage	Output voltage will switch to bypass mode when input is less than 50% of nominal. Regulated output voltage will be re-established once input voltage is with specifications.
Short Circuit Protection	Input circuit breaker
Over Temperature Protection	Amber lamp indication of over temperature at approximately 180°C. Unit switches to by-pass mode until internal temperature is reduced to specified values.

Noise Suppression Performance Specifications

Common Mode Noise Attenuation	150 dB at 100 kHz
Normal Mode Noise Attenuation	65 dB at 100 kHz
Surge Protection	Tested to ANSI/IEEE standard C62.41 A&B

Selection Table

Output kVA	Catalog Number	Vac Input	Vac Output	Ship Weight (lbs/kg)
208 Vac Input, 208Y/120 Vac Output, 60 Hz				
20	63TAA320	208	208Y/120	600/273
30	63TAA330	208	208Y/120	750/341
50	63TAA350	208	208Y/120	950/432
75	63TAA375	208	208Y/120	1200/545
480 Vac Input, 208Y/120 Vac Output, 60 Hz				
20	63TCA320	480	208Y/120	600/273
30	63TCA330	480	208Y/120	750/341
50	63TCA350	480	208Y/120	950/432
75	63TCA375	480	208Y/120	1200/545
480 Vac Input, 480Y/277 Vac Output, 60 Hz				
20	63TCC320	480	480Y/277	600/273
30	63TCC330	480	480Y/277	750/341
50	63TCC350	480	480Y/277	950/432
75	63TCC375	480	480Y/277	1200/545
600 Vac Input, 208Y/120 Vac Output, 60 Hz				
20	63TDA320	600	208Y/120	600/273
30	63TDA330	600	208Y/120	750/341
50	63TDA350	600	208Y/120	950/432
75	63TDA375	600	208Y/120	1200/545
Custom Voltages	240 Vac Input, 240Y/139 Vac Output, 60 Hz 480 Vac Input, 240Y/139 Vac Output, 60 Hz 600 Vac Input, 240Y/139 Vac Output, 60 Hz			
Contact Technical Services for custom voltages.				

Contact **Technical Services** at **(800) 377-4384** with any questions.
 Visit our website at www.solahd.com.

Contact **Technical Services** at **(800) 377-4384** with any questions.
Visit our website at www.solahd.com.