

MAIN OFFICE
INTERNATIONAL TOOL MANUFACTURING
71-08 51ST. AVENUE, WOODSIDE, NY 11377
(718) 446-0711 - (800) 247-5696 - FAX (718) 899-6553



INTERNATIONAL TOOL MANUFACTURING
675-E-PROGRESS CENTER AVE., LAWRENCEVILLE, GA 30043
(770) 962-5454 - (800) 229-1776 - FAX (770) 962-5869

Dear  **ITM** Customer:

In 1987 ITM incorporated and assembled a team of experts who spent a lifetime in the production and distribution of drilling, cutting, and fastening products. Our goal: to be your best source for professional industrial products that satisfy all construction requirements.

27 years later, our promise to you remains the same: excellence in product, service, and delivery.

We know you have many choices for your drilling and cutting products, but no one tries harder to be sure you get the best industrial quality products available quickly and error free. ITM supplies many of America's most respected and best known distributors and name brands, 27 years strong!

Our commitment remains the same:

- **Fast Delivery** Two stock locations. 99% of all orders are shipped the same day if received before 3 P.M., Eastern Time.
- **Complete Satisfaction** Simple: all of your purchases must satisfy you completely, or we will issue you a refund, exchange, or credit.
- **Easy Ordering** Order Toll Free, by Fax, or email, either by part number or description. Our staff will quickly help you decide which product best fits your application. Order what you need, there is never a minimum order.

In this **NEW 2014** catalog, you will find ordering ITM products as easy as ever: each product line thought through and evaluated; items positioned in a progressive and logical order; pictures clearer; lots of relevant information added to help you choose more confidently. ITM catalogs are always made with **YOU** in mind.

Anytime I can be of help to you, just let me know.
You are very important to all of us.

Thank you for your business and patronage.

Sincerely yours,

Berardo Paradiso
President - ITM Corp.





BLACK
Oxide

- p.10 Two Tone Jobbers HSS 118° Point
- p.10 Brite Finish Jobbers HSS 118° Point
- p.11 Black Oxide Jobbers HSS 118° Point
- p.11 Black Oxide Wire Gauge HSS 118° Point
- p.12 Black Oxide Jobbers HSS 135° Split Point
- p.12 Black Oxide Wire Gauge HSS 135° Split Point
- p.13 Black Oxide Letter HSS 135° Split Point
- p.13 Black Oxide Metric HSS 118° Point
- p.14 Black Oxide Stub Length HSS 135° Split Point
- p.15 Black Oxide Silver & Deming HSS 118° Point



Black & Gold

- p.17 Black & Gold Jobbers HSS 135° Split Point
- p.17 Black & Gold Wire Gauge HSS 135° Split Point
- p.18 Black & Gold Mechanics Length HSS 135° Split Point
- p.19 Black & Gold Letter Size HSS 135° Split Point
- p.19 Black & Gold Silver & Deming HSS 118° Split Point



Cobalt

- p.20 Cobalt Jobbers 135° Split Point
- p.20 Cobalt Wire Gauge 135° Split Point
- p.21 Cobalt Stub Length 135° Split Point
- p.21 Cobalt Silver & Deming 135° Split Point



- p.22 Titanium (TiN) Jobbers HSS 135° Split Point
- p.22 Spotweld Double End Drills
- p.22 Double End Drills 135° Split Point
- p.23 Aircraft HSS 135° Split Point (6" & 12" Long)

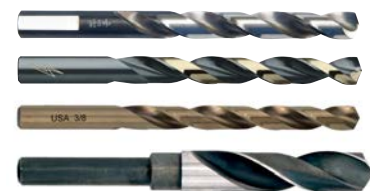

Made In 

- p.24 X6-Chrome Jobbers 135° Split Point
- p.25 Parabolic Jobbers 135° Split Point
- p.25 Cobalt Jobbers 135° Split Point
- p.26 American Original Silver & Deming 135° Split Point



- p.27 Bullet Case Drill Bit Sets























- p.28+ Metal Drill Bit Sets / Dispenser

MAIN OFFICE
 INTERNATIONAL TOOL MANUFACTURING
 71-08 51ST. AVENUE, WOODSIDE, NY 11377
 (718) 446-0711 - (800) 247-5696 - FAX (718) 899-6553



INTERNATIONAL TOOL MANUFACTURING
 675-E-PROGRESS CENTER AVE., LAWRENCEVILLE, GA 30043
 (770) 962-5454 - (800) 229-1776 - FAX (770) 962-5869

Tap & Drill Sets	p.30	
Taps, Carbon Steel	p.34	
Taps, HSS	p.35	
Taps, NP	p.36	
Combo Drill Taps	p.37	
Spiral Point (Gun) Taps	p.37	
Hand Tap Wrenches	p.37	
Counter Sinks	p.38	
Screw Extractors	p.38	
Burs - Solid Carbide	p.39	
Step Drills HSS	p.40	
Reamers	p.41+	
Annular Cutters HSS	p.44	
T.C.T. Annular Cutters	p.45	
T.C.T. Cutters	p.46	
Composite Cutters	p.47	
Bell Hanger Drills (Fish Hole Drills) HSS & Carbide Tipped	p.48	
Electrician's Stretch Bits (Fish Bits)	p.49	
Long Boy Drills HSS (12" & 18" Long)	p.50	
Screw Pilots	p.51	
Plug Cutters	p.51	
Brad Point Wood Drills	p.51	

MAIN OFFICE
 INTERNATIONAL TOOL MANUFACTURING
 71-08 51ST. AVENUE, WOODSIDE, NY 11377
 (718) 446-0711 - (800) 247-5696 - FAX (718) 899-6553



INTERNATIONAL TOOL MANUFACTURING
 675-E-PROGRESS CENTER AVE., LAWRENCEVILLE, GA 30043
 (770) 962-5454 - (800) 229-1776 - FAX (770) 962-5869



p.52 Spade Drills



p.53 Single Spur / Double Spur Wood Drills



p.54 Power Pole Auger Drills



p.55 Ship Auger Wood Drills (8" & 18" Long)



p.56 Forstner Wood Drills



p.57 Self Feed (Multi Spur) Wood Drills



p.57 Extensions (For Ship Augers / Multispur)

p.58 Circular Saw Blades - Wood



p.59 Wire Brushes



p.60 Hole Saws - Bi-Metal

p.61 Hole Saws Kits



p.62 Hole Saws - Carbide Tipped

p.63 Hole Saws - Carbide Grit



p.64 Pilot Drills & Accessories

p.65 Arbors



p.66 Reciprocating Blades - Bi-Metal

p.67 Reciprocating Blades -
 Bi-Metal Heavy Duty & Demolition



p.68 Jig Saw Blades - Bi-Metal

p.69 Reciprocating Blades - Retail Packs



p.70 Hack-Saw Blades - Bi-Metal



p.70 Band-Saw Blades - Bi-Metal



p.71 Metal Racks



p.72 Multi Purpose Drills - Carbide



p.72 Glass Drills



p.72 Hard Steel Drills -
 Cast Iron / Safes

MAIN OFFICE
 INTERNATIONAL TOOL MANUFACTURING
 71-08 51ST. AVENUE, WOODSIDE, NY 11377
 (718) 446-0711 - (800) 247-5696 - FAX (718) 899-6553



INTERNATIONAL TOOL MANUFACTURING
 675-E-PROGRESS CENTER AVE., LAWRENCEVILLE, GA 30043
 (770) 962-5454 - (800) 229-1776 - FAX (770) 962-5869

V-Groove	p.73	
SDS+ Stop	p.73	
Masonry Drills - Zinc Plated - Fast Spiral / Slow Spiral	p.73	
Masonry Drills - Black Oxide - Slow Spiral	p.74	
Roto Percussion Masonry Drills	p.75	
Spline Hammer Drills	p.76	
SDS-Max Hammer Drills	p.79	
Core Cutters	p.80	
Ratio Drilling System	p.81	
Core Drills - Taper Shanks	p.82	
Core Drills - 1 Piece	p.83	
SDS-Plus Drills	p.84	
SDS 4X4 eVolution	p.86	
SDS REDLINE	p.87	
Extention Systems / Adapters	p.88	
Tap-Con Drills	p.89	
SDS-HEX Hammer Drills	p.89	
Chisels	p.90	
Rebar Cutters	p.92	

MAIN OFFICE
 INTERNATIONAL TOOL MANUFACTURING
 71-08 51ST. AVENUE, WOODSIDE, NY 11377
 (718) 446-0711 - (800) 247-5696 - FAX (718) 899-6553



INTERNATIONAL TOOL MANUFACTURING
 675-E-PROGRESS CENTER AVE., LAWRENCEVILLE, GA 30043
 (770) 962-5454 - (800) 229-1776 - FAX (770) 962-5869



p.93+ Diamond Blades



p.96+ Screw Driver Bits



p.102 Bit Holders



p.103 Nut Setters - Magnetic



p.105 Screw Drivers & Sets



p.107 Screw Driver - MEGAPRO



p.108 Sockets (Magnetic Impact) & Drivers



p.110 Cable Ties



p.111 Plastic Anchors

p.112 Plastic Anchor Kits



p.113 Metal Anchors



p.115 Accessories

p.116 Special Services

Terms Of Sale

Terms: 2% 10 Days, Net 30 Days. All credit cards welcome.

Credit: Open account privileges are extended to any firm that is satisfactorily rated. New accounts should submit at least 3 commercial references including all contact information. Outdated or erroneous information will delay establishment of account and it will be up to the respective firm to provide corrected information.

Quantities: Although there is no minimum purchase order, we reserve the right to adjust any order to the minimum packaged quantities indicated in catalog.

Freight: Prepaid for NET invoices equaling \$600 or more.

EFFECTIVE July 1, 2013.



expertise

because **drilling** solutions

Aqua, Chicago



Icon Brickell, Miami

can be out of the **ordinary**



HSS TOOL DATA

Suggested Drill Bits To Be used For Various Types Of Materials:

MATERIAL	DRILL STYLE	ANGLE POINT	PRESSURE TO APPLY	COOLANT OR LUBRICANT
CARBON STEEL DUCTILE STEEL BRASS BRONZE	GENERAL PURPOSE DRILLS	118° POINT	MEDIUM TO HEAVY	OIL or WATER SOLUTION
CARBON STEEL ALUMINUM AUSTENETIC STAINLESS STEEL	HEAVY DUTY AND TITANIUM	135° SPLIT POINT	MEDIUM TO HEAVY	OIL or ACTIVATED SOLUTION
STAINLESS STEEL SERIES C CAST IRON	COBALT DRILLS	135° SPLIT POINT	MEDIUM TO HEAVY	OIL or ACTIVATED SOLUTION
HARD STEEL HEAT TREATED ALLOYS	HARD BODY CARBIDE TIPPED AND COBALT	130° & 135° SPLIT POINT	HEAVY	OIL or ACTIVATED SOLUTION

Chemical Analysis Of The Two Primary High Speed Steels Used To Manufacture

ITM HSS Drill Bits:

TYPE	CHEMICAL COMPOSITION						ROCKWELL C HARDNESS	TERM
	CARBON	TUNGSTEN	MOLYBDENUM	CHROMIUM	VANADIUM	COBALT		
M2	0.85	6.00	5.00	4.00	1.90	-	63-65	HSS
M35	1.10	1.50	9.50	1.15	1.15	5.00	65-67	SUPER COBALT

M2 "HSS" is the standard material used for all ITM drill bits. M2 has good red-hardness and retains its cutting edge longer than other general purpose high speed steels because of its increased quantity of tungsten (dull red heat up to 1000° F without loss of hardness or rapid dulling of cutting edge).

M2 is generally favored for high production machine work.

M35 "Super Cobalt" is the standard cobalt material used for all ITM cobalt drill bits. M35 has excellent resistance to abrasion and very good red-hardness for working difficult materials.

COBALT DRILLS

Made of the finest Cobalt steel obtainable and furnished with a 135° split point, these drills are designed for use in machining hard, tough materials beyond the normal cutting capabilities of regular high speed steel tools. These include work-hardening grades of stainless steels, titanium, high temperature alloys, and many other heat treated materials. In addition, due to their resistant properties, they can also be used at higher speeds to drill abrasive plastics, cast iron, and other types of difficult to machine work materials.

THE TITANIUM ADVANTAGE

The Titanium Nitrate coating extends the life of the twist drill by up to 4 times. Titanium drills are mostly used in production because of their extended life. The Titanium Nitrate coating acts as a THERMAL BARRIER between the high speed drill and the material being drilled. This feature improves the speed and the drilling time by 40% to 50% over a standard HSS drill bit. Titanium drills are manufactured with a 135° split point for fast penetration and accurate starting without the use of a center punch. The precision ground point, flute, body clearances, and drill diameters are especially designed for ultimate accuracy and performance.



Always Use Safety Glasses When Drilling.

Always Use High RPM For Smaller Diameters and Lower RPM For Larger Diameters.

HSS TOOL DATA

Understanding High Speed Steel Drill Bits:

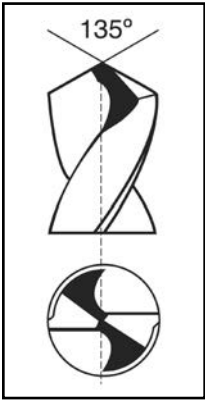
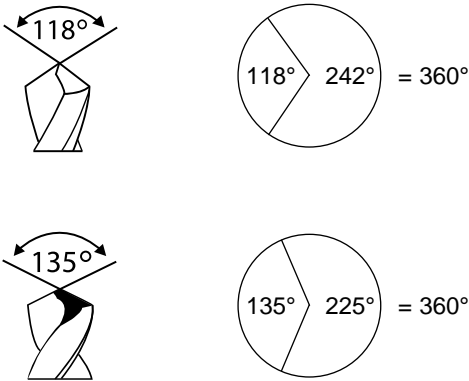

Split Point

An extra cutting angle on the 2 cutting edges of a drill bit.

Split Point is designated here in black.

Split Pointing is almost always reserved for 135° HSS drill bits.

118° drill bits have a sharp point and are common on standard / general purpose drill bits where light duty work is needed. Because of this sharp point, 118° drill bits will tend to “walk” or spin like a top on flat surfaces. This is why a centering drill or center punch is normally used to start off holes. If the operator has very steady hands, then the 118° drill bit can be used without center punching.

135° drill bits have a flatter point which gives the drill bit more cutting surface area. When more surface area cuts the steel, drilling is faster.

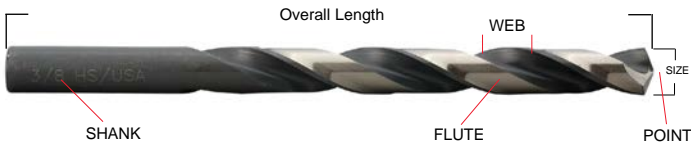

Understanding Nomenclature Vis-a-vis Size:

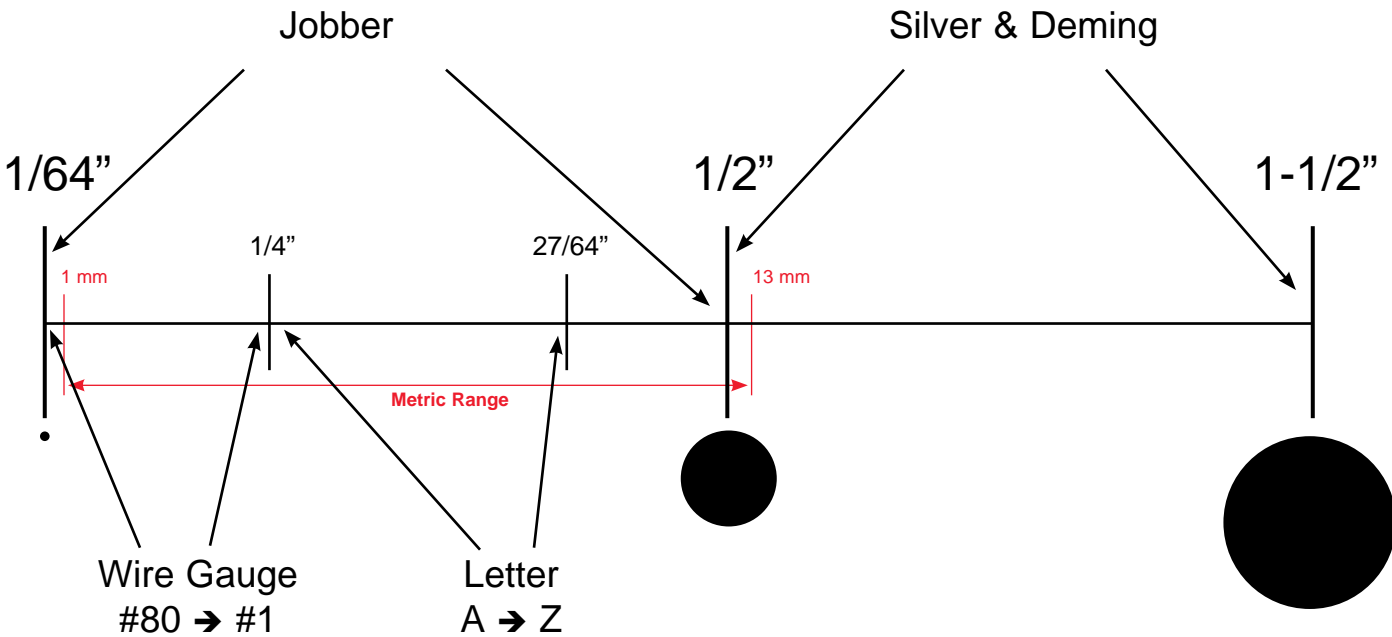

Chart Not To Scale.



Jobber Drills - General Purpose - TWO TONE FINISH M2 HSS

- ◆ Jobber Length
- ◆ 118° Point
- ◆ General Purpose
- ◆ Ground Flute
- ◆ Straight Shank
- ◆ Two Tone Finish
- ◆ M2 HSS
- Cast Iron
- Steel
- Steel Forging
- Light to Medium Materials

Part #	Size	Dec.	OAL	Flute	Qty.	List	Part #	Size	Dec.	OAL	Flute	Qty.	List
200HS0464	1/16"	.0625	1-7/8"	7/8"	12	\$0.90	200HS1964	19/64"	.2969	4-3/8"	3-1/16"	12	\$3.23
200HS0564	5/64"	.0781	2"	1"	12	\$0.90	200HS2064	5/16"	.3125	4-1/2"	3-3/16"	12	\$3.33
200HS0664	3/32"	.0938	2-1/4"	1-1/4"	12	\$0.90	200HS2164	21/64"	.3281	4-5/8"	3-5/16"	6	\$3.75
200HS0764	7/64"	.1094	2-5/8"	1-1/2"	12	\$0.90	200HS2264	11/32"	.3438	4-3/4"	3-7/16"	6	\$4.27
200HS0864	1/8"	.1250	2-3/4"	1-5/8"	12	\$0.90	200HS2364	23/64"	.3594	4-7/8"	3-1/2"	6	\$4.88
200HS0964	9/64"	.1406	2-7/8"	1-3/4"	12	\$1.00	200HS2464	3/8"	.3750	5"	3-5/8"	6	\$5.53
200HS1064	5/32"	.1562	3-1/8"	2"	12	\$1.04	200HS2564	25/64"	.3906	5-1/8"	3-3/4"	6	\$6.00
200HS1164	11/64"	.1719	3-1/4"	2-1/8"	12	\$1.14	200HS2664	13/32"	.4062	5-1/4"	3-1/8"	6	\$6.16
200HS1264	3/16"	.1875	3-1/2"	2-5/16"	12	\$1.26	200HS2764	27/64"	.4219	5-3/8"	3-15/16"	6	\$6.82
200HS1364	13/64"	.2031	3-5/8"	2-7/16"	12	\$1.46	200HS2864	7/16"	.4375	5-1/2"	4-1/16"	6	\$7.30
200HS1464	7/32"	.2188	3-3/4"	2-1/2"	12	\$1.63	200HS2964	29/64"	.4531	5-5/8"	4-3/16"	6	\$8.61
200HS1564	15/64"	.2344	3-7/8"	2-5/8"	12	\$1.87	200HS3064	15/32"	.4688	5-3/4"	4-5/16"	6	\$8.76
200HS1664	1/4"	.2500	4"	2-3/4"	12	\$2.11	200HS3164	31/64"	.4844	5-7/8"	4-3/8"	6	\$9.31
200HS1764	17/64"	.2656	4-1/8"	2-7/8"	12	\$2.63	200HS3264	1/2"	.5000	6"	4-1/2"	6	\$10.51
200HS1864	9/32"	.2812	4-1/4"	2-15/16"	12	\$3.00							



Jobber Drills - General Purpose 3/8" Shank - TWO TONE FINISH M2 HSS

- ◆ Same as above with 3/8" Shank.

Part #	Size	Dec.	OAL	Flute	Qty.	List	Part #	Size	Dec.	OAL	Flute	Qty.	List
200R82564	25/64"	.3906	5-1/8"	3-3/4"	6	\$6.89	200R82964	29/64"	.4531	5-5/8"	4-3/16"	6	\$9.90
200R82664	13/32"	.4062	5-1/4"	3-1/8"	6	\$7.08	200R83064	15/32"	.4688	5-3/4"	4-5/16"	6	\$10.07
200R82764	27/64"	.4219	5-3/8"	3-15/16"	6	\$7.84	200R83164	31/64"	.4844	5-7/8"	4-3/8"	6	\$10.70
200R82864	7/16"	.4375	5-1/2"	4-1/16"	6	\$8.40	200R83264	1/2"	.5000	6"	4-1/2"	6	\$12.08

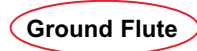

Jobber Drills - General Purpose - BRITE FINISH M2 HSS

- ◆ Jobber Length
- ◆ 118° Point
- ◆ General Purpose
- ◆ Ground Flute
- ◆ Straight Shank
- ◆ Brite Finish
- ◆ M2 HSS
- Cast Iron
- Steel
- Steel Forging
- Light to Medium Materials

Part #	Size	Dec.	OAL	Flute	Qty.	List	Part #	Size	Dec.	OAL	Flute	Qty.	List
250US0164	1/64"	.0156	3/4"	3/16"	12	\$1.39	250US1764	17/64"	.2656	4-1/8"	2-7/8"	12	\$3.67
250US0264	1/32"	.0312	1-3/8"	1/2"	12	\$1.39	250US1864	9/32"	.2812	4-1/4"	2-15/16"	12	\$3.94
250US0364	3/64"	.0469	1-3/4"	3/4"	12	\$1.39	250US1964	19/64"	.2969	4-3/8"	3-1/16"	12	\$4.45
250US0464	1/16"	.0625	1-7/8"	7/8"	12	\$0.90	250US2064	5/16"	.3125	4-1/2"	3-3/16"	12	\$5.45
250US0564	5/64"	.0781	2"	1"	12	\$0.90	250US2164	21/64"	.3281	4-5/8"	3-5/16"	6	\$5.73
250US0664	3/32"	.0938	2-1/4"	1-1/4"	12	\$0.90	250US2264	11/32"	.3438	4-3/4"	3-7/16"	6	\$6.23
250US0764	7/64"	.1094	2-5/8"	1-1/2"	12	\$0.90	250US2364	23/64"	.3594	4-7/8"	3-1/2"	6	\$7.15
250US0864	1/8"	.1250	2-3/4"	1-5/8"	12	\$0.96	250US2464	3/8"	.3750	5"	3-5/8"	6	\$7.65
250US0964	9/64"	.1406	2-7/8"	1-3/4"	12	\$1.10	250US2564	25/64"	.3906	5-1/8"	3-3/4"	6	\$9.44
250US1064	5/32"	.1562	3-1/8"	2"	12	\$1.33	250US2664	13/32"	.4062	5-1/4"	3-1/8"	6	\$10.08
250US1164	11/64"	.1719	3-1/4"	2-1/8"	12	\$1.60	250US2764	27/64"	.4219	5-3/8"	3-15/16"	6	\$10.73
250US1264	3/16"	.1875	3-1/2"	2-5/16"	12	\$1.83	250US2864	7/16"	.4375	5-1/2"	4-1/16"	6	\$11.14
250US1364	13/64"	.2031	3-5/8"	2-7/16"	12	\$2.06	250US2964	29/64"	.4531	5-5/8"	4-3/16"	6	\$11.84
250US1464	7/32"	.2188	3-3/4"	2-1/2"	12	\$2.25	250US3064	15/32"	.4688	5-3/4"	4-5/16"	6	\$13.81
250US1564	15/64"	.2344	3-7/8"	2-5/8"	12	\$2.70	250US3164	31/64"	.4844	5-7/8"	4-3/8"	6	\$14.25
250US1664	1/4"	.2500	4"	2-3/4"	12	\$3.12	250US3264	1/2"	.5000	6"	4-1/2"	6	\$15.58



Jobber Drills - General Purpose - BLACK FINISH M2 HSS

Part #	Size	Dec.	OAL	Flute	Qty.	List	Part #	Size	Dec.	OAL	Flute	Qty.	List
200BF0464	1/16"	.0625	1-7/8"	7/8"	12	\$0.64	200BF1964	19/64"	.2969	4-3/8"	3-1/16"	12	\$2.29
200BF0564	5/64"	.0781	2"	1"	12	\$0.64	200BF2064	5/16"	.3125	4-1/2"	3-3/16"	12	\$2.34
200BF0664	3/32"	.0938	2-1/4"	1-1/4"	12	\$0.64	200BF2164	21/64"	.3281	4-5/8"	3-5/16"	6	\$2.65
200BF0764	7/64"	.1094	2-5/8"	1-1/2"	12	\$0.64	200BF2264	11/32"	.3438	4-3/4"	3-7/16"	6	\$3.07
200BF0864	1/8"	.1250	2-3/4"	1-5/8"	12	\$0.64	200BF2364	23/64"	.3594	4-7/8"	3-1/2"	6	\$3.45
200BF0964	9/64"	.1406	2-7/8"	1-3/4"	12	\$0.70	200BF2464	3/8"	.3750	5"	3-5/8"	6	\$3.55
200BF1064	5/32"	.1562	3-1/8"	2"	12	\$0.72	200BF2564	25/64"	.3906	5-1/8"	3-3/4"	6	\$3.84
200BF1164	11/64"	.1719	3-1/4"	2-1/8"	12	\$0.81	200BF2664	13/32"	.4062	5-1/4"	3-7/8"	6	\$3.95
200BF1264	3/16"	.1875	3-1/2"	2-5/16"	12	\$0.89	200BF2764	27/64"	.4219	5-3/8"	3-15/16"	6	\$4.38
200BF1364	13/64"	.2031	3-5/8"	2-7/16"	12	\$1.03	200BF2864	7/16"	.4375	5-1/2"	4-1/16"	6	\$4.69
200BF1464	7/32"	.2188	3-3/4"	2-1/2"	12	\$1.13	200BF2964	29/64"	.4531	5-5/8"	4-3/16"	6	\$5.53
200BF1564	15/64"	.2344	3-7/8"	2-5/8"	12	\$1.32	200BF3064	15/32"	.4688	5-3/4"	4-5/16"	6	\$5.63
200BF1664	1/4"	.2500	4"	2-3/4"	12	\$1.48	200BF3164	31/64"	.4844	5-7/8"	4-3/8"	6	\$5.95
200BF1764	17/64"	.2656	4-1/8"	2-7/8"	12	\$1.86	200BF3264	1/2"	.5000	6"	4-1/2"	6	\$6.05
200BF1864	9/32"	.2812	4-1/4"	2-15/16"	12	\$2.12							

- ◆ Jobber Length
- ◆ 118° Point
- ◆ General Purpose
- ◆ Roll Forged
- ◆ Straight Shank
- ◆ Black Oxide Finish
- ◆ M2 HSS
- Cast Iron
- Steel
- Steel Forging
- Light to Medium Materials

Wire Gauge Drills - General Purpose - BLACK FINISH M2 HSS

Part #	Size	Dec.	OAL	Flute	Qty.	List	Part #	Size	Dec.	OAL	Flute	Qty.	List
203HS0001	1	.2280	3-7/8"	2-5/8"	12	\$1.59	203HS0031	31	.1200	2-3/4"	1-5/8"	12	\$0.91
203HS0002	2	.2210	3-7/8"	2-5/8"	12	\$1.59	203HS0032	32	.1160	2-3/4"	1-5/8"	12	\$0.91
203HS0003	3	.2130	3-3/4"	2-1/2"	12	\$1.72	203HS0033	33	.1130	2-5/8"	1-1/2"	12	\$0.91
203HS0004	4	.2090	3-3/4"	2-1/2"	12	\$1.72	203HS0034	34	.1110	2-5/8"	1-1/2"	12	\$0.91
203HS0005	5	.2055	3-3/4"	2-1/2"	12	\$1.72	203HS0035	35	.1100	2-5/8"	1-1/2"	12	\$0.91
203HS0006	6	.2040	3-3/4"	2-1/2"	12	\$1.72	203HS0036	36	.1065	2-1/2"	1-7/16"	12	\$0.91
203HS0007	7	.2010	3-5/8"	2-7/16"	12	\$1.72	203HS0037	37	.1040	2-1/2"	1-7/16"	12	\$0.91
203HS0008	8	.1990	3-5/8"	2-7/16"	12	\$1.72	203HS0038	38	.1015	2-1/2"	1-7/16"	12	\$0.91
203HS0009	9	.1960	3-5/8"	2-7/16"	12	\$1.72	203HS0039	39	.0995	2-3/8"	1-3/8"	12	\$0.91
203HS0010	10	.1935	3-5/8"	2-7/16"	12	\$1.72	203HS0040	40	.0980	2-3/8"	1-3/8"	12	\$0.91
203HS0011	11	.1910	3-1/2"	2-5/16"	12	\$1.63	203HS0041	41	.0960	2-3/8"	1-3/8"	12	\$0.91
203HS0012	12	.1890	3-1/2"	2-5/16"	12	\$1.63	203HS0042	42	.0935	2-1/4"	1-1/4"	12	\$0.91
203HS0013	13	.1850	3-1/2"	2-5/16"	12	\$1.63	203HS0043	43	.0890	2-1/4"	1-1/4"	12	\$0.91
203HS0014	14	.1820	3-3/8"	2-3/16"	12	\$1.63	203HS0044	44	.0860	2-1/8"	1-1/8"	12	\$0.91
203HS0015	15	.1800	3-3/8"	2-3/16"	12	\$1.63	203HS0045	45	.0820	2-1/8"	1-1/8"	12	\$0.91
203HS0016	16	.1770	3-3/8"	2-3/16"	12	\$1.63	203HS0046	46	.0810	2-1/8"	1-1/8"	12	\$0.91
203HS0017	17	.1730	3-3/8"	2-3/16"	12	\$1.63	203HS0047	47	.0785	2"	1"	12	\$0.91
203HS0018	18	.1695	3-1/4"	2-1/8"	12	\$1.63	203HS0048	48	.0760	2"	1"	12	\$0.91
203HS0019	19	.1660	3-1/4"	2-1/8"	12	\$1.63	203HS0049	49	.0730	2"	1"	12	\$0.91
203HS0020	20	.1610	3-1/4"	2-1/8"	12	\$1.46	203HS0050	50	.0700	2"	1"	12	\$0.91
203HS0021	21	.1590	3-1/4"	2-1/8"	12	\$1.46	203HS0051	51	.0670	2"	1"	12	\$0.91
203HS0022	22	.1570	3-1/8"	2"	12	\$1.53	203HS0052	52	.0635	1-7/8"	7/8"	12	\$0.91
203HS0023	23	.1540	3-1/8"	2"	12	\$1.53	203HS0053	53	.0595	1-7/8"	7/8"	12	\$0.91
203HS0024	24	.1520	3-1/8"	2"	12	\$1.09	203HS0054	54	.0550	1-7/8"	7/8"	12	\$0.91
203HS0025	25	.1495	3"	1-7/8"	12	\$1.09	203HS0055	55	.0520	1-7/8"	7/8"	12	\$0.91
203HS0026	26	.1470	3"	1-7/8"	12	\$1.09	203HS0056	56	.0465	1-3/4"	3/4"	12	\$0.91
203HS0027	27	.1440	3"	1-7/8"	12	\$1.09	203HS0057	57	.0430	1-3/4"	3/4"	12	\$0.91
203HS0028	28	.1405	2-7/8"	1-3/4"	12	\$1.09	203HS0058	58	.0420	1-5/8"	11/16"	12	\$0.91
203HS0029	29	.1360	2-7/8"	1-3/4"	12	\$0.91	203HS0059	59	.0410	1-5/8"	11/16"	12	\$0.91
203HS0030	30	.1285	2-3/4"	1-5/8"	12	\$0.91	203HS0060	60	.0400	1-5/8"	11/16"	12	\$0.91

- ◆ Wire Gauge
- ◆ 118° Point
- ◆ General Purpose
- ◆ Roll Forged
- ◆ Straight Shank
- ◆ Black Oxide Finish
- ◆ M2 HSS
- Cast Iron
- Steel
- Steel Forging
- Light to Medium Materials



AVAILABLE:
 SIZES 61 → 80
 List \$1.75



Jobber Drills - HEAVY DUTY - BLACK OXIDE FINISH M2 HSS

- ◆ Jobber Length
- ◆ 135° Split Point
- ◆ Ground Flute
- ◆ Straight Shank
- ◆ Heavy Duty Web
- ◆ Black Oxide Finish
- ◆ M2 HSS

- Cast Iron
- Steel
- Steel Forging
- Stainless

Part #	Size	Dec.	OAL	Flute	Qty.	List	Part #	Size	Dec.	OAL	Flute	Qty.	List
206SP0464	1/16"	.0625	1-7/8"	7/8"	12	\$1.06	206SP1964	19/64"	.2969	4-3/8"	3-1/16"	12	\$3.77
206SP0564	5/64"	.0781	2"	1"	12	\$1.06	206SP2064	5/16"	.3125	4-1/2"	3-3/16"	12	\$3.91
206SP0664	3/32"	.0938	2-1/4"	1-1/4"	12	\$1.06	206SP2164	21/64"	.3281	4-5/8"	3-5/16"	6	\$4.31
206SP0764	7/64"	.1094	2-5/8"	1-1/2"	12	\$1.06	206SP2264	11/32"	.3438	4-3/4"	3-7/16"	6	\$4.83
206SP0864	1/8"	.1250	2-3/4"	1-5/8"	12	\$1.18	206SP2364	23/64"	.3594	4-7/8"	3-1/2"	6	\$5.48
206SP0964	9/64"	.1406	2-7/8"	1-3/4"	12	\$1.26	206SP2464	3/8"	.3750	5"	3-5/8"	6	\$5.52
206SP1064	5/32"	.1562	3-1/8"	2"	12	\$1.32	206SP2564	25/64"	.3906	5-1/8"	3-3/4"	6	\$6.36
206SP1164	11/64"	.1719	3-1/4"	2-1/8"	12	\$1.49	206SP2664	13/32"	.4062	5-1/4"	3-7/8"	6	\$6.45
206SP1264	3/16"	.1875	3-1/2"	2-5/16"	12	\$1.61	206SP2764	27/64"	.4219	5-3/8"	3-15/16"	6	\$7.11
206SP1364	13/64"	.2031	3-5/8"	2-7/16"	12	\$1.92	206SP2864	7/16"	.4375	5-1/2"	4-1/16"	6	\$7.57
206SP1464	7/32"	.2188	3-3/4"	2-1/2"	12	\$1.95	206SP2964	29/64"	.4531	5-5/8"	4-3/16"	6	\$8.86
206SP1564	15/64"	.2344	3-7/8"	2-5/8"	12	\$2.24	206SP3064	15/32"	.4688	5-3/4"	4-5/16"	6	\$8.90
206SP1664	1/4"	.2500	4"	2-3/4"	12	\$2.55	206SP3164	31/64"	.4844	5-7/8"	4-3/8"	6	\$9.36
206SP1764	17/64"	.2656	4-1/8"	2-7/8"	12	\$2.82	206SP3264	1/2"	.5000	6"	4-1/2"	6	\$9.45
206SP1864	9/32"	.2812	4-1/4"	2-15/16"	12	\$3.49							



Wire Gauge Drills - HEAVY DUTY - BLACK OXIDE FINISH M2 HSS

- ◆ Wire Gauge
- ◆ 135° Split Point
- ◆ Ground Flute
- ◆ Straight Shank
- ◆ Heavy Duty Web
- ◆ Black Oxide Finish
- ◆ M2 HSS

- Cast Iron
- Steel
- Steel Forging
- Stainless

Part #	Size	Dec.	OAL	Flute	Qty.	List	Part #	Size	Dec.	OAL	Flute	Qty.	List
207SP0001	1	.2280	3-7/8"	2-5/8"	12	\$2.21	207SP0031	31	.1200	2-3/4"	1-5/8"	12	\$1.16
207SP0002	2	.2210	3-7/8"	2-5/8"	12	\$2.21	207SP0032	32	.1160	2-3/4"	1-5/8"	12	\$1.10
207SP0003	3	.2130	3-3/4"	2-1/2"	12	\$2.21	207SP0033	33	.1130	2-5/8"	1-1/2"	12	\$1.10
207SP0004	4	.2090	3-3/4"	2-1/2"	12	\$2.21	207SP0034	34	.1110	2-5/8"	1-1/2"	12	\$1.10
207SP0005	5	.2055	3-3/4"	2-1/2"	12	\$2.21	207SP0035	35	.1100	2-5/8"	1-1/2"	12	\$1.10
207SP0006	6	.2040	3-3/4"	2-1/2"	12	\$2.21	207SP0036	36	.1065	2-1/2"	1-7/16"	12	\$1.10
207SP0007	7	.2010	3-5/8"	2-7/16"	12	\$2.05	207SP0037	37	.1040	2-1/2"	1-7/16"	12	\$1.10
207SP0008	8	.1990	3-5/8"	2-7/16"	12	\$2.05	207SP0038	38	.1015	2-1/2"	1-7/16"	12	\$1.10
207SP0009	9	.1960	3-5/8"	2-7/16"	12	\$2.05	207SP0039	39	.0995	2-3/8"	1-3/8"	12	\$1.10
207SP0010	10	.1935	3-5/8"	2-7/16"	12	\$2.05	207SP0040	40	.0980	2-3/8"	1-3/8"	12	\$1.10
207SP0011	11	.1910	3-1/2"	2-5/16"	12	\$2.05	207SP0041	41	.0960	2-3/8"	1-3/8"	12	\$1.06
207SP0012	12	.1890	3-1/2"	2-5/16"	12	\$2.05	207SP0042	42	.0935	2-1/4"	1-1/4"	12	\$1.06
207SP0013	13	.1850	3-1/2"	2-5/16"	12	\$1.61	207SP0043	43	.0890	2-1/4"	1-1/4"	12	\$1.06
207SP0014	14	.1820	3-3/8"	2-3/16"	12	\$1.61	207SP0044	44	.0860	2-1/8"	1-1/8"	12	\$1.06
207SP0015	15	.1800	3-3/8"	2-3/16"	12	\$1.61	207SP0045	45	.0820	2-1/8"	1-1/8"	12	\$1.06
207SP0016	16	.1770	3-3/8"	2-3/16"	12	\$1.61	207SP0046	46	.0810	2-1/8"	1-1/8"	12	\$1.06
207SP0017	17	.1730	3-3/8"	2-3/16"	12	\$1.61	207SP0047	47	.0785	2"	1"	12	\$1.06
207SP0018	18	.1695	3-1/4"	2-1/8"	12	\$1.61	207SP0048	48	.0760	2"	1"	12	\$1.06
207SP0019	19	.1660	3-1/4"	2-1/8"	12	\$1.61	207SP0049	49	.0730	2"	1"	12	\$1.06
207SP0020	20	.1610	3-1/4"	2-1/8"	12	\$1.61	207SP0050	50	.0700	2"	1"	12	\$1.06
207SP0021	21	.1590	3-1/4"	2-1/8"	12	\$1.61	207SP0051	51	.0670	2"	1"	12	\$0.94
207SP0022	22	.1570	3-1/8"	2"	12	\$1.69	207SP0052	52	.0635	1-7/8"	7/8"	12	\$0.94
207SP0023	23	.1540	3-1/8"	2"	12	\$1.39	207SP0053	53	.0595	1-7/8"	7/8"	12	\$0.94
207SP0024	24	.1520	3-1/8"	2"	12	\$1.39	207SP0054	54	.0550	1-7/8"	7/8"	12	\$0.94
207SP0025	25	.1495	3"	1-7/8"	12	\$1.39	207SP0055	55	.0520	1-7/8"	7/8"	12	\$0.94
207SP0026	26	.1470	3"	1-7/8"	12	\$1.39	207SP0056	56	.0465	1-3/4"	3/4"	12	\$0.94
207SP0027	27	.1440	3"	1-7/8"	12	\$1.39	207SP0057	57	.0430	1-3/4"	3/4"	12	\$0.94
207SP0028	28	.1405	2-7/8"	1-3/4"	12	\$1.16	207SP0058	58	.0420	1-5/8"	11/16"	12	\$0.94
207SP0029	29	.1360	2-7/8"	1-3/4"	12	\$1.16	207SP0059	59	.0410	1-5/8"	11/16"	12	\$0.94
207SP0030	30	.1285	2-3/4"	1-5/8"	12	\$1.16	207SP0060	60	.0400	1-5/8"	11/16"	12	\$0.94



NOTE:
 SIZES 40 → 60
 HAVE NO
 SPLIT POINT.



Jobber Drills - HEAVY DUTY 3/8" Shank - BLACK OXIDE FINISH M2 HSS

Part #	Size	Dec.	OAL	Flute	Qty.	List	Part #	Size	Dec.	OAL	Flute	Qty.	List
206R82564	25/64"	.3906	5-1/8"	3-3/4"	6	\$10.08	206R82964	29/64"	.4531	5-5/8"	4-3/16"	6	\$13.22
206R82664	13/32"	.4062	5-1/4"	3-1/8"	6	\$10.16	206R83064	15/32"	.4688	5-3/4"	4-5/16"	6	\$13.61
206R82764	27/64"	.4219	5-3/8"	3-15/16"	6	\$11.50	206R83164	31/64"	.4844	5-7/8"	4-3/8"	6	\$14.51
206R82864	7/16"	.4375	5-1/2"	4-1/16"	6	\$11.67	206R83264	1/2"	.5000	6"	4-1/2"	6	\$14.42

◆ Same as 206SP with 3/8" Shank.



Letter Drills - HEAVY DUTY - BLACK OXIDE FINISH M2 HSS

Part #	Size	Dec.	OAL	Flute	Qty.	List	Part #	Size	Dec.	OAL	Flute	Qty.	List
208SP000A	A	.2340	3-7/8"	2-5/8"	12	\$2.97	208SP000N	N	.3020	4-3/8"	3-1/16"	6	\$5.11
208SP000B	B	.2380	4"	2-3/4"	12	\$3.11	208SP000O	O	.3160	4-1/2"	3-3/16"	6	\$5.24
208SP000C	C	.2420	4"	2-3/4"	12	\$3.11	208SP000P	P	.3230	4-5/8"	3-5/16"	6	\$5.66
208SP000D	D	.2460	4"	2-3/4"	12	\$3.11	208SP000Q	Q	.3320	4-3/4"	3-7/16"	6	\$5.75
208SP000E	E	.2500	4"	2-3/4"	12	\$3.11	208SP000R	R	.3390	4-3/4"	3-7/16"	6	\$5.75
208SP000F	F	.2570	4-1/8"	2-7/8"	12	\$3.82	208SP000S	S	.3480	4-7/8"	3-1/2"	6	\$7.04
208SP000G	G	.2610	4-1/8"	2-7/8"	12	\$3.82	208SP000T	T	.3580	4-7/8"	3-1/2"	6	\$7.04
208SP000H	H	.2660	4-1/8"	2-7/8"	12	\$3.89	208SP000U	U	.3680	5"	3-5/8"	6	\$7.23
208SP000I	I	.2720	4-1/8"	2-7/8"	12	\$3.89	208SP000V	V	.3770	5"	3-5/8"	6	\$7.23
208SP000J	J	.2770	4-1/8"	2-7/8"	12	\$4.34	208SP000W	W	.3860	5-1/8"	3-3/4"	6	\$8.20
208SP000K	K	.2810	4-1/4"	2-15/16"	12	\$4.34	208SP000X	X	.3970	5-1/8"	3-3/4"	6	\$9.37
208SP000L	L	.2900	4-1/4"	2-15/16"	6	\$4.99	208SP000Y	Y	.4040	5-1/4"	3-7/8"	6	\$9.67
208SP000M	M	.2950	4-3/8"	3-1/16"	6	\$5.11	208SP000Z	Z	.4130	5-1/4"	3-7/8"	6	\$10.87

- ◆ Jobber Length
- ◆ 135° Split Point
- ◆ Ground Flute
- ◆ Straight Shank
- ◆ Heavy Duty Web
- ◆ Black Oxide Finish
- ◆ M2 HSS

- Cast Iron
- Steel
- Steel Forging
- Stainless



Metric Drills - General Purpose - BLACK OXIDE FINISH M2 HSS

Part #	Size	Dec.	OAL	Flute	Qty.	List	Part #	Size	Dec.	OAL	Flute	Qty.	List
205HS0010	1	.0393	41	18	12	\$1.51	205HS0075	7.5	.2953	111	78	12	\$4.83
205HS0015	1.5	.0591	48	22	12	\$1.51	205HS0080	8	.3150	114	81	12	\$5.57
205HS0020	2	.0787	54	29	12	\$1.51	205HS0085	8.5	.3346	121	87	6	\$6.64
205HS0025	2.5	.0984	60	35	12	\$1.51	205HS0090	9	.3543	124	89	6	\$7.44
205HS0030	3	.1181	70	41	12	\$1.51	205HS0095	9.5	.3740	127	92	6	\$7.70
205HS0035	3.5	.1378	73	45	12	\$1.64	205HS0100	10	.3937	130	95	6	\$9.06
205HS0040	4	.1575	83	54	12	\$1.97	205HS0105	10.5	.4134	137	100	6	\$9.91
205HS0045	4.5	.1772	86	56	12	\$2.28	205HS0110	11	.4331	140	103	6	\$10.05
205HS0050	5	.1969	92	62	12	\$2.49	205HS0115	11.5	.4528	143	106	6	\$11.69
205HS0055	5.5	.2165	95	64	12	\$2.87	205HS0120	12	.4724	150	111	6	\$13.04
205HS0060	6	.2362	102	70	12	\$3.41	205HS0125	12.5	.4921	152	114	6	\$13.04
205HS0065	6.5	.2559	105	73	12	\$3.67	205HS0130	13	.5118	168	122	6	\$15.44
205HS0070	7	.2756	105	73	12	\$4.08							

- ◆ Metric Size
- ◆ 118° Point
- ◆ General Purpose
- ◆ Roll Forged
- ◆ Straight Shank
- ◆ Black Oxide Finish
- ◆ M2 HSS

- Cast Iron
- Steel
- Steel Forging
- Light to Medium Materials

MAIN OFFICE
 INTERNATIONAL TOOL MANUFACTURING
 71-08 51ST. AVENUE, WOODSIDE, NY 11377
 (718) 446-0711 - (800) 247-5696 - FAX (718) 899-6553



INTERNATIONAL TOOL MANUFACTURING
 675-E-PROGRESS CENTER AVE., LAWRENCEVILLE, GA 30043
 (770) 962-5454 - (800) 229-1776 - FAX (770) 962-5869



STUB Wire Gauge - HEAVY DUTY

- ◆ Stub Length → Cast Iron
- ◆ 135° Split Point → Steel
- ◆ Ground Flute → Steel Forging
- ◆ Straight Shank → Stainless
- ◆ Heavy Duty Web → Sheet Metal
- ◆ Black Oxide Finish → Automotive
- ◆ M2 HSS



STUB Fractional - HEAVY DUTY

Part #	Size	Dec.	OAL	Flute	Qty.	List
209SM0464	1/16"	.0625	1-5/8"	5/8"	12	\$1.10
209SM0564	5/64"	.0781	1-11/16"	11/16"	12	\$1.10
209SM0664	3/32"	.0938	1-3/4"	3/4"	12	\$1.10
209SM0764	7/64"	.1094	1-13/16"	13/16"	12	\$1.10
209SM0864	1/8"	.1250	1-7/8"	7/8"	12	\$1.10
209SM0964	9/64"	.1406	1-15/16"	15/16"	12	\$1.25
209SM1064	5/32"	.1562	2-1/16"	1"	12	\$1.25
209SM1164	11/64"	.1719	2-1/8"	1-1/16"	12	\$1.60
209SM1264	3/16"	.1875	2-3/16"	1-1/8"	12	\$1.44
209SM1364	13/64"	.2031	2-1/4"	1-3/16"	12	\$1.57
209SM1464	7/32"	.2188	2-3/8"	1-1/4"	12	\$1.81
209SM1564	15/64"	.2344	2-7/16"	1-5/16"	12	\$3.01
209SM1664	1/4"	.2500	2-1/2"	1-3/8"	12	\$2.37
209SM1764	17/64"	.2656	2-5/8"	1-7/16"	12	\$2.68
209SM1864	9/32"	.2812	2-11/16"	1-1/2"	12	\$3.22
209SM1964	19/64"	.2969	2-3/4"	1-9/16"	12	\$3.37
209SM2064	5/16"	.3125	2-13/16"	1-5/8"	12	\$3.51
209SM2164	21/64"	.3281	2-15/16"	1-11/16"	6	\$4.11
209SM2264	11/32"	.3438	3"	1-11/16"	6	\$4.35
209SM2364	23/64"	.3594	3-1/16"	1-3/4"	6	\$5.06
209SM2464	3/8"	.3750	3-1/8"	1-13/16"	6	\$5.82
209SM2564	25/64"	.3906	3-1/4"	1-7/8"	6	\$6.91
209SM2664	13/32"	.4062	3-5/16"	1-15/16"	6	\$7.01
209SM2764	27/64"	.4219	3-3/8"	2"	6	\$7.73
209SM2864	7/16"	.4375	3-7/16"	2-1/16"	6	\$7.83
209SM2964	29/64"	.4531	3-9/16"	2-1/8"	6	\$9.20
209SM3064	15/32"	.4688	3-5/8"	2-1/8"	6	\$9.34
209SM3164	31/64"	.4844	3-11/16"	2-3/16"	6	\$10.88
209SM3264	1/2"	.5000	3-3/4"	2-1/4"	6	\$10.88

Part #	Size	Dec.	OAL	Flute	Qty.	List
210SM0001	1	.2280	2-7/16"	1-15/16"	12	\$2.23
210SM0002	2	.2210	2-7/16"	1-15/16"	12	\$2.23
210SM0003	3	.2130	2-3/8"	1-1/4"	12	\$2.23
210SM0004	4	.2090	2-3/8"	1-1/4"	12	\$2.23
210SM0005	5	.2055	2-3/8"	1-1/4"	12	\$2.23
210SM0006	6	.2040	2-3/8"	1-1/4"	12	\$2.23
210SM0007	7	.2010	2-1/4"	1-3/16"	12	\$1.79
210SM0008	8	.1990	2-1/4"	1-3/16"	12	\$1.79
210SM0009	9	.1960	2-1/4"	1-3/16"	12	\$1.79
210SM0010	10	.1935	2-1/4"	1-3/16"	12	\$1.79
210SM0011	11	.1910	2-1/4"	1-3/16"	12	\$1.79
210SM0012	12	.1890	2-1/4"	1-3/16"	12	\$1.79
210SM0013	13	.1850	2-3/16"	1-1/8"	12	\$1.62
210SM0014	14	.1820	2-3/16"	1-1/8"	12	\$1.62
210SM0015	15	.1800	2-3/16"	1-1/8"	12	\$1.62
210SM0016	16	.1770	2-3/16"	1-1/8"	12	\$1.62
210SM0017	17	.1730	2-3/16"	1-1/8"	12	\$1.62
210SM0018	18	.1695	2-1/8"	1-1/16"	12	\$1.41
210SM0019	19	.1660	2-1/8"	1-1/16"	12	\$1.41
210SM0020	20	.1610	2-1/8"	1-1/16"	12	\$1.41
210SM0021	21	.1590	2-1/8"	1-1/16"	12	\$1.29
210SM0022	22	.1570	2-1/8"	1-1/16"	12	\$1.29
210SM0023	23	.1540	2-1/16"	1"	12	\$1.29
210SM0024	24	.1520	2-1/16"	1"	12	\$1.29
210SM0025	25	.1495	2-1/16"	1"	12	\$1.29
210SM0026	26	.1470	2-1/16"	1"	12	\$1.29
210SM0027	27	.1440	2-1/16"	1"	12	\$1.29
210SM0028	28	.1405	1-15/16"	15/16"	12	\$1.10
210SM0029	29	.1360	1-15/16"	15/16"	12	\$1.10
210SM0030	30	.1285	1-15/16"	15/16"	12	\$1.10
210SM0031	31	.1200	1-7/8"	7/8"	12	\$1.10
210SM0032	32	.1160	1-7/8"	7/8"	12	\$1.10
210SM0033	33	.1130	1-7/8"	7/8"	12	\$1.10
210SM0034	34	.1110	1-7/8"	7/8"	12	\$1.10
210SM0035	35	.1100	1-7/8"	7/8"	12	\$1.10
210SM0036	36	.1065	1-13/16"	13/16"	12	\$1.10
210SM0037	37	.1040	1-13/16"	13/16"	12	\$1.10
210SM0038	38	.1015	1-13/16"	13/16"	12	\$1.10
210SM0039	39	.0995	1-13/16"	13/16"	12	\$1.10
210SM0040	40	.0980	1-13/16"	13/16"	12	\$1.10



Silver & Deming - 1/2" Shank - M2 HSS

Part #	Size	Dec.	OAL	Flute	Qty.	List	Part #	Size	Dec.	OAL	Flute	Qty.	List
201SD3364	33/64"	.5156	6"	2-3/4"	1	\$13.88	201SD5364	53/64"	.8281	6"	2-3/4"	1	\$25.75
201SD3464	17/32"	.5312	6"	2-3/4"	1	\$14.11	201SD5464	27/32"	.8438	6"	2-3/4"	1	\$25.99
201SD3564	35/64"	.5469	6"	2-3/4"	1	\$14.32	201SD5564	55/64"	.8594	6"	2-3/4"	1	\$26.59
201SD3664	9/16"	.5625	6"	2-3/4"	1	\$14.32	201SD5664	7/8"	.8750	6"	2-3/4"	1	\$26.59
201SD3764	37/64"	.5781	6"	2-3/4"	1	\$16.03	201SD5764	57/64"	.8906	6"	2-3/4"	1	\$29.31
201SD3864	19/32"	.5938	6"	2-3/4"	1	\$16.03	201SD5864	29/32"	.9062	6"	2-3/4"	1	\$29.31
201SD3964	39/64"	.6094	6"	2-3/4"	1	\$16.25	201SD5964	59/64"	.9219	6"	2-3/4"	1	\$29.61
201SD4064	5/8"	.6250	6"	2-3/4"	1	\$16.25	201SD6064	15/16"	.9375	6"	2-3/4"	1	\$29.61
201SD4164	41/64"	.6406	6"	2-3/4"	1	\$17.36	201SD6164	61/64"	.9531	6"	2-3/4"	1	\$31.88
201SD4264	21/32"	.6562	6"	2-3/4"	1	\$17.36	201SD6264	31/32"	.9688	6"	2-3/4"	1	\$31.88
201SD4364	43/64"	.6719	6"	2-3/4"	1	\$18.12	201SD6364	63/64"	.9844	6"	2-3/4"	1	\$33.99
201SD4464	11/16"	.6875	6"	2-3/4"	1	\$20.84	201SD6464	1"	1.0000	6"	2-3/4"	1	\$37.39
201SD4564	45/64"	.7031	6"	2-3/4"	1	\$21.93	201SD6864	1-1/16"	1.0625	6"	2-3/4"	1	\$55.56
201SD4664	23/32"	.7188	6"	2-3/4"	1	\$21.93	201SD7264	1-1/8"	1.1250	6"	2-3/4"	1	\$58.27
201SD4764	47/64"	.7344	6"	2-3/4"	1	\$22.60	201SD7664	1-3/16"	1.1875	6"	2-3/4"	1	\$69.50
201SD4864	3/4"	.7500	6"	2-3/4"	1	\$22.60	201SD8064	1-1/4"	1.2500	6"	2-3/4"	1	\$80.48
201SD4964	49/64"	.7656	6"	2-3/4"	1	\$24.24	201SD8464	1-5/16"	1.3125	6"	2-3/4"	1	\$84.51
201SD5064	25/32"	.7812	6"	2-3/4"	1	\$24.24	201SD8864	1-3/8"	1.3750	6"	2-3/4"	1	\$91.83
201SD5164	51/64"	.7969	6"	2-3/4"	1	\$24.66	201SD9664	1-1/2"	1.5000	6"	2-3/4"	1	\$102.45
201SD5264	13/16"	.8125	6"	2-3/4"	1	\$24.66							

- ◆ 6" Length
 - ◆ 118° Point
 - ◆ Ground Flute
 - ◆ 1/2" Shank
 - ◆ Black Oxide Finish
 - ◆ M2 HSS
- Cast Iron
→ Steel
→ Steel Forging
→ Light to Medium Materials



BARCODED



Silver & Deming - 3/8" Shank - M2 HSS

Part #	Size	Dec.	OAL	Flute	Qty.	List	Part #	Size	Dec.	OAL	Flute	Qty.	List
201R83364	33/64"	.5156	6"	2-3/4"	1	\$13.27	201R84164	41/64"	.6406	6"	2-3/4"	1	\$22.89
201R83464	17/32"	.5312	6"	2-3/4"	1	\$14.57	201R84264	21/32"	.6562	6"	2-3/4"	1	\$22.89
201R83564	35/64"	.5469	6"	2-3/4"	1	\$19.07	201R84364	43/64"	.6719	6"	2-3/4"	1	\$22.89
201R83664	9/16"	.5625	6"	2-3/4"	1	\$19.07	201R84464	11/16"	.6875	6"	2-3/4"	1	\$22.89
201R83764	37/64"	.5781	6"	2-3/4"	1	\$21.03	201R84564	45/64"	.7031	6"	2-3/4"	1	\$23.78
201R83864	19/32"	.5938	6"	2-3/4"	1	\$21.03	201R84664	23/32"	.7188	6"	2-3/4"	1	\$23.78
201R83964	39/64"	.6094	6"	2-3/4"	1	\$21.03	201R84764	47/64"	.7344	6"	2-3/4"	1	\$24.97
201R84064	5/8"	.6250	6"	2-3/4"	1	\$21.03	201R84864	3/4"	.7500	6"	2-3/4"	1	\$24.97

- ◆ 6" Length
 - ◆ 118° Point
 - ◆ Ground Flute
 - ◆ 1/2" Shank
 - ◆ Black Oxide Finish
 - ◆ M2 HSS
- Cast Iron
→ Steel
→ Steel Forging
→ Light to Medium Materials



First Introduced in 1995...

Now the most recognizable
finish for High Speed Drill
Bits anywhere.

Black & Gold

MAIN OFFICE
 INTERNATIONAL TOOL MANUFACTURING
 71-08 51ST. AVENUE, WOODSIDE, NY 11377
 (718) 446-0711 - (800) 247-5696 - FAX (718) 899-6553



INTERNATIONAL TOOL MANUFACTURING
 675-E-PROGRESS CENTER AVE., LAWRENCEVILLE, GA 30043
 (770) 962-5454 - (800) 229-1776 - FAX (770) 962-5869



Black & Gold Jobber Drills - HEAVY DUTY - M2 HSS

Part #	Size	Dec.	OAL	Flute	Qty.	List	Part #	Size	Dec.	OAL	Flute	Qty.	List
206US0464	1/16"	.0625	1-7/8"	7/8"	12	\$1.39	206US1964	19/64"	.2969	4-3/8"	3-1/16"	12	\$4.96
206US0564	5/64"	.0781	2"	1"	12	\$1.39	206US2064	5/16"	.3125	4-1/2"	3-3/16"	12	\$5.14
206US0664	3/32"	.0938	2-1/4"	1-1/4"	12	\$1.39	206US2164	21/64"	.3281	4-5/8"	3-5/16"	6	\$5.67
206US0764	7/64"	.1094	2-5/8"	1-1/2"	12	\$1.39	206US2264	11/32"	.3438	4-3/4"	3-7/16"	6	\$6.35
206US0864	1/8"	.1250	2-3/4"	1-5/8"	12	\$1.55	206US2364	23/64"	.3594	4-7/8"	3-1/2"	6	\$7.22
206US0964	9/64"	.1406	2-7/8"	1-3/4"	12	\$1.66	206US2464	3/8"	.3750	5"	3-5/8"	6	\$7.26
206US1064	5/32"	.1562	3-1/8"	2"	12	\$1.74	206US2564	25/64"	.3906	5-1/8"	3-3/4"	6	\$8.37
206US1164	11/64"	.1719	3-1/4"	2-1/8"	12	\$1.97	206US2664	13/32"	.4062	5-1/4"	3-7/8"	6	\$8.49
206US1264	3/16"	.1875	3-1/2"	2-5/16"	12	\$2.14	206US2764	27/64"	.4219	5-3/8"	3-15/16"	6	\$9.35
206US1364	13/64"	.2031	3-5/8"	2-7/16"	12	\$2.53	206US2864	7/16"	.4375	5-1/2"	4-1/16"	6	\$9.95
206US1464	7/32"	.2188	3-3/4"	2-1/2"	12	\$2.58	206US2964	29/64"	.4531	5-5/8"	4-3/16"	6	\$11.66
206US1564	15/64"	.2344	3-7/8"	2-5/8"	12	\$2.94	206US3064	15/32"	.4688	5-3/4"	4-5/16"	6	\$11.72
206US1664	1/4"	.2500	4"	2-3/4"	12	\$3.37	206US3164	31/64"	.4844	5-7/8"	4-3/8"	6	\$12.32
206US1764	17/64"	.2656	4-1/8"	2-7/8"	12	\$3.71	206US3264	1/2"	.5000	6"	4-1/2"	6	\$12.41
206US1864	9/32"	.2812	4-1/4"	2-15/16"	12	\$4.59							

- ◆ Jobber Length
- ◆ 135° Split Point
- ◆ Ground Flute
- ◆ Straight Shank
- ◆ Heavy Duty Web
- ◆ Black & Gold Finish
- ◆ M2 HSS

- Cast Iron
- Steel
- Steel Forging
- Stainless Steel

Black & Gold Wire Gauge Drills - HEAVY DUTY - M2 HSS

Part #	Size	Dec.	OAL	Flute	Qty.	List	Part #	Size	Dec.	OAL	Flute	Qty.	List
207US-01	1	.2280	3-7/8"	2-5/8"	12	\$2.60	207US-31	31	.1200	2-3/4"	1-5/8"	12	\$1.45
207US-02	2	.2210	3-7/8"	2-5/8"	12	\$2.60	207US-32	32	.1160	2-3/4"	1-5/8"	12	\$1.17
207US-03	3	.2130	3-3/4"	2-1/2"	12	\$2.60	207US-33	33	.1130	2-5/8"	1-1/2"	12	\$1.17
207US-04	4	.2090	3-3/4"	2-1/2"	12	\$2.60	207US-34	34	.1110	2-5/8"	1-1/2"	12	\$1.17
207US-05	5	.2055	3-3/4"	2-1/2"	12	\$2.60	207US-35	35	.1100	2-5/8"	1-1/2"	12	\$1.17
207US-06	6	.2040	3-3/4"	2-1/2"	12	\$2.60	207US-36	36	.1065	2-1/2"	1-7/16"	12	\$1.17
207US-07	7	.2010	3-5/8"	2-7/16"	12	\$2.41	207US-37	37	.1040	2-1/2"	1-7/16"	12	\$1.17
207US-08	8	.1990	3-5/8"	2-7/16"	12	\$2.41	207US-38	38	.1015	2-1/2"	1-7/16"	12	\$1.17
207US-09	9	.1960	3-5/8"	2-7/16"	12	\$2.41	207US-39	39	.0995	2-3/8"	1-3/8"	12	\$1.17
207US-10	10	.1935	3-5/8"	2-7/16"	12	\$2.41	207US-40	40	.0980	2-3/8"	1-3/8"	12	\$1.17
207US-11	11	.1910	3-1/2"	2-5/16"	12	\$2.41	207US-41	41	.0960	2-3/8"	1-3/8"	12	\$1.00
207US-12	12	.1890	3-1/2"	2-5/16"	12	\$2.41	207US-42	42	.0935	2-1/4"	1-1/4"	12	\$1.00
207US-13	13	.1850	3-1/2"	2-5/16"	12	\$2.25	207US-43	43	.0890	2-1/4"	1-1/4"	12	\$1.00
207US-14	14	.1820	3-3/8"	2-3/16"	12	\$2.25	207US-44	44	.0860	2-1/8"	1-1/8"	12	\$1.00
207US-15	15	.1800	3-3/8"	2-3/16"	12	\$2.25	207US-45	45	.0820	2-1/8"	1-1/8"	12	\$1.00
207US-16	16	.1770	3-3/8"	2-3/16"	12	\$2.25	207US-46	46	.0810	2-1/8"	1-1/8"	12	\$1.00
207US-17	17	.1730	3-3/8"	2-3/16"	12	\$2.25	207US-47	47	.0785	2"	1"	12	\$1.00
207US-18	18	.1695	3-1/4"	2-1/8"	12	\$1.98	207US-48	48	.0760	2"	1"	12	\$1.00
207US-19	19	.1660	3-1/4"	2-1/8"	12	\$1.98	207US-49	49	.0730	2"	1"	12	\$1.00
207US-20	20	.1610	3-1/4"	2-1/8"	12	\$1.98	207US-50	50	.0700	2"	1"	12	\$1.00
207US-21	21	.1590	3-1/4"	2-1/8"	12	\$1.98	207US-51	51	.0670	2"	1"	12	\$1.00
207US-22	22	.1570	3-1/8"	2"	12	\$1.98	207US-52	52	.0635	1-7/8"	7/8"	12	\$1.00
207US-23	23	.1540	3-1/8"	2"	12	\$1.68	207US-53	53	.0595	1-7/8"	7/8"	12	\$1.00
207US-24	24	.1520	3-1/8"	2"	12	\$1.68	207US-54	54	.0550	1-7/8"	7/8"	12	\$1.00
207US-25	25	.1495	3"	1-7/8"	12	\$1.68	207US-55	55	.0520	1-7/8"	7/8"	12	\$1.00
207US-26	26	.1470	3"	1-7/8"	12	\$1.68	207US-56	56	.0465	1-3/4"	3/4"	12	\$1.00
207US-27	27	.1440	3"	1-7/8"	12	\$1.68	207US-57	57	.0430	1-3/4"	3/4"	12	\$1.00
207US-28	28	.1405	2-7/8"	1-3/4"	12	\$1.45	207US-58	58	.0420	1-5/8"	11/16"	12	\$1.00
207US-29	29	.1360	2-7/8"	1-3/4"	12	\$1.45	207US-59	59	.0410	1-5/8"	11/16"	12	\$1.00
207US-30	30	.1285	2-3/4"	1-5/8"	12	\$1.45	207US-60	60	.0400	1-5/8"	11/16"	12	\$1.00



BARCODED



NOTE:
 SIZES 40 → 60
 HAVE NO
 SPLIT POINT.



Black & Gold Jobber Drills - HEAVY DUTY 3/8" Shank - M2 HSS

◆ Same as 206US with 3/8" Shank.

Part #	Size	Dec.	OAL	Flute	Qty.	List	Part #	Size	Dec.	OAL	Flute	Qty.	List
206U82564	25/64"	.3906	5-1/8"	3-3/4"	6	\$10.82	206U82964	29/64"	.4531	5-5/8"	4-3/16"	6	\$13.96
206U82664	13/32"	.4062	5-1/4"	3-1/8"	6	\$11.16	206U83064	15/32"	.4688	5-3/4"	4-5/16"	6	\$14.32
206U82764	27/64"	.4219	5-3/8"	3-15/16"	6	\$11.72	206U83164	31/64"	.4844	5-7/8"	4-3/8"	6	\$14.36
206U82864	7/16"	.4375	5-1/2"	4-1/16"	6	\$12.58	206U83264	1/2"	.5000	6"	4-1/2"	6	\$15.44



Black & Gold Mechanics Length Drills - HEAVY DUTY - M2 HSS

- ◆ Mechanics Length
- ◆ 135° Split Point
- ◆ 3-Flat Shank (3/16" → 1/2")
- ◆ Gold & Black Oxide Finish
- ◆ Heavy Duty Web for Strength & Rigidity
- ◆ M2 HSS
- Cast Iron
- Steel
- Steel Forging
- Stainless Steel

Part #	Size	Dec.	OAL	Flute	Qty.	List	Part #	Size	Dec.	OAL	Flute	Qty.	List
208MC0464	1/16"	.0625	1 7/8"	7/8"	12	\$1.30	208MC1964	19/64"	.2969	3 7/8"	2-3/8"	12	\$4.93
208MC0564	5/64"	.0781	2"	1"	12	\$1.30	208MC2064	5/16"	.3125	4"	2-1/2"	12	\$5.01
208MC0664	3/32"	.0938	2 1/4"	1-1/4"	12	\$1.42	208MC2164	21/64"	.3281	4 1/16"	2-9/16"	6	\$5.64
208MC0764	7/64"	.1094	2 3/8"	1-5/16"	12	\$1.42	208MC2264	11/32"	.3438	4 1/8"	2-5/8"	6	\$6.15
208MC0864	1/8"	.1250	2 1/2"	1-7/16"	12	\$1.50	208MC2364	23/64"	.3594	4 3/16"	2-11/16"	6	\$6.51
208MC0964	9/64"	.1406	2 5/8"	1-9/16"	12	\$1.58	208MC2464	3/8"	.3750	4 1/4"	2-11/16"	6	\$6.75
208MC1064	5/32"	.1562	2 3/4"	1-11/16"	12	\$1.97	208MC2564	25/64"	.3906	4 5/16"	2-3/4"	6	\$7.61
208MC1164	11/64"	.1719	2 7/8"	1-13/16"	12	\$2.05	208MC2664	13/32"	.4062	4 3/8"	2-13/16"	6	\$7.89
208MC1264	3/16"	.1875	3"	1-7/8"	12	\$2.60	208MC2764	27/64"	.4219	4 7/16"	2-7/8"	6	\$8.40
208MC1364	13/64"	.2031	3 1/8"	1-15/16"	12	\$2.76	208MC2864	7/16"	.4375	4 1/2"	2-15/16"	6	\$9.15
208MC1464	7/32"	.2188	3 1/4"	2"	12	\$2.92	208MC2964	29/64"	.4531	4 5/8"	3"	6	\$10.45
208MC1564	15/64"	.2344	3 3/8"	2-1/16"	12	\$3.12	208MC3064	15/32"	.4688	4 3/4"	3-1/8"	6	\$11.04
208MC1664	1/4"	.2500	3 1/2"	2"	12	\$3.27	208MC3164	31/64"	.4844	4 7/8"	3-1/4"	6	\$11.08
208MC1764	17/64"	.2656	3 5/8"	2-1/8"	12	\$3.51	208MC3264	1/2"	.5000	5"	3-3/8"	6	\$11.83
208MC1864	9/32"	.2812	3 3/4"	2-1/4"	12	\$4.26							

MAIN OFFICE
 INTERNATIONAL TOOL MANUFACTURING
 71-08 51ST. AVENUE, WOODSIDE, NY 11377
 (718) 446-0711 - (800) 247-5696 - FAX (718) 899-6553



INTERNATIONAL TOOL MANUFACTURING
 675-E-PROGRESS CENTER AVE., LAWRENCEVILLE, GA 30043
 (770) 962-5454 - (800) 229-1776 - FAX (770) 962-5869



Black & Gold

Black & Gold Letter Drills - HEAVY DUTY - M2 HSS

Part #	Size	Dec.	OAL	Flute	Qty.	List	Part #	Size	Dec.	OAL	Flute	Qty.	List
208US-A	A	.234	3-7/8"	2-5/8"	12	\$4.25	208US-N	N	.302	4-3/8"	3-1/16"	6	\$5.57
208US-B	B	.238	4"	2-3/4"	12	\$4.25	208US-O	O	.316	4-1/2"	3-3/16"	6	\$6.02
208US-C	C	.242	4"	2-3/4"	12	\$4.25	208US-P	P	.323	4-5/8"	3-5/16"	6	\$6.58
208US-D	D	.246	4"	2-3/4"	12	\$4.25	208US-Q	Q	.332	4-3/4"	3-7/16"	6	\$6.87
208US-E	E	.250	4"	2-3/4"	12	\$4.25	208US-R	R	.339	4-3/4"	3-7/16"	6	\$6.87
208US-F	F	.257	4-1/8"	2-7/8"	12	\$4.45	208US-S	S	.348	4-7/8"	3-1/2"	6	\$7.53
208US-G	G	.261	4-1/8"	2-7/8"	12	\$4.45	208US-T	T	.358	4-7/8"	3-1/2"	6	\$8.21
208US-H	H	.266	4-1/8"	2-7/8"	12	\$4.45	208US-U	U	.368	5"	3-5/8"	6	\$8.88
208US-I	I	.272	4-1/8"	2-7/8"	12	\$4.86	208US-V	V	.377	5"	3-5/8"	6	\$8.88
208US-J	J	.277	4-1/8"	2-7/8"	12	\$4.86	208US-W	W	.386	5-1/8"	3-3/4"	6	\$8.88
208US-K	K	.281	4-1/4"	2-15/16"	12	\$4.86	208US-X	X	.397	5-1/8"	3-3/4"	6	\$10.64
208US-L	L	.290	4-1/4"	2-15/16"	6	\$5.43	208US-Y	Y	.404	5-1/4"	3-7/8"	6	\$10.86
208US-M	M	.295	4-3/8"	3-1/16"	6	\$5.57	208US-Z	Z	.413	5-1/4"	3-7/8"	6	\$11.71

- ◆ Jobber Length
- ◆ 135° Split Point
- ◆ Ground Flute
- ◆ Straight Shank
- ◆ Heavy Duty Web
- ◆ Black & Gold Finish
- ◆ M2 HSS

- Cast Iron
- Steel
- Steel Forging
- Stainless Steel



BARCODED



Black & Gold

Black & Gold Silver & Deming - 1/2" Shank - M2 HSS

Part #	Size	Dec.	OAL	Flute	Qty.	List	Part #	Size	Dec.	OAL	Flute	Qty.	List
201US3364	33/64"	.5156	6"	2-3/4"	1	\$17.24	201US5164	51/64"	.7969	6"	2-3/4"	1	\$32.04
201US3464	17/32"	.5312	6"	2-3/4"	1	\$17.24	201US5264	13/16"	.8125	6"	2-3/4"	1	\$32.04
201US3564	35/64"	.5469	6"	2-3/4"	1	\$17.92	201US5364	53/64"	.8281	6"	2-3/4"	1	\$33.04
201US3664	9/16"	.5625	6"	2-3/4"	1	\$17.92	201US5464	27/32"	.8438	6"	2-3/4"	1	\$33.04
201US3764	37/64"	.5781	6"	2-3/4"	1	\$18.44	201US5564	55/64"	.8594	6"	2-3/4"	1	\$35.40
201US3864	19/32"	.5938	6"	2-3/4"	1	\$18.44	201US5664	7/8"	.8750	6"	2-3/4"	1	\$35.40
201US3964	39/64"	.6094	6"	2-3/4"	1	\$18.72	201US5764	57/64"	.8906	6"	2-3/4"	1	\$35.90
201US4064	5/8"	.6250	6"	2-3/4"	1	\$18.72	201US5864	29/32"	.9062	6"	2-3/4"	1	\$35.90
201US4164	41/64"	.6406	6"	2-3/4"	1	\$19.64	201US5964	59/64"	.9219	6"	2-3/4"	1	\$37.60
201US4264	21/32"	.6562	6"	2-3/4"	1	\$19.64	201US6064	15/16"	.9375	6"	2-3/4"	1	\$37.60
201US4364	43/64"	.6719	6"	2-3/4"	1	\$20.32	201US6164	61/64"	.9531	6"	2-3/4"	1	\$39.88
201US4464	11/16"	.6875	6"	2-3/4"	1	\$20.32	201US6264	31/32"	.9688	6"	2-3/4"	1	\$39.88
201US4564	45/64"	.7031	6"	2-3/4"	1	\$21.36	201US6364	63/64"	.9844	6"	2-3/4"	1	\$42.04
201US4664	23/32"	.7188	6"	2-3/4"	1	\$21.36	201US6464	1"	1.0000	6"	2-3/4"	1	\$42.04
201US4764	47/64"	.7344	6"	2-3/4"	1	\$30.36	201US6864	1-1/16"	1.0625	6	2-3/4"	1	\$45.17
201US4864	3/4"	.7500	6"	2-3/4"	1	\$30.36	201US7264	1-1/8"	1.1250	6	2-3/4"	1	\$47.79
201US4964	49/64"	.7656	6"	2-3/4"	1	\$31.32	201US7664	1-3/16"	1.1875	6	2-3/4"	1	\$53.04
201US5064	25/32"	.7812	6"	2-3/4"	1	\$31.32	201US8064	1-1/4"	1.2500	6	2-3/4"	1	\$59.00

- ◆ 6" Length
- ◆ 118° Split Point
- ◆ Ground Flute
- ◆ 3-Flat Round 1/2" Shank
- ◆ Heavy Duty Web
- ◆ Black & Gold Finish
- ◆ M2 HSS

- Cast Iron
- Steel
- Steel Forging
- Stainless Steel



Cobalt Jobber Drills - SUPER HEAVY DUTY - M35 SUPER COBALT

- ◆ Jobber Length
- ◆ 135° Split Point
- ◆ Ground Flute
- ◆ Straight Shank
- ◆ Heavy Duty Web
- ◆ Gold Finish
- ◆ M35 Super Cobalt

- Hardened Steel
- Stainless Steel
- High Temp Alloys
- Heat Treated Materials
- Abrasive Plastics

Part #	Size	Dec.	OAL	Flute	Qty.	List	Part #	Size	Dec.	OAL	Flute	Qty.	List
219CO0464	1/16"	.0625	1-7/8"	7/8"	12	\$1.67	219CO1964	19/64"	.2969	4-3/8"	3-1/16"	12	\$7.63
219CO0564	5/64"	.0781	2"	1"	12	\$1.85	219CO2064	5/16"	.3125	4-1/2"	3-3/16"	12	\$8.18
219CO0664	3/32"	.0938	2-1/4"	1-1/4"	12	\$2.01	219CO2164	21/64"	.3281	4-5/8"	3-5/16"	6	\$8.98
219CO0764	7/64"	.1094	2-5/8"	1-1/2"	12	\$2.13	219CO2264	11/32"	.3438	4-3/4"	3-7/16"	6	\$10.39
219CO0864	1/8"	.1250	2-3/4"	1-5/8"	12	\$2.42	219CO2364	23/64"	.3594	4-7/8"	3-1/2"	6	\$11.81
219CO0964	9/64"	.1406	2-7/8"	1-3/4"	12	\$2.59	219CO2464	3/8"	.3750	5"	3-5/8"	6	\$12.39
219CO1064	5/32"	.1562	3-1/8"	2"	12	\$2.86	219CO2564	25/64"	.3906	5-1/8"	3-3/4"	6	\$13.06
219CO1164	11/64"	.1719	3-1/4"	2-1/8"	12	\$3.03	219CO2664	13/32"	.4062	5-1/4"	3-7/8"	6	\$13.95
219CO1264	3/16"	.1875	3-1/2"	2-5/16"	12	\$3.32	219CO2764	27/64"	.4219	5-3/8"	3-15/16"	6	\$14.75
219CO1364	13/64"	.2031	3-5/8"	2-7/16"	12	\$4.39	219CO2864	7/16"	.4375	5-1/2"	4-1/16"	6	\$15.34
219CO1464	7/32"	.2188	3-3/4"	2-1/2"	12	\$4.69	219CO2964	29/64"	.4531	5-5/8"	4-3/16"	6	\$18.38
219CO1564	15/64"	.2344	3-7/8"	2-5/8"	12	\$5.16	219CO3064	15/32"	.4688	5-3/4"	4-5/16"	6	\$18.73
219CO1664	1/4"	.2500	4"	2-3/4"	12	\$5.62	219CO3164	31/64"	.4844	5-7/8"	4-3/8"	6	\$19.17
219CO1764	17/64"	.2656	4-1/8"	2-7/8"	12	\$6.05	219CO3264	1/2"	.5000	6"	4-1/2"	6	\$19.75
219CO1864	9/32"	.2812	4-1/4"	2-15/16"	12	\$6.62							

Cobalt Wire Gauge Drills - SUPER HEAVY DUTY - M35 SUPER COBALT



BARCODED



NOTE:
 SIZES 40 → 60
 HAVE NO
 SPLIT POINT.

Part #	Size	Dec.	OAL	Flute	Qty.	List	Part #	Size	Dec.	OAL	Flute	Qty.	List
220CO0001	1	.2280	3-7/8"	2-5/8"	12	\$5.06	220CO0031	31	.1200	2-3/4"	1-5/8"	12	\$2.44
220CO0002	2	.2210	3-7/8"	2-5/8"	12	\$5.06	220CO0032	32	.1160	2-3/4"	1-5/8"	12	\$2.44
220CO0003	3	.2130	3-3/4"	2-1/2"	12	\$5.06	220CO0033	33	.1130	2-5/8"	1-1/2"	12	\$2.44
220CO0004	4	.2090	3-3/4"	2-1/2"	12	\$5.06	220CO0034	34	.1110	2-5/8"	1-1/2"	12	\$2.44
220CO0005	5	.2055	3-3/4"	2-1/2"	12	\$5.06	220CO0035	35	.1100	2-5/8"	1-1/2"	12	\$2.44
220CO0006	6	.2040	3-3/4"	2-1/2"	12	\$5.06	220CO0036	36	.1065	2-1/2"	1-7/16"	12	\$2.44
220CO0007	7	.2010	3-5/8"	2-7/16"	12	\$3.84	220CO0037	37	.1040	2-1/2"	1-7/16"	12	\$2.44
220CO0008	8	.1990	3-5/8"	2-7/16"	12	\$3.84	220CO0038	38	.1015	2-1/2"	1-7/16"	12	\$2.44
220CO0009	9	.1960	3-5/8"	2-7/16"	12	\$3.84	220CO0039	39	.0995	2-3/8"	1-3/8"	12	\$2.44
220CO0010	10	.1935	3-5/8"	2-7/16"	12	\$3.84	220CO0040	40	.0980	2-3/8"	1-3/8"	12	\$2.44
220CO0011	11	.1910	3-1/2"	2-5/16"	12	\$3.84	220CO0041	41	.0960	2-3/8"	1-3/8"	12	\$2.44
220CO0012	12	.1890	3-1/2"	2-5/16"	12	\$3.84	220CO0042	42	.0935	2-1/4"	1-1/4"	12	\$2.44
220CO0013	13	.1850	3-1/2"	2-5/16"	12	\$3.84	220CO0043	43	.0890	2-1/4"	1-1/4"	12	\$2.44
220CO0014	14	.1820	3-3/8"	2-3/16"	12	\$3.84	220CO0044	44	.0860	2-1/8"	1-1/8"	12	\$2.44
220CO0015	15	.1800	3-3/8"	2-3/16"	12	\$3.84	220CO0045	45	.0820	2-1/8"	1-1/8"	12	\$2.44
220CO0016	16	.1770	3-3/8"	2-3/16"	12	\$3.84	220CO0046	46	.0810	2-1/8"	1-1/8"	12	\$2.44
220CO0017	17	.1730	3-3/8"	2-3/16"	12	\$3.84	220CO0047	47	.0785	2"	1"	12	\$2.44
220CO0018	18	.1695	3-1/4"	2-1/8"	12	\$3.84	220CO0048	48	.0760	2"	1"	12	\$2.44
220CO0019	19	.1660	3-1/4"	2-1/8"	12	\$2.85	220CO0049	49	.0730	2"	1"	12	\$2.44
220CO0020	20	.1610	3-1/4"	2-1/8"	12	\$2.85	220CO0050	50	.0700	2"	1"	12	\$2.44
220CO0021	21	.1590	3-1/4"	2-1/8"	12	\$2.85	220CO0051	51	.0670	2"	1"	12	\$2.44
220CO0022	22	.1570	3-1/8"	2"	12	\$2.85	220CO0052	52	.0635	1-7/8"	7/8"	12	\$2.44
220CO0023	23	.1540	3-1/8"	2"	12	\$2.85	220CO0053	53	.0595	1-7/8"	7/8"	12	\$2.44
220CO0024	24	.1520	3-1/8"	2"	12	\$2.85	220CO0054	54	.0550	1-7/8"	7/8"	12	\$2.44
220CO0025	25	.1495	3"	1-7/8"	12	\$2.85	220CO0055	55	.0520	1-7/8"	7/8"	12	\$2.44
220CO0026	26	.1470	3"	1-7/8"	12	\$2.85	220CO0056	56	.0465	1-3/4"	3/4"	12	\$2.44
220CO0027	27	.1440	3"	1-7/8"	12	\$2.85	220CO0057	57	.0430	1-3/4"	3/4"	12	\$2.44
220CO0028	28	.1405	2-7/8"	1-3/4"	12	\$2.85	220CO0058	58	.0420	1-5/8"	11/16"	12	\$2.44
220CO0029	29	.1360	2-7/8"	1-3/4"	12	\$2.85	220CO0059	59	.0410	1-5/8"	11/16"	12	\$2.44
220CO0030	30	.1285	2-3/4"	1-5/8"	12	\$2.44	220CO0060	60	.0400	1-5/8"	11/16"	12	\$2.44



Cobalt Jobber Drills - 3/8" Shank - M35 SUPER COBALT

Part #	Size	Dec.	OAL	Flute	Qty.	List	Part #	Size	Dec.	OAL	Flute	Qty.	List
219R82564	25/64"	.3906	5-1/8"	3-3/4"	6	\$14.81	219R82964	29/64"	.4531	5-5/8"	4-3/16"	6	\$19.62
219R82664	13/32"	.4062	5-1/4"	3-1/8"	6	\$16.02	219R83064	15/32"	.4688	5-3/4"	4-5/16"	6	\$21.02
219R82764	27/64"	.4219	5-3/8"	3-15/16"	6	\$17.10	219R83164	31/64"	.4844	5-7/8"	4-3/8"	6	\$22.33
219R82864	7/16"	.4375	5-1/2"	4-1/16"	6	\$18.44	219R83264	1/2"	.5000	6"	4-1/2"	6	\$23.54

◆ Same as 219CO with 3/8" Shank.



BARCODED



Cobalt Stub Fractional - M35 SUPER COBALT

Part #	Size	Dec.	OAL	Flute	Qty.	List	Part #	Size	Dec.	OAL	Flute	Qty.	List
CTS-0464	1/16"	.0625	1-5/8"	5/8"	12	\$1.25	CTS-1964	19/64"	.2969	2-3/4"	1-9/16"	12	\$6.94
CTS-0564	5/64"	.0781	1-11/16"	11/16"	12	\$1.25	CTS-2064	5/16"	.3125	2-13/16"	1-5/8"	12	\$8.33
CTS-0664	3/32"	.0938	1-3/4"	3/4"	12	\$1.33	CTS-2164	21/64"	.3281	2-15/16"	1-11/16"	6	\$8.96
CTS-0764	7/64"	.1094	1-13/16"	13/16"	12	\$1.50	CTS-2264	11/32"	.3438	3"	1-11/16"	6	\$9.58
CTS-0864	1/8"	.1250	1-7/8"	7/8"	12	\$1.75	CTS-2364	23/64"	.3594	3-1/16"	1-3/4"	6	\$11.18
CTS-0964	9/64"	.1406	1-15/16"	15/16"	12	\$2.00	CTS-2464	3/8"	.3750	3-1/8"	1-13/16"	6	\$10.76
CTS-1064	5/32"	.1562	2-1/16"	1"	12	\$1.94	CTS-2564	25/64"	.3906	3-1/4"	1-7/8"	6	\$12.71
CTS-1164	11/64"	.1719	2-1/8"	1-1/16"	12	\$2.22	CTS-2664	13/32"	.4062	3-5/16"	1-15/16"	6	\$13.99
CTS-1264	3/16"	.1875	2-3/16"	1-1/8"	12	\$2.50	CTS-2764	27/64"	.4219	3-3/8"	2"	6	\$14.67
CTS-1364	13/64"	.2031	2-1/4"	1-3/16"	12	\$2.92	CTS-2864	7/16"	.4375	3-7/16"	2-1/16"	6	\$15.89
CTS-1464	7/32"	.2188	2-3/8"	1-1/4"	12	\$3.40	CTS-2964	29/64"	.4531	3-9/16"	2-1/8"	6	\$15.72
CTS-1564	15/64"	.2344	2-7/16"	1-5/16"	12	\$3.96	CTS-3064	15/32"	.4688	3-5/8"	2-1/8"	6	\$17.28
CTS-1664	1/4"	.2500	2-1/2"	1-3/8"	12	\$4.86	CTS-3164	31/64"	.4844	3-11/16"	2-3/16"	6	\$18.02
CTS-1764	17/64"	.2656	2-5/8"	1-7/16"	12	\$5.21	CTS-3264	1/2"	.5000	3-3/4"	2-1/4"	6	\$18.05
CTS-1864	9/32"	.2812	2-11/16"	1-1/2"	12	\$5.76							

- ◆ Stub Length
- ◆ 135° Split Point
- ◆ Ground Flute
- ◆ Straight Shank
- ◆ Heavy Duty Web
- ◆ Gold Finish
- ◆ M35 Super Cobalt

- Cast Iron
- Hardened Steel
- Stainless Steel
- Sheet Metal
- High Temp Alloys
- Heat Treated Materials
- Automotive



Cobalt Silver & Deming - 1/2" Shank - M35 SUPER COBALT

Part #	Size	Dec.	OAL	Flute	Qty.	List	Part #	Size	Dec.	OAL	Flute	Qty.	List
201CO3464	17/32"	.5312	6	2-3/4"	1	\$36.19	201CO5864	29/32"	.9062	6	2-3/4"	1	\$72.38
201CO3664	9/16"	.5625	6	2-3/4"	1	\$41.71	201CO6064	15/16"	.9375	6	2-3/4"	1	\$77.28
201CO3864	19/32"	.5938	6	2-3/4"	1	\$44.16	201CO6264	31/32"	.9688	6	2-3/4"	1	\$87.98
201CO4064	5/8"	.6250	6	2-3/4"	1	\$46.62	201CO6464	1"	1.0000	6	2-3/4"	1	\$90.78
201CO4264	21/32"	.6562	6	2-3/4"	1	\$49.69	201CO6864	1-1/16"	1.0625	6	2-3/4"	1	\$106.72
201CO4464	11/16"	.6875	6	2-3/4"	1	\$52.13	201CO7265	1-1/8"	1.1250	6	2-3/4"	1	\$121.45
201CO4664	23/32"	.7188	6	2-3/4"	1	\$54.59	201CO7664	1-3/16"	1.1875	6	2-3/4"	1	\$134.95
201CO4864	3/4"	.7500	6	2-3/4"	1	\$57.05	201CO8064	1-1/4"	1.2500	6	2-3/4"	1	\$145.98
201CO5064	25/32"	.7812	6	2-3/4"	1	\$59.49	201CO8464	1-5/16"	1.3125	6	2-3/4"	1	\$158.25
201CO5264	13/16"	.8125	6	2-3/4"	1	\$63.79	201CO8864	1-3/8"	1.3750	6	2-3/4"	1	\$169.29
201CO5464	27/32"	.8438	6	2-3/4"	1	\$66.24	201CO9664	1-1/2"	1.5000	6	2-3/4"	1	\$182.79
201CO5664	7/8"	.8750	6	2-3/4"	1	\$68.70							

- ◆ 6" Length
- ◆ 118° Split Point
- ◆ Ground Flute
- ◆ 3-Flat Round 1/2" Shank
- ◆ Gold Finish
- ◆ M35 Cobalt

- Cast Iron
- Steel
- Steel Forging
- Stainless Steel



Titanium Jobber Drills - (TiN) Titanium Nitride Coating

- ◆ Jobber Length
- ◆ 135° Split Point
- ◆ Ground Flute
- ◆ Straight Shank
- ◆ Heavy Duty Web
- ◆ TiN Coating

- Cast Iron
- Steel
- Tool Steel
- Alloys



Part #	Size	Dec.	OAL	Flute	Qty.	List	Part #	Size	Dec.	OAL	Flute	Qty.	List
255SP0464	1/16"	.0625	1-7/8"	7/8"	12	\$2.47	255SP1964	19/64"	.2969	4-3/8"	3-1/16"	12	\$8.47
255SP0564	5/64"	.0781	2"	1"	12	\$2.47	255SP2064	5/16"	.3125	4-1/2"	3-3/16"	12	\$8.63
255SP0664	3/32"	.0938	2-1/4"	1-1/4"	12	\$2.47	255SP2164	21/64"	.3281	4-5/8"	3-5/16"	6	\$8.98
255SP0764	7/64"	.1094	2-5/8"	1-1/2"	12	\$2.47	255SP2264	11/32"	.3438	4-3/4"	3-7/16"	6	\$9.28
255SP0864	1/8"	.1250	2-3/4"	1-5/8"	12	\$2.47	255SP2364	23/64"	.3594	4-7/8"	3-1/2"	6	\$12.65
255SP0964	9/64"	.1406	2-7/8"	1-3/4"	12	\$2.51	255SP2464	3/8"	.3750	5"	3-5/8"	6	\$13.14
255SP1064	5/32"	.1562	3-1/8"	2"	12	\$2.51	255SP2564	25/64"	.3906	5-1/8"	3-3/4"	6	\$15.37
255SP1164	11/64"	.1719	3-1/4"	2-1/8"	12	\$2.70	255SP2664	13/32"	.4062	5-1/4"	3-7/8"	6	\$15.61
255SP1264	3/16"	.1875	3-1/2"	2-5/16"	12	\$2.76	255SP2764	27/64"	.4219	5-3/8"	3-15/16"	6	\$16.20
255SP1364	13/64"	.2031	3-5/8"	2-7/16"	12	\$4.94	255SP2864	7/16"	.4375	5-1/2"	4-1/16"	6	\$16.83
255SP1464	7/32"	.2188	3-3/4"	2-1/2"	12	\$5.17	255SP2964	29/64"	.4531	5-5/8"	4-3/16"	6	\$17.41
255SP1564	15/64"	.2344	3-7/8"	2-5/8"	12	\$5.23	255SP3064	15/32"	.4688	5-3/4"	4-5/16"	6	\$17.90
255SP1664	1/4"	.2500	4"	2-3/4"	12	\$5.26	255SP3164	31/64"	.4844	5-7/8"	4-3/8"	6	\$18.33
255SP1764	17/64"	.2656	4-1/8"	2-7/8"	12	\$7.88	255SP3264	1/2"	.5000	6"	4-1/2"	6	\$18.54
255SP1864	9/32"	.2812	4-1/4"	2-15/16"	12	\$8.00							



Spotweld - Double End - M42 Cobalt

- ◆ Heavy Duty Spur
- ◆ M42 Super Cobalt
- ◆ High Red Hot Hardness
- ◆ Double End
- ◆ Gold Finish

Part #	Size	Frac.	OAL	Qty.	List
219DE0065	6.5 mm	1/4"	3-5/8"	5	\$19.99
219DE0080	8.0 mm	5/16"	3-5/8"	5	\$26.04
219DE0100	10.0 mm	3/8"	3-5/8"	5	\$38.94



Double End - M2 SUPER HSS

Double End - M2 HSS BLACK

- ◆ Heavy Duty
- ◆ 135° Split Point
- ◆ M2 HSS
- ◆ Bright Finish

Part #	Size	Dec.	OAL	Flute	Qty.	List
211DE0764	7/64"	.1094	1-7/8"	1/2"	12	\$1.06
211DE0864	1/8"	.1250	2"	1/2"	12	\$1.14
211DE0964	9/64"	.1406	2"	1/2"	12	\$1.24
211DE1064	5/32"	.1562	2-1/16"	1/2"	12	\$1.38
211DE1264	3/16"	.1875	2-3/16"	1/2"	12	\$1.89
211DE1664	1/4"	.2500	2-1/2"	1/2"	12	\$2.98
211DE0030	#30	.1285	2"	1/2"	12	\$1.20

Part #	Size	Dec.	OAL	Flute	Qty.	List
211DE0864-B	1/8"	.1250	2"	1/2"	12	\$1.14
211DE0030-B	#30	.1285	2"	1/2"	12	\$1.20

- Black Oxide Finish



6" Cobalt Aircraft - M35 SUPER CO.

Part #	Size	Dec.	OAL	Flute	Qty.	List
212CO0464	1/16"	.0625	6"	7/8"	6	\$6.18
212CO0864	1/8"	.1250	6"	1-5/8"	6	\$6.11
212CO1064	5/32"	.1562	6"	2"	6	\$6.18
212CO1164	11/64"	.1719	6"	2-1/8"	6	\$7.43
212CO1264	3/16"	.1875	6"	2-5/16"	6	\$7.43
212CO1464	7/32"	.2188	6"	2-1/2"	6	\$9.24
212CO1664	1/4"	.2500	6"	2-3/4"	6	\$11.46
212CO2064	5/16"	.3125	6"	3-3/16"	1	\$22.30
212CO2464	3/8"	.3750	6"	3-5/8"	1	\$28.17

- ◆ Straight Shank
- ◆ 135° Split Point
- ◆ Ground Flute
- ◆ Extra Flexibility
- ◆ Heavy Duty Web
- ◆ Gold Finish
- ◆ M35 Super Cobalt

- Stainless Steel
- Heat Treated Materials



135° SPLIT POINT



6" Aircraft - M2 HSS

Part #	Size	Dec.	OAL	Flute	Qty.	List
212SP0464	1/16"	.0625	6"	7/8"	6	\$4.28
212SP0864	1/8"	.1250	6"	1-5/8"	6	\$4.28
212SP0964	9/64"	.1406	6"	1-3/4"	6	\$4.28
212SP1064	5/32"	.1562	6"	2"	6	\$4.28
212SP1164	11/64"	.1719	6"	2-1/8"	6	\$4.56
212SP1264	3/16"	.1875	6"	2-5/16"	6	\$4.89
212SP1364	13/64"	.2031	6"	2-7/16"	6	\$5.75
212SP1464	7/32"	.2188	6"	2-1/2"	6	\$6.06
212SP1564	15/64"	.2344	6"	2-5/8"	6	\$6.44
212SP1664	1/4"	.2500	6"	2-3/4"	6	\$7.50
212SP1764	17/64"	.2656	6"	2-7/8"	6	\$7.95
212SP1864	9/32"	.2812	6"	2-15/16"	6	\$8.65
212SP2064	5/16"	.3125	6"	3-3/16"	1	\$9.10
212SP2264	11/32"	.3438	6"	3-7/16"	1	\$11.72
212SP2464	3/8"	.3750	6"	3-5/8"	1	\$14.17
212SP2864	7/16"	.4375	6"	4-1/16"	1	\$17.56
212SP3264	1/2"	.5000	6"	4-1/2"	1	\$21.11

18" Aircraft - M2 HSS

Part #	Size	Dec.	OAL	Flute	Qty.	List
215SP1264	3/16"	.1875	18"	2-5/16"	1	\$17.13
215SP1664	1/4"	.2500	18"	2-3/4"	1	\$18.90
215SP2064	5/16"	.3125	18"	3-3/16"	1	\$33.50
215SP2464	3/8"	.3750	18"	3-5/8"	1	\$35.67
215SP3264	1/2"	.5000	18"	4-1/2"	1	\$49.47

6" Wire Gauge Aircraft - M2 HSS

Part #	Size	Dec.	OAL	Flute	Qty.	List
213SP0001	1	.2280	6"	2-5/8"	6	\$5.42
213SP0002	2	.2210	6"	2-5/8"	6	\$5.42
213SP0007	7	.2010	6"	2-7/16"	6	\$5.42
213SP0009	9	.1960	6"	2-7/16"	6	\$5.42
213SP0010	10	.1935	6"	2-7/16"	6	\$4.52
213SP0011	11	.1910	6"	2-5/16"	6	\$4.52
213SP0016	16	.1770	6"	2-3/16"	6	\$4.52
213SP0017	17	.1730	6"	2-3/16"	6	\$4.52
213SP0021	21	.1590	6"	2-1/8"	6	\$4.14
213SP0026	26	.1470	6"	1-7/8"	6	\$4.14
213SP0029	29	.1360	6"	1-3/4"	6	\$4.14
213SP0030	30	.1285	6"	1-5/8"	6	\$3.37
213SP0031	31	.1200	6"	1-5/8"	6	\$3.37
213SP0040	40	.0980	6"	1-3/8"	6	\$4.56

12" Wire Gauge Aircraft - M2 HSS

Part #	Size	Dec.	OAL	Flute	Qty.	List
213SP1201	1	.2280	12"	2-5/8"	1	\$16.32
213SP1207	7	.2010	12"	2-7/16"	1	\$12.53
213SP1210	10	.1935	12"	2-7/16"	1	\$12.53
213SP1221	21	.1590	12"	2-1/8"	1	\$9.53
213SP1229	29	.1360	12"	1-3/4"	1	\$6.36
213SP1230	30	.1285	12"	1-5/8"	1	\$6.36
213SP1231	31	.1200	12"	1-5/8"	1	\$6.36
213SP1240	40	.0980	12"	1-3/8"	1	\$6.91

- ◆ Straight Shank
- ◆ 135° Split Point
- ◆ Ground Flute
- ◆ Extra Flexibility
- ◆ Heavy Duty Web
- ◆ Black Oxide Finish
- ◆ M2 HSS

- Stainless Steel
- Medium Alloys

12" Aircraft - M2 HSS

Part #	Size	Dec.	OAL	Flute	Qty.	List
214SP0864	1/8"	.1250	12"	1-5/8"	1	\$6.33
214SP1064	5/32"	.1562	12"	2"	1	\$7.39
214SP1264	3/16"	.1875	12"	2-5/16"	1	\$11.67
214SP1464	7/32"	.2188	12"	2-1/2"	1	\$14.89
214SP1664	1/4"	.2500	12"	2-3/4"	1	\$16.33
214SP1864	9/32"	.2812	12"	2-15/16"	1	\$21.75
214SP2064	5/16"	.3125	12"	3-3/16"	1	\$23.39
214SP2264	11/32"	.3438	12"	3-7/16"	1	\$24.83
214SP2464	3/8"	.3750	12"	3-5/8"	1	\$26.94
214SP2864*	7/16"	.4375	12"	4-1/16"	1	\$35.83
214SP3264*	1/2"	.5000	12"	4-1/2"	1	\$43.39

* 3/8" Shank



Long Boy - Full Body Spiral Drills P. 50

MAIN OFFICE
 INTERNATIONAL TOOL MANUFACTURING
 71-08 51ST. AVENUE, WOODSIDE, NY 11377
 (718) 446-0711 - (800) 247-5696 - FAX (718) 899-6553



INTERNATIONAL TOOL MANUFACTURING
 675-E-PROGRESS CENTER AVE., LAWRENCEVILLE, GA 30043
 (770) 962-5454 - (800) 229-1776 - FAX (770) 962-5869

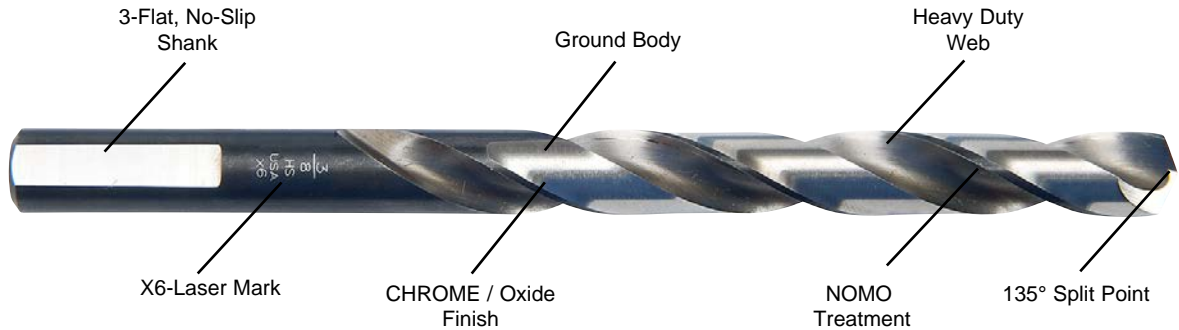

Made In



X6-CHROME

NOMO - Nitride On Margin Only - For Longer Cutting Edge Life & Lubricity



X6-CHROME Jobber Drills - SUPER HEAVY DUTY - NOMO

- ◆ Chrome / Oxide Finish
- ◆ 600° C Red-Heat Toughness
- ◆ NOMO Treatment
- ◆ 3-Flat Shanks (3/16" → 1/2")
- ◆ Heavy Duty Web for Strength & Rigidity
- ◆ M2 HSS

Part #	Size	Dec.	OAL	Flute	Qty.	List	Part #	Size	Dec.	OAL	Flute	Qty.	List
X6-0464	1/16"	.0625	1-7/8"	7/8"	12	\$2.17	X6-1964	19/64"	.2969	4-3/8"	3-1/16"	12	\$8.02
X6-0564	5/64"	.0781	2"	1"	12	\$2.24	X6-2064	5/16"	.3125	4-1/2"	3-3/16"	12	\$8.46
X6-0664	3/32"	.0938	2-1/4"	1-1/4"	12	\$2.53	X6-2164	21/64"	.3281	4-5/8"	3-5/16"	6	\$9.36
X6-0764	7/64"	.1094	2-5/8"	1-1/2"	12	\$2.80	X6-2264	11/32"	.3438	4-3/4"	3-7/16"	6	\$10.45
X6-0864	1/8"	.1250	2-3/4"	1-5/8"	12	\$2.82	X6-2364	23/64"	.3594	4-7/8"	3-1/2"	6	\$11.89
X6-0964	9/64"	.1406	2-7/8"	1-3/4"	12	\$2.92	X6-2464	3/8"	.3750	5"	3-5/8"	6	\$12.33
X6-1064	5/32"	.1562	3-1/8"	2"	12	\$2.92	X6-2564	25/64"	.3906	5-1/8"	3-3/4"	6	\$13.47
X6-1164	11/64"	.1719	3-1/4"	2-1/8"	12	\$3.11	X6-2664	13/32"	.4062	5-1/4"	3-7/8"	6	\$13.94
X6-1264	3/16"	.1875	3-1/2"	2-5/16"	12	\$4.18	X6-2764	27/64"	.4219	5-3/8"	3-15/16"	6	\$15.65
X6-1364	13/64"	.2031	3-5/8"	2-7/16"	12	\$4.47	X6-2864	7/16"	.4375	5-1/2"	4-1/16"	6	\$16.40
X6-1464	7/32"	.2188	3-3/4"	2-1/2"	12	\$5.06	X6-2964	29/64"	.4531	5-5/8"	4-3/16"	6	\$17.83
X6-1564	15/64"	.2344	3-7/8"	2-5/8"	12	\$5.40	X6-3064	15/32"	.4688	5-3/4"	4-5/16"	6	\$18.97
X6-1664	1/4"	.2500	4"	2-3/4"	12	\$5.59	X6-3164	31/64"	.4844	5-7/8"	4-3/8"	6	\$19.37
X6-1764	17/64"	.2656	4-1/8"	2-7/8"	12	\$6.85	X6-3264	1/2"	.5000	6"	4-1/2"	6	\$19.76
X6-1864	9/32"	.2812	4-1/4"	2-15/16"	12	\$7.58							

- Cast Iron
- Steel
- Steel Forging
- Stainless Steel

X6-CHROME Sets

Part #	Set	Case	Sizes	Type	List
X6-13	13 pc	Huot Metal Case	1/16" → 1/4" x 64ths	X6-Chrome 3-Flat	\$43.40
X6-15	15 pc	Huot Metal Case	1/16" → 1/2" x 32nds	X6-Chrome 3-Flat	\$111.70
X6-29	29 pc	Huot Metal Case	1/16" → 1/2" x 64ths	X6-Chrome 3-Flat	\$204.77
X6-1	29 pc	Bullet Case	1/16" → 1/2" x 64ths	X6-Chrome 3-Flat	\$256.65



All NEW Original Design

100% Made in USA.

Developed for the first time in 2013, the All New X6-Chrome Jobber Drill is designed specifically for the brutally demanding work conditions of New York City skyline contractors.

Whether under generator power or cordless / battery power, the X6-Chrome maintains supreme life-performance. NOMO treatment for superior Red-Heat (600° C) toughness.

3- Flats will not slip in your chuck.

MAIN OFFICE
 INTERNATIONAL TOOL MANUFACTURING
 71-08 51ST. AVENUE, WOODSIDE, NY 11377
 (718) 446-0711 - (800) 247-5696 - FAX (718) 899-6553



INTERNATIONAL TOOL MANUFACTURING
 675-E-PROGRESS CENTER AVE., LAWRENCEVILLE, GA 30043
 (770) 962-5454 - (800) 229-1776 - FAX (770) 962-5869



Parabolic Jobber Drills - SUPER HEAVY DUTY - M2 HSS

Part #	Size	Dec.	OAL	Flute	Qty.	List	Part #	Size	Dec.	OAL	Flute	Qty.	List
PB-0464	1/16"	.0625	1-7/8"	7/8"	12	\$2.01	PB-1964	19/64"	.2969	4-3/8"	3-1/16"	12	\$6.03
PB-0564	5/64"	.0781	2"	1"	12	\$2.01	PB-2064	5/16"	.3125	4-1/2"	3-3/16"	12	\$6.28
PB-0664	3/32"	.0938	2-1/4"	1-1/4"	12	\$2.01	PB-2164	21/64"	.3281	4-5/8"	3-5/16"	6	\$7.16
PB-0764	7/64"	.1094	2-5/8"	1-1/2"	12	\$2.21	PB-2264	11/32"	.3438	4-3/4"	3-7/16"	6	\$7.78
PB-0864	1/8"	.1250	2-3/4"	1-5/8"	12	\$2.21	PB-2364	23/64"	.3594	4-7/8"	3-1/2"	6	\$8.86
PB-0964	9/64"	.1406	2-7/8"	1-3/4"	12	\$2.32	PB-2464	3/8"	.3750	5"	3-5/8"	6	\$9.01
PB-1064	5/32"	.1562	3-1/8"	2"	12	\$2.32	PB-2564	25/64"	.3906	5-1/8"	3-3/4"	6	\$11.09
PB-1164	11/64"	.1719	3-1/4"	2-1/8"	12	\$2.47	PB-2664	13/32"	.4062	5-1/4"	3-7/8"	6	\$11.20
PB-1264	3/16"	.1875	3-1/2"	2-5/16"	12	\$2.73	PB-2764	27/64"	.4219	5-3/8"	3-15/16"	6	\$12.88
PB-1364	13/64"	.2031	3-5/8"	2-7/16"	12	\$2.99	PB-2864	7/16"	.4375	5-1/2"	4-1/16"	6	\$13.16
PB-1464	7/32"	.2188	3-3/4"	2-1/2"	12	\$3.55	PB-2964	29/64"	.4531	5-5/8"	4-3/16"	6	\$15.11
PB-1564	15/64"	.2344	3-7/8"	2-5/8"	12	\$3.86	PB-3064	15/32"	.4688	5-3/4"	4-5/16"	6	\$15.60
PB-1664	1/4"	.2500	4"	2-3/4"	12	\$3.97	PB-3164	31/64"	.4844	5-7/8"	4-3/8"	6	\$16.74
PB-1764	17/64"	.2656	4-1/8"	2-7/8"	12	\$4.94	PB-3264	1/2"	.5000	6"	4-1/2"	6	\$16.96
PB-1864	9/32"	.2812	4-1/4"	2-15/16"	12	\$5.61							



Black & Gold

- ◆ Jobber Length
- ◆ 135° Split Point
- ◆ Ground Flute
- ◆ Straight Shank
- ◆ Heavy Duty Web
- ◆ Black & Gold Finish
- ◆ M2 HSS

- Cast Iron
- Steel
- Steel Forging
- Stainless Steel

Extra Heavy Duty Web

30% thicker than even heavy duty webs, resists the extra shear stress found in deep hole drilling

Parabolic Flutes Faster

spiral allows deep hole drilling without frequent drill removal to clear chips



Cobalt Jobber Drills - SUPER HEAVY DUTY - M35 SUPER COBALT

Part #	Size	Dec.	OAL	Flute	Qty.	List	Part #	Size	Dec.	OAL	Flute	Qty.	List
CO-0464	1/16"	.0625	1-7/8"	7/8"	12	\$2.65	CO-1964	19/64"	.2969	4-3/8"	3-1/16"	12	\$9.85
CO-0564	5/64"	.0781	2"	1"	12	\$2.65	CO-2064	5/16"	.3125	4-1/2"	3-3/16"	12	\$10.11
CO-0664	3/32"	.0938	2-1/4"	1-1/4"	12	\$2.65	CO-2164	21/64"	.3281	4-5/8"	3-5/16"	6	\$11.80
CO-0764	7/64"	.1094	2-5/8"	1-1/2"	12	\$2.75	CO-2264	11/32"	.3438	4-3/4"	3-7/16"	6	\$12.90
CO-0864	1/8"	.1250	2-3/4"	1-5/8"	12	\$3.11	CO-2364	23/64"	.3594	4-7/8"	3-1/2"	6	\$12.95
CO-0964	9/64"	.1406	2-7/8"	1-3/4"	12	\$3.50	CO-2464	3/8"	.3750	5"	3-5/8"	6	\$13.00
CO-1064	5/32"	.1562	3-1/8"	2"	12	\$3.60	CO-2564	25/64"	.3906	5-1/8"	3-3/4"	6	\$15.60
CO-1164	11/64"	.1719	3-1/4"	2-1/8"	12	\$3.75	CO-2664	13/32"	.4062	5-1/4"	3-7/8"	6	\$17.55
CO-1264	3/16"	.1875	3-1/2"	2-5/16"	12	\$4.33	CO-2764	27/64"	.4219	5-3/8"	3-15/16"	6	\$19.80
CO-1364	13/64"	.2031	3-5/8"	2-7/16"	12	\$5.45	CO-2864	7/16"	.4375	5-1/2"	4-1/16"	6	\$20.25
CO-1464	7/32"	.2188	3-3/4"	2-1/2"	12	\$5.60	CO-2964	29/64"	.4531	5-5/8"	4-3/16"	6	\$23.20
CO-1564	15/64"	.2344	3-7/8"	2-5/8"	12	\$6.35	CO-3064	15/32"	.4688	5-3/4"	4-5/16"	6	\$23.85
CO-1664	1/4"	.2500	4"	2-3/4"	12	\$6.32	CO-3164	31/64"	.4844	5-7/8"	4-3/8"	6	\$25.35
CO-1764	17/64"	.2656	4-1/8"	2-7/8"	12	\$7.50	CO-3264	1/2"	.5000	6"	4-1/2"	6	\$25.60
CO-1864	9/32"	.2812	4-1/4"	2-15/16"	12	\$8.05							



- ◆ Jobber Length
- ◆ 135° Split Point
- ◆ Ground Flute
- ◆ Straight Shank
- ◆ Heavy Duty Web
- ◆ Gold Finish
- ◆ M35 Super Cobalt

- Hardened Steel
- Stainless Steel
- High Temp Alloys
- Heat Treated Materials
- Abrasive Plastics

MAIN OFFICE
 INTERNATIONAL TOOL MANUFACTURING
 71-08 51ST. AVENUE, WOODSIDE, NY 11377
 (718) 446-0711 - (800) 247-5696 - FAX (718) 899-6553



INTERNATIONAL TOOL MANUFACTURING
 675-E-PROGRESS CENTER AVE., LAWRENCEVILLE, GA 30043
 (770) 962-5454 - (800) 229-1776 - FAX (770) 962-5869

AMERICAN ORIGINAL



American Original Silver & Deming - 1/2" Shank - M2 HSS

- ◆ 6" Length
- ◆ 118° Point
- ◆ Ground Flute
- ◆ 3-Flat Round 1/2" Shank
- ◆ Gold Finish
- ◆ M35 Cobalt
- Cast Iron
- Steel
- Steel Forging
- Stainless Steel

Part #	Size	Dec.	OAL	Flute	Qty.	List	Part #	Size	Dec.	OAL	Flute	Qty.	List
AO-3364	33/64"	.5156	6	2-3/4"	1	\$29.02	AO-5364	53/64"	.8281	6	2-3/4"	1	\$52.58
AO-3464	17/32"	.5312	6	2-3/4"	1	\$28.12	AO-5464	27/32"	.8438	6	2-3/4"	1	\$52.79
AO-3564	35/64"	.5469	6	2-3/4"	1	\$31.08	AO-5564	55/64"	.8594	6	2-3/4"	1	\$54.10
AO-3664	9/16"	.5625	6	2-3/4"	1	\$31.08	AO-5664	7/8"	.8750	6	2-3/4"	1	\$55.62
AO-3764	37/64"	.5781	6	2-3/4"	1	\$32.48	AO-5764	57/64"	.8906	6	2-3/4"	1	\$58.75
AO-3864	19/32"	.5938	6	2-3/4"	1	\$35.11	AO-5864	29/32"	.9062	6	2-3/4"	1	\$59.04
AO-3964	39/64"	.6094	6	2-3/4"	1	\$36.84	AO-5964	59/64"	.9219	6	2-3/4"	1	\$59.36
AO-4064	5/8"	.6250	6	2-3/4"	1	\$34.49	AO-6064	15/16"	.9375	6	2-3/4"	1	\$63.35
AO-4164	41/64"	.6406	6	2-3/4"	1	\$37.66	AO-6164	61/64"	.9531	6	2-3/4"	1	\$66.48
AO-4264	21/32"	.6562	6	2-3/4"	1	\$38.11	AO-6264	31/32"	.9688	6	2-3/4"	1	\$72.81
AO-4364	43/64"	.6719	6	2-3/4"	1	\$40.33	AO-6364	63/64"	.9844	6	2-3/4"	1	\$74.82
AO-4464	11/16"	.6875	6	2-3/4"	1	\$38.52	AO-6464	1"	1.0000	6	2-3/4"	1	\$90.78
AO-4564	45/64"	.7031	6	2-3/4"	1	\$42.51	AO-6864	1-1/16"	1.0625	6	2-3/4"	1	\$106.19
AO-4664	23/32"	.7188	6	2-3/4"	1	\$43.54	AO-7265	1-1/8"	1.1250	6	2-3/4"	1	\$110.59
AO-4764	47/64"	.7344	6	2-3/4"	1	\$44.52	AO-7664	1-3/16"	1.1875	6	2-3/4"	1	\$117.82
AO-4864	3/4"	.7500	6	2-3/4"	1	\$43.21	AO-8064	1-1/4"	1.2500	6	2-3/4"	1	\$135.42
AO-4964	49/64"	.7656	6	2-3/4"	1	\$46.04	AO-8465	1-5/16"	1.3125	6	2-3/4"	1	\$153.63
AO-5064	25/32"	.7812	6	2-3/4"	1	\$47.94	AO-8864	1-3/8"	1.3750	6	2-3/4"	1	\$169.42
AO-5164	51/64"	.7969	6	2-3/4"	1	\$47.94	AO-9664	1-1/2"	1.5000	6	2-3/4"	1	\$203.25
AO-5264	13/16"	.8125	6	2-3/4"	1	\$48.51							



29 PC Jobber Sets - Bullet Case - USA

Part #	Set	Sizes	Type	Drills	Point	List
X6-1	29 pc	1/16" → 1/2" x 64ths	X6-CHROME 3-FLAT	p. 24	135° S.P.	\$256.55
PB-1	29 pc	1/16" → 1/2" x 64ths	PARABOLIC	p. 25	135° S.P.	\$203.08
CO-1	29 pc	1/16" → 1/2" x 64ths	COBALT	p. 25	135° S.P.	\$310.07

S.P. = Split Point

MAIN OFFICE
 INTERNATIONAL TOOL MANUFACTURING
 71-08 51ST. AVENUE, WOODSIDE, NY 11377
 (718) 446-0711 - (800) 247-5696 - FAX (718) 899-6553



INTERNATIONAL TOOL MANUFACTURING
 675-E-PROGRESS CENTER AVE., LAWRENCEVILLE, GA 30043
 (770) 962-5454 - (800) 229-1776 - FAX (770) 962-5869

29 PC Jobber Sets - Bullet Case

Part #	Set	Sizes	Type	Drills	Point	List
MC-1	29 pc	1/16" → 1/2" x 64ths	MECHANICS	p. 18	135° S.P.	\$158.63
BG-1	29 pc	1/16" → 1/2" x 64ths	BLACK & GOLD	p. 17	135° S.P.	\$138.14
BX-1	29 pc	1/16" → 1/2" x 64ths	BLACK OXIDE	p. 12	135° S.P.	\$120.89
CX-1	29 pc	1/16" → 1/2" x 64ths	COBALT	p. 20	135° S.P.	\$229.88
TI-1	29 pc	1/16" → 1/2" x 64ths	TITANIUM	p. 22	135° S.P.	\$209.60
BT-1	29 pc	1/16" → 1/2" x 64ths	BRITE	p. 10	118°	\$138.54

S.P. = Split Point



Made In



Mechanics
 Black & Gold
 MC-1



Black & Gold
 BG-1



Black Oxide
 BX-1



Cobalt
 CX-1



Titanium
 TI-1



Brite
 BT-1



13 PC Jobber Sets - Straight Shank

Part #	Set	Sizes	Type	Drills	Point	List
AD-13	13 pc	1/16" → 1/4" x 64ths	Black Oxide	p.11	118°	\$15.45
BT-13	13 pc	1/16" → 1/4" x 64ths	Bright Finish	p.10	118°	\$23.47
SP-13	13 pc	1/16" → 1/4" x 64ths	Black Oxide	p.12	135° S.P.	\$22.39
BG-13	13 pc	1/16" → 1/4" x 64ths	Black & Gold	p.17	135° S.P.	\$29.03
CX-13	13 pc	1/16" → 1/4" x 64ths	Cobalt	p.20	135° S.P.	\$39.64
CO-13	13 pc	1/16" → 1/4" x 64ths	Cobalt* (USA)	p.25	135° S.P.	\$43.40
TI-13	13 pc	1/16" → 1/4" x 64ths	Titanium	p.22	135° S.P.	\$45.42
X6-13	13 pc	1/16" → 1/4" x 64ths	X6-Chrome*	p.24	135° S.P.	\$43.40
PB-13	13 pc	1/16" → 1/4" x 64ths	Parabolic*	p.25	135° S.P.	\$33.76

◆ Metal Huot Case

* Made in USA

S.P. = Split Point



15 PC Jobber Sets - Straight Shank

Part #	Set	Sizes	Type	Drills	Point	List
SP-15	15 pc	1/16" → 1/2" x 32nds	Black Oxide	p.12	135° S.P.	\$60.84
BG-15	15 pc	1/16" → 1/2" x 32nds	Black & Gold	p.17	135° S.P.	\$80.05
CX-15	15 pc	1/16" → 1/2" x 32nds	Cobalt	p.20	135° S.P.	\$127.95
CO-15	15 pc	1/16" → 1/2" x 32nds	Cobalt* (USA)	p.25	135° S.P.	\$136.58
X6-15	15 pc	1/16" → 1/2" x 32nds	X6-Chrome*	p.24	135° S.P.	\$111.70
PB-15	15 pc	1/16" → 1/2" x 32nds	Parabolic*	p.25	135° S.P.	\$92.11

◆ Metal Huot Case

* Made in USA

S.P. = Split Point



29 PC Jobber Sets - Straight Shank

Part #	Set	Sizes	Type	Drills	Point	List
AD-29	29 pc	1/16" → 1/2" x 64ths	Black Oxide	p.11	118°	\$75.60
BT-29	29 pc	1/16" → 1/2" x 64ths	Bright Finish	p.10	118°	\$133.17
SP-29	29 pc	1/16" → 1/2" x 64ths	Black Oxide	p.12	135° S.P.	\$120.89
BG-29	29 pc	1/16" → 1/2" x 64ths	Black & Gold	p.17	135° S.P.	\$158.14
CX-29	29 pc	1/16" → 1/2" x 64ths	Cobalt	p.20	135° S.P.	\$238.88
CO-29	29 pc	1/16" → 1/2" x 64ths	Cobalt* (USA)	p.25	135° S.P.	\$257.26
TI-29	29 pc	1/16" → 1/2" x 64ths	Titanium	p.22	135° S.P.	\$259.60
X6-29	29 pc	1/16" → 1/2" x 64ths	X6-Chrome*	p.24	135° S.P.	\$204.77
PB-29	29 pc	1/16" → 1/2" x 64ths	Parabolic*	p.25	135° S.P.	\$155.83

◆ Metal Huot Case

* Made in USA

S.P. = Split Point



29 PC Jobber Sets - 3/8" Shank

Part #	Set	Sizes	Type	Drills	Point	List
SP-29R	29 pc	1/16" → 1/2" x 64ths	Black Oxide	p.13	135° S.P.	\$157.81
BG-29R	29 pc	1/16" → 1/2" x 64ths	Black & Gold	p.18	135° S.P.	\$178.25
CX-29R	29 pc	1/16" → 1/2" x 64ths	Cobalt	p.21	135° S.P.	\$269.62

1/16" - 3/8" STRAIGHT SHANK, 25/64" - 1/2" WITH 3/8" SHANK

S.P. = Split Point

◆ Metal Huot Case



8 PC Silver & Deming Sets

Part #	Set	Sizes	Type	Drills	Point	List
AD-8	8 pc	See Below	Black Oxide	p.15	118°	\$185.21
BG-8	8 pc	See Below	Black & Gold	p.19	118°	\$251.40
CX-8	8 pc	See Below	Cobalt	p.21	135° S.P.	\$515.06
AO-8	8 pc	See Below	American Original*	p.26	135° S.P.	\$371.98

ALL SETS: 9/16", 5/8", 11/16", 3/4", 13/16", 7/8", 15/16", 1"

S.P. = Split Point

* Made in USA

◆ Metal Huot Case



60 PC Wire Gauge Sets

Part #	Set	Sizes	Type	Drills	Point	List
SP-60	60 pc	#1 → #60	Black Oxide	p.12	135° S.P.	\$87.64
BG-60	60 pc	#1 → #60	Black & Gold	p.17	135° S.P.	\$93.37
CX-60	60 pc	#1 → #60	Cobalt	p.20	135° S.P.	\$189.27

S.P. = Split Point

◆ Metal Huot Case





LETTER A → Z Sets - Straight Shank

Part #	Set	Sizes	Type	Drills	Point	List
SP-AZ	26 pc	A → Z	Black Oxide	p.13	135° S.P.	\$146.96
BG-AZ	26 pc	A → Z	Black & Gold	p.19	135° S.P.	\$157.02

◆ Metal Huot Case

S.P. = Split Point

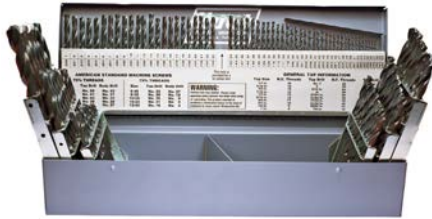

115 PC MASTER Sets - Straight Shank

Part #	Set	Sizes	Type	Drills	Point	List
SP-115	115 pc	See Below	Black Oxide	p.12	135° S.P.	\$366.00
BG-115	115 pc	See Below	Black & Gold	p.17	135° S.P.	\$419.04
CX-115	115 pc	See Below	Cobalt	p.20	135° S.P.	\$710.44

JOBBER SIZES: 1/16" → 1/2", WIRE GAUGE DRILL SIZES #1 → #60,
 LETTER SIZES: A → Z. STRAIGHT SHANK.

◆ Metal Huot Case

S.P. = Split Point



METRIC Sets - Straight Shank

Part #	Set	Sizes	Type	Drills	Point	List
MM-11	11 pc	1.00MM → 6.00MM	Black Oxide	p.13	118°	\$23.85
MM-25	25 pc	1.00MM → 13.00MM	Black Oxide	p.13	118°	\$118.59

◆ Metal Huot Case



TAP & DRILL Sets - CARBON / HSS TAPS

Part #	Sizes	Type	Drills	Point	List
CD-SP-019	See Below	Carbon Taps	p.11	118°	\$56.71
TD-SP-019	See Below	HSS Taps	p.12	135° S.P.	\$79.54

HSS DRILL BIT SIZES: #36, #29, #25, #21, #7, F, 5/16", U, 27/64"
 TAP SIZES: 6-32, 8-32, 10-24, 10-32, 1/4"-20, 5/16"-18, 3/8"-16, 7/16"-14, 1/2"-13

◆ Metal Huot Case

MAIN OFFICE
 INTERNATIONAL TOOL MANUFACTURING
 71-08 51ST. AVENUE, WOODSIDE, NY 11377
 (718) 446-0711 - (800) 247-5696 - FAX (718) 899-6553



INTERNATIONAL TOOL MANUFACTURING
 675-E-PROGRESS CENTER AVE., LAWRENCEVILLE, GA 30043
 (770) 962-5454 - (800) 229-1776 - FAX (770) 962-5869

525 Pc. Dispenser Contains:

24- 1/16"	24- 5/64"	48- 3/32"	24- 7/64"	72- 1/8"
24- 9/64"	36- 5/32"	24- 11/64"	48- 3/16"	24- 13/64"
24- 7/32"	12- 15/64"	60- 1/4"	3- 17/64"	12- 9/32"
3- 19/64"	12- 5/16"	3- 21/64"	3- 11/32"	3- 23/64"
12- 3/8"	3- 25/64"	3- 13/32"	3- 27/64"	6- 7/16"
3- 29/64"	3- 15/32"	3- 31/64"	6- 1/2"	

This attractive drill bit merchandiser puts all 29 essential jobber sizes at your fingertips. Made of heavy duty steel construction, this deep red cabinet dispenser fits perfectly on any counter top. Comes with lock and key.



525 PC Jobber Countertop Dispenser

Part #	Set	Sizes	Type	Drills	Point	List
SP-525	525 pc	1/16" → 1/2" x 64ths	Black Oxide	p.12	135° S.P.	\$1040.86
BG-525	525 pc	1/16" → 1/2" x 64ths	Black & Gold	p.17	135° S.P.	\$1498.34
CX-525	525 pc	1/16" → 1/2" x 64ths	Cobalt	p.20	135° S.P.	\$1950.98
X6-525	525 pc	1/16" → 1/2" x 64ths	X6-Chrome*	p.24	135° S.P.	\$2251.69

◆ Metal Huot Case

* Made in USA

S.P. = Split Point

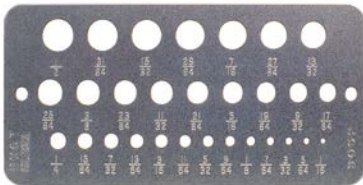



Metal Drill Gauges

Part #	Description	Sizes	List
29GAUGE	29 Hole Gauge	1/16" → 1/2"	\$12.05
60GAUGE	60 Hole Gauge	#1 → #60 Wire	\$14.34







TAPER



8 to 10 threads chamfered for easy thread starting in tough material.

PLUG

3 to 5 threads chamfered for general use when tapping to bottom of hole is not critical. **This is the most popular tap of all three styles.**

BOTTOM

1-1/2 threads chamfered for use after threads have been started. Used for clean tapping to bottom of holes.

NC = National Course
NF = National Fine



Packaging:
Sizes
 0-80 → 1/2"-20
 5 / box

Sold Individually
 over 1/2"-20.

DRILL THIS SIZE HOLE			TO TAP FOR THIS BOLT OR SCREW
DECIMAL INCHES	DRILL SIZE	NEAREST FRACTION	
.0469"	3/64"	3/64"	0-80 NF
.0595"	No. 53	none	1-64 NC
.0595"	No. 53	1/16"	1-72 NF
.0700"	No. 50	none	2-56 NC
.0700"	No. 50	none	2-64 NF
.0785"	No. 47	5/64"	3-48 NC
.0820"	No. 45	none	3-56 NF
.0860"	No. 44	none	4-36 NS
.0890"	No. 43	3/32"	4-40 NC
.0935"	No. 42	3/32"	4-48 NF
.0984"	2.5mm	none	3mm-0.60mm
.1015"	No. 38	none	1/8-40 NS
.1015"	No. 38	none	5-40 NC
.1040"	No. 37	none	5-44 NF
.1100"	No. 35	7/64"	6-32 NC
.1110"	No. 34	none	6-36 NS
.1130"	No. 33	none	6-40 NF
.1200"	No. 31	none	6-48 NS
.1338"	3.4mm	none	4mm-0.70mm
.1338"	3.4mm	none	4mm-0.75mm
.1360"	No. 29	none	8-32 NC
.1360"	No. 29	9/64"	8-36 NF
.1405"	No. 28	none	8-40 NS
.1470"	No. 26	none	3/16-24 NS
.1495"	No. 25	5/32"	10-24 NC
.1570"	No. 22	none	3/16-32 NS
.1590"	No. 21	5/32"	10-32 NF
.1653"	4.2mm	none	5mm-0.90mm
.1693"	4.3mm	none	5mm-0.80mm
.1770"	No. 16	11/64"	12-24 NC
.1820"	No. 14	3/16"	12-28 NF
.1850"	No. 13	none	12-32 NEF
.1935"	No. 10	none	14-20 NS
.2010"	No. 7	13/64"	1/4-20 NC
.2010"	No. 7	none	14-24 NS
.2047"	5.2mm	none	6mm-1.00mm
.2090"	No. 4	none	1/4-24 NS
.2130"	No. 3	7/32"	1/4-28 NF
.2188"	7/32"	7/32"	1/4-32 NEF
.2280"	No. 1	none	1/4-40 NS
.2401"	6.1mm	15/64"	7mm-1.00mm
.2570"	Ltr. F	17/64"	5/16-18 NC
.2716"	6.9mm	17/64"	8mm-1.25mm
.2720"	Ltr. I	none	5/16-24 NF
.2795"	7.1mm	none	8mm-1.00mm
.2812"	9/32"	9/32"	5/16-32 NEF
.3110"	7.9mm	none	9mm-1.25mm
.3125"	5/16"	5/16"	3/8-16 NC

DRILL THIS SIZE HOLE			TO TAP FOR THIS BOLT OR SCREW
DECIMAL INCHES	DRILL SIZE	NEAREST FRACTION	
.3189"	8.1mm	none	9mm-1.00mm
.3268"	8.3mm	none	9mm-0.75mm
.3320"	Ltr. Q	21/64"	3/8-24 NF
.3425"	8.7mm	none	10mm-1.50mm
.3503"	8.9mm	11/32"	10mm-1.25mm
.3583"	9.1mm	none	*10mm-1.00mm
.3680"	Ltr. U	23/64"	7/16"-14 NC
.3818"	9.7mm	none	11mm-1.50mm
.3906"	25/64"	25/64"	7/16-20 NF
.4133"	10.5mm	none	12mm-1.75mm
.4212"	10.7mm	27/64"	12mm-1.50mm
.4219"	27/64"	27/64"	1/2-13 NC
.4291"	10.9mm	27/64"	*12mm-1.25mm
.4531"	29/64"	29/64"	1/2-20 NF
.4531"	29/64"	29/64"	1/2-24 NS
.4803"	12.2mm	none	14mm-2.00mm
.4844"	31/64"	31/64"	9/16-12 NC
.4999"	12.7mm	none	14mm-1.50mm
.5039"	12.8mm	none	*14mm-1.25mm
.5156"	33/64"	33/64"	9/16-18 NF
.5312"	17/32"	17/32"	5/8-11 NC
.5590"	14.2mm	35/64"	16mm-2.00mm
.5781"	37/64"	37/64"	5/8-18 NF
.5787"	14.7mm	none	16mm-1.50mm
.5938"	19/32"	19/32"	11/16-11 NS
.6220"	15.8mm	39/64"	18mm-2.50mm
.6250"	5/8"	5/8"	11/16-16 NS
.6562"	21/32"	21/32"	3/4-10 NC
.6614"	16.8mm	none	*18mm-1.50mm
.6875"	11/16"	11/16"	3/4-16 NF
.7008"	17.8mm	11/16"	20mm-2.50mm
.7656"	49/64"	49/64"	7/8-9 NC
.8125"	13/16"	13/16"	7/8-14 NF
.8228"	20.9mm	none	22mm-1.50mm
.8281"	53/64"	53/64"	*7/8-18 NS
.8425"	21.4mm	53/64"	24mm-3.00mm
.8750"	7/8"	7/8"	1-8 NC
.8779"	22.3mm	none	24mm-2.00mm
.9219"	59/64"	59/64"	1-12 NF
.9375"	15/16"	15/16"	1-14 NS
.9844"	63/64"	63/64"	1-1/8 - 7 NC
1.0469"	1-3/64"	1-3/64"	1-1/8 - 12 NF
1.1094"	1-7/64"	1-7/64"	1-1/4 - 7 NC
1.1719"	1-11/64"	1-11/64"	1-1/4 - 12 NF
1.2188"	1-7/32"	1-7/32"	1-3/8 - 6 NC
1.2969"	1-19/64"	1-19/64"	1-3/8 - 12 NF
1.3468"	1-11/32"	1-11/32"	1-1/2 - 6 NC
1.4219"	1-27/64"	1-27/64"	1-1/2 - 12 NF

* Spark Plug Taps.



Carbon Steel Hand Taps - MACHINE SCREW

PART #			Machine Screw Thread	No. Of Flutes	Ground Thread Limit	O/A	Use Thread Length	Drill Size	List
TAPER	PLUG	BOTTOM							
C62NC0004	C63NC0004	C64NC0004	4-40 NC	3	H2	1-7/8"	9/16"	43	\$2.05
C62NF0004	C63NF0004	C62NF0004	4-48 NF	3	H2	1-7/8"	9/16"	42	\$2.05
C62NC0005	C63NC0005	C64NC0005	5-40 NC	3	H2	1-15/16"	7/8"	38	\$2.05
C62NF0005	C63NF0005	C64NF0005	5-44 NF	3	H2	1-15/16"	7/8"	37	\$2.05
C62NC0006	C63NC0006	C64NC0006	6-32 NC	3	H2	2"	11/16"	35	\$2.05
C62NF0006	C63NF0006	C64NF0006	6-40 NF	3	H2	2"	11/16"	33	\$2.05
C62NC0008	C63NC0008	C64NC0008	8-32 NC	4	H3	2-1/8"	3/4"	29	\$2.14
C62NF0008	C63NF0008	C64NF0008	8-36 NF	4	H3	2-1/8"	3/4"	29	\$2.14
C62NC0010	C63NC0010	C64NC0010	10-24 NC	4	H3	2-3/8"	7/8"	25	\$2.27
C62NF0010	C63NF0010	C64NF0010	10-32 NF	4	H3	2-3/8"	7/8"	21	\$2.27
C62NC0012	C63NC0012	C64NC0012	12-24 NC	4	H3	2-3/8"	15/16"	16	\$3.40
C62NF0012	C63NF0012	C64NF0012	12-28 NF	4	H3	2-3/8"	15/16"	14	\$3.40

Carbon Steel Hand Taps - FRACTIONAL

PART #			Machine Screw Thread	No. Of Flutes	Ground Thread Limit	O/A	Use Thread Length	Drill Size	List
TAPER	PLUG	BOTTOM							
C65NC0310	C66NC0310	C67NC0310	1/4"-20 NC	4	H3	2-1/2"	1"	7	\$2.36
C65NF0312	C66NF0312	C67NF0312	1/4"-28 NF	4	H3	2-1/2"	1"	3	\$2.36
C65NC0315	C66NC0315	C67NC0315	5/16"-18 NC	4	H3	2-23/32"	1-1/8"	F	\$3.08
C65NF0316	C66NF0316	C67NF0316	5/16"-24 NF	4	H3	2-23/32"	1-1/8"	I	\$3.08
C65NC0318	C66NC0318	C67NC0318	3/8"-16 NC	4	H3	2-15/16"	1-1/4"	5/16"	\$3.83
C65NF0319	C66NF0319	C67NF0319	3/8"-24 NF	4	H3	2-15/16"	1-1/4"	Q	\$3.83
C65NC0320	C66NC0320	C67NC0320	7/16"-14 NC	4	H3	3-5/32"	1-7/16"	U	\$4.34
C65NF0321	C66NF0321	C67NF0321	7/16"-20 NF	4	H3	3-5/32"	1-7/16"	25/64"	\$4.34
C65NC0322	C66NC0322	C67NC0322	1/2"-13 NC	4	H3	3-3/8"	1-21/32"	27/64"	\$5.79
C65NF0323	C66NF0323	C67NF0323	1/2"-20 NF	4	H3	3-3/8"	1-21/32"	29/64"	\$5.79
C65NC0325	C66NC0325	C67NC0325	9/16"-12 NC	4	H3	3-19/32"	1-21/32"	31/64"	\$7.20
C65NF0326	C66NF0326	C67NF0326	9/16"-18 NF	4	H3	3-19/32"	1-21/32"	33/64"	\$7.20
C65NC0327	C66NC0327	C67NC0327	5/8"-11 NC	4	H3	3-13/16"	1-13/16"	17/32"	\$9.24
C65NF0328	C66NF0328	C67NF0328	5/8"-18 NF	4	H3	3-13/16"	1-13/16"	37/64"	\$9.24
C65NC0331	C66NC0331	C67NC0331	3/4"-10 NC	4	H3	4-1/4"	2"	21/32"	\$10.88
C65NF0332	C66NF0332	C67NF0332	3/4"-16 NF	4	H3	4-1/4"	2"	11/16"	\$10.88
C65NC0333	C66NC0333	C67NC0333	7/8"-9 NC	4	H4	4-11/16"	2-7/32"	49/64"	\$16.60
C65NF0334	C66NF0334	C67NF0334	7/8"-14 NF	4	H4	4-11/16"	2-7/32"	13/16"	\$16.60
C65NC0335	C66NC0335	C67NC0335	1-8 NC	4	H4	5-1/8"	2-1/2"	7/8"	\$20.96
C65NF0336	C66NF0336	C67NF0336	1-12 NF	4	H4	5-1/8"	2-1/2"	59/64"	\$20.96
C65NC0337	C66NC0337	C67NC0337	1-14 NS	4	H4	5-1/8"	2-1/2"	15/16"	\$20.96
C65NC0338	C66NC0338	C67NC0338	1-1/8"- 7 NC	4	H4	5-7/16"	2-9/16"	63/64"	\$37.18



5 PCS. PER
 PACK FROM
 4-40 TO
 1/2"-20.
 SOLD
 1 PC.
 OVER 1/2"-20.



(HSS) High Speed Steel Hand Taps - MACHINE SCREW GROUND THREAD

PART #			Machine Screw Thread	No. Of Flutes	Ground Thread Limit	O/A	Use Thread Length	Drill Size	List
TAPER	PLUG	BOTTOM							
262NC0004	263NC0004	264NC0004	4-40 NC	3	H2	1-7/8"	9/16"	43	\$5.00
262NF0004	263NF0004	264NF0004	4-48 NF	3	H2	1-7/8"	9/16"	42	\$5.00
262NC0005	263NC0005	264NC0005	5-40 NC	3	H2	1-15/16"	7/8"	38	\$5.00
262NF0005	263NF0005	264NF0005	5-44 NF	3	H2	1-15/16"	7/8"	37	\$5.00
262NC0006	263NC0006	264NC0006	6-32 NC	3	H2	2"	11/16"	35	\$4.09
262NF0006	263NF0006	264NF0006	6-40 NF	3	H2	2"	11/16"	33	\$4.09
262NC0008	263NC0008	264NC0008	8-32 NC	4	H3	2-1/8"	3/4"	29	\$4.24
262NF0008	263NF0008	264NF0008	8-36 NF	4	H3	2-1/8"	3/4"	29	\$4.24
262NC0010	263NC0010	264NC0010	10-24 NC	4	H3	2-3/8"	7/8"	25	\$4.41
262NF0010	263NF0010	264NF0010	10-32 NF	4	H3	2-3/8"	7/8"	21	\$4.41
262NC0012	263NC0012	264NC0012	12-24 NC	4	H3	2-3/8"	15/16"	16	\$4.69
262NF0012	263NF0012	264NF0012	12-28 NF	4	H3	2-3/8"	15/16"	14	\$4.69



(HSS) High Speed Steel Hand Taps - FRACTIONAL GROUND THREAD

PART #			Machine Screw Thread	No. Of Flutes	Ground Thread Limit	O/A	Use Thread Length	Drill Size	List
TAPER	PLUG	BOTTOM							
265NC0310	266NC0310	267NC0310	1/4"-20 NC	4	H3	2-1/2"	1"	7	\$4.92
265NF0312	266NF0312	267NF0312	1/4"-28 NF	4	H3	2-1/2"	1"	3	\$4.92
265NC0315	266NC0315	267NC0315	5/16"-18 NC	4	H3	2-23/32"	1-1/8"	F	\$5.80
265NF0316	266NF0316	267NF0316	5/16"-24 NF	4	H3	2-23/32"	1-1/8"	I	\$5.80
265NC0318	266NC0318	267NC0318	3/8"-16 NC	4	H3	2-15/16"	1-1/4"	5/16"	\$6.80
265NF0319	266NF0319	267NF0319	3/8"-24 NF	4	H3	2-15/16"	1-1/4"	Q	\$6.80
265NC0320	266NC0320	267NC0320	7/16"-14 NC	4	H3	3-5/32"	1-7/16"	U	\$10.52
265NF0321	266NF0321	267NF0321	7/16"-20 NF	4	H3	3-5/32"	1-7/16"	25/64"	\$10.52
265NC0322	266NC0322	267NC0322	1/2"-13 NC	4	H3	3-3/8"	1-21/32"	27/64"	\$12.49
265NF0323	266NF0323	267NF0323	1/2"-20 NF	4	H3	3-3/8"	1-21/32"	29/64"	\$12.49
265NC0325	266NC0325	267NC0325	9/16"-12 NC	4	H3	3-19/32"	1-21/32"	31/64"	\$14.76
265NF0326	266NF0326	267NF0326	9/16"-18 NF	4	H3	3-19/32"	1-21/32"	33/64"	\$14.76
265NC0327	266NC0327	267NC0327	5/8"-11 NC	4	H3	3-13/16"	1-13/16"	17/32"	\$17.42
265NF0328	266NF0328	267NF0328	5/8"-18 NF	4	H3	3-13/16"	1-13/16"	37/64"	\$17.42
265NS0329	266NS0329	267NS0329	11/16"-11 NS	4	H3	4-1/32"	1-13/16"	19/32"	\$18.79
265NS0330	266NS0330	267NS0330	11/16"-16 NS	4	H3	4-1/32"	1-13/16"	5/8"	\$18.79
265NC0331	266NC0331	267NC0331	3/4"-10 NC	4	H3	4-1/4"	2"	21/32"	\$27.79
265NF0332	266NF0332	267NF0332	3/4"-16 NF	4	H3	4-1/4"	2"	11/16"	\$27.79
265NC0333	266NC0333	267NC0333	7/8"-9 NC	4	H4	4-11/16"	2-7/32"	49/64"	\$35.54
265NF0334	266NF0334	267NF0334	7/8"-14 NF	4	H4	4-11/16"	2-7/32"	13/16"	\$35.54
265NC0335	266NC0335	267NC0335	1-8 NC	4	H4	5-1/8"	2-1/2"	7/8"	\$47.84
265NF0336	266NF0336	267NF0336	1-12 NF	4	H4	5-1/8"	2-1/2"	59/64"	\$47.84
265NC0337	266NC0337	267NC0337	1-14 NS	4	H4	5-1/8"	2-1/2"	15/16"	\$47.84



5 PCS. PER
PACK FROM
4-40 TO
1/2"-20.
SOLD
1 PC.
OVER 1/2"-20.



- ◆ National Pipe Tap
- ◆ High Speed Steel
- ◆ Ground Thread
- ◆ Heavy Duty

**SOLD INDIVIDUALLY
 IN PLASTIC BOXES**



(HSS) NPT Taper Pipe Taps

Part #	Size	Threads Per Inch NPT Only	No. Of Flutes	O/A	Thread Length	List
265TP0464	1/16"	27	4	2-1/8"	11/16"	\$13.13
265TP0864	1/8"	27	4	2-1/8"	3/4"	\$13.13
265TP1664	1/4"	18	4	2-7/16"	1-1/16"	\$14.71
265TP2464	3/8"	18	4	2-9/16"	1-1/16"	\$19.10
265TP3264	1/2"	14	4	3-1/8"	1-3/8"	\$30.59
265TP4864	3/4"	14	5	3-1/4"	1-3/8"	\$47.53
265TP6464	1"	11.5	5	3-3/4"	1-3/4"	\$72.17
265TP8064	1-1/4"	11.5	5	4"	1-3/4"	\$102.83
265TP9664	1-1/2"	11.5	7	4-1/4"	1-3/4"	\$137.94
265TP9964	2"	11.5	7	4-1/2"	1-3/4"	\$187.96

- ◆ National Pipe Tap
- ◆ Carbon Steel
- ◆ Ground Thread
- ◆ General Purpose

**SOLD INDIVIDUALLY
 IN PLASTIC BOXES**



(Carbon Steel) NPT Taper Pipe Taps

Part #	Size	Threads Per Inch NPT Only	No. Of Flutes	O/A	Thread Length	List
NPT0464	1/16"	27	4	2-1/8"	11/16"	\$6.25
NPT0864	1/8"	27	4	2-1/8"	3/4"	\$6.25
NPT1664	1/4"	18	4	2-7/16"	1-1/16"	\$7.42
NPT2464	3/8"	18	4	2-9/16"	1-1/16"	\$9.90
NPT3264	1/2"	14	4	3-1/8"	1-3/8"	\$17.31
NPT4864	3/4"	14	5	3-1/4"	1-3/8"	\$24.18
NPT6464	1"	11.5"	5	3-3/4"	1-3/4"	\$41.75
NPT8864	1-1/4"	11.5"	5	4"	1-3/4"	\$57.98
NPT9664	1-1/2"	11.5"	7	4-1/4"	1-3/4"	\$76.07
NPT9964	2"	11.5"	7	4-1/2"	1-3/4"	\$119.03

NPT TAP-DRILL CHART



DRILL THIS SIZE HOLE			TO TAP FOR THIS BOLT OR SCREW
DECIMAL INCHES	DRILL SIZE	NEAREST FRACTION	
.3390"	Ltr. R	none	1/8-27 NPT
.4375"	7/16"	7/16"	1/4-18 NPT
.5781"	37/64"	37/64"	3/8- 8 NPT
.7031"	45/64"	45/64"	1/2-14 NPT
.9219"	59/64"	59/64"	3/4-14 NPT
1.1562"	1-5/32"	1-5/32"	1 - 11-1/2 NPT
1.5000"	1-1/2"	1-1/2"	1-1/4 - 11-1/2 NPT
1.7344"	1-47/64"	1-47/64"	1-1/2 - 11-1/2 NPT
2.2188"	2-7/32"	2-7/32"	2 - 11-1/2 NPT

Combo Drill Taps - HSS

Part #	Thread Size	Drill Size	Thread Length	O/A	List
266TD0632	6-32	0.1095	11/16"	2"	\$18.33
266TD0832	8-32	0.1360	3/4"	2-1/8"	\$18.72
266TD0836	8-36	0.1360	3/4"	2-1/8"	\$18.80
266TD1024	10-24	0.1520	7/8"	2-3/8"	\$19.43
266TD1032	10-32	0.1520	7/8"	2-3/8"	\$19.43
266TD1224	12-24	0.1770	15/16"	2-3/8"	\$20.42
267TD1420	1/4"-20	0.2010	15/16"	2-1/2"	\$22.70
267TD1428	1/4"-28	0.2010	15/16"	2-1/2"	\$22.70
267TD5618	5/16"-18	0.2570	1-1/8"	3"	\$27.26
267TD3816	3/8"-16	0.3125	1-1/4"	3-1/2"	\$31.73
267TD3824	3/8"-24	0.3125	1-1/4"	3-1/2"	\$31.73
267TD7614	7/16"-14	0.3680	1-7/16"	3-7/8"	\$37.68
267TD1213	1/2"-13	0.4250	1-21/32"	4-1/4"	\$44.54



- ◆ High Speed Steel
- ◆ Ground Thread
- ◆ Heavy Duty

Drill and Tap holes in one operation, saving a complete set-up!

**SOLD INDIVIDUALLY
IN PLASTIC BOXES**



Spiral Point (Gun) Taps - HSS

Part #	Size	No. Of Flutes	O/A	Thread Length	Drill Size	List
265SP0632	6-32	2	2"	11/16"	35	\$5.52
265SP0832	8-32	2	2-1/8"	3/4"	29	\$5.52
265SP1024	10-24	2	2-3/8"	7/8"	25	\$5.77
265SP1032	10-32	2	2-3/8"	7/8"	25	\$5.77
265SP1224	12-24	2	2-3/8"	15/16"	16	\$6.02
265SP1420	1/4"-20	2	2-1/2"	1"	7	\$5.39
265SP1428	1/4"-28	2	2-1/2"	1"	7	\$4.28
265SP5618	5/16"-18	2	2-23/32"	1-1/8"	F	\$5.77
265SP3816	3/8"-16	3	2-15/16"	1-1/4"	5/16"	\$7.16
265SP1312	1/2"-13	3	3-3/8"	1-21/32"	27/64"	\$12.15

- ◆ High Speed Steel
- ◆ Ground Thread
- ◆ Heavy Duty

Spiral Point Taps are ideal for machine tapping through holes or blind holes with adequate bottom clearance.



**Sold
5/Pack**



T-Handle Tap Wrench

Part #	O.D. Size	List
271TT0001	#0 - 1/4"	\$8.40
271TT0002	#10 - 1/2"	\$9.00



Wrenches will accommodate all HSS & Carbon Hand Taps within O.D. size.
O.D. Size = Actual Tap Size (machine screw thread).



Tap Reamer Wrench

Part #	O.D. Size	Size	List
270TW0000	#0-1/4"	TW0	\$10.09
270TW0004	#0-3/8"	TW4	\$14.16
270TW0005	#7-1/2"	TW5	\$16.99
270TW0006	#7-3/4"	TW6	\$21.71
270TW0007	1/4" → 1-1/8"	TW7	\$36.43



Single (1) Flute Counter Sinks - HSS

- ◆ HSS
- ◆ Milled Body
- ◆ Ground Flute

- Iron
- Steel
- Plastic
- Light to Medium Metals

60° Part #	82° Part #	90° Part #	100° Part #	Size	Shank Diameter	Shank Length	O/A	List
CI-60-1264	CI-82-1264	CI-90-1264	CI-100-1264	3/16"	3/16"	3/4"	1-1/2"	\$8.55
CI-60-1664	CI-82-1664	CI-90-1664	CI-100-1664	1/4"	1/4"	3/4"	2"	\$9.06
CI-60-2064	CI-82-2064	CI-90-2064	CI-100-2064	5/16"	1/4"	1"	2"	\$9.73
CI-60-2464	CI-82-2464	CI-90-2464	CI-100-2464	3/8"	1/4"	1"	2"	\$10.33
CI-60-3264	CI-82-3264	CI-90-3264	CI-100-3264	1/2"	1/4"	1"	2"	\$13.30
CI-60-4064	CI-82-4064	CI-90-4064	CI-100-4064	5/8"	3/8"	1-1/8"	2-3/4"	\$18.27
CI-60-4864	CI-82-4864	CI-90-4864	CI-100-4864	3/4"	3/8"	1-5/16"	2-3/4"	\$24.44
CI-60-5064	CI-82-5064	CI-90-5064	CI-100-5064	7/8"	1/2"	1-5/16"	2-3/4"	\$33.12
CI-60-6464	CI-82-6464	CI-90-6464	CI-100-6464	1"	1/2"	1-5/16"	2-3/4"	\$41.88



Three (3) Flute Counter Sinks - HSS

60° Part #	82° Part #	90° Part #	100° Part #	Size	Shank Diameter	Shank Length	O/A	List
R3-60-1664	R3-82-1664	R3-90-1664	R3-100-1664	1/4"	3/16"	3/4"	1-1/2"	\$7.65
R3-60-2464	R3-82-2464	R3-90-2464	R3-100-2464	3/8"	1/4"	7/8"	2-3/4"	\$9.21
R3-60-3264	R3-82-3264	R3-90-3264	R3-100-3264	1/2"	3/8"	1"	2"	\$12.62
R3-60-4064	R3-82-4064	R3-90-4064	R3-100-4064	5/8"	3/8"	1"	2-1/4"	\$17.16
R3-60-4864	R3-82-4864	R3-90-4864	R3-100-4864	3/4"	1/2"	1-1/4"	2-5/8"	\$21.38
R3-60-6464	R3-82-6464	R3-90-6464	R3-100-6464	1"	1/2"	1-1/4"	2-3/4"	\$33.86



CARDED

Part # SE-006-16
6 Pc. Screw Extractor Set
 #1, #2, #3, #4, #5, #6
Price Each \$14.95



Screw Extractor - LEFT HAND SPIRAL FLUTE

Part #	Size	Shank Diameter	Removes Screw or Pipe	List
SE0001	1	5/64"	3/32" to 5/32"	\$1.45
SE0002	2	7/64"	5/32" to 7/32"	\$1.54
SE0003	3	5/32"	7/32" to 9/32"	\$2.20
SE0004	4	1/4"	9/32" to 3/8", 1/8" Pipe	\$2.24
SE0005	5	19/64"	3/8" to 5/8", 1/4" Pipe	\$2.89
SE0006	6	13/32"	5/8" to 7/8", 3/8" Pipe	\$7.23
SE0007	7	17/32"	7/8" to 1-1/8", 1/2" Pipe	\$11.07
SE0008	8	13/16"	1-1/8" to 1-3/8", 3/4" Pipe	\$22.79
SE0009	9	1-1/16"	1-3/8" to 2", 1" Pipe	\$33.19

MAIN OFFICE
 INTERNATIONAL TOOL MANUFACTURING
 71-08 51ST. AVENUE, WOODSIDE, NY 11377
 (718) 446-0711 - (800) 247-5696 - FAX (718) 899-6553



INTERNATIONAL TOOL MANUFACTURING
 675-E-PROGRESS CENTER AVE., LAWRENCEVILLE, GA 30043
 (770) 962-5454 - (800) 229-1776 - FAX (770) 962-5869



Cylinder

Part #	Dia.	Cut	Qty.	List
CBA-1	1/4"	5/8"	1	\$17.12
CBA-3	3/8"	3/4"	1	\$24.07
CBA-5	1/2"	1"	1	\$37.76
CBA-7	3/4"	1"	1	\$81.55



Cylinder w/ End Cut

Part #	Dia.	Cut	Qty.	List
CBB-1	1/4"	5/8"	1	\$23.18
CBB-3	3/8"	3/4"	1	\$33.27
CBB-5	1/2"	1"	1	\$51.75
CBB-7	3/4"	1"	1	\$92.53



Cylinder w/ Radius

Part #	Dia.	Cut	Qty.	List
CBC-1	1/4"	5/8"	1	\$24.46
CBC-3	3/8"	3/4"	1	\$32.38
CBC-5	1/2"	1"	1	\$50.84
CBC-6	5/8"	1"	1	\$56.73



Ball

Part #	Dia.	Cut	Qty.	List
CBD-1	1/4"	1/4"	1	\$22.21
CBD-3	3/8"	3/8"	1	\$25.97
CBD-5	1/2"	1/2"	1	\$35.17



Oval

Part #	Dia.	Cut	Qty.	List
CBE-1	1/4"	3/8"	1	\$26.83
CBE-3	3/8"	5/8"	1	\$29.27
CBE-5	1/2"	7/8"	1	\$51.75
CBE-6	5/8"	1"	1	\$67.47



Tree w/ Radius

Part #	Dia.	Cut	Qty.	List
CBF-1	1/4"	5/8"	1	\$25.98
CBF-3	3/8"	3/4"	1	\$32.78
CBF-5	1/2"	1"	1	\$47.20
CBF-6	5/8"	1"	1	\$67.09



Tree w/ Point

Part #	Dia.	Cut	Qty.	List
CBG-1	1/4"	5/8"	1	\$25.96
CBG-3	3/8"	3/4"	1	\$33.32
CBG-5	1/2"	1"	1	\$47.20



Flame

Part #	Dia.	Cut	Qty.	List
CBH-1	1/4"	1/2"	1	\$29.21
CBH-5	1/2"	1-1/4"	1	\$65.06



Cone 60°

Part #	Dia.	Cut	Qty.	List
CBJ-1	1/4"	3/16"	1	\$24.07
CBJ-3	3/8"	1/4"	1	\$29.61
CBJ-5	1/2"	7/16"	1	\$36.54



Cone 90°

Part #	Dia.	Cut	Qty.	List
CBK-1	1/4"	1/4"	1	\$24.64
CBK-3	3/8"	3/8"	1	\$30.36
CBK-5	1/2"	1/2"	1	\$36.54



14° Taper w/ Radius

Part #	Dia.	Cut	Qty.	List
CBL-1	1/4"	5/8"	1	\$26.65
CBL-3	3/8"	1-1/16"	1	\$40.25
CBL-4	1/2"	1-1/8"	1	\$51.35
CBL-5	5/8"	1-3/16"	1	\$90.16
CBL-7	3/4"	1-1/2"	1	\$129.42



Pointed Cone

Part #	Dia.	Cut	Qty.	List
CBM-2	1/4"	3/4"	1	\$27.76
CBM-4	3/8"	5/8"	1	\$39.72
CBM-5	1/2"	7/8"	1	\$50.84



Inverted Cone

Part #	Dia.	Cut	Qty.	List
CBN-1	1/4"	5/16"	1	\$23.76
CBN-2	3/8"	3/8"	1	\$44.21
CBN-4	1/2"	1/2"	1	\$45.28

- ◆ Solid Carbide
- ◆ Double Cut
- ◆ Bright Finish

- Brass
- Bronze
- Copper
- Cast Iron
- Steel 40-55 Rc
- Steel 55-60 Rc
- Nickel
- Stainless Steel
- Weldments





1/8"
 5/32"
 3/16"
 7/32"
 1/4"
 9/32"
 5/16"
 11/32"
 3/8"
 13/32"
 7/16"
 15/32"
 1/2"

274MC0001
 13 Steps 1/8" - 1/2"
 List \$44.00



3/16"
 1/4"
 5/16"
 3/8"
 7/16"
 1/2"

274MC0002
 6 Steps 3/16" - 1/2"
 List \$42.85



1/4"
 5/16"
 3/8"
 7/16"
 1/2"
 9/16"
 5/8"
 11/16"
 3/4"

274MC0003
 9 Steps 1/4" - 3/4"
 List \$53.27

- ◆ HSS Step Drills
- ◆ Lobbed
- ◆ Non-Slip Shank
- ◆ Drill 1/8" Thick
- ◆ Double Flute
- ◆ Bright Finish

- Ferrous & Non-Ferrous Sheet Metals
- Plastic Laminates
- Sink Grade Stainless Steel
- Auto Body Repair
- Electrical
- HVAC



3/16"
 1/4"
 5/16"
 3/8"
 7/16"
 1/2"
 9/16"
 5/8"
 11/16"
 3/4"
 13/16"
 7/8"

274MC0004
 12 Steps 3/16" - 7/8"
 List \$59.58



7/16"
 1/2"
 9/16"
 5/8"
 11/16"
 3/4"
 13/16"
 7/8"
 15/16"
 1"
 1-1/16"
 1-1/8"

274MC0005
 12 Steps 7/16" - 1-1/8"
 List \$84.83



3/4"
 13/16"
 7/8"
 15/16"
 1"
 1-1/16"
 1-1/8"
 1-3/16"
 1-1/4"
 1-5/16"
 1-3/8"

274MC0006
 11 Steps 3/4" - 1-3/8"
 List \$113.09



3/8"
 7/16"
 3/4"
 For drilling 3 standard size holes to accommodate drive screws for knockout punches.

274MC0007
 3 Steps 3/8" - 3/4"
 List \$69.42



7/8"
 1-1/8"
 7/8" hole for 1/2" conduit.
 1-1/8" hole for 3/4" conduit.

274MC0008
 2 Steps 7/8" - 1-1/8"
 List \$82.81



7/8"
 1-1/8"
 1-7/32"
 1-1/4"
 1-3/8"
 1-7/32" hole for oil tight switches.

274MC0009
 5 Steps 7/8" - 1-3/8"
 List \$99.50

Recommended Cutting Speeds:	
1/8" - 3/8"1200RPM
3/8" - 1/2"600 RPM
1/2" - 5/8"400 RPM
5/8" - 3/4"350 RPM
3/4" - 7/8"300 RPM
1"260 RPM
1-1/8"240 RPM
1-1/2"200 RPM

More accurate control of hole size in various sheet materials up to 1/8" thick. Each step bit drills a range of sizes. The further the bit advances, the larger the diameter of the hole gets. Because step drill bits enter the material one step at a time, the operator can drill the desired hole by counting the individual steps, or by using a washer as a simple stop. The self starting tip eliminates the need for pilot holes. Applications include junction boxes, switch boxes, metal studs, electrical applications, lighting fixtures, auto body work, and many other uses.



7/8"

274MC0010
 1 Cone 7/8"
 List \$59.58



BARCODED

SOLD INDIVIDUALLY



3-FLAT SHANK



Reamer - CAR / Construction - Standard - HSS

Part #	Size	Point Diameter	OAL	Flute	Shank	Type	List
CRF-2464	3/8"	0.250	5"	4"	3/8"	3-Flat Car / Constr.	\$40.64
CRF-2864	7/16"	0.281	5-1/4"	4"	7/16"	3-Flat Car / Constr.	\$45.96
CRF-3264	1/2"	0.343	6"	4-1/2"	1/2"	3-Flat Car / Constr.	\$52.16
CRF-3664	9/16"	0.343	6-1/4"	4-1/2"	1/2"	3-Flat Car / Constr.	\$60.74
CRF-4064	5/8"	0.343	6-1/2"	4-1/2"	1/2"	3-Flat Car / Constr.	\$67.02
CRF-4464	11/16"	0.375	7"	4-1/2"	1/2"	3-Flat Car / Constr.	\$77.53
CRF-4864	3/4"	0.406	7-1/4"	5"	1/2"	3-Flat Car / Constr.	\$89.42
CRF-5264	13/16"	0.468	7-1/4"	5"	1/2"	3-Flat Car / Constr.	\$94.81
CRF-5664	7/8"	0.500	7-1/4"	5"	1/2"	3-Flat Car / Constr.	\$106.29
CRF-6064	15/16"	0.585	7-1/4"	5"	1/2"	3-Flat Car / Constr.	\$118.74
CRF-6464	1"	0.594	7-1/4"	5"	1/2"	3-Flat Car / Constr.	\$125.87
CRF-6864	1-1/16"	0.807	7-1/4"	5"	1/2"	3-Flat Car / Constr.	\$145.73

- ◆ High Speed Steel (HSS)
- ◆ Tapered Point
- ◆ Left-Hand Spiral
- ◆ Right-Hand Cut
- ◆ 3-Flat Shanks

Made in Europe

Reaming Steel For Aligning Existing Holes & Bolt / Rivet Installation



BARCODED

Reamer - CAR - Standard - HEX - HSS

Part #	Size	Point Diameter	OAL	Flute	Shank	Type	List
CHX-4464	11/16"	0.375	6-3/8"	4-1/2"	1-1/16"	HEX Car	\$76.37
CHX-5264	13/16"	0.468	7"	5"	1-1/4"	HEX Car	\$90.50
CHX-6064	15/16"	0.585	7"	5"	1-7/16"	HEX Car	\$107.58
CHX-6864	1-1/16"	0.807	7"	5"	1-5/8"	HEX Car	\$139.68



- ◆ High Speed Steel (HSS)
- ◆ Tapered Point
- ◆ Left-Hand Spiral
- ◆ Right-Hand Cut
- ◆ HEX Nut Shank

Made in Europe



3-FLAT SHANK

Made In



Black & Gold

- ◆ High Speed Steel (HSS)
- ◆ Tapered Point
- ◆ Left-Hand Spiral
- ◆ Right-Hand Cut
- ◆ 3-Flat Shanks
- Structural Plate

Reamer - CAR / Construction - Standard - HSS

Part #	Size	Point Diameter	OAL	Flute	Shank	Type	List
ASF-2464	3/8"	0.250	5"	4"	3/8"	3-Flat Car / Constr.	\$69.87
ASF-3264	1/2"	0.281	6"	4-1/2"	1/2"	3-Flat Car / Constr.	\$83.23
ASF-3664	9/16"	0.343	6-1/4"	4-1/2"	1/2"	3-Flat Car / Constr.	\$88.58
ASF-4064	5/8"	0.343	6-1/2"	4-1/2"	1/2"	3-Flat Car / Constr.	\$96.66
ASF-4464	11/16"	0.375	7"	4-1/2"	1/2"	3-Flat Car / Constr.	\$107.43
ASF-4864	3/4"	0.406	7-1/4"	5"	1/2"	3-Flat Car / Constr.	\$128.90
ASF-5264	13/16"	0.468	7-1/4"	5"	1/2"	3-Flat Car / Constr.	\$132.11
ASF-5664	7/8"	0.500	7-1/4"	5"	1/2"	3-Flat Car / Constr.	\$145.62
ASF-6064	15/16"	0.585	7-1/4"	5"	1/2"	3-Flat Car / Constr.	\$145.62
ASF-6464	1"	0.594	7-1/4"	5"	1/2"	3-Flat Car / Constr.	\$170.82
ASF-8064	1-1/4"	0.719	7-1/4"	5"	1/2"	3-Flat Car / Constr.	\$266.89

Reaming Steel For Aligning Existing Holes & Bolt / Rivet Installation



BARCODED



3-FLAT SHANK

Made In



Black & Gold

- ◆ High Speed Steel (HSS)
- ◆ Tapered Point
- ◆ Left-Hand Spiral
- ◆ Right-Hand Cut
- ◆ 3-Flat Shanks
- Structural Plate

Reamer - CAR / Construction - *Fast Spiral* - HSS

Part #	Size	Point Diameter	OAL	Flute	Shank	Type	List
AFC-2464	3/8"	0.250	5"	4"	3/8"	3-Flat Car / Constr.	\$77.07
AFC-3264	1/2"	0.281	6"	4-1/2"	1/2"	3-Flat Car / Constr.	\$91.75
AFC-3664	9/16"	0.343	6-1/4"	4-1/2"	1/2"	3-Flat Car / Constr.	\$97.43
AFC-4064	5/8"	0.343	6-1/2"	4-1/2"	1/2"	3-Flat Car / Constr.	\$106.76
AFC-4464	11/16"	0.375	7"	4-1/2"	1/2"	3-Flat Car / Constr.	\$118.78
AFC-4864	3/4"	0.406	7-1/4"	5"	1/2"	3-Flat Car / Constr.	\$141.86
AFC-5264	13/16"	0.468	7-1/4"	5"	1/2"	3-Flat Car / Constr.	\$145.45
AFC-5664	7/8"	0.500	7-1/4"	5"	1/2"	3-Flat Car / Constr.	\$160.81
AFC-6064	15/16"	0.585	7-1/4"	5"	1/2"	3-Flat Car / Constr.	\$160.81
AFC-6464	1"	0.594	7-1/4"	5"	1/2"	3-Flat Car / Constr.	\$188.17
AFC-8064	1-1/4"	0.719	7-1/4"	5"	1/2"	3-Flat Car / Constr.	\$293.59



Made In



Black & Gold

- ◆ High Speed Steel (HSS)
- ◆ Tapered Point
- ◆ Left-Hand Spiral
- ◆ Right-Hand Cut
- ◆ HEX Shanks
- Structural Plate

Reamer - CAR - Spiral Flute - HEX - HSS

Part #	Size	Point Diameter	OAL	Flute	Shank	Type	List
ACX-4464	11/16"	0.375	6-3/8"	4-1/2"	1-1/16"	HEX Car	\$126.12
ACX-5264	13/16"	0.468	7"	5"	1-1/4"	HEX Car	\$151.14
ACX-6064	15/16"	0.585	7"	5"	1-7/16"	HEX Car	\$171.02
ACX-6864	1-1/16"	0.807	7"	5"	1-5/8"	HEX Car	\$223.93



Reamer - BRIDGE - Spiral Flute - HEX - HSS

Part #	Size	Point Diameter	OAL	Flute	Shank	Type	List
ABX-4464	11/16"	0.375	9-1/4"	7-1/8"	1-1/16"	HEX Bridge	\$154.06
ABX-5264	13/16"	0.468	9-3/8"	7-3/8"	1-1/4"	HEX Bridge	\$175.28
ABX-6064	15/16"	0.585	9-3/8"	7-3/8"	1-7/16"	HEX Bridge	\$199.20
ABX-6864	1-1/16"	0.807	9-3/8"	7-3/8"	1-5/8"	HEX Bridge	\$246.25



Reamer - BRIDGE - Straight Flute - Morse Taper - HSS

Part #	Size	Point Diameter	OAL	Flute	Shank	Type	List
ABT-4464	11/16"	0.375	11-3/4"	7-1/8"	#3	Taper Bridge - Straight	\$128.55
ABT-5264	13/16"	0.468	12"	7-3/8"	#3	Taper Bridge - Straight	\$147.52
ABT-6064	15/16"	0.585	12"	7-3/8"	#3	Taper Bridge - Straight	\$167.73
ABT-6864	1-1/16"	0.807	12"	7-3/8"	#3	Taper Bridge - Straight	\$207.29

Made In



Black & Gold

- ◆ High Speed Steel (HSS)
- ◆ Tapered Point
- ◆ Left-Hand Spiral
- ◆ Right-Hand Cut
- ◆ Taper Shanks
- Structural Steel Assemblies
- Bridge Erection
- Ship Construction

Reamer - BRIDGE - Spiral Flute - Morse Taper - HSS

Part #	Size	Point Diameter	OAL	Flute	Shank	Type	List
AFF-4464	11/16"	0.375	11-3/4"	7-1/8"	#3	Taper Bridge - Spiral	\$128.55
AFF-5264	13/16"	0.468	12"	7-3/8"	#3	Taper Bridge - Spiral	\$127.96
AFF-6064	15/16"	0.585	12"	7-3/8"	#3	Taper Bridge - Spiral	\$157.37
AFF-6864	1-1/16"	0.807	12"	7-3/8"	#3	Taper Bridge - Spiral	\$212.23

MAIN OFFICE
 INTERNATIONAL TOOL MANUFACTURING
 71-08 51ST. AVENUE, WOODSIDE, NY 11377
 (718) 446-0711 - (800) 247-5696 - FAX (718) 899-6553



INTERNATIONAL TOOL MANUFACTURING
 675-E-PROGRESS CENTER AVE., LAWRENCEVILLE, GA 30043
 (770) 962-5454 - (800) 229-1776 - FAX (770) 962-5869



1" HSS Annular Cutter

Part #	Size	x	OAL	List
100MC2864	7/16"	X	1"	\$48.29
100MC3264	1/2"	X	1"	\$48.29
100MC3664	9/16"	X	1"	\$50.49
100MC4064	5/8"	X	1"	\$52.66
100MC4464	11/16"	X	1"	\$56.87
100MC4864	3/4"	X	1"	\$59.28
100MC5264	13/16"	X	1"	\$63.67
100MC5664	7/8"	X	1"	\$72.38
100MC6064	15/16"	X	1"	\$74.68
100MC6464	1"	X	1"	\$81.27
100MC6864	1-1/16"	X	1"	\$83.45
100MC7264	1-1/8"	X	1"	\$92.24
100MC7664	1-3/16"	X	1"	\$95.62
100MC8064	1-1/4"	X	1"	\$105.43
100MC8464	1-5/16"	X	1"	\$127.43
100MC8864	1-3/8"	X	1"	\$136.20
100MC9264	1-7/16"	X	1"	\$162.58
100MC9664	1-1/2"	X	1"	\$166.99
100MC1916	1-9/16"	X	1"	\$171.36
100MC1058	1-5/8"	X	1"	\$180.18
100MC1116	1-11/16"	X	1"	\$188.96
100MC1034	1-3/4"	X	1"	\$202.10
100MC1316	1-13/16"	X	1"	\$210.93
100MC1078	1-7/8"	X	1"	\$219.75
100MC1516	1-15/16"	X	1"	\$219.75
100MC2002	2"	X	1"	\$237.30
100MC2116	2-1/16"	X	1"	\$246.12

2" HSS Annular Cutter

Part #	Size	x	OAL	List
200MC2864	7/16"	X	2"	\$61.49
200MC3264	1/2"	X	2"	\$61.49
200MC3664	9/16"	X	2"	\$65.60
200MC4064	5/8"	X	2"	\$74.68
200MC4464	11/16"	X	2"	\$83.45
200MC4864	3/4"	X	2"	\$87.86
200MC5264	13/16"	X	2"	\$96.64
200MC5664	7/8"	X	2"	\$105.34
200MC6064	15/16"	X	2"	\$105.34
200MC6464	1"	X	2"	\$118.60
200MC6864	1-1/16"	X	2"	\$123.02
200MC7264	1-1/8"	X	2"	\$131.80
200MC7664	1-3/16"	X	2"	\$135.18
200MC8064	1-1/4"	X	2"	\$144.99
200MC8464	1-5/16"	X	2"	\$162.58
200MC8864	1-3/8"	X	2"	\$171.36
200MC9264	1-7/16"	X	2"	\$188.96
200MC9664	1-1/2"	X	2"	\$197.74
200MC1916	1-9/16"	X	2"	\$224.12
200MC1058	1-5/8"	X	2"	\$224.12
200MC1116	1-11/16"	X	2"	\$241.71
200MC1034	1-3/4"	X	2"	\$250.50
200MC1316	1-13/16"	X	2"	\$259.32
200MC1078	1-7/8"	X	2"	\$286.35
200MC1516	1-15/16"	X	2"	\$286.35
200MC2002	2"	X	2"	\$320.70
200MC2116	2-1/16"	X	2"	\$332.17



ENGLAND

- ◆ M2 HSS
- ◆ 3/4" Weldon Shanks
- ◆ Aggressive Cutting Edges
- ◆ No Center Punch Required
- ◆ Cut up to 2"
- ◆ For All Magnetic Drills



BARCODED



Allows overlap cut on existing holes

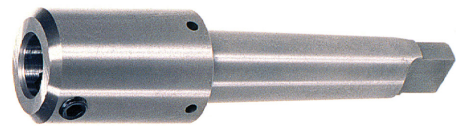

Pilot Pins

Part #	Description	List
PJ00011	Pilot 1" Cutter	\$10.03
PJ00021	Pilot 2" Cutter	\$12.10
PJ00716	Pilot 7/16" x 1" Cutter ONLY	\$10.03
PJ02716	Pilot 7/16" x 2" Cutter ONLY	\$12.10

Arbor Adapters

Part #	Description	List
AD0002	Morse #2	\$370.30
AD0003	Morse #3	\$380.00

Converts Morse Tapers to 3/4" Arbor for All **ITM** and Conventional Annular Cutters.

MAIN OFFICE
 INTERNATIONAL TOOL MANUFACTURING
 71-08 51ST. AVENUE, WOODSIDE, NY 11377
 (718) 446-0711 - (800) 247-5696 - FAX (718) 899-6553



INTERNATIONAL TOOL MANUFACTURING
 675-E-PROGRESS CENTER AVE., LAWRENCEVILLE, GA 30043
 (770) 962-5454 - (800) 229-1776 - FAX (770) 962-5869



- **Cut Faster**
- **Cut Cleaner**
- **Lasts Longer**



- ◆ Tungsten Carbide Teeth
- ◆ 3/4" Weldon Shanks
- ◆ Aggressive Cutting Edges
- ◆ No Center Punch Required
- ◆ For All Magnetic Drills

1" TCT Annular Cutter

Part #	Size	x	OAL	List
ATAC-3264	1/2"	X	1-3/8"	\$88.77
ATAC-3664	9/16"	X	1-3/8"	\$90.66
ATAC-4064	5/8"	X	1-3/8"	\$91.54
ATAC-4464	11/16"	X	1-3/8"	\$92.27
ATAC-4864	3/4"	X	1-3/8"	\$93.32
ATAC-5264	13/16"	X	1-3/8"	\$94.67
ATAC-5664	7/8"	X	1-3/8"	\$97.89
ATAC-6064	15/16"	X	1-3/8"	\$99.03
ATAC-6464	1"	X	1-3/8"	\$101.99
ATAC-6864	1-1/16"	X	1-3/8"	\$109.55
ATAC-7264	1-1/8"	X	1-3/8"	\$111.35
ATAC-8864	1-3/8"	X	1-3/8"	\$131.43
ATAC-9264	1-7/16"	X	1-3/8"	\$150.74
ATAC-9664	1-1/2"	X	1-3/8"	\$153.61

2" TCT Annular Cutter

Part #	Size	x	OAL	List
BTAC-3264	1/2"	X	2"	\$100.18
BTAC-3664	9/16"	X	2"	\$100.75
BTAC-4064	5/8"	X	2"	\$101.09
BTAC-4464	11/16"	X	2"	\$103.36
BTAC-4864	3/4"	X	2"	\$105.01
BTAC-5264	13/16"	X	2"	\$106.04
BTAC-5664	7/8"	X	2"	\$107.70
BTAC-6064	15/16"	X	2"	\$109.61
BTAC-6464	1"	X	2"	\$111.35
BTAC-6864	1-1/16"	X	2"	\$122.71
BTAC-7264	1-1/8"	X	2"	\$123.71
BTAC-8864	1-3/8"	X	2"	\$146.38
BTAC-9264	1-7/16"	X	2"	\$166.46
BTAC-9664	1-1/2"	X	2"	\$172.50
BTAC-2002	2"	X	2"	\$236.61

3" TCT Annular Cutter

Part #	Size	x	OAL	List
CTAC-3264	1/2"	X	3"	\$147.34
CTAC-3664	9/16"	X	3"	\$150.00
CTAC-4064	5/8"	X	3"	\$157.98
CTAC-4464	11/16"	X	3"	\$161.43
CTAC-4864	3/4"	X	3"	\$166.82
CTAC-5264	13/16"	X	3"	\$168.76
CTAC-5664	7/8"	X	3"	\$171.41
CTAC-6064	15/16"	X	3"	\$173.64
CTAC-6464	1"	X	3"	\$177.06
CTAC-6864	1-1/16"	X	3"	\$193.43
CTAC-7264	1-1/8"	X	3"	\$196.13
CTAC-8864	1-3/8"	X	3"	\$217.38
CTAC-9664	1-1/2"	X	3"	\$264.14
CTAC-2002	2"	X	3"	\$353.88

4" TCT Annular Cutter

Part #	Size	x	OAL	List
RTAC-4864	3/4"	X	4"	\$202.21
RTAC-5264	13/16"	X	4"	\$202.21
RTAC-5664	7/8"	X	4"	\$202.21
RTAC-6064	15/16"	X	4"	\$202.21
RTAC-6464	1"	X	4"	\$202.21
RTAC-6864	1-1/16"	X	4"	\$231.32
RTAC-7264	1-1/8"	X	4"	\$231.32
RTAC-8864	1-3/8"	X	4"	\$264.14
RTAC-9664	1-1/2"	X	4"	\$327.36
RTAC-1058	1-5/8"	X	4"	\$370.33
RTAC-1034	1-3/4"	X	4"	\$370.33
RTAC-2002	2"	X	4"	\$436.05

- Stainless Steel
- Castings



BARCODED



Allows overlap cut on existing holes



Pilot Pins

Part #	DEEP	CUTTER	List
PT-10	1-3/8"	1/2" - 5/8"	\$12.59
PT-12	1-3/8"	11/16" - 1-1/2"	\$11.49
PT-20	2"	1/2" - 5/8"	\$12.59
PT-22	2"	11/16" - 2-3/8"	\$13.40
PT-25	2"	2-1/2" - 4"	\$20.67
PT-30	3"	9/16" - 11/16"	\$18.39
PT-32	3"	3/4" - 2-3/8"	\$20.67
PT-35	3"	2-1/2" - 4"	\$25.72
PT-40	4"	3/4" - 2"	\$25.72

Similar to Annular Cutters, designed with Tungsten Carbide Teeth (TCT) for much faster deep drilling.

- **Cut Faster**
- **Cut Cleaner**
- **Lasts Longer**



T.C.T. Cutter - 3/16" DEEP CUT

Part #	Size	Cut	Shank	List
HF0012	5/8"	3/16"	3/8"	\$31.50
HF0013	11/16"	3/16"	3/8"	\$31.50
HF0014	3/4"	3/16"	3/8"	\$35.02
HF0015	13/16"	3/16"	3/8"	\$35.02
HF0016	7/8"	3/16"	3/8"	\$35.02
HF0017	15/16"	3/16"	3/8"	\$35.02
HF0018	1"	3/16"	3/8"	\$35.02
HF0119	1-1/16"	3/16"	3/8"	\$38.89
HF0019	1-1/8"	3/16"	3/8"	\$38.89
HF0021	1-1/4"	3/16"	3/8"	\$45.00
HF0023	1-3/8"	3/16"	3/8"	\$45.00
HF0024	1-1/2"	3/16"	3/8"	\$52.22
HF0025	1-5/8"	3/16"	3/8"	\$61.25
HF0026	1-3/4"	3/16"	3/8"	\$61.25
HF0027	1-7/8"	3/16"	3/8"	\$62.00
HF0028	2"	3/16"	3/8"	\$69.50
HF0029	2-1/8"	3/16"	3/8"	\$69.50
HF0030	2-1/4"	3/16"	3/8"	\$87.78
HF0032	2-3/8"	3/16"	3/8"	\$87.78
HF0033	2-1/2"	3/16"	1/2"	\$103.89
HF0135	2-3/4"	3/16"	1/2"	\$111.67
HF0035	3"	3/16"	1/2"	\$123.50
HF0138	3-1/4"	3/16"	1/2"	\$138.81
HF0036	3-1/2"	3/16"	1/2"	\$148.83
HF0140	3-5/8"	3/16"	1/2"	\$168.13
HF0037	4"	3/16"	1/2"	\$175.00

T.C.T. Cutter - 7/8" DEEP CUT

Part #	Size	Cut	Shank	List
HG0011	9/16"	7/8"	3/8"	\$41.67
HG0012	5/8"	7/8"	3/8"	\$41.67
HG0013	11/16"	7/8"	3/8"	\$41.67
HG0014	3/4"	7/8"	3/8"	\$46.75
HG0015	13/16"	7/8"	3/8"	\$46.75
HG0016	7/8"	7/8"	3/8"	\$46.75
HG0017	15/16"	7/8"	3/8"	\$46.75
HG0018	1"	7/8"	3/8"	\$46.75
HG0119	1-1/16"	7/8"	3/8"	\$54.17
HG0019	1-1/8"	7/8"	3/8"	\$54.17
HG0021	1-1/4"	7/8"	3/8"	\$63.19
HG0023	1-3/8"	7/8"	3/8"	\$63.19
HG0024	1-1/2"	7/8"	3/8"	\$72.92
HG0025	1-5/8"	7/8"	3/8"	\$84.72
HG0026	1-3/4"	7/8"	3/8"	\$84.72
HG0027	1-7/8"	7/8"	3/8"	\$84.94
HG0028	2"	7/8"	3/8"	\$94.72
HG0029	2-1/8"	7/8"	3/8"	\$94.72
HG0030	2-1/4"	7/8"	3/8"	\$108.17
HG0032	2-3/8"	7/8"	3/8"	\$108.17
HG0033	2-1/2"	7/8"	1/2"	\$127.11
HG0135	2-3/4"	7/8"	1/2"	\$137.50
HG0035	3"	7/8"	1/2"	\$159.50
HG0138	3-1/4"	7/8"	1/2"	\$162.78
HG0036	3-1/2"	7/8"	1/2"	\$174.44
HG0037	4"	7/8"	1/2"	\$215.11
HG0050	5"	7/8"	1/2"	\$265.25

- ◆ Made In Taiwan.
- ◆ Excellent Wear and Heat resistance.
- ◆ Tungsten Carbide Teeth
- ◆ Cuts Stainless Steel and Tough Alloys.
- ◆ Ejects the Slug Saving Time.
- ◆ Works in 3/8" & 1/2" Chucks

- Stainless Steel
- Aluminum
- Copper
- Iron
- Cast Iron

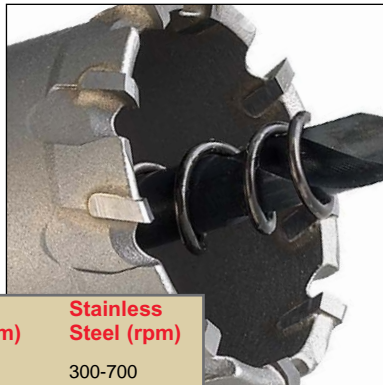

Replacement Parts

Part #	Description	List
HF-PILOT	CENTER DRILL φ6mm x 50L	\$8.25
HF-S	SPRING 1.2MM X 16L	\$0.75
HG-PILOT	CENTER DRILL φ6mm x 60L	\$9.45
HG-S	SPRING 1.2MM X 23L	\$0.75

Size	Steel (rpm)	Stainless Steel (rpm)
9/16" to 13/16"	700-1000	300-700
7/8" to 1-3/16"	500-800	200-450
1-1/4" to 1-9/16"	300-600	175-315
1-5/8" to 2"	200-500	120-225
2-1/16" to 2-3/8"	200-400	95-195
2-7/16" to 3"	150-300	80-150
3-1/16" to 5"	100-200	60-120

Valid for 3/16" & 1" Deep T.C.T. Carbide Tipped Hole Saws.

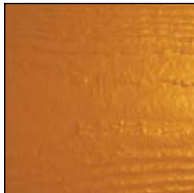

Made In



Composite Cutter

Part #	Size	OAL	Shank	List
CHS-16	1"	6"	1/2"	\$135.96
CHS-18	1-1/8"	6"	1/2"	\$139.25
CHS-20	1-1/4"	6"	1/2"	\$140.88
CHS-22	1-3/8"	6"	1/2"	\$144.13
CHS-24	1-1/2"	6"	1/2"	\$150.67
CHS-26	1-5/8"	6"	1/2"	\$153.96
CHS-28	1-3/4"	6"	1/2"	\$158.83
CHS-32	2"	6"	1/2"	\$171.96
CHS-34	2-1/8"	6"	1/2"	\$178.46
CHS-36	2-1/4"	6"	1/2"	\$186.63
CHS-40	2-1/2"	6"	1/2"	\$194.79
CHS-48	3"	6"	1/2"	\$214.42
CHS-64	4"	6"	1/2"	\$258.50

- ◆ Carbide Teeth
- ◆ Carbide Pilot
- ◆ Ejector Spring
- ◆ 2" Drilling Depth
- ◆ 3-Flat Shank

- Hard Plastic
- Stucco
- Clay Pipe
- Hardy Board
- Dry Lath & Plaster
- Wood with Nails
- Aluminum Siding
- Hard or Composite Plastic

Also Available:

- Extension Shanks
- Replacement Pilots
- Replacement Springs

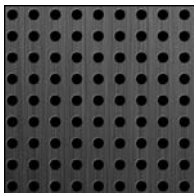

Made In



Interrupter

Part #	Size	OAL	Shank	List
IC-12	3/4"	6"	3/8"	\$131.96
IC-14	7/8"	6"	3/8"	\$133.58
IC-16	1"	6"	1/2"	\$139.54
IC-18	1-1/8"	6"	1/2"	\$147.71
IC-20	1-1/4"	6"	1/2"	\$154.21
IC-22	1-3/8"	6"	1/2"	\$157.50
IC-24	1-1/2"	6"	1/2"	\$162.38
IC-28	1-3/4"	6"	1/2"	\$167.29
IC-32	2"	6"	1/2"	\$188.54
IC-36	2-1/4"	6"	1/2"	\$195.08
IC-38	2-3/8"	6"	1/2"	\$201.63
IC-40	2-1/2"	6"	1/2"	\$208.17
IC-44	2-3/4"	6"	1/2"	\$224.50
IC-48	3"	6"	1/2"	\$244.08
IC-52	3-1/4"	6"	1/2"	\$268.58
IC-56	3-1/2"	6"	1/2"	\$284.92
IC-60	3-3/4"	6"	1/2"	\$301.25
IC-64	4"	6"	1/2"	\$302.88

- ◆ Carbide Teeth
- ◆ HSS Pilot
- ◆ Ejector Spring
- ◆ 2" Drilling Depth
- ◆ 3-Flat Shank

- Pipe
- Trench Duct
- Cellular Metal
- Ferrous Metals
- Non-Ferrous Metals

Also Available:

- Extension Shanks
- Replacement Pilots
- Replacement Springs



HSS Bell Hanger - Feeler Bits With Fish Hole (Electrical / Wire)

Part #	Size	OAL	Shank	Qty.	List	Part #	Size	OAL	Shank	Qty.	List
308BH1200	3/16"	12"	3/16"	1	\$10.80	308BH2403	3/8"	24"	3/8"	1	\$19.24
308BH1800	3/16"	18"	3/16"	1	\$11.50	308BH3003	3/8"	30"	3/8"	1	\$21.32
308BH1201	1/4"	12"	1/4"	1	\$11.34	308BH4203	3/8"	42"	3/8"	1	\$44.19
308BH1801	1/4"	18"	1/4"	1	\$12.50	308BH4803	3/8"	48"	3/8"	1	\$54.36
308BH2401	1/4"	24"	1/4"	1	\$15.60	308BH1806	7/16"	18"	3/8"	1	\$25.50
308BH3001	1/4"	30"	1/4"	1	\$18.93	308BH1204	1/2"	12"	3/8"	1	\$15.22
308BH4201	1/4"	42"	1/4"	1	\$26.92	308BH1804	1/2"	18"	3/8"	1	\$17.76
308BH1202	5/16"	12"	5/16"	1	\$12.55	308BH2404	1/2"	24"	3/8"	1	\$25.12
308BH1802	5/16"	18"	5/16"	1	\$14.05	308BH3004	1/2"	30"	3/8"	1	\$26.90
308BH2402	5/16"	24"	5/16"	1	\$18.68	308BH4204	1/2"	42"	3/8"	1	\$53.40
308BH1203	3/8"	12"	3/8"	1	\$13.42	308BH4804	1/2"	48"	3/8"	1	\$61.31
308BH1803	3/8"	18"	3/8"	1	\$15.31	308BH1858	5/8"	18"	1/2"	1	\$22.85
						308BH1805	3/4"	18"	1/2"	1	\$24.90
						308BH1810	1"	18"	1/2"	1	\$31.25

- ◆ Fish Hole In Flute For Pulling Wire
- ◆ Special Point For Fast Drilling In Wood & Metal
- ◆ Tapering For Quick Chip Clearance
- Telephone Installation
- Burglar Alarms
- Wire & Cable Applications



CARBON STEEL Bell Hanger - Feeler Bits With Fish Hole

ALL BELL HANGER DRILL BITS ARE SOLD INDIVIDUALLY

Part #	Size	OAL	Shank	Qty.	List	Part #	Size	OAL	Shank	Qty.	List
308CS1412	1/4"	12"	1/4"	1	\$5.45	308CS3818	3/8"	18"	3/8"	1	\$7.88
308CS1418	1/4"	18"	1/4"	1	\$6.42	308CS3824	3/8"	24"	3/8"	1	\$11.32
308CS1424	1/4"	24"	1/4"	1	\$9.05						

Less expensive than High Speed Steel (HSS) - Carbon Steel drills all wood, studs, aluminum, insulation, and drywall. Will not perform as well as HSS in steel.



Carbide Tip Bell Hanger - Feeler Bits With Fish Hole (Electrical / Wire)

- ◆ Fish Hole In Flute For Pulling Wire
- ◆ Special Point For Fast Drilling In Masonry & Wood
- Telephone Installation
- Burglar Alarms
- Wire & Cable Applications

Part #	Size	OAL	Shank	Qty.	List	Part #	Size	OAL	Shank	Qty.	List
308CT1301	1/4"	13"	1/4"	1	\$11.94	308CT1304	1/2"	13"	3/8"	1	\$14.06
308CT1801	1/4"	18"	1/4"	1	\$13.01	308CT1804	1/2"	18"	3/8"	1	\$17.82
308CT2401	1/4"	24"	1/4"	1	\$15.31	308CT2404	1/2"	24"	3/8"	1	\$18.86
308CT1302	5/16"	13"	5/16"	1	\$12.87	308CT3004	1/2"	30"	3/8"	1	\$22.14
308CT1802	5/16"	18"	5/16"	1	\$14.31	308CT1305	3/4"	13"	1/2"	1	\$26.95
308CT2402	5/16"	24"	5/16"	1	\$15.31	308CT1805	3/4"	18"	1/2"	1	\$38.61
308CT1303	3/8"	13"	3/8"	1	\$13.33						
308CT1803	3/8"	18"	3/8"	1	\$15.01						
308CT2403	3/8"	24"	3/8"	1	\$16.19						
308CT3003	3/8"	30"	3/8"	1	\$18.45						

Electrician's Stretch Bits - Fish Bits

Part #	Size	X	OAL	Shank	Application	List
308FB1838	3/8"	X	18"	3/16"	Popular with alarm & communication installers for pulling light wire.	\$36.70
308FB2438	3/8"	X	24"	3/16"		\$38.63
308FB3638	3/8"	X	36"	3/16"		\$40.66
308FB5438	3/8"	X	54"	3/16"		\$45.18
308FB7238	3/8"	X	72"	3/16"		\$50.32
<hr/>						
308FB1812	1/2"	X	18"	3/16"	Popular with electricians and others for pulling heavier wire.	\$41.63
308FB2412	1/2"	X	24"	3/16"		\$43.82
308FB3612	1/2"	X	36"	3/16"		\$47.95
308FB5412	1/2"	X	54"	3/16"		\$48.69
308FB7212	1/2"	X	72"	3/16"		\$53.27
<hr/>						
308FB1896	9/16"	X	18"	3/16"	Popular with electricians and others for pulling heavier wire.	\$45.60
308FB2496	9/16"	X	24"	3/16"		\$48.00
308FB3696	9/16"	X	36"	3/16"		\$51.53
308FB5496	9/16"	X	54"	3/16"		\$53.33
308FB7296	9/16"	X	72"	3/16"		\$57.25
<hr/>						
308FB5434	3/4"	X	54"	3/16"	Popular with electricians and others for pulling heavier wire	\$61.95
308FB7234	3/4"	X	72"	3/16"		\$65.69

308FBG	Steering Guide				Helps manipulate bits while within the wall cavity.	\$37.10
--------	----------------	--	--	--	---	---------



- ◆ Self Drilling
- ◆ Fish Hole
- ◆ 3/16" Flexible Shaft
- Wood
- Studs
- Insulation

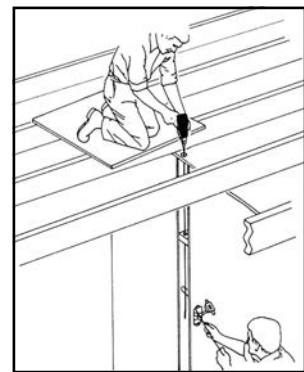

Stretch Bits are constructed of a high carbon steel self-feed auger bit, permanently brazed to a flexible shaft. This tool can be inserted through small wall openings enabling the operator to bore holes through studs within the wall cavities without damaging finished walls or ceilings.

Eye Holes are provided at each end of the Stretch Bits which allow easy retrieval of wires from either direction after drilling.



- ◆ M2 HSS
 - ◆ Straight Shank To 1/2", then Reduced
 - ◆ Sharp Cutting Edge to Drill In Many Different Materials
- Mild Steel
 - Aluminum
 - Cast Iron
 - Wood
- ⊙ Precision point angle for effective penetration through steel and wood.
 - ⊙ Extra length flute with continuous cutting edges for drilling deep holes and fast chip removal.
 - ⊙ Reduced shank fits all drill motors with 1/2" chucks.
 - ⊙ Non-slip grips prevent the bit from spinning in the chuck.

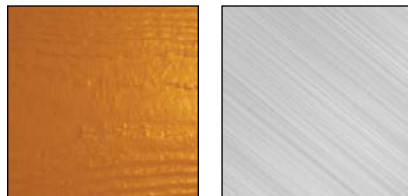

12" Long Boy - HSS

Part #	Size	Dec.	OAL	Flute	Qty.	List
216HS0864	1/8"	.1250	12"	9"	1	\$12.37
216HS1264	3/16"	.1875	12"	9"	1	\$12.37
216HS1464	7/32"	.2188	12"	9"	1	\$13.19
216HS1664	1/4"	.2500	12"	9"	1	\$14.04
216HS1864	9/32"	.2812	12"	9"	1	\$14.38
216HS2064	5/16"	.3125	12"	9"	1	\$20.13
216HS2464	3/8"	.3750	12"	9"	1	\$23.21
216HS2864	7/16"	.4375	12"	9"	1	\$46.46
216HS3264	1/2"	.5000	12"	9"	1	\$46.46
218HS3664	9/16"	.5625	12"	9"	1	\$65.29
218HS4064	5/8"	.6250	12"	9"	1	\$75.92
218HS4464	11/16"	.6875	12"	9"	1	\$87.58
218HS4864	3/4"	.7500	12"	9"	1	\$97.08
218HS5264	13/16"	.8125	12"	9"	1	\$104.38
218HS5664	7/8"	.8750	12"	9"	1	\$117.60
218HS6064	15/16"	.9375	12"	9"	1	\$131.52
218HS6464	1"	1.000	12"	9"	1	\$141.52
218HS7264	1-1/8"	1.1250	12"	9"	1	\$193.51

18" Long Boy - HSS

Part #	Size	Dec.	OAL	Flute	Qty.	List
217HS1664	1/4"	.2500	18"	14"	1	\$24.08
217HS2064	5/16"	.3125	18"	14"	1	\$34.79
217HS2464	3/8"	.3750	18"	14"	1	\$48.08
217HS3064	15/32"	.4688	18"	14"	1	\$74.67
217HS3264	1/2"	.5000	18"	14"	1	\$80.63
217HS4064	5/8"	.6250	18"	14"	1	\$100.94
217HS4864	3/4"	.7500	18"	14"	1	\$128.81

MAIN OFFICE
 INTERNATIONAL TOOL MANUFACTURING
 71-08 51ST. AVENUE, WOODSIDE, NY 11377
 (718) 446-0711 - (800) 247-5696 - FAX (718) 899-6553



INTERNATIONAL TOOL MANUFACTURING
 675-E-PROGRESS CENTER AVE., LAWRENCEVILLE, GA 30043
 (770) 962-5454 - (800) 229-1776 - FAX (770) 962-5869

Made In



• ADJUSTABLE DEPTH



• ADJUSTABLE DEPTH

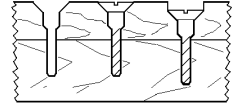

Drills, Countersinks, Counterbores in one operation. For every wood screw: Flat, Round, & Oval head.

For use with electric or hand drills on wood, plastic, or soft metal. For screw sizes #6, #8, #10, #12.

Screw Pilot - ROUND Shank

Part #	Description	List
310SPR006	#6 Screw Pilot Round Shank	\$4.59
310SPR008	#8 Screw Pilot Round Shank	\$4.59
310SPR010	#10 Screw Pilot Round Shank	\$4.59
310SPR012	#12 Screw Pilot Round Shank	\$4.59

Screw Pilot - HEX Shank

Part #	Description	List
312SPX006	#6 Screw Pilot HEX Shank	\$5.58
312SPX008	#8 Screw Pilot HEX Shank	\$5.58
312SPX010	#10 Screw Pilot HEX Shank	\$5.58
312SPX012	#12 Screw Pilot HEX Shank	\$5.58

Plug Cutter - Round Shank

Part #	Size	Cut Depth	Shank	List
311CUT014	1/4"	1"	1/4"	\$6.74
311CUT038	3/8"	1"	1/4"	\$7.29
311CUT012	1/2"	1"	1/4"	\$7.91
311CUT058	5/8"	1"	1/4"	\$8.98

Plug Cutter - Hex Shank

Part #	Size	Cut Depth	Shank	List
311HEX014	1/4"	1"	1/4"	\$7.75
311HEX038	3/8"	1"	1/4"	\$8.38
311HEX012	1/2"	1"	1/4"	\$9.10
311HEX058	5/8"	1"	1/4"	\$10.33



WOOD ONLY

Made In



- ◆ Precision Ground
- ◆ Hardened
- ◆ High Performance
- ◆ Sold Individually



Brad Point Wood Drill

Part #	Size	O/A	Shank	Qty.	List
309BP0864	1/8"	2-1/2"	1/8"	1	\$2.21
309BP1064	5/32"	3-1/8"	5/32"	1	\$2.42
309BP1264	3/16"	3-3/8"	3/16"	1	\$2.45
309BP1664	1/4"	4"	1/4"	1	\$2.67
309BP2064	5/16"	4-5/8"	5/16"	1	\$3.37
309BP2464	3/8"	4-7/8"	3/8"	1	\$3.83
309BP2864	7/16"	5-1/2"	3/8"	1	\$5.42
309BP3264	1/2"	6"	3/8"	1	\$6.98
309BP4064	5/8"	7"	3/8"	1	\$10.09
309BP4864	3/4"	7-3/4"	3/8"	1	\$14.82
309BP5664	7/8"	8-1/8"	3/8"	1	\$20.34
309BP6464	1"	8-1/2"	3/8"	1	\$27.40

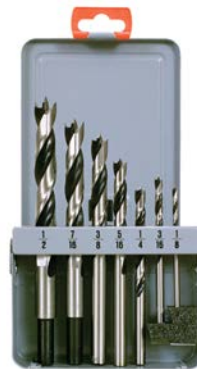

Part # 309BP007
7 Pc. Set Woodworking
 1/8"- 3/16"- 1/4"- 5/16"- 3/8"-
 7/16" - 1/2"
List Price Each \$32.48

- ◆ Precision Ground
- ◆ Center Spur
- ◆ Two Shoulder Cutting Spurs
- ◆ Fluted Bit
- ◆ Industrial Quality

NEW



- ◆ Cold Forged
- ◆ Full Length Treated
- ◆ Machine Finish Cutting Groove
- ◆ Rust Protection
- ◆ Wing Tip Design
- ◆ 1/4" Hex Power Groove Shank
- ◆ Individually Stamped With Size
- ◆ Industrial Quality

ALL SPADE POINT POWER DRILL BITS ARE SOLD INDIVIDUALLY. 1 PER POUCH.

1/4" Hex Power Groove Shank

- ◆ Quick-Change
- ◆ 1 PC. Construction
- ◆ 1/4" Hex Power Groove Shank
- ◆ Industrial Quality

Quick insert / quick spring out chuck extensions. Sold Individually

6" Long Spade Wood Drill

Part #	Size	O/A	Qty.	List
300SB1664	1/4"	6"	1	\$3.27
300SB2064	5/16"	6"	1	\$3.27
300SB2464	3/8"	6"	1	\$3.27
300SB2864	7/16"	6"	1	\$3.27
300SB3264	1/2"	6"	1	\$3.27
300SB3664	9/16"	6"	1	\$3.89
300SB4064	5/8"	6"	1	\$3.89
300SB4464	11/16"	6"	1	\$3.89
300SB4864	3/4"	6"	1	\$3.89
300SB5264	13/16"	6"	1	\$3.89
300SB5664	7/8"	6"	1	\$4.04
300SB6064	15/16"	6"	1	\$4.04
300SB6464	1"	6"	1	\$4.04
300SB7264	1-1/8"	6"	1	\$5.87
300SB8064	1-1/4"	6"	1	\$5.87
300SB8864	1-3/8"	6"	1	\$5.87
300SB9664	1-1/2"	6"	1	\$5.87



Part # 300-ST-06
6 Pc. Spade Bit Set
 3/8" - 1/2" - 5/8"
 3/4" - 7/8" - 1"

List Price
Each \$16.96

16" Long Spade Wood Drill

Part #	Size	O/A	Qty.	List
301SB1664	1/4"	16"	1	\$8.50
301SB2464	3/8"	16"	1	\$8.50
301SB3264	1/2"	16"	1	\$8.50
301SB4064	5/8"	16"	1	\$8.85
301SB4464	11/16"	16"	1	\$8.85
301SB4864	3/4"	16"	1	\$10.20
301SB5664	7/8"	16"	1	\$10.20
301SB6464	1"	16"	1	\$11.20
301SB8864	1-3/8"	16"	1	\$12.71



1/4" Hex Power Groove Shank

Extension - For Spade Bit

Part #	Size	For Shank	Ø	List
EXT-300	1/4" x 12"	1/4"	5/8"	\$13.50
EXT-500	1/4" x 18"	1/4"	5/8"	\$15.50



Straight Shank Extensions P.57



Single Spur - Double Twist Wood Drill

ELECTRICIAN'S POWER BITS

These power bits are specifically designed to fit in between building studs for the installation of conduits and wires. Ideal use is with angle power drills.

Packaged with a rust protection sleeve. Sold Individually.

Part #	Size	O/A	Shank	List
304BU4064	5/8"	8-1/2"	5/16"	\$32.08
304BU4464	11/16"	8-1/2"	5/16"	\$34.15
304BU4864	3/4"	8-1/2"	5/16"	\$35.61
304BU5264	13/16"	8-1/2"	5/16"	\$39.84
304BU5664	7/8"	8-1/2"	5/16"	\$41.26
304BU6464	1"	8-1/2"	5/16"	\$49.10
304BU7264	1-1/8"	8-1/2"	7/16"	\$52.89
304BU8064	1-1/4"	8-1/2"	7/16"	\$59.95

- ◆ 8-1/2" Length
- ◆ 5-1/2" Twist Length
- ◆ Heat Treated
- ◆ Machine Ground Hollows
- ◆ Self-Feeding Screw Point
- ◆ Shank With 2 Set Screw Recesses For Use with Power Bit Extensions



Double Spur - Double Twist Wood Drill

PLUMBER POWER BITS

These power bits are specifically designed for boring holes where a smooth finish is required. Ideal for plumbing, heating, air conditioning, and other pipe installation.

Packaged with a rust protection sleeve. Sold Individually.

Part #	Size	O/A	Shank	List
305BU4864	3/4"	6-1/2"	7/16"	\$32.78
305BU5664	7/8"	6-1/2"	7/16"	\$39.16
305BU6464	1"	6-1/2"	7/16"	\$45.30
305BU7264	1-1/8"	6-1/2"	7/16"	\$52.12
305BU8064	1-1/4"	6-1/2"	7/16"	\$56.47
305BU8864	1-3/8"	6-1/2"	7/16"	\$66.85
305BU9664	1-1/2"	6-1/2"	7/16"	\$72.89

- ◆ 6-1/2" Length
- ◆ 4" Twist Length
- ◆ Heat Treated
- ◆ Machine Ground Hollows
- ◆ Self-Feeding Screw Point
- ◆ Shank With 2 Set Screw Recesses For Use with Power Bit Extensions



- ◆ Carbide Tipped
- ◆ Hex Shank
- ◆ Heat Treated
- ◆ Machine Ground Hollows
- ◆ Deep Throat
- ◆ Single Twist
- ◆ Single Cutter
- ◆ Side Lip
- ◆ Power Groove
- ◆ Self-Feeding Screw Point

Made In



ALL POWER POLE AUGER DRILL BITS ARE SOLD INDIVIDUALLY.

Power Pole Auger Wood Drills

Part #	Size	O/A	Drilling	Shank	List
CPP-10716	7/16"	18"	15"	7/16"	\$99.63
CPP-11121	1/2"	18"	15"	7/16"	\$77.17
CPP-12122	1/2"	24"	21"	7/16"	\$85.10
CPP-13123	1/2"	36"	33"	7/16"	\$163.22
CPP-14911	9/16"	18"	15"	7/16"	\$87.75
CPP-15912	9/16"	24"	21"	7/16"	\$95.76
CPP-16913	9/16"	36"	33"	7/16"	\$171.08
CPP-17581	5/8"	18"	15"	7/16"	\$86.75
CPP-18582	5/8"	24"	21"	7/16"	\$99.09
CPP-19583	5/8"	36"	33"	7/16"	\$176.53
CPP-20161	11/16"	18"	15"	7/16"	\$87.48
CPP-21162	11/16"	24"	21"	7/16"	\$104.61
CPP-22163	11/16"	36"	33"	7/16"	\$190.29
CPP-23241	3/4"	18"	15"	7/16"	\$91.73
CPP-24342	3/4"	24"	21"	7/16"	\$102.50
CPP-25343	3/4"	36"	33"	7/16"	\$191.51
CPP-26131	13/16"	18"	15"	7/16"	\$93.84
CPP-27132	13/16"	24"	21"	7/16"	\$111.67
CPP-28133	13/16"	36"	33"	7/16"	\$215.78
CPP-29781	7/8"	18"	15"	7/16"	\$105.19
CPP-30782	7/8"	24"	21"	7/16"	\$116.65
CPP-31783	7/8"	36"	33"	7/16"	\$225.44
CPP-32561	15/16"	18"	15"	7/16"	\$108.14
CPP-33562	15/16"	24"	21"	7/16"	\$125.62
CPP-34563	15/16"	36"	33"	7/16"	\$233.95
CPP-35115	1"	18"	15"	7/16"	\$110.52
CPP-36121	1"	24"	21"	7/16"	\$128.80
CPP-37133	1"	36"	33"	7/16"	\$238.17

Use with 1/2" Drills or Impact Wrenches:

- Stanley ID-04 "Yellow Jacket"
- Racine HIW-716
- Fairmount H8508

Also works well in heavy duty electric, pneumatic, and gas powered drills.



Power Pole Auger Drill Bits are carbide tipped wood drill bits that have a carbide-tipped cutting tip combined with a hardened steel cutting edge. These unique carbide tipped wood drill bits bore holes in all types of wood quickly, leaving little or no residue. A truly clean, smooth hole is produced. Power Pole carbide tipped wood auger drill bits require less torque to operate and can be used with electric, air, or gasoline powered drill motors and impact wrenches.

Made of premium steel, Power Pole Auger Bits are for boring CCA and Creosoted poles, railroad ties, bulkheads, and other heavy timber.

MAIN OFFICE
 INTERNATIONAL TOOL MANUFACTURING
 71-08 51ST. AVENUE, WOODSIDE, NY 11377
 (718) 446-0711 - (800) 247-5696 - FAX (718) 899-6553



INTERNATIONAL TOOL MANUFACTURING
 675-E-PROGRESS CENTER AVE., LAWRENCEVILLE, GA 30043
 (770) 962-5454 - (800) 229-1776 - FAX (770) 962-5869



8" Long Ship Auger Wood Drill

Part #	Size	Size In 16ths	O/A	Hex Shank	List
302SL3264	1/2"	8	8"	5/16"	\$27.82
302SL3664	9/16"	9	8"	5/16"	\$27.82
302SL4064	5/8"	10	8"	5/16"	\$27.82
302SL4464	11/16"	11	8"	5/16"	\$28.66
302SL4864	3/4"	12	8"	5/16"	\$29.53
302SL5264	13/16"	13	8"	5/16"	\$34.41
302SL5664	7/8"	14	8"	7/16"	\$35.55
302SL6064	15/16"	15	8"	7/16"	\$43.06
302SL6464	1"	16	8"	7/16"	\$43.95
302SL7264	1-1/8"	18	8"	7/16"	\$48.90
302SL8064	1-1/4"	20	8"	7/16"	\$56.65
302SL8864	1-3/8"	20	8"	7/16"	\$71.24
302SL9664	1-1/2"	24	8"	7/16"	\$73.90

- ◆ 6" Twist Length
- ◆ Heat Treated
- ◆ Machine Ground Hollows
- ◆ Deep Throat
- ◆ Single Twist
- ◆ Single Cutter
- ◆ Side Lip
- ◆ Self-Feeding Screw Point

ALL SHIP AUGER DRILL
 BITS ARE SOLD
 INDIVIDUALLY.



18" Long Ship Auger Wood Drill

Part #	Size	Size In 16ths	O/A	Hex Shank	List
303SL2464	3/8"	6	18"	5/16"	\$34.20
303SL2864	7/16"	7	18"	5/16"	\$34.20
303SL3264	1/2"	8	18"	5/16"	\$34.20
303SL3664	9/16"	9	18"	7/16"	\$34.20
303SL4064	5/8"	10	18"	7/16"	\$34.20
303SL4464	11/16"	11	18"	7/16"	\$37.57
303SL4864	3/4"	12	18"	7/16"	\$37.59
303SL5264	13/16"	13	18"	7/16"	\$41.76
303SL5664	7/8"	14	18"	7/16"	\$43.72
303SL6064	15/16"	15	18"	7/16"	\$47.81
303SL6464	1"	16	18"	7/16"	\$48.58
303SL7264	1-1/8"	18	18"	7/16"	\$57.46
303SL8064	1-1/4"	20	18"	7/16"	\$66.91
303SL8864	1-3/8"	22	18"	7/16"	\$74.54
303SL9664	1-1/2"	24	18"	7/16"	\$78.90

- ◆ 12" Twist Length
- ◆ Heat Treated
- ◆ Machine Ground Hollows
- ◆ Deep Throat
- ◆ Single Twist
- ◆ Single Cutter
- ◆ Side Lip
- ◆ Self-Feeding Screw Point



Made of premium steel, Ship Auger Bits are for boring creosoted poles, railroad ties, bulkheads, and other heavy timber.



Forstner Wood Drill

3-1/2" LONG UP TO 2-1/8" DIA.
 6" LONG FROM 2-1/4" DIA.

*Sharp edges for
 precise holes.*

- ◆ Cold Forged
- ◆ Full Length Treated
- ◆ Machine Finish Cutting Groove
- ◆ Rust Protection
- ◆ Wing Tip Design
- ◆ Precision Ground HEX Shank
- ◆ Individually Stamped With Size
- ◆ Industrial Quality

Part #	Size	Shank	Qty.	List	Part #	Size	Shank	Qty.	List
310FB1664	1/4"	3/8"	1	\$7.69	310F11264	*1-3/4"	3/8"	1	\$29.57
310FB2464	3/8"	3/8"	1	\$8.80	310F12064	*1-7/8"	3/8"	1	\$29.84
310FB3264	1/2"	3/8"	1	\$9.18	310F12864	*2"	3/8"	1	\$32.63
310FB4064	5/8"	3/8"	1	\$9.69	310F13664	*2-1/8"	3/8"	1	\$38.88
310FB4864	3/4"	3/8"	1	\$11.76	310F14464	*2-1/4"	1/2"	1	\$50.13
310FB5664	7/8"	3/8"	1	\$11.95	310F15264	*2-3/8"	1/2"	1	\$56.26
310FB6464	1"	3/8"	1	\$13.22	310F16064	*2-1/2"	1/2"	1	\$59.43
310FB7264	*1-1/8"	3/8"	1	\$14.16	310F16864	*2-5/8"	1/2"	1	\$61.86
310FB8064	*1-1/4"	3/8"	1	\$15.62	310F17664	*2-3/4"	1/2"	1	\$67.95
310FB8864	*1-3/8"	3/8"	1	\$20.09	310F18464	*2-7/8"	1/2"	1	\$77.68
310FB9664	*1-1/2"	3/8"	1	\$21.06	310F19264	*3"	1/2"	1	\$89.85
310F10464	*1-5/8"	3/8"	1	\$24.75	310F20064	*3-1/8"	1/2"	1	\$99.56

* Sizes 1-1/8" and Over Have Multi Spur Cutting Edge.

ALL FORSTNER
 DRILL BITS
 ARE SOLD
 INDIVIDUALLY.
 1 PER PACK



4" Extension

PART # 310EX0100

**4" Extension For
 Forstner Woodboring Drills**
 For 3/8" Shanks Only!

List \$10.40



16 Pc. Forstner Set

PART # 310FB0016

Forstner Woodboring Drill Set
 16 Piece Set

SIZES 1/4", 3/8", 1/2", 5/8", 3/4", 7/8", 1",
 1-1/8", 1-1/4", 1-3/8", 1-1/2", 1-5/8", 1-3/4",
 1-7/8", 2", 2-1/8"

List \$135.00

MAIN OFFICE
 INTERNATIONAL TOOL MANUFACTURING
 71-08 51ST. AVENUE, WOODSIDE, NY 11377
 (718) 446-0711 - (800) 247-5696 - FAX (718) 899-6553



INTERNATIONAL TOOL MANUFACTURING
 675-E-PROGRESS CENTER AVE., LAWRENCEVILLE, GA 30043
 (770) 962-5454 - (800) 229-1776 - FAX (770) 962-5869

NEW

Self Feed (Multispur) Wood Drill

Part #	Size	MM	Pipe Entrance	Tubing Entrance	Cutting Flute	Shank	List
306ST-1	1"	25.4	1/2"	7/8"	1	7/16"	\$40.25
306ST-2	1-1/8"	28.6	1/2"	1"	1	7/16"	\$40.25
306ST-3	1-1/4"	31.8	3/4"	1-1/8"	1	7/16"	\$40.25
306ST-4	1-3/8"	34.9	1"	1-1/4"	1	7/16"	\$40.25
306ST-5	1-1/2"	38.1	1"	1-3/8"	1	7/16"	\$40.25
306ST-6	1-3/4"	44.5	1-1/4"	1-1/2"	1	7/16"	\$43.19
306ST-7	2"	50.8	1-1/2"	1-7/8"	1	7/16"	\$46.14
306ST-8	2-1/8"	54.0	1-1/2"	2"	1	7/16"	\$47.19
306ST-9	2-1/4"	57.2	1-1/2"	2-1/8"	1	7/16"	\$51.19
306ST-10	2-9/16"	65.1	2"	2-1/2"	1	7/16"	\$51.58
306ST-11	3"	76.2	2-1/2"	2-7/8"	2	7/16"	\$132.94
306ST-12	3-5/8"	92.1	3"	3-1/2"	2	7/16"	\$180.78
306ST-13	4-5/8"	117.5	4"	4-1/2"	2	7/16"	\$212.75



ALL MULTISPUR & FORSTNER BITS SOLD INDIVIDUALLY

Replacement Screw Points

Part #	Size	Fits	List
SP0001	1/4"	1-1/4" to 2-9/16"	\$6.75
SP0002	1/4"	3" to 4-5/8"	\$10.13

Screw Points come with replacement set screw and wrench.



- ◆ Fast Continuous Self Feeding
- ◆ Deep Holes
- ◆ 7/16" Impact Hex Shank
- ◆ Double End Screw
- ◆ Extra Screw & Wrench

- Wood
- Plumbing
- Rough-in Work



Extensions for Ship Auger & Multispur

POWER BIT EXTENSIONS

Part #	Size	For Shank	Ø	List
307BT1214	1/4 x 12 Extension	1/4"	9/16"	\$12.10
307BT1418	1/4 x 18 Extension	1/4"	9/16"	\$22.08
307BT5618	5/16 x 18 Extension	5/16"	11/16"	\$20.66
307BT5624	5/16 x 24 Extension	5/16"	11/16"	\$28.17
307BT7609	7/16 x 9 1/2 Extensions	7/16"	7/8"	\$21.69

Part #	Size	For Shank	Ø	List
307BT7612	7/16 x 12 Extensions	7/16"	7/8"	\$21.69
307BT7618	7/16 x 18 Extensions	7/16"	7/8"	\$25.14
307BT7624	7/16 x 24 Extensions	7/16"	7/8"	\$31.45

- ◆ HEX Wrench included
- ◆ 2 Set Screws

Circular Saw Blades

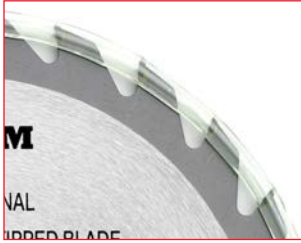

- ◆ Hard Body 38-42 Rc.
- ◆ K20 Tungsten Carbide Grade
- ◆ Individually Protected
- ◆ Individually Barcoded
- ◆ Imported



BARCODED

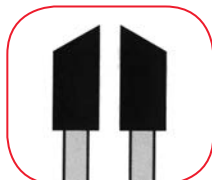

**ALTERNATE TOP
 BEVELED TEETH**

- **Cut Faster!**
- **Cut Cleaner!**
- **Lasts Longer!**



7-1/4" x 24T - **ULTRA** Thin Kerf

Part # UT-58-724

List \$13.30

- Tungsten Carbide Tipped
- 5/8" Arbor with Diamond Knock-Out.
- 7,000 RPM Maximum
- Sold 25 / Display Box



7-1/4" x 24T - **STANDARD** Thin Kerf

Part # DS-58-724

List \$12.49

- Tungsten Carbide Tipped
- 5/8" Arbor with Diamond Knock-Out.
- 7,000 RPM Maximum
- Sold 25 / Display Box

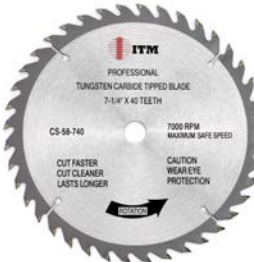

7-1/4" x 40T - Thin Kerf

Part # CS-58-740

List \$28.85

- Tungsten Carbide Tipped
- 5/8" Arbor with Diamond Knock-Out.
- 7,000 RPM Maximum
- Sold 25 / Display Box



8-1/4" x 24T - Thin Kerf

Part # CS-58-824

List \$23.28

- Tungsten Carbide Tipped
- 5/8" Arbor with Diamond Knock-Out.
- 7,000 RPM Maximum
- Sold 10 / Display Box



8-1/4" x 40T - Thin Kerf

Part # CS-58-840

List \$34.73

- Tungsten Carbide Tipped
- 5/8" Arbor with Diamond Knock-Out.
- 7,000 RPM Maximum
- Sold 10 / Display Box

Industrial Wire Brushes

Part #	Size	Wire	Material	List
KCC075	2-3/4"	Knotted Cup	Carbon Steel	\$12.50
KCS075	2-3/4"	Knotted Cup	STAINLESS Steel	\$18.00
KCC100	4"	Knotted Cup	Carbon Steel	\$18.06
KCC150	6"	Knotted Cup	Carbon Steel	\$37.22
<hr/>				
CCC075	3"	Crimped Cup	Carbon Steel	\$11.81
CCC100	4"	Crimped Cup	Carbon Steel	\$17.22
<hr/>				
TKW100	4"	Twist knot Wheel	Carbon Steel	\$14.44
<hr/>				
SBW100	4"	Stringer Bead Wheel	Carbon Steel	\$14.72
SBS100	4"	Stringer Bead Wheel	STAINLESS Steel	\$31.67
SBW150	6"	Stringer Bead Wheel	Carbon Steel	\$42.71
<hr/>				
WBB120	12"	Walk Behind Wire Brush	Carbon Steel 1" Spindle	\$98.25
<hr/>				
VIP100		Hand Wire Brush	Carbon Steel	\$5.56

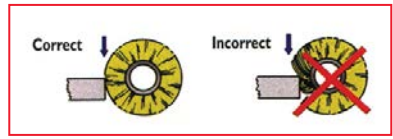

- ◆ Sold In Individual Boxes
- ◆ Industrial Quality
- ◆ Made In Taiwan

◆ 5/8" - 11 SPINDLE



APPLICATION	KNOTTED CUP WIRE BRUSH	CRIMPED CUP WIRE BRUSH	TWIST KNOT WIRE BRUSH	STRINGER BEAD WIRE BRUSH
DEBURRING (FINE)	✘	✘		
DEBURRING (COURSE)			✘	✘
EDGE BLENDING	✘	✘		
WELD, SCALE REMOVAL			✘	✘
WELD PREP				✘
SURFACE FINISHING	✘	✘		
RUST OXIDE (FINE)	✘	✘		
RUST OXIDE (COARSE)			✘	✘
PAINT REMOVAL	✘	✘		
ROUGHENING	✘	✘	✘	✘
CLEANING	✘	✘		✘
FLASH REMOVAL		✘	✘	
TOOL MARK REMOVAL		✘	✘	
EXPANSION JOINT		✘	✘	

STAINLESS STEEL BRUSHES ARE BEST FOR:

- Stainless Steel
- Aluminum
- Non-Ferrous Alloy Metals



1 HOLE SAW PER BOX.
 ARBOR NOT INCLUDED.

These High Quality Bi-Metal Hole Saws are made by a very special process. The cutting edge is electron beam welded to a tough alloy steel back. These hole saws are ideal for work where high performance & accuracy are needed. Saws have knock-out holes for easy core removal.

Made In



- ◆ Made In USA
- ◆ Bi-Metal Construction
- ◆ M3 Cutting Edge
- ◆ 4/6 Variable Pitch. Rc. 63-65
- ◆ Positive Rake
- ◆ 1-1/2" Cutting Depth
- ◆ Premium Quality
- ◆ Cuts Through 2" x 4"s
- ◆ Red Finish

- Wood
- Plastic
- Machinable Metal
- Nail Embedded Wood
- Plywood
- Pipes
- Stainless Steel

* USE ARBORS 276AR0001 or 276AR0002.
 ** USE ARBORS 276AR0003 or 276AR0035.

Bi-Metal Hole Saws - Variable Pitch

Part #	Dia.		PIPE TAP SIZE		PIPE ENT. SIZE		Use	
	Inches	MM	Inches	MM	Inches	MM	Arbor	List
275HW0011	9/16"	14.3	3/8"				*	\$14.58
275HW0012	5/8"	15.5					*	\$11.07
275HW0112	16mm	16.0					*	\$12.17
275HW0013	11/16"	17.5					*	\$11.07
275HW0014	3/4"	19.0	1/2"	13 mm	3/8"	10 mm	*	\$11.07
275HW0114	20mm	20.0					*	\$12.17
275HW0015	13/16"	20.6					*	\$11.07
275HW0016	7/8"	22.2	3/4"	19 mm	1/2"	13 mm	*	\$11.07
275HW0017	15/16"	23.8					*	\$11.07
275HW0117	25mm	25.0					*	\$12.91
275HW0018	1"	25.4					*	\$11.74
275HW0185	1-1/16"	27.0					*	\$11.74
275HW0019	1-1/8"	28.8	1"	25 mm	3/4"	19 mm	*	\$11.74
275HW0118	30mm	30.0					*	\$12.91
275HW0020	1-3/16"	30.2					*	\$11.74
275HW0021	1-1/4"	31.8					**	\$11.74
275HW0121	32mm	32.0					**	\$12.91
275HW0022	1-5/16"	33.3					**	\$11.74
275HW0023	1-3/8"	34.9			1"	25 mm	**	\$12.45
275HW0122	35mm	35.0					**	\$13.70
275HW0123	1-7/16"	36.5					**	\$12.45
275HW0024	1-1/2"	38.1	1-1/4"	32 mm			**	\$12.69
275HW0124	1-9/16"	39.7					**	\$12.69
275HW0224	40mm	40.0					**	\$14.13
275HW0025	1-5/8"	41.2					**	\$12.84
275HW0125	1-11/16"	42.9					**	\$12.84
275HW0026	1-3/4"	44.5	1-1/2"	38 mm	1-1/4"	32 mm	**	\$15.55
275HW0226	45mm	45.0					**	\$17.11
275HW0126	1-13/16"	46.0					**	\$15.55
275HW0027	1-7/8"	47.6					**	\$15.78
275HW0127	50mm	50.0					**	\$17.61
275HW0028	2"	50.8			1-1/2"	38 mm	**	\$16.01
275HW0128	2-1/16"	52.4					**	\$19.13
275HW0029	2-1/8"	53.9					**	\$19.13
275HW0129	55mm	55.0					**	\$21.04
275HW0030	2-1/4"	57.2	2"	51 mm			**	\$19.28
275HW0031	2-5/16"	58.7					**	\$19.45
275HW0032	2-3/8"	60.3					**	\$19.55
275HW0033	2-1/2"	63.5			2"	51 mm	**	\$20.62
275HW0034	2-9/16"	65.1					**	\$20.74
275HW0134	2-5/8"	66.7	2-1/2"	64 mm			**	\$21.22
275HW0234	68mm	68.0					**	\$23.34
275HW0334	68.5mm	68.5					**	\$23.34
275HW0135	2-3/4"	69.9					**	\$21.22
275HW0136	2-7/8"	73.0					**	\$21.22
275HW0236	75mm	75.0					**	\$23.34
275HW0035	3"	76.2			2-1/2"	64 mm	**	\$21.22
275HW0137	3-1/8"	79.4					**	\$21.44
275HW0138	3-1/4"	82.6	3"	76 mm			**	\$21.44
275HW0139	3-3/8"	85.7					**	\$21.44
275HW0036	3-1/2"	88.9					**	\$21.44
275HW0140	3-5/8"	92.1					**	\$25.17
275HW0141	3-3/4"	95.3	3-1/2"	89 mm	3"	76 mm	**	\$29.57
275HW0142	3-7/8"	98.4					**	\$31.10
275HW0100	100mm	100.0					**	\$31.23
275HW0037	4"	101.6					**	\$32.44
275HW0143	4-1/8"	104.8			3-1/2"	89 mm	**	\$35.49
275HW0144	4-1/4"	108.0	4"	102 mm			**	\$46.19
275HW0038	4-1/2"	114.3			4"	102 mm	**	\$63.89
275HW0145	4-3/4"	120.7					**	\$74.03
275HW0039	5"	127.0					**	\$78.72
275HW0040	5-1/2"	139.7					**	\$93.93
275HW0146	5-3/4"	146.0					**	\$101.99
275HW0041	6"	152.4					**	\$110.04

MAIN OFFICE
 INTERNATIONAL TOOL MANUFACTURING
 71-08 51ST. AVENUE, WOODSIDE, NY 11377
 (718) 446-0711 - (800) 247-5696 - FAX (718) 899-6553



INTERNATIONAL TOOL MANUFACTURING
 675-E-PROGRESS CENTER AVE., LAWRENCEVILLE, GA 30043
 (770) 962-5454 - (800) 229-1776 - FAX (770) 962-5869



BI-METAL

**PART # 275AV02E
 ELECTRICIAN'S HOLE SAW KIT**

8 Pc. Set contains:
 1 each 7/8" - 1-1/8" - 1-3/8" - 1-3/4" - 2" - 2-1/2"
 2 Arbors - 276AR0002 - 276AR0003

PRICE EACH \$129.15



BI-METAL

**PART # 275AV100
 MAINTENANCE HOLE SAW KIT**

13 Pc. Set contains:
 1 each 3/4" - 7/8" - 1-1/8" - 1-3/8" - 1-1/2"
 -1-3/4" 2" - 2-1/4" - 2-1/2"
 3 Arbors - 276AR0001 - 276AR0002 - 276AR0003
 1 Extension.

PRICE EACH \$175.60



**PART # 275AT100
 CARBIDE TIPPED
 MAINTENANCE HOLE SAW KIT**

13 Pc. Set contains:
 1 each 3/4" - 7/8" - 1-1/8" - 1-3/8" - 1-1/2"
 -1-3/4" 2" - 2-1/4" - 2-1/2"
 3 each Arbors for above sizes. 1 Extension.

PRICE EACH \$334.86



BI-METAL

**PART # 275AV08E
 MASTER ELECTRICIAN'S HOLE
 SAW KIT**

13 Pc. Set contains:
 1 each 7/8" - 1-1/8" - 1-3/8" - 1-3/4" - 2" - 2-1/2"
 3" - 3-5/8" - 4-1/8" - 4-1/2"
 3 Arbors - 276AR0001 - 276AR0002 - 276AR0003

PRICE EACH \$261.98



BI-METAL

**PART # 275AV04P
 PLUMBER'S HOLE SAW KIT**

8 Pc. Set contains:
 1 each 3/4" - 7/8" - 1-1/8" - 1-1/2" - 1-3/4" -
 2-1/4"
 2 Arbors - 276AR0002 - 276AR0003

PRICE EACH \$124.34



**RECOMMENDED
 Bi-Metal HOLE SAW
 CUTTING SPEEDS IN RPM's**



- 1 **LUBRICANTS** - Use a good cutting oil for faster, more efficient cutting in ferrous metals. Cutting oil should not be used when cutting cast iron. Beeswax or paraffin is often used when cutting aluminum.
- 2 **CUTTING POSITION** - Do not cut materials at an angle. All the hole saw teeth should be in contact with the material to avoid tooth damage.
- 3 **FEEDS** - For effective cutting, apply level and even pressure. Excessive pressure results in premature wear, dulling of the teeth, and breakage. When cutting material over 1" thick, the saw should be pulled back at intervals to allow chip clearance.

SIZE	MILD STEEL	CAST IRON	TOOL & STAINLESS	BRASS	ALUMINUM
9/16"	580	400	300	790	900
5/8"	550	365	275	730	825
11/16"	500	330	250	665	750
3/4"	460	300	230	600	690
13/16"	425	280	210	560	635
7/8"	390	260	195	520	585
15/16"	370	245	185	495	555
1"	350	235	175	470	525
1 - 1/16"	325	215	160	435	480
1 - 1/8"	300	200	150	400	450
1 - 3/16"	285	190	145	380	425
1 - 1/4"	275	180	140	360	410
1 - 5/16"	260	175	135	345	390
1 - 3/8"	250	165	125	330	375
1 - 7/16"	240	160	120	315	360
1 - 1/2"	230	150	115	300	345
1 - 9/16"	220	145	110	290	330
1 - 5/8"	210	140	105	280	315
1 - 11/16"	205	135	100	270	305
1 - 3/4"	195	130	95	260	295
1 - 13/16"	190	125	95	250	285
1 - 7/8"	180	120	90	240	270
2"	170	115	85	230	255
2 - 1/16"	165	110	80	220	245
2 - 1/8"	160	105	80	210	240
2 - 1/4"	150	100	75	200	225
2 - 5/16"	145	100	75	195	225
2 - 3/8"	140	95	70	190	220
2 - 1/2"	135	90	65	180	205
2 - 9/16"	130	85	65	175	200
2 - 5/8"	130	85	65	170	195
2 - 3/4"	125	80	60	160	185
2 - 7/8"	120	80	60	160	180
3"	115	75	55	150	170
3 - 1/8"	110	70	55	140	165
3 - 1/4"	105	70	50	140	155
3 - 3/8"	100	65	50	130	150
3 - 1/2"	95	65	45	130	145
3 - 5/8"	95	60	45	120	140
3 - 3/4"	90	60	45	120	135
3 - 7/8"	90	60	45	120	135
4"	85	55	40	110	130
4 - 1/8"	80	55	40	110	120
4 - 1/4"	80	55	40	110	120
4 - 1/2"	75	50	35	100	105
4 - 3/4"	75	50	35	95	95
5"	65	45	30	90	90
5 - 1/2"	60	40	25	85	85
5 - 3/4"	55	35	25	75	75
6"	55	35	25	75	75



1 HOLE SAW PER BOX.
 ARBOR NOT INCLUDED.

These High Quality Carbide Tipped Hole Saws are designed for use in abrasive materials such as particle board, fiberglass, cast iron, asbestos board, and formica. They are ideal for work where high performance & accuracy are needed. Saws have knock-out holes for easy core removal.

Made In



- ◆ Made In USA
- ◆ Tungsten Carbide Teeth
- ◆ Ground & Welded Set Teeth
- ◆ 3 Teeth Per Inch
- ◆ High Wear Resistance
- ◆ 1-1/2" Cutting Depth
- ◆ Premium Quality
- ◆ Cuts Material Bi-Metal will not Cut
- ◆ Black Finish

- Particle Board
- Fiberglass
- Cast Iron
- Asbestos Board
- Formica

* USE ARBORS 276AR0001 or 276AR0002.
 ** USE ARBORS 276AR0003 or 276AR00035.

Carbide Tipped Hole Saws

Part #	Dia. Inches	Dia. MM	PIPE TAP SIZE		PIPE ENT. SIZE		Use	
			Inches	MM	Inches	MM	Arbor	List
AT120034	3/4"	19.0	1/2"	13 mm	3/8"	10 mm	*	\$17.71
AT131316	13/16"	20.6					*	\$18.10
AT140078	7/8"	22.2	3/4"	19 mm	1/2"	13 mm	*	\$18.25
AT151516	15/16"	23.8					*	\$18.93
AT160001	1"	25.4					*	\$19.47
AT171116	1-1/16"	27.0					*	\$20.15
AT180118	1-1/8"	28.8	1"	25 mm	3/4"	19 mm	*	\$20.64
AT191316	1-3/16"	30.2					*	\$21.37
AT200114	1-1/4"	31.8					**	\$21.46
AT211516	1-5/16"	33.3					**	\$21.61
AT220138	1-3/8"	34.9			1"	25 mm	**	\$21.80
AT231716	1-7/16"	36.5					**	\$21.85
AT240112	1-1/2"	38.1	1-1/4"	32 mm			**	\$22.34
AT251916	1-9/16"	39.7					**	\$23.17
AT260158	1-5/8"	41.2					**	\$23.70
AT271116	1-11/16"	42.9					**	\$24.24
AT280134	1-3/4"	44.5	1-1/2"	38 mm	1-1/4"	32 mm	**	\$24.82
AT291316	1-13/16"	46.0					**	\$25.36
AT300178	1-7/8"	47.6					**	\$25.89
AT320002	2"	50.8			1-1/2"	38 mm	**	\$26.62
AT332116	2-1/16"	52.4					**	\$30.81
AT340218	2-1/8"	53.9					**	\$31.34
AT360214	2-1/4"	57.2	2"	51 mm			**	\$32.41
AT372516	2-5/16"	58.7					**	\$33.05
AT380238	2-3/8"	60.3					**	\$33.48
AT400212	2-1/2"	63.5			2"	51 mm	**	\$35.04
AT412916	2-9/16"	65.1					**	\$35.62
AT420258	2-5/8"	66.7	2-1/2"	64 mm			**	\$36.16
AT440234	2-3/4"	69.9					**	\$37.28
AT460278	2-7/8"	73.0					**	\$38.40
AT480003	3"	76.2			2-1/2"	64 mm	**	\$39.47
AT500318	3-1/8"	79.4					**	\$47.50
AT520314	3-1/4"	82.6	3"	76 mm			**	\$48.76
AT540338	3-3/8"	85.7					**	\$51.83
AT560312	3-1/2"	88.9					**	\$52.51
AT580358	3-5/8"	92.1			3"	76 mm	**	\$53.63
AT600334	3-3/4"	95.3	3-1/2"	89 mm			**	\$55.14
AT620378	3-7/8"	98.4					**	\$56.21
AT640004	4"	101.6					**	\$58.60
AT660418	4-1/8"	104.8			3-1/2"	89 mm	**	\$81.37
AT680414	4-1/4"	108.0	4"	102 mm			**	\$84.29
AT700438	4-3/8"	111.0					**	\$85.36
AT720412	4-1/2"	114.3			4"	102 mm	**	\$85.80
AT760434	4-3/4"	120.7					**	\$93.44
AT800005	5"	127.0					**	\$96.17
AT880512	5-1/2"	139.7					**	\$101.28
AT920534	5-3/4"	146.0					**	\$111.33
AT960006	6"	152.4					**	\$118.05

CARBIDE TIPPED RPM CHART

SIZE	ALUMINUM	PLASTIC	FIBER-GLASS	CERAMIC TILE	PARTICLE BOARD	CAST IRON	FORMICA
3/4"	1700	3430	250	500	3430	410	210
7/8"	1500	2940	210	430	2940	350	180
1"	1300	2570	190	370	2570	310	150
1-1/8"	1100	2290	170	330	2290	270	140
1-3/8"	900	1870	140	270	1870	220	110
1-1/2"	900	1710	120	250	1710	210	100
1-3/4"	700	1470	110	210	1470	180	90
2"	600	1290	90	190	1290	150	80
2-1/4"	600	1140	80	170	1140	140	70
2-1/2"	500	1030	70	150	1030	120	60
3"	400	860	60	120	860	100	50
3-1/4"	400	790	60	110	790	90	50
3-5/8"	400	710	50	100	710	90	40
3-3/4"	300	690	50	100	690	80	40
4-1/8"	300	620	50	90	620	70	40
4-3/4"	300	540	40	80	540	60	30
5"	200	480	40	80	500	60	30
5-1/2"	200	420	40	70	460	50	30
6"	100	360	30	60	420	40	30

Carbide Grit Hole Saws

Part #	Dia. Inches	Dia. MM	PIPE TAP SIZE		PIPE ENT. SIZE		Use	
			Inches	MM	Inches	MM	Arbor	List
CG0012	3/4"	19.0	1/2"	13 mm	3/8"	10 mm	*	\$37.78
CG0013	13/16"	20.6					*	\$37.78
CG0014	7/8"	22.2	3/4"	19 mm	1/2"	13 mm	*	\$37.78
CG0015	15/16"	23.8					*	\$37.78
CG0016	1"	25.4					*	\$41.28
CG0017	1-1/16"	27.0					*	\$41.28
CG0018	1-1/8"	28.8	1"	25 mm	3/4"	19 mm	*	\$41.28
CG0019	1-3/16"	30.2					*	\$41.28
CG0020	1-1/4"	31.8					**	\$42.35
CG0021	1-5/16"	33.3					**	\$42.35
CG0022	1-3/8"	34.9			1"	25 mm	**	\$42.70
CG0023	1-7/16"	36.5					**	\$42.70
CG0024	1-1/2"	38.1	1-1/4"	32 mm			**	\$42.70
CG0025	1-9/16"	39.7					**	\$42.70
CG0026	1-5/8"	41.2					**	\$42.70
CG0027	1-11/16"	42.9					**	\$42.70
CG0028	1-3/4"	44.5	1-1/2"	38 mm	1-1/4"	32 mm	**	\$52.39
CG0029	1-13/16"	46.0					**	\$52.39
CG0030	1-7/8"	47.6					**	\$52.39
CG0032	2"	50.8			1-1/2"	38 mm	**	\$52.39
CG0033	2-1/16"	52.4					**	\$52.39
CG0034	2-1/8"	53.9					**	\$61.98
CG0036	2-1/4"	57.2	2"	51 mm			**	\$61.98
CG0037	2-5/16"	58.7					**	\$61.98
CG0038	2-3/8"	60.3					**	\$61.98
CG0040	2-1/2"	63.5			2"	51 mm	**	\$69.87
CG0041	2-9/16"	65.1					**	\$69.87
CG0042	2-5/8"	66.7	2-1/2"	64 mm			**	\$69.87
CG0044	2-3/4"	69.9					**	\$69.87
CG0046	2-7/8"	73.0					**	\$69.87
CG0048	3"	76.2			2-1/2"	64 mm	**	\$84.67
CG0050	3-1/8"	79.4					**	\$84.67
CG0052	3-1/4"	82.6	3"	76 mm			**	\$84.67
CG0054	3-3/8"	85.7					**	\$84.67
CG0056	3-1/2"	88.9					**	\$89.91
CG0058	3-5/8"	92.1			3"	76 mm	**	\$96.75
CG0060	3-3/4"	95.3	3-1/2"	89 mm			**	\$104.80
CG0062	3-7/8"	98.4					**	\$108.24
CG0064	4"	101.6					**	\$111.87
CG0066	4-1/8"	104.8			3-1/2"	89 mm	**	\$119.46
CG0068	4-1/4"	108.0	4"	102 mm			**	\$125.45
CG0070	4-3/8"	111.0					**	\$131.70
CG0072	4-1/2"	114.3			4"	102 mm	**	\$137.58
CG0076	4-3/4"	120.7					**	\$147.22
CG0080	5"	127.0					**	\$157.51
CG0088	5-1/2"	139.7					**	\$168.55
CG0092	5-3/4"	146.0					**	\$168.55
CG0096	6"	152.4					**	\$168.55



1 HOLE SAW PER BOX.
 ARBOR NOT INCLUDED.



These High Quality Carbide Grit Hole Saws are designed for use in hard or abrasive materials such as ceramics, fiberglass, hard woods, cast iron, & composites. They are best suited for thin materials that would strip bi-metal or carbide teeth. Saws have knock-out holes for easy core removal. Use a carbide tipped pilot arbor when drilling into ceramics.

Made In



- ◆ Made In USA
- ◆ Tungsten Carbide Grit
- ◆ Bonded to Alloy Back
- ◆ Gulletted Edge
- ◆ Super Wear Resistance
- ◆ 1-3/8" Cutting Depth
- ◆ Premium Quality
- ◆ Cuts Material Bi-Metal Cannot Cut
- ◆ Black Finish

- Ceramics
- Fiberglass
- Cast Iron
- Hard Woods
- Composites



CARBIDE GRIT

RECESSED LIGHTING HOLE SAWS

PART NUMBER	SIZE	PRICE EACH
CG0104	6-3/8"	\$177.95
CG0106	6-5/8"	\$177.95
CG0110	6-7/8"	\$177.95

* USE ARBORS 276AR0001, 276AR0002, or 276CT0034.
 ** USE ARBORS 276AR0003, 276AR0035 or 276CT0045.

1/4" Pilot Drills



PART #
277PD0014
 1/4" HSS PILOT DRILL
 3 STEPS
 List \$2.51



PART #
277PD0016
 1/4" HSS PILOT DRILL
 3 FLATS
 List \$2.51



PART #
277PD0018
 1/4" HSS PILOT DRILL
 1 FLAT
 List \$2.75



PART #
277PD0020
 1/4" CARBIDE PILOT DRILL
 2-7/8" LONG 1 FLAT
 List \$6.57



PART #
277PD0022
 1/4" CARBIDE PILOT DRILL
 4" LONG 1 FLAT
 List \$6.89

- ◆ Industrial Quality.
- ◆ High Speed Steel.
- ◆ Designed For Arbors.
- ◆ HSS Sold 10/ Pack.
- ◆ Carbide Sold Individually.

Arbor Adapter Nut

PART #
NUT001



Adapter Nut

Turns
 1/2"-20
 Thread
 to 5/8"-18

List
 \$6.65

Adapter nut allows smaller arbors without pins to fit larger hole saws. Not recommended for use with hole saws larger than 2-1/2".

Will work with any of the following 1/2"-20 threaded arbors:

- 276AR0001
- 276AR0002
- 276AR0025
- 276CT0034

Extension

PART #
EXT001

12" Arbor
 Extension

For 7/16" Hex
 Shank Arbors
 Only!!!

List
 \$23.15



Arbors - With Pilot Drills

Made In



- ◆ Made In U.S.A.
- ◆ High Quality.
- ◆ Sold Individually in White Boxes.
- ◆ Includes one 3-Flats HSS Pilot Drill.

FOR USE WITH:

- Bi-Metal Hole Saws
- Carbide Hole Saws
- Carbide Grit Hole Saws



Use Arbors with Carbide Tipped Pilots when drilling with Carbide Tipped Hole Saws & Carbide Grit Hole Saws in:

- Particle Board
- Formica
- Tile
- Ceramics
- Fiberglass
- Granite
- Marble

PART #
276AR001
 1/4" ROUND SHANK
 ARBOR FOR HOLE SAWS
 9/16" - 1-3/16"
 List \$11.14



1/2"-20 Thread

PART #
276AR002
 7/16" HEX SHANK
 ARBOR FOR HOLE SAWS
 9/16" - 1-3/16"
 List \$15.48



1/2"-20 Thread

PART #
276AR0025
 1/4" HEX POWER SHANK
 ARBOR FOR HOLE SAWS
 9/16" - 1-3/16"
 List \$12.50



1/2"-20 Thread
 HSS PILOT
 277PD0018

PART #
276AR0003
 7/16" HEX SHANK
 ARBOR FOR HOLE SAWS
 1 1/4" - 6"
 List \$24.50



5/8"-18 Thread

PART #
276AR0035
 3/8" HEX SHANK
 FOR HOLE SAWS
 1 1/4" - 6"
 List \$24.50



5/8"-18 Thread
 HSS PILOT
 277PD0018

PART #
276CT0034
 3/8" HEX SHANK
 FOR HOLE SAWS
 3/4" - 1-3/16"
 List \$15.95



1/2"-20 Thread
 CARBIDE PILOT
 277PD0020

PART #
276CT0045
 7/16" HEX SHANK
 FOR HOLE SAWS
 1 1/4" - 6"
 List \$26.50



5/8"-18 Thread
 CARBIDE PILOT
 277PD0022

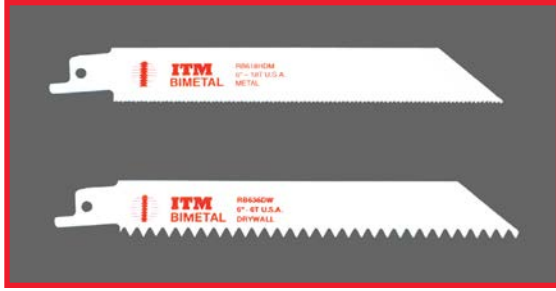

- ◆ Made In **U.S.A.**
- ◆ 1/2" Universal Shank
- ◆ Milled Teeth
- ◆ Matrix II Cutting Edge
- ◆ Tooth Hardness Rc 65-67
- ◆ 8% Cobalt
- ◆ Vacuum Heat Treatment
- ◆ Long Life
- ◆ Shock Resistant Teeth
- ◆ High Edge Hardness
- ◆ High Heat Resistance
- ◆ High Wear Resistance
- ◆ Greater Rigidity
- ◆ Resists Tooth Strippage
- ◆ Accepts Higher Feed Pressure.

Made In



All Purpose Reciprocating Blades - Bi-Metal

Part #	Blade Length	Teeth Per Inch	Description	Width / Length	Pack QTY.	List	Bulk (50 Pcs.) Part #	List
RB636W	6"	6T	Wood & Nail Slope	3/4" x 6" x .050	5	\$3.06	BU-RB636W	\$3.01
RB656WS	6"	6T	Wood & Nail Scroll	3/4" x 6" x .050	5	\$3.17	BU-RB656WS	\$3.12
RB956W	9"	6T	Wood & Nail	3/4" x 9" x .050	5	\$4.31	BU-RB956W	\$4.06
RB125W	12"	6T	Wood & Nail	3/4" x 12" x .050	5	\$5.41	BU-RB125W	\$5.36
RB414M	4"	14T	Metal	3/4" x 4" x .035	5	\$1.89	BU-RB414M	\$1.81
RB418M	4"	18T	Metal	3/4" x 4" x .035	5	\$1.89	BU-RB418M	\$1.81
RB424M	4"	24T	Metal	3/4" x 4" x .035	5	\$1.89	BU-RB424M	\$1.81
RB610HDM	6"	10T	Metal	3/4" x 6" x .035	5	\$2.36	BU-RB610HDM	\$2.28
RB614HDM	6"	14T	Metal	3/4" x 6" x .035	5	\$2.36	BU-RB614HDM	\$2.28
RB618HDM	6"	18T	Metal	3/4" x 6" x .035	5	\$2.36	BU-RB618HDM	\$2.28
RB624HDM	6"	24T	Metal	3/4" x 6" x .035	5	\$2.36	BU-RB624HDM	\$2.28
RB810HDM	8"	10T	Metal 10/14 V.P.	3/4" x 8" x .035	5	\$3.67	BU-RB810HDM	\$3.52
RB814HDM	8"	14T	Metal	3/4" x 8" x .035	5	\$3.67	BU-RB814HDM	\$3.52
RB818HDM	8"	18T	Metal	3/4" x 8" x .035	5	\$3.67	BU-RB818HDM	\$3.52
RB1010HDM	10"	10T	Metal	3/4" x 10" x .035	5	\$5.35	BU-RB1010HDM	\$5.25
RB1018HDM	10"	18T	Metal	3/4" x 10" x .035	5	\$5.35	BU-RB1018HDM	\$5.25
RB1218HDM	12"	18T	Metal	3/4" x 12" x .035	5	\$5.55	BU-RB1218HDM	\$5.45
RB636DW	6"	6T	Drywall V Head	3/4" x 6" x .035	5	\$2.53	BU-RB636DW	\$2.44
R8CCRF	8"	Carbide Grit	Cast Iron-Ceramic Tile	3/4" x 8" x .050	1	\$9.03	BU-R8CCRF	\$8.89

MAIN OFFICE
 INTERNATIONAL TOOL MANUFACTURING
 71-08 51ST. AVENUE, WOODSIDE, NY 11377
 (718) 446-0711 - (800) 247-5696 - FAX (718) 899-6553



INTERNATIONAL TOOL MANUFACTURING
 675-E-PROGRESS CENTER AVE., LAWRENCEVILLE, GA 30043
 (770) 962-5454 - (800) 229-1776 - FAX (770) 962-5869

VIGOR™

Industrial Blades are Vigorous Blades.

- ◆ Made In U.S.A.
- ◆ 1/2" Universal Shank
- ◆ 45% Thicker Than All Purpose Blades
- ◆ Wider Than All Purpose Blades
- ◆ Stay Rigid
- ◆ No Vibration
- ◆ More Cuts Per Blade

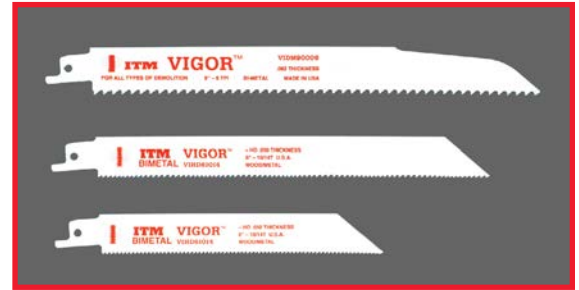

Made In



VIGOR Heavy Duty Reciprocating Blades - Bi-Metal

Part #	Blade Length	Teeth Per Inch	Description	Width / Length	Pack QTY.	List	Bulk (50 Pcs.) Part #	List
VIHD61014	6"	10/14 V.P.	HEAVY DUTY	3/4" X 6" X .050	5	\$3.20	BU-VIHD61014	\$3.05
VIHD81014	8"	10/14 V.P.	HEAVY DUTY	3/4" X 8" X .050	5	\$4.38	BU-VIHD81014	\$4.18
VIHD12014	12"	10/14 V.P.	HEAVY DUTY	3/4" X 12" X .050	5	\$5.45	BU-VIHD12014	\$5.35

V.P. = Variable Pitch (Teeth)



VIGOR Demolition Reciprocating Blades - Bi-Metal

Part #	Blade Length	Teeth Per Inch	Description	Width / Length	Pack QTY.	List	Bulk (25 Pcs.) Part #	List
VIDM60006	6"	6T	DEMOLITION	7/8" X 6" X .062	3	\$5.83	BU-VIDM60006	\$5.76
VIDM60010	6"	10T	DEMOLITION	7/8" X 6" X .062	3	\$5.83	BU-VIDM60010	\$5.76
VIDM90006	9"	6T	DEMOLITION	7/8" X 9" X .062	3	\$8.15	BU-VIDM90006	\$7.75
VIDM90010	9"	10T	DEMOLITION	7/8" X 9" X .062	3	\$8.15	BU-VIDM90010	\$7.75
VIDM12006	12"	6T	DEMOLITION	7/8" X 12" X .062	3	\$9.84	BU-VIDM12006	\$9.35
VIHD12010	12"	10T	DEMOLITION	7/8" X 12" X .062	3	\$9.84	BU-VIHD12010	\$9.35

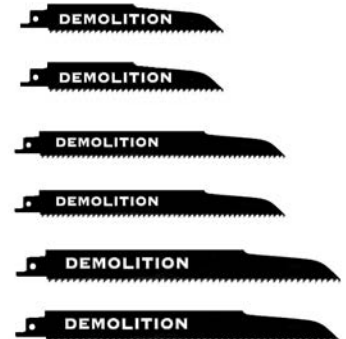

Tooth Style:



Standard beveled configuration



10/14 Variable Pitch beveled configuration









Made In







- ◆ Made In U.S.A.
- ◆ Industrial Quality
- ◆ Milled Teeth





BOSCH Shank Metal Cutting Blades - Bi-Metal

Part #	Blade Length	Teeth Per Inch	Description	Width / Length	Application	Pack QTY.	List	Bulk (50 Pcs.) Part #	List
 BJB30014M	3"	14T	BOSCH SHANK JIG SAW	3" x 3/8" x 0.35	THICK METAL	5	\$2.45	BJB30014MB	\$2.21
 BJB30018M	3"	18T	BOSCH SHANK JIG SAW	3" x 3/8" x 0.35	METAL TUBING	5	\$2.45	BJB30018MB	\$2.21
 BJB30024M	3"	24T	BOSCH SHANK JIG SAW	3" x 3/8" x 0.35	THIN METAL TUBING	5	\$2.45	BJB30024MB	\$2.21
 BJB52521M	5-1/4"	21T	BOSCH SHANK JIG SAW	5-1/4" x 5/16" x .042	SOFT STEEL ALUMINUM	5	\$5.10	BJB52521MB	\$4.59



BOSCH Shank Wood / Plastic Cutting Blades - Bi-Metal

Part #	Blade Length	Teeth Per Inch	Description	Width / Length	Application	Pack QTY.	List	Bulk (50 Pcs.) Part #	List
 BJB40006W	4"	6T	BOSCH SHANK JIG SAW	4" x 5/16" x .040	WOOD FIBER BOARD	5	\$3.01	BJB40006WB	\$2.71
 BJB40008W	4"	8T	BOSCH SHANK JIG SAW	4" x 5/16" x .035	GENERAL WOOD/PLASTIC	5	\$3.01	BJB40008WB	\$2.71
 BJB40010W	4"	10T	BOSCH SHANK JIG SAW	4" x 5/16" x .035	ALL WOOD/PLASTIC	5	\$3.01	BJB40010WB	\$2.71
 BJB52512W	5-1/4"	12T	BOSCH SHANK JIG SAW	5-1/4" x 5/16" x .042	WOOD/PLASTIC METAL	5	\$5.10	BJB52512WB	\$4.59

UNIVERSAL Shank Metal Cutting Blades - Bi-Metal

Part #	Blade Length	Teeth Per Inch	Description	Width / Length	Application	Pack QTY.	List	Bulk (50 Pcs.) Part #	List
 UJB23418M	2-3/4"	18T	UNIVERSAL SHANK JIG SAW BLADE	2-3/4" x 3/16" x .035	SCROLL METAL	5	\$2.03	UJB23418MB	\$1.83
 UJB30018M	3"	18T	UNIVERSAL SHANK JIG SAW BLADE	3" x 3/8" x .035	METAL 18 GAUGE & UNDER	5	\$2.03	UJB30018MB	\$1.83
 UJB30024M	3"	24T	UNIVERSAL SHANK JIG SAW BLADE	3" x 3/8" x .035	METAL 18 GAUGE & UNDER	5	\$2.03	UJB30024MB	\$1.83
 UJB40014M	4"	14T	UNIVERSAL SHANK JIG SAW BLADE	4" x 3/8" x .035	WOOD, RUBBER METAL UP TO 1/8"	5	\$2.30	UJB40014MB	\$2.07

UNIVERSAL Shank Wood Cutting Blades - Bi-Metal

Part #	Blade Length	Teeth Per Inch	Description	Width / Length	Application	Pack QTY.	List	Bulk (50 Pcs.) Part #	List
 UJB40006W	4"	6T	UNIVERSAL SHANK JIG SAW BLADE	4" x 3/8" x .035	HARD WOOD BOARD	5	\$2.30	UJB40006WB	\$2.07
 UJB40010W	4"	10T	UNIVERSAL SHANK JIG SAW BLADE	4" x 3/8" x .035	HARD WOOD BOARD	5	\$2.30	UJB40010WB	\$2.07



5/pk Retail Pack

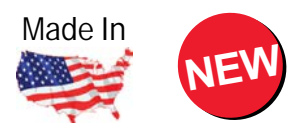

All Purpose Reciprocating Blades - Bi-Metal

Part #	Blade Length	Teeth Per Inch	Pack Description	Width / Length	QTY.	List
W636	6"	6T	WOOD & NAIL SLOPE	3/4" x 6" x .050	5	\$15.56
W956	9"	6T	WOOD & NAIL	3/4" x 9" x .050	5	\$22.92
W125	12"	6T	WOOD & NAIL	3/4" x 12" x .050	5	\$28.47
M614	6"	14T	METAL	3/4" x 6" x .035	5	\$12.78
M618	6"	18T	METAL	3/4" x 6" x .035	5	\$12.78
M624	6"	24T	METAL	3/4" x 6" x .035	5	\$12.78
M810	8"	10T	METAL	3/4" x 8" x .035	5	\$18.75
M814	8"	14T	METAL	3/4" x 8" x .035	5	\$18.75
M818	8"	18T	METAL	3/4" x 8" x .035	5	\$18.75
M1218	12"	18T	METAL	3/4" x 12" x .035	5	\$29.17



Now with On-Blade Barcode.

- ◆ Made In USA
- ◆ Same Bi-Metal Blades P. 66
- ◆ Slim-Line Retail Packs
- ◆ Price Per Pack



50/pk Retail Pack

All Purpose Reciprocating Blades - Bi-Metal

Part #	Blade Length	Teeth Per Inch	Pack Description	Width / Length	QTY.	List
W636-B	6"	6T	WOOD & NAIL SLOPE	3/4" x 6" x .050	50	\$153.00
W956-B	9"	6T	WOOD & NAIL	3/4" x 9" x .050	50	\$220.50
W125-B	12"	6T	WOOD & NAIL	3/4" x 12" x .050	50	\$274.50
M614-B	6"	14T	METAL	3/4" x 6" x .035	50	\$118.50
M618-B	6"	18T	METAL	3/4" x 6" x .035	50	\$118.50
M624-B	6"	24T	METAL	3/4" x 6" x .035	50	\$118.50
M810-B	8"	10T	METAL	3/4" x 8" x .035	50	\$181.00
M814-B	8"	14T	METAL	3/4" x 8" x .035	50	\$181.00
M818-B	8"	18T	METAL	3/4" x 8" x .035	50	\$181.00
M1218-B	12"	18T	METAL	3/4" x 12" x .035	50	\$278.00



- ◆ RED Cast Aluminum
- ◆ Light Weight
- ◆ Extremely Rigid
- ◆ Versatile
- ◆ 25,000 lbs Per Square Inch
- ◆ Includes 1 12" x 24T Bi-Metal Blade

This High Tension Hack Saw Frame features a **NEW Cushin' Grip** handle and end pieces made of die cast aluminum. It is light weight yet extremely rigid and high tensioned; which provides cleaner, surer cuts. The blade can be set at a 55° angle for special flush cutting jobs (see figure **A**). The blade can also be inserted into the front end of the hack saw frame, and used as a versatile compass saw (see figure **B**). This frame fits most standard tool boxes.

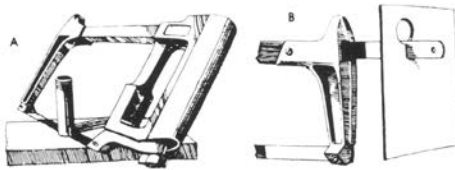

High Tension Hack Saw Frame

Part #	Description	List
278HX0002	High Tension Hack Saw Frame	\$24.97



Made In



- ◆ Made In USA
- ◆ Bi-Metal
- ◆ Premium Quality
- ◆ White Finish

Hack Saw Blades - Bi-Metal

Part #	OAL	Teeth Per Inch	Wide	Thick	QTY.	List
278BM0018	12"	18T	1/2"	.025	10	\$1.80
278BM0024	12"	24T	1/2"	.025	10	\$1.80
278BM0032	12"	32T	1/2"	.025	10	\$1.80

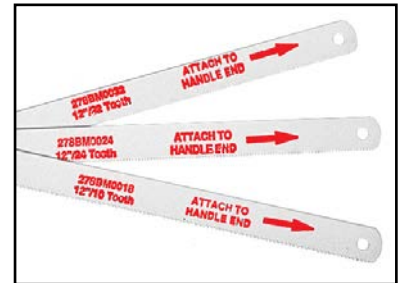

Made In



- ◆ Made In USA
- ◆ Bi-Metal
- ◆ Premium Quality
- ◆ Standard or Variable Pitch
- ◆ White Finish
- ◆ Use In All Hand Held Band Saws



Band Saw Blades - Bi-Metal

Part #	OAL	Teeth Per Inch	Wide	Thick	QTY.	List
279SB0010	44-7/8"	10T	1/2"	.020	3	\$10.92
279SB0014	44-7/8"	14T	1/2"	.020	3	\$10.92
279SB0018	44-7/8"	18T	1/2"	.020	3	\$10.92
279SB0024	44-7/8"	24T	1/2"	.020	3	\$10.92
279VP1014	44-7/8"	10/14	1/2"	.020	3	\$10.92
279VP1418	44-7/8"	14/18	1/2"	.020	3	\$10.92

MAIN OFFICE
 INTERNATIONAL TOOL MANUFACTURING
 71-08 51ST. AVENUE, WOODSIDE, NY 11377
 (718) 446-0711 - (800) 247-5696 - FAX (718) 899-6553



INTERNATIONAL TOOL MANUFACTURING
 675-E-PROGRESS CENTER AVE., LAWRENCEVILLE, GA 30043
 (770) 962-5454 - (800) 229-1776 - FAX (770) 962-5869



RACK12
 7"Out X 8"H X 24"W

- ◆ 1/4" Metal Wire
- ◆ Heavy Duty
- ◆ Black Oxide Finish

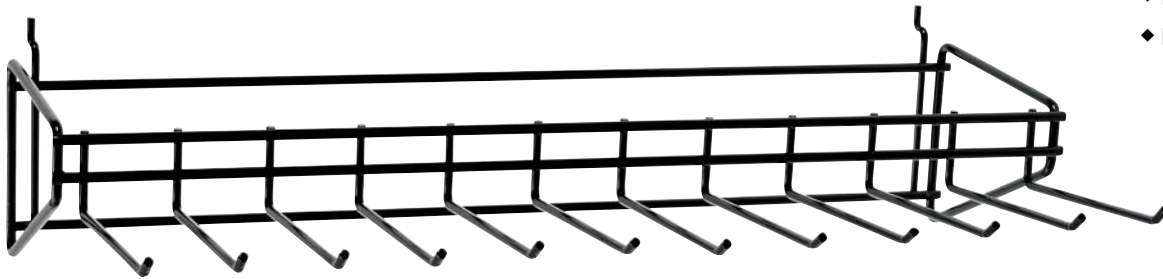

RACK18
 15"Out X 8"H X 24"W

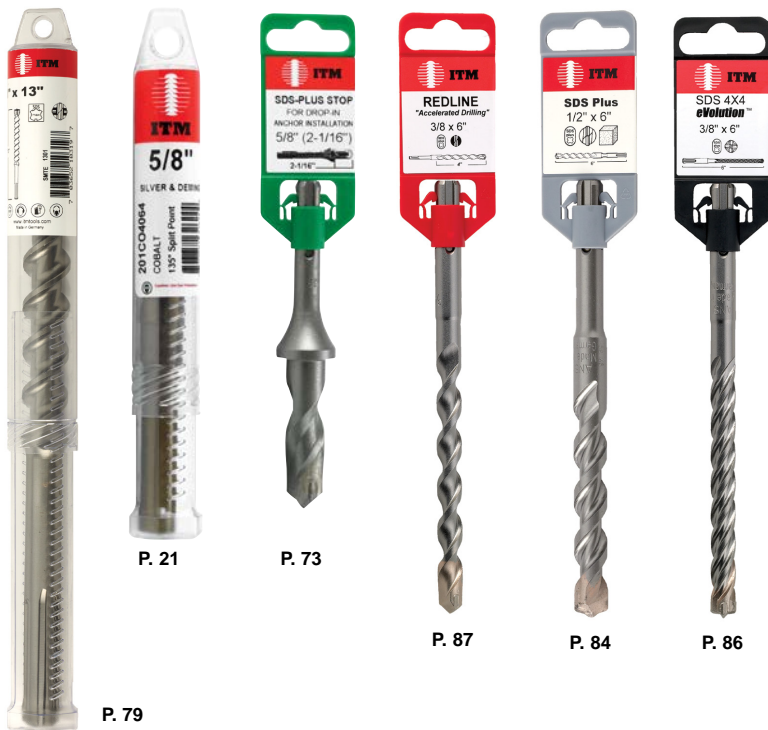

Metal Rack

Part #	Rack	List
RACK12	Top Header	\$59.10
RACK18	Bottom X-Tra	\$68.99

All individually packed ITM drill bits have barcode and can be hung on this display. Simple and hassle free.



- ◆ Multi Purpose
- ◆ Tungsten Carbide
- ◆ Turbo Flute
- ◆ Heat Treated Body
- ◆ Polished Finish
- ◆ High Wearability
- ◆ Straight Shank
- ◆ ANSI Specification

- Brick
- Cement
- Tile
- Marble
- Fiberglass
- Metal
- Wood



Multi Purpose Drills - CARBIDE TIP

Part #	Size	O/A	Drilling	Shank	List
600CD0864	1/8"	3"	1-1/2"	1/8"	\$4.96
600CD1064	5/32"	3-1/8"	1-3/4"	5/32"	\$5.35
600CD1264	3/16"	3-1/2"	2-3/16"	3/16"	\$5.49
600CD1664	1/4"	4-1/8"	2-9/16"	1/4"	\$6.03
600CD2064	5/16"	4-3/4"	3-5/32"	5/16"	\$8.18
600CD2464	3/8"	6"	4-3/8"	3/8"	\$11.32
600CD3264	1/2"	6-3/4"	4"	1/2"	\$13.27
600CD4064	5/8"	6"	4"	1/2"	\$16.16

"THE PERFECT CARBIDE BIT FOR ANY FASTENING OR RENOVATION JOB!!!"

This drill bit is specially developed for efficient *rotary* drilling in a wide range of materials in one operation without changing the drill bit. Ideal for cordless machines and any fastening jobs where drilling in different materials is necessary.

ROTATION ONLY



Glass Drills - CARBIDE TIP

Part #	Size	O/A	Shank	List
601GL0864	1/8"	2-1/4"	1/8"	\$7.41
601GL1264	3/16"	2-3/4"	3/16"	\$8.54
601GL1664	1/4"	3"	1/4"	\$9.05
601GL2064	5/16"	3-1/4"	1/4"	\$10.05
601GL2464	3/8"	3-1/2"	3/8"	\$14.13
601GL3264	1/2"	4"	3/8"	\$20.10

- ◆ Spear Point
- ◆ Tungsten Carbide Tip

- Glass
- Mirrors
- Ceramic
- Tile

ROTATION ONLY

Slow drilling speeds and lubricant are recommended when using these drills.



- ◆ Carbide Tip
- ◆ Tempered Body
- ◆ ANSI B212.15-1994

Hard Steel Drill - Right Hand

Part #	Size	X	OAL	Shank	List
RHB-18	1/8"	X	2-3/4"	1/8"	\$9.21
RHB-20	3/16"	X	3"	3/16"	\$10.29
RHB-22	1/4"	X	4"	1/4"	\$11.67
RHB-24	1/4"	X	6"	1/4"	\$12.25
RHB-26	5/16"	X	4"	1/4"	\$12.71
RHB-28	5/16"	X	6"	5/16"	\$13.38
RHB-30	3/8"	X	4"	1/4"	\$13.25
RHB-32	3/8"	X	6"	3/8"	\$14.08

- Broken Bolts
- Freeze Plugs
- Bearing Races
- Safes
- Shafts
- Gears
- Industrial Parts

Hard Steel Drill - Left Hand

Part #	Size	X	OAL	Shank	List
LHB-18	1/8"	X	2-3/4"	1/8"	\$11.63
LHB-20	3/16"	X	3"	3/16"	\$12.54
LHB-22	1/4"	X	4"	1/4"	\$13.92
LHB-24	1/4"	X	6"	1/4"	\$14.50
LHB-26	5/16"	X	4"	1/4"	\$15.08
LHB-28	5/16"	X	6"	5/16"	\$15.63
LHB-30	3/8"	X	4"	1/4"	\$15.88
LHB-32	3/8"	X	6"	3/8"	\$17.92

MAIN OFFICE
INTERNATIONAL TOOL MANUFACTURING
71-08 51ST. AVENUE, WOODSIDE, NY 11377
(718) 446-0711 - (800) 247-5696 - FAX (718) 899-6553



INTERNATIONAL TOOL MANUFACTURING
675-E-PROGRESS CENTER AVE., LAWRENCEVILLE, GA 30043
(770) 962-5454 - (800) 229-1776 - FAX (770) 962-5869



Made In



V-GROOVE

Part #	Size	X	O/A	SHANK	Qty.	List
GRT-4001	1/8"	X	3"	1/8"	1	\$5.75
GRT-4002	3/16"	X	4"	3/16"	1	\$7.17
GRT-6001	3/16"	X	6"	3/16"	1	\$7.58
GRT-4003	1/4"	X	4"	1/4"	1	\$7.17
GRT-6002	1/4"	X	6"	1/4"	1	\$7.58
GRT-6003	5/16"	X	6"	5/16"	1	\$12.60
GRT-6004	3/8"	X	6"	3/8"	1	\$15.45
GRT-6005	1/2"	X	6"	1/2"	1	\$21.83

- ◆ Precision Design
- ◆ V-Groove Carbide Head

- Marble
- Tile
- Porcelain



For Drop-in Anchors

Made In



SDS+ STOP

Part #	Size	Drill Depth	Qty.	List
STP-413	1/4"	11/16"	1	\$24.10
STP-611	3/8"	11/16"	1	\$24.26
STP-617	3/8"	1-1/16"	1	\$24.75
STP-813	1/2"	13/16"	1	\$25.07
STP-827	1/2"	1-11/16"	1	\$26.96
STP-1019	5/8"	1-3/16"	1	\$30.83
STP-1033	5/8"	2-1/16"	1	\$31.59



- ◆ STOP - Lip Prevents Over-Drilling
- ◆ Drill Exact Depth For Drop-In Anchor
- ◆ Less Likely to Hit Rebar



ANSI



Sold BULK only

Fast Spiral Masonry Drills

Part #	Size	X	O/A	Shank	List
500BU0632	3/16"	X	4"	3/16"	\$1.24
500BU0832	1/4"	X	4"	1/4"	\$1.36
500BU1032	5/16"	X	4"	1/4"	\$1.70
500BU1232	3/8"	X	4"	1/4"	\$2.26
500BU1632	1/2"	X	4"	1/4"	\$3.39
500BU6832	1/4"	X	6"	1/4"	\$2.50
500BU7032	5/16"	X	6"	1/4"	\$2.99
500BU8032	3/8"	X	6"	3/8"	\$3.39
500BU9032	1/2"	X	6"	3/8"	\$3.64

Slow Spiral Masonry Drills

Part #	Size	X	O/A	Shank	List
501BU0632	3/16"	X	4"	3/16"	\$1.24
501BU0832	1/4"	X	4"	1/4"	\$1.36
501BU1032	5/16"	X	4"	1/4"	\$1.70
501BU1232	3/8"	X	4"	1/4"	\$2.26
501BU1632	1/2"	X	4"	1/4"	\$3.39
501BU6832	1/4"	X	6"	1/4"	\$2.50
501BU7032	5/16"	X	6"	1/4"	\$2.99
501BU8032	3/8"	X	6"	3/8"	\$3.39
501BU9032	1/2"	X	6"	3/8"	\$3.64

- ◆ General Purpose
- ◆ Tungsten Carbide
- ◆ Tempered Body
- ◆ Nickel Plated Finish
- ◆ Straight Shank
- ◆ ANSI Specification

- Brick
- Cement
- Clay Pipe
- Tile
- Slate
- Cinder Block



ANSI



Slow Spiral Masonry Drills

Pouched **Black Oxide**

Part #	Size	X	O/A	Shank	List
502SP4001	1/8"	X	3"	1/8"	\$1.35
502SP4002	3/16"	X	4"	3/16"	\$1.48
502SP6001	3/16"	X	6"	3/16"	\$2.66
502SP4732	7/32"	X	4"	7/32"	\$1.58
502SP4003	1/4"	X	4"	1/4"	\$1.61
502SP6002	1/4"	X	6"	1/4"	\$2.84
502SP1201	1/4"	X	12"	1/4"	\$6.26
502SP1814	1/4"	X	18"	1/4"	\$8.33
502SP4004	5/16"	X	4"	1/4"	\$1.98
502SP6003	5/16"	X	6"	1/4"	\$3.39
502SP1202	5/16"	X	12"	1/4"	\$7.10
502SP1856	5/16"	X	18"	5/16"	\$9.35
502SP4005	3/8"	X	4"	1/4"	\$2.65
502SP6004	3/8"	X	6"	3/8"	\$3.83
502SP1203	3/8"	X	12"	3/8"	\$8.41
502SP1838	3/8"	X	18"	3/8"	\$10.95
502SP2438	3/8"	X	24"	3/8"	\$14.65
502SP6005	7/16"	X	6"	1/4"	\$3.95
502SP4006	1/2"	X	4"	1/4"	\$3.95
502SP6006	1/2"	X	6"	1/4"	\$4.08
502SP6007	1/2"	X	6"	3/8"	\$4.08
502SP1204	1/2"	X	12"	3/8"	\$9.43
502SP1812	1/2"	X	18"	3/8"	\$12.21
502SP6008	9/16"	X	6"	3/8"	\$6.55
502SP6009	5/8"	X	6"	3/8"	\$7.19
502SP1205	5/8"	X	12"	3/8"	\$13.33
502SP1858	5/8"	X	18"	3/8"	\$16.99
502SP6010	3/4"	X	6"	1/2"	\$9.34
502SP1206	3/4"	X	12"	1/2"	\$16.85
502SP1834	3/4"	X	18"	1/2"	\$21.71
502SP6011	7/8"	X	6"	1/2"	\$10.92
502SP1207	7/8"	X	12"	1/2"	\$18.94
502SP1878	7/8"	X	18"	1/2"	\$23.87
502SP6012	1"	X	6"	1/2"	\$14.47
502SP1208	1"	X	12"	1/2"	\$21.35
502SP1801	1"	X	18"	1/2"	\$28.69

Slow Spiral Masonry Drills

BULK **Black Oxide**

Part #	Size	X	O/A	Shank	List
502BU4001	1/8"	X	3"	1/8"	\$1.24
502BU4002	3/16"	X	4"	3/16"	\$1.35
502BU6001	3/16"	X	6"	3/16"	\$2.47
502BU4732	7/32"	X	4"	7/32"	\$1.50
502BU4003	1/4"	X	4"	1/4"	\$1.46
502BU6002	1/4"	X	6"	1/4"	\$2.59
502BU1201	1/4"	X	12"	1/4"	\$5.70
502BU1814	1/4"	X	18"	1/4"	\$7.70
502BU4004	5/16"	X	4"	1/4"	\$1.78
502BU6003	5/16"	X	6"	1/4"	\$3.10
502BU1202	5/16"	X	12"	1/4"	\$6.47
502BU1856	5/16"	X	18"	5/16"	\$8.71
502BU4005	3/8"	X	4"	1/4"	\$2.42
502BU6004	3/8"	X	6"	3/8"	\$3.49
502BU1203	3/8"	X	12"	3/8"	\$7.64
502BU1838	3/8"	X	18"	3/8"	\$10.31
502BU2438	3/8"	X	24"	3/8"	\$12.65
502BU6005	7/16"	X	6"	1/4"	\$3.59
502BU4006	1/2"	X	4"	1/4"	\$6.52
502BU6006	1/2"	X	6"	1/4"	\$3.71
502BU6007	1/2"	X	6"	3/8"	\$3.71
502BU1204	1/2"	X	12"	3/8"	\$8.59
502BU1812	1/2"	X	18"	3/8"	\$11.58
502BU6008	9/16"	X	6"	3/8"	\$5.96
502BU6009	5/8"	X	6"	3/8"	\$6.63
502BU1205	5/8"	X	12"	3/8"	\$12.13
502BU1858	5/8"	X	18"	3/8"	\$16.36
502BU6010	3/4"	X	6"	1/2"	\$8.49
502BU1206	3/4"	X	12"	1/2"	\$15.61
502BU1834	3/4"	X	18"	1/2"	\$21.07
502BU6011	7/8"	X	6"	1/2"	\$9.93
502BU1207	7/8"	X	12"	1/2"	\$17.21
502BU1878	7/8"	X	18"	1/2"	\$23.24
502BU6012	1"	X	6"	1/2"	\$13.26
502BU1208	1"	X	12"	1/2"	\$20.22
502BU1801	1"	X	18"	1/2"	\$28.06

- ◆ General Purpose
- ◆ Tungsten Carbide
- ◆ Slow Spiral Flute
- ◆ Tempered Body
- ◆ Black Oxide Finish
- ◆ Gold Head
- ◆ Straight Shank
- ◆ ANSI Specification

- Brick
- Cement
- Clay Pipe
- Tile
- Slate
- Cinder Block



Use with rotation or Percussion

A first generation carbide tipped drill bit, mass produced since the early 1970's, first in Europe, then in Puerto Rico, then in the USA. Still used ubiquitously and found in anchor kits all over the world.



ANSI

MAIN OFFICE
 INTERNATIONAL TOOL MANUFACTURING
 71-08 51ST. AVENUE, WOODSIDE, NY 11377
 (718) 446-0711 - (800) 247-5696 - FAX (718) 899-6553



INTERNATIONAL TOOL MANUFACTURING
 675-E-PROGRESS CENTER AVE., LAWRENCEVILLE, GA 30043
 (770) 962-5454 - (800) 229-1776 - FAX (770) 962-5869



Roto Percussion Drills - Super Shlager

Part #	Size	X	O/A	Drilling	Shank	List
700040864	1/8"	X	3"	1-1/2"	1/8"	\$3.16
700061064	5/32"	X	6"	4"	5/32"	\$4.03
700041264	3/16"	X	3-1/2"	1-3/4"	3/16"	\$3.35
700061264	3/16"	X	6"	4"	3/16"	\$3.89
700041664	1/4"	X	4"	2-1/2"	1/4"	\$3.35
700061664	1/4"	X	6"	4"	1/4"	\$4.42
700081664	1/4"	X	12"	10"	1/4"	\$9.19
700024166	1/4"	X	24"	20"	1/4"	\$18.23
700041864	9/32"	X	4"	2-1/2"	1/4"	\$3.99
700042064	5/16"	X	4-3/4"	3-1/2"	5/16"	\$4.18
700062064	5/16"	X	6"	4"	5/16"	\$5.74
700061464	7/32"	X	6"	4"	7/32"	\$4.62
700062464	3/8"	X	6"	4"	3/8"	\$5.74
700082464	3/8"	X	12"	10"	3/8"	\$10.60
700020246	3/8"	X	20"	16"	3/8"	\$16.63
700024246	3/8"	X	24"	20"	3/8"	\$20.66
700062864	7/16"	X	6"	4"	3/8"	\$8.56
700063264	1/2"	X	6"	4"	3/8"	\$8.26
700083264	1/2"	X	12"	10"	3/8"	\$15.46
700020326	1/2"	X	20"	16"	3/8"	\$19.88
700024326	1/2"	X	24"	20"	3/8"	\$23.82
700063664	9/16"	X	6"	4"	Hex 3/8"	\$11.91
700064064	5/8"	X	6"	4"	Hex 3/8"	\$12.49
700084064	5/8"	X	12"	10"	Hex 3/8"	\$19.69
700024406	5/8"	X	24"	20"	Hex 1/2"	\$26.78
700064864	3/4"	X	6"	4"	Hex 1/2"	\$15.90
700084864	3/4"	X	12"	10"	Hex 1/2"	\$22.65
700065664	7/8"	X	6"	4"	Hex 1/2"	\$18.91
700085664	7/8"	X	12"	10"	Hex 1/2"	\$31.06
700066464	1"	X	6"	4"	Hex 1/2"	\$22.36
700086464	1"	X	12"	10"	Hex 1/2"	\$35.78
700024646	1"	X	24"	20"	Hex 1/2"	\$62.71

- ◆ Heavy Duty
- ◆ Percussion Grade Tungsten Carbide
- ◆ Unique Spiral Flute for Fast Dust Removal
- ◆ Heat Treated Body
- ◆ Polished Finish
- ◆ Hex Shank on Larger Diameters to Prevent Slipping
- ◆ ANSI Specification

- Concrete
- Cement
- Stone
- Granite
- Cinder Block



BARCODED

SOLD INDIVIDUALLY.
 1 PER TUBE.



These Drill Bits are made for machines with percussion. They will not perform with rotation only.



Spline Drive - Bohr Hammer

- ◆ Industrial Quality
- ◆ Special Tungsten Carbide Tip
- ◆ Copper / Silver Brazing
- ◆ Fastest Dust Removal
- ◆ Fastest Drilling Speeds
- ◆ Heat Treated Body
- ◆ Clean Round Holes
- ◆ Less Vibration
- ◆ Polished Finish
- ◆ ANSI Specification

- Brick
- Stone
- Masonry
- Aggregates



BARCODED

SOLD INDIVIDUALLY.
 1 PER TUBE.



Part #	Size	X	O/A	Drilling	Head	List
717SP1238	3/8"	X	10"	5"	REGULAR	\$37.80
717SP1238	3/8"	X	16"	11"	REGULAR	\$49.19
717SP1212	1/2"	X	10"	5"	REGULAR	\$39.84
717SP1612	1/2"	X	16"	11"	REGULAR	\$46.47
717SP2212	1/2"	X	22"	17"	REGULAR	\$60.39
717SP2812	1/2"	X	29"	24"	REGULAR	\$81.38
717SP3612	1/2"	X	36"	31"	REGULAR	\$111.08
717SP1291	9/16"	X	10"	5"	REGULAR	\$52.96
717SP1691	9/16"	X	16"	11"	REGULAR	\$66.91
717SP2291	9/16"	X	23"	17"	REGULAR	\$70.27
717SP2891	9/16"	X	29"	24"	REGULAR	\$107.98
717SP1258	5/8"	X	10"	5"	REGULAR	\$56.32
717SP1658	5/8"	X	16"	11"	REGULAR	\$69.75
717SP2258	5/8"	X	22"	17"	REGULAR	\$77.50
717SP3658	5/8"	X	36"	31"	REGULAR	\$143.47
717SP1211	11/16"	X	13"	8"	REGULAR	\$66.39
717SP1611	11/16"	X	16"	11"	REGULAR	\$78.79
717SP1234	3/4"	X	10"	5"	REGULAR	\$58.38
717SP1634	3/4"	X	16"	11"	REGULAR	\$65.88
717SP2234	3/4"	X	22"	17"	REGULAR	\$78.02
717SP3634	3/4"	X	36"	31"	REGULAR	\$151.39
717SP1678	7/8"	X	16"	11"	REGULAR	\$73.63
717SP3678	7/8"	X	22"	17"	REGULAR	\$85.28
717SP2278	7/8"	X	36"	31"	REGULAR	\$159.56
717SP1201	1"	X	13"	8"	REGULAR	\$76.21
717SP1601	1"	X	16"	11"	REGULAR	\$82.41
717SP2201	1"	X	22"	17"	REGULAR	\$96.88
717SP3601	1"	X	36"	31"	REGULAR	\$169.17
717SP1618	1-1/8"	X	16"	11"	REGULAR	\$79.40
717SP2218	1-1/8"	X	22"	17"	REGULAR	\$128.65
717SP1614	1-1/4"	X	16"	11"	REGULAR	\$109.02
717SP2214	1-1/4"	X	22"	17"	REGULAR	\$128.65
717SP3614	1-1/4"	X	36"	31"	REGULAR	\$189.34
717SP2213	1-3/8"	X	22"	17"	REGULAR	\$180.32
717SP6112	1-1/2"	X	16"	11"	REGULAR	\$149.32
717SP4112	1-1/2"	X	22"	17"	REGULAR	\$169.21
717SP3234	1-3/4"	X	22"	17"	REGULAR	\$257.82
717SP2202	2"	X	22"	17"	REGULAR	\$290.63

Spline Drive - X-Cutter

Part #	Size	X	O/A	Drilling	Head	List
7SPCR1058	5/8"	X	10"	6"	X-CUTTER	\$58.34
7SPCR1658	5/8"	X	16"	11"	X-CUTTER	\$67.78
7SPCR2258	5/8"	X	22"	17"	X-CUTTER	\$80.73
7SPCR2958	5/8"	X	29"	24"	X-CUTTER	\$111.96
7SPCR3658	5/8"	X	36"	31"	X-CUTTER	\$156.18
7SPCR1034	3/4"	X	10"	6"	X-CUTTER	\$67.46
7SPCR1634	3/4"	X	16"	11"	X-CUTTER	\$72.18
7SPCR2234	3/4"	X	22"	17"	X-CUTTER	\$85.46
7SPCR2934	3/4"	X	29"	24"	X-CUTTER	\$117.29
7SPCR3634	3/4"	X	36"	31"	X-CUTTER	\$162.06
7SPCR1678	7/8"	X	16"	11"	X-CUTTER	\$76.66
7SPCR2278	7/8"	X	22"	17"	X-CUTTER	\$94.43
7SPCR1601	1"	X	16"	11"	X-CUTTER	\$80.73
7SPCR2201	1"	X	22"	17"	X-CUTTER	\$101.63
7SPCR2901	1"	X	29"	24"	X-CUTTER	\$144.96
7SPCR3601	1"	X	36"	31"	X-CUTTER	\$197.41
7SPCR1618	1-1/8"	X	16"	11"	X-CUTTER	\$101.35
7SPCR2218	1-1/8"	X	22"	17"	X-CUTTER	\$132.90
7SPCR1614	1-1/4"	X	16"	11"	X-CUTTER	\$111.96
7SPCR2214	1-1/4"	X	22"	17"	X-CUTTER	\$141.41
7SPCR2914	1-1/4"	X	29"	24"	X-CUTTER	\$197.27
7SPCR3614	1-1/4"	X	36"	31"	X-CUTTER	\$214.10
7SPCR1638	1-3/8"	X	16"	11"	X-CUTTER	\$141.41
7SPCR2238	1-3/8"	X	22"	17"	X-CUTTER	\$158.79
7SPCR2212	1-1/2"	X	22"	17"	X-CUTTER	\$182.69
7SPCR3423	1-3/4"	X	23"	18"	X-CUTTER	\$276.19

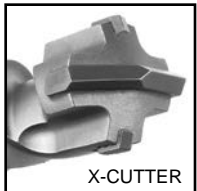
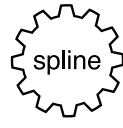

- ◆ Industrial Quality
- ◆ 4-Cutter Head
- ◆ Special Tungsten Carbide Tip
- ◆ Copper / Silver Brazing
- ◆ Fastest Dust Removal
- ◆ Fastest Drilling Speeds
- ◆ Heat Treated Body
- ◆ Clean Round Holes
- ◆ Less Vibration
- ◆ Polished Finish
- ◆ ANSI Specification

- Brick
- Stone
- Masonry
- Aggregates



BARCODED

SOLD INDIVIDUALLY.
 1 PER TUBE.





SDS-PLUS

<u>B&D</u>	<u>BOSCH</u>	<u>DEWALT</u>	<u>HILTI</u>	<u>HITACHI</u>	<u>KANGO</u>	<u>MAKITA</u>	<u>MILWAUKEE</u>	<u>METABO</u>	<u>PANASONIC</u>
5009	11207	D25012K	TE 1	DH18DL	200	BHR202	5262	6010	EY6803
5013	11210	D25023K	TE 2-A	DH22PG	285	BHR241	5263	6011	EY6813
5014	11211	D25111K	TE 2-M	DH24	327	HR160	5302	6015	EY7880
5016	11212	D25123K	TE 2-S	DH25	422	HR1821	5303	6018	
5053	11215	D25211K	TE 4-A22	DH28	426	HR1830	5312	6020	PORTER
5054	11524	D25213K	TE 6-S	DH30	430D	HR2000	5320	6021	CABLE
5056	11213RK	D25223K	TE 7-A	H30PV		HR2010	5324	6024	
5057	11221DVS	D25313K	TE 7-C	VR16		HR2400	5342	6026	639
005K-2	11222EVS/G	D25323K	TE 30	VRT22		HR2410	5359	6028	
	11224VSR	D25324K	TE 30-C-AVR			HR2420	5359	BHA18	
	11224VSR	D25404K	TE 30-M-AVR			HR2431	5360	BHE22	RAMSET
	11225VSR/H		TE 40			HR2432	5362	BHE2243	
	11228VSR		TE A-36AVR			HR2432	5363	BHE24	425
	11234VSR		TE/GP 22			HR2450	5363	BHE6015	
	11236VS					HR2450	5365	KHE24	RYOBI
	11239VS					HR2455	5366	KHE28	
	11250VSR					HR2470F	5368	KHE32	ED160
	11253VSR					HR2475	5369	UHE22	ED211
	11255VSR					HR2511	5383	UHE2650	
	11536C-1(2)					HR2811F	V28	UHE28	
	11536VSR					HR3000C			
	RH228VC					HR3210C			
	RH328VC(Q)								
	RH432VC(Q)								



SDS-MAX

<u>B&D</u>	<u>BOSCH</u>	<u>DEWALT</u>	<u>HILTI</u>	<u>HITACHI</u>	<u>MAKITA</u>	<u>MILWAUKEE</u>	<u>METABO</u>
5097	11214EVS	25600K	TE-F 52	DH38MS	HR4000C	5308	6045
5099	1223	2570K	TE-F 60	DH40MA	HR4001C	5313	KHE56
	1227	541K	TE-F 72	DH40MB	HR4002C	5314	KHE76
	1230	545K	TE-F 92	DH40MRY	HR4010C	5315	KHE96
	11216	D25501K	TE-Y 54	DH45MR	HR4500C	5317	
	11231	D25602K	TE-Y 55	DH50MRY	HR4510C	5342	
	11235	D25712K	TE-Y 56	H60HR	HR5001C	5346	
	11240	D25762K	TE-Y 70		HR5210C	5426	
	11240		TE-Y 74			5446	
	11241		TE-Y 75				
	11245		TE-Y 76				
	11263		TE 50				
	11264		TE 60				
	11245EVS		TE 70				
	11263EVS		TE 70-ATC				
	11264EVS		TE 80-ATC				
	RH850VC						



SPLINE

<u>B&D</u>	<u>BOSCH</u>	<u>DEWALT</u>	<u>HITACHI</u>	<u>KANGO</u>	<u>MAKITA</u>	<u>MILWAUKEE</u>	<u>RAMSET</u>	<u>REDHEAD</u>	<u>RYOBI</u>
5041	11202	D25651K	DH38YE2	430S	HR3851	5340-21	442	747-2	ED382
5042	11203	D25553K	DH40FR	501S	HR4040C	5309	445		EDR382
5043	11204	530K	DS50SBK	537S	HR5000	5311	475		
5044	11205	531K		750S		5316			
5045	11209	532K		950S		5317			
5059	11214	533K		978S		5318			
5093	11219					5319			
5095	11220					5321			
5096	11232					5341			
5098	11233					5343			
	11247					5344			
	11247					5347			
	11248					5348			
	11244E					5352			
	11265EVS					5345			

All the above manufacturers' names are the sole registered trade marks of their respective companies and have no affiliation with ITM whatsoever.

SDS-MAX® - Bohr Hammer

Part #	Size	X	O/A	Drilling	Head	List
SMTE1338	3/8"	X	13"	8"	REGULAR	\$45.79
SMTE1312	1/2"	X	13"	8"	REGULAR	\$44.29
SMTE1712	1/2"	X	17"	12"	REGULAR	\$55.43
SMTE2212	1/2"	X	21"	15-1/2"	REGULAR	\$58.49
SMTE1391	9/16"	X	13"	8"	REGULAR	\$68.72
SMTE2192	9/16"	X	21"	15-1/2"	REGULAR	\$89.71
SMTE1358	5/8"	X	13"	8"	X-CUTTER	\$53.44
SMTE1758	5/8"	X	17"	12"	X-CUTTER	\$60.80
SMTE2258	5/8"	X	21"	15-1/2"	X-CUTTER	\$64.61
SMTE3658	5/8"	X	36"	31"	X-CUTTER	\$139.79
SMTE2111	11/16"	X	21"	15-1/2"	X-CUTTER	\$93.42
SMTE1334	3/4"	X	13"	8"	X-CUTTER	\$55.40
SMTE1734	3/4"	X	17"	12"	X-CUTTER	\$65.63
SMTE2234	3/4"	X	21"	15-3/4"	X-CUTTER	\$72.24
SMTE3634	3/4"	X	36"	32"	X-CUTTER	\$152.62
SMTE2113	13/16"	X	21"	17"	X-CUTTER	\$99.29
SMTE1378	7/8"	X	13"	9"	X-CUTTER	\$65.23
SMTE1778	7/8"	X	17"	12"	X-CUTTER	\$74.77
SMTE2278	7/8"	X	21"	17"	X-CUTTER	\$78.85
SMTE3678	7/8"	X	36"	32"	X-CUTTER	\$201.56
SMTE1301	1"	X	13"	8"	X-CUTTER	\$71.37
SMTE1701	1"	X	17"	12"	X-CUTTER	\$82.44
SMTE2201	1"	X	21"	17"	X-CUTTER	\$86.65
SMTE3601	1"	X	36"	32"	X-CUTTER	\$214.18
SMTE2311	1-1/16"	X	23"	18"	X-CUTTER	\$117.16
SMTE1718	1-1/8"	X	17"	13"	X-CUTTER	\$94.64
SMTE2218	1-1/8"	X	21"	17"	X-CUTTER	\$111.93
SMTE3618	1-1/8"	X	36"	32"	X-CUTTER	\$242.70
SMTE2313	1-3/16"	X	23"	18"	X-CUTTER	\$144.41
SMTE1714	1-1/4"	X	15"	11"	X-CUTTER	\$122.87
SMTE2214	1-1/4"	X	23"	17"	X-CUTTER	\$131.29
SMTE3614	1-1/4"	X	36"	32"	X-CUTTER	\$256.60
SMTE1738	1-3/8"	X	17"	12"	X-CUTTER	\$137.07
SMTE2238	1-3/8"	X	23"	17"	X-CUTTER	\$144.49
SMTE3638	1-3/8"	X	36"	32"	X-CUTTER	\$289.82
SMTE1721	1-1/2"	X	17"	13"	X-CUTTER	\$169.44
SMTE2221	1-1/2"	X	23"	17"	X-CUTTER	\$214.98
SMTE2334	1-3/4"	X	23"	18"	X-CUTTER	\$304.16
SMTE2202	2"	X	23"	18"	X-CUTTER	\$337.26

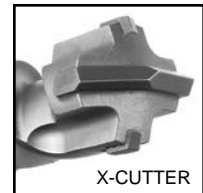

- ◆ Industrial Quality
- ◆ Special Tungsten Carbide Tip
- ◆ Copper / Silver Brazing
- ◆ Fastest Dust Removal
- ◆ Fastest Drilling Speeds
- ◆ Heat Treated Body
- ◆ Clean Round Holes
- ◆ Less Vibration
- ◆ Polished Finish
- ◆ ANSI Specification

- ➔ Brick
- ➔ Stone
- ➔ Masonry
- ➔ Aggregates



BARCODED

SOLD INDIVIDUALLY.
1 PER TUBE.

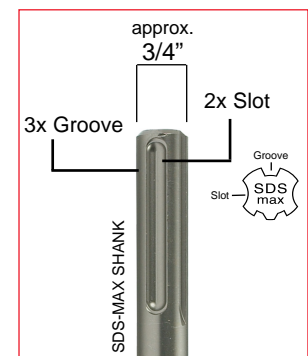

Bosch® License



Extensions on Page 88.

MAIN OFFICE
 INTERNATIONAL TOOL MANUFACTURING
 71-08 51ST. AVENUE, WOODSIDE, NY 11377
 (718) 446-0711 - (800) 247-5696 - FAX (718) 899-6553



INTERNATIONAL TOOL MANUFACTURING
 675-E-PROGRESS CENTER AVE., LAWRENCEVILLE, GA 30043
 (770) 962-5454 - (800) 229-1776 - FAX (770) 962-5869



- ◆ Industrial Quality
- ◆ 1 Piece Construction
- ◆ Special Tungsten Carbide Tip
- ◆ Copper / Silver Brazing
- ◆ Fast Drilling Speed
- ◆ Clean Round Holes
- ◆ Less Vibration
- ◆ Polished Finish

- Brick
- Stone
- Masonry
- Aggregates



BARCODED

SOLD INDIVIDUALLY.
 1 PER TUBE.



SDS-MAX® Core Cutter

Part #	Size	X	O/A	Shank	List
950CC7330	1-1/2"	X	12-1/4"	SDS-MAX	\$222.94
950CC7331	1-1/2"	X	22"	SDS-MAX	\$268.45
950CC7332	1-3/4"	X	12-1/4"	SDS-MAX	\$237.03
950CC7333	1-3/4"	X	22"	SDS-MAX	\$273.53
950CC7342	1-3/4"	X	39"	SDS-MAX	\$362.50
950CC7336	2-1/8"	X	12-1/4"	SDS-MAX	\$269.58
950CC7337	2-1/8"	X	22"	SDS-MAX	\$308.41
950CC7343	2-1/8"	X	39"	SDS-MAX	\$406.81
950CC7338	2-1/2"	X	12-1/4"	SDS-MAX	\$295.24
950CC7339	2-1/2"	X	22"	SDS-MAX	\$313.28
950CC7344	2-1/2"	X	39"	SDS-MAX	\$439.03
950CC7340	3-1/8"	X	12-1/4"	SDS-MAX	\$337.04
950CC7341	3-1/8"	X	22"	SDS-MAX	\$373.09
950CC7345	3-1/8"	X	39"	SDS-MAX	\$503.47



Spline Core Cutter

Part #	Size	X	O/A	Shank	List
900CC7201	1-1/2"	X	12-1/4"	SPLINE	\$234.01
900CC7203	1-1/2"	X	22"	SPLINE	\$281.86
900CC7220	1-3/4"	X	12-1/4"	SPLINE	\$248.92
900CC7221	2-1/8"	X	12-1/4"	SPLINE	\$290.00
900CC7217	2-1/8"	X	22"	SPLINE	\$343.81
900CC7207	2-1/2"	X	12-1/4"	SPLINE	\$312.11
900CC7209	2-1/2"	X	22"	SPLINE	\$363.27
900CC7210	3-1/8"	X	12-1/4"	SPLINE	\$398.79
900CC7212	3-1/8"	X	22"	SPLINE	\$450.47



Extensions on Page 88.

Adapters

Part #	Description	OAL	List
800RA010	SPLINE ADAPTER	7"	\$78.14
800RA020	SDS-MAX ADAPTER	7"	\$78.14



◆ 5/8" - 11 Internal Thread

Pilot Drills

Part #	Description	List
800RP124	5/8" X 4-3/4" PILOT	\$43.42
800RP174	5/8" X 6-3/4" PILOT	\$46.84
800RP255	1/2" X 6" PILOT	\$35.12



- RECOMMENDED.
- BETTER FOR DEEP DRILLING.
- FOR RATIO CORE BIT ONLY!!!

- ◆ Modular System
- ◆ Up to 6" Diameter
- ◆ Allows for Angle Drilling
- ◆ Use With or Without Spiral Flute
- ◆ Adapters Accommodate Any Combination
- ◆ Unmatched Flexibility

Cruciform™ Drill Heads

Part #	Description	OAL	List
800RC040	1-1/2" DRILL HEAD	1-1/2"	\$210.25
800RC045	1-3/4" DRILL HEAD	1-1/2"	\$242.15
800RC052	2" DRILL HEAD	1-1/2"	\$275.86
800RC065	2-5/8" DRILL HEAD	1-1/2"	\$373.33
800RC080	3-1/8" DRILL HEAD	1-1/2"	\$421.06
800RC090	3-1/2" DRILL HEAD	1-1/2"	\$491.35
800RC100	4" DRILL HEAD	1-1/2"	\$526.43
800RC110	4-1/2" DRILL HEAD	1-1/2"	\$657.94
800RC125	5" DRILL HEAD	1-1/2"	\$753.36
800RC150	6" DRILL HEAD	1-1/2"	\$1104.26



Replacement Coupler
5/8" - 11 X 2" OAL
800RT001 List \$18.87



Extensions

Part #	Description	List
800RE300	11" LONG EXTENSION	\$122.08
800RE450	18" LONG EXTENSION	\$138.64



Hard Body Spiral Flutes

Part #	Description	OAL	List
800RF145	1-1/2" FLUTE	4"	\$121.36
800RF145	1-3/4" FLUTE	4"	\$121.36
800RF152	2" FLUTE	4"	\$153.74
800RF165	2-5/8" FLUTE	4"	\$296.77
800RF180	3-1/8" FLUTE	4"	\$501.78
800RF180	3-1/2" FLUTE	4"	\$501.78



Same flute fits 1-1/2" & 1-3/4"

Same flute fits 3-1/8" & 3-1/2"

Ratio Core Bits - INTERNAL THREAD

Part #	Description	OAL	List
800RK150	1-1/2" CORE BIT	3"	\$162.24
800RK200	2" CORE BIT	3"	\$169.61
800RK250	2-1/2" CORE BIT	3"	\$202.80
800RK300	3" CORE BIT	3"	\$235.95
800RK350	3-1/2" CORE BIT	3"	\$279.13
800RK400	4" CORE BIT	3"	\$342.16
800RK450	4-1/2" CORE BIT	3"	\$430.81
800RK500	5" CORE BIT	3"	\$463.36
800RK600	6" CORE BIT	3"	\$548.78



USE PILOT DRILL
800RP255 ONLY!!!



GERMANY



All parts sold separately. Drilling through REBAR will cause damage to system.



Pilot Drill - A-TAPER FOR EXTENSION

Part #	Size	List
721PD0385	3/8" X 5" A-TAPER	\$11.63

Ejector Key

Part #	Size	List
722EJ0001	EJECTOR KEY	\$8.55



Carbide Core Bit - 4" OAL / TAPER

Part #	Size	# Teeth	List
719CB0040	1-1/2"	6	\$110.02
719CB0050	2"	6	\$130.82
719CB0065	2-1/2"	9	\$141.81
719CB0080	3" (3-1/8")	9	\$185.52
719CB0090	3-1/2"	9	\$209.28
719CB0100	4"	9	\$269.64
719CB0125	5"	12	\$377.60

INSTRUCTIONS

- 1 Wipe off oil or lubricant from the taper of the extension and the inner taper of the core bit.
- 2 Insert the pilot drill into the drive extension first.
- 3 Insert the drive extension into the core bit.
- 4 Start drilling hole until the core bit is 3/8" deep.
- 5 Use the ejector key to push out the pilot drill.
- 6 Continue drilling the hole until the material being drilled fills the core bit interior. Approximately 3-1/2" deep.
- 7 Break the drilled material inside the core bit with a chisel (if necessary.)
- 8 Return to Step 6 until desired hole depth is achieved.

These Heavy Duty Rotary Hammer Core Bits are used with either Spline or SDS-MAX electric rotary hammer machines. The special alloy steel body and Tungsten Carbide withstand continuous hammering. A pilot drill bit and extension are required.



TAPER



Extensions

SPLINE DRIVE

Part #	Size	Shank	List
720SP0008	8"	SPLINE	\$73.60
720SP0018	18"	SPLINE	\$90.58

SDS - MAX®

Part #	Size	Shank	List
720MAX008	8"	SDS-MAX	\$72.58
720MAX018	18"	SDS-MAX	\$88.69



Notice: Core Bit drilling without the use of a pilot drill bit causes excessive pressure on the taper shank system. This can result in breakage to the extension at the tapered end, especially between the two slots. Such jagged breaks are not considered defective and may not be covered under warranty.

1-Pc SDS-MAX® Core Bits

Part #	Size	X	O/A	# Teeth	Shank	List
990HH1015	1-1/2"	X	12"	4	SDS-MAX	\$233.40
990HH1025	1-1/2"	X	22"	4	SDS-MAX	\$279.57
990HH1155	1-3/4"	X	12"	6	SDS-MAX	\$246.84
990HH1165	1-3/4"	X	22"	6	SDS-MAX	\$275.88
990HH1035	2"	X	12"	6	SDS-MAX	\$255.43
990HH1045	2"	X	22"	6	SDS-MAX	\$299.65
990HH1055	2-5/8"	X	12"	8	SDS-MAX	\$290.15
990HH1065	2-5/8"	X	22"	8	SDS-MAX	\$329.81
990HH1075	3-1/8"	X	12"	8	SDS-MAX	\$350.56
990HH1085	3-1/8"	X	22"	8	SDS-MAX	\$389.97
990HH1095	3-1/2"	X	12"	10	SDS-MAX	\$369.23
990HH1105	3-1/2"	X	22"	10	SDS-MAX	\$400.34
990HH1115	4"	X	12"	10	SDS-MAX	\$431.46
990HH1125	4"	X	22"	10	SDS-MAX	\$460.50
990HH1215	5"	X	12"	14	SDS-MAX	\$485.39
990HH1135	5"	X	22"	14	SDS-MAX	\$508.20
990HH1145	6"	X	22"	18	SDS-MAX	\$674.15

1-Pc Spline Core Bits

Part #	Size	X	O/A	# Teeth	Shank	List
920HH1505	1-1/2"	X	12"	4	SPLINE	\$252.02
920HH1515	1-1/2"	X	22"	4	SPLINE	\$296.00
920HH1665	1-3/4"	X	12"	6	SPLINE	\$254.81
920HH1675	1-3/4"	X	22"	6	SPLINE	\$291.81
920HH1525	2"	X	12"	6	SPLINE	\$264.79
920HH1535	2"	X	22"	6	SPLINE	\$308.98
920HH1545	2-5/8"	X	12"	8	SPLINE	\$304.80
920HH1555	2-5/8"	X	22"	8	SPLINE	\$348.36
920HH1565	3-1/8"	X	12"	8	SPLINE	\$371.66
920HH1575	3-1/8"	X	22"	8	SPLINE	\$422.45
920HH1585	3-1/2"	X	12"	10	SPLINE	\$391.45
920HH1595	3-1/2"	X	22"	10	SPLINE	\$434.55
920HH1605	4"	X	12"	10	SPLINE	\$448.29
920HH1615	4"	X	22"	10	SPLINE	\$490.58
920HH1625	5"	X	12"	14	SPLINE	\$511.73
920HH1635	5"	X	22"	14	SPLINE	\$541.33
920HH1655	6"	X	22"	18	SPLINE	\$714.73



Pilot Drill & Key - REPLACEMENT PARTS

Part #	Size	List
900PD1143	7/16" X 4-3/4" PILOT DRILL	\$10.27
900DK7006	3/8" ROUND DRIFT KEY	\$9.80

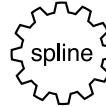

- ◆ Industrial Quality
- ◆ 1 Piece Construction
- ◆ Special Tungsten Carbide Tip
- ◆ Copper / Silver Brazing
- ◆ Clean Round Holes
- ◆ Less Vibration
- ◆ Polished Finish

- Brick
- Stone
- Masonry
- Aggregates

Each Core Bit Includes Pilot Drill & Key



BARCODED

SOLD INDIVIDUALLY.
1 PER TUBE.





- ◆ Industrial Quality
- ◆ Special Tungsten Carbide Tip
- ◆ Copper / Silver Brazing
- ◆ Special Flute Design Improves Penetration without Blow Back or Compacting
- ◆ Fastest Dust Removal
- ◆ Fastest Drilling Speeds
- ◆ Heat Treated Body
- ◆ Clean Round Holes
- ◆ Less Vibration
- ◆ Polished Finish
- ◆ ANSI Specification

- Brick
- Stone
- Masonry
- Aggregates



BARCODED

SOLD INDIVIDUALLY.
 1 PER CLIP.

715Sxxxxx-B
Bulk Pack/Tube



SDS-PLUS - Bohr Hammer

Part #	Size	X	O/A	Drilling	Head	Qty	List
715S41064	5/32"	X	4-1/2"	2"	4-PLUS	1	\$5.97
715S61064	5/32"	X	6-1/4"	4"	4-PLUS	1	\$6.81
715S61064-B	5/32"	X	6-1/4"	4"	4-PLUS	25	\$161.74
715S41264	3/16"	X	4-1/2"	2"	4-PLUS	1	\$5.97
715S41264-B	3/16"	X	4-1/2"	2"	4-PLUS	25	\$141.79
715S61264	3/16"	X	6-1/4"	4"	4-PLUS	1	\$6.81
715S61264-B	3/16"	X	6-1/4"	4"	4-PLUS	25	\$161.74
715S81264	3/16"	X	8-1/4"	6"	4-PLUS	1	\$9.42
715S81264-B	3/16"	X	8-1/4"	6"	4-PLUS	25	\$223.73
715S10316	3/16"	X	10"	8"	4-PLUS	1	\$12.50
715S12316	3/16"	X	12"	10"	4-PLUS	1	\$15.50
715S14316	3/16"	X	14"	12"	4-PLUS	1	\$22.59
715S16316	3/16"	X	16"	14"	4-PLUS	1	\$29.66
715S41464	7/32"	X	4-1/2"	2"	4-PLUS	1	\$6.99
715S61464	7/32"	X	6-1/4"	4"	4-PLUS	1	\$7.22
715S81464	7/32"	X	8-1/4"	6"	4-PLUS	1	\$8.97
715S11732	7/32"	X	11"	9"	4-PLUS	1	\$16.21
715S16732	7/32"	X	16"	14"	4-PLUS	1	\$26.21
715S41664	1/4"	X	4-1/2"	2"	4-PLUS	1	\$5.97
715S41664-B	1/4"	X	4-1/2"	2"	4-PLUS	25	\$141.79
715S61664	1/4"	X	6-1/4"	4"	4-PLUS	1	\$6.81
715S61664-B	1/4"	X	6-1/4"	4"	4-PLUS	25	\$148.44
715S81664	1/4"	X	8-1/4"	6"	4-PLUS	1	\$8.97
715S81664-B	1/4"	X	8-1/4"	6"	4-PLUS	25	\$213.04
715S11014	1/4"	X	11"	9"	4-PLUS	1	\$11.45
715S14014	1/4"	X	14"	12"	4-PLUS	1	\$22.45
715S16014	1/4"	X	16"	14"	4-PLUS	1	\$24.22
715S20014	1/4"	X	20"	18"	4-PLUS	1	\$29.04
715S62064	5/16"	X	6-1/4"	4"	4-PLUS	1	\$8.31
715S62064-B	5/16"	X	6-1/4"	4"	4-PLUS	25	\$197.36
715S82064	5/16"	X	8-1/4"	6"	4-PLUS	1	\$11.02
715S12516	5/16"	X	12"	10"	4-PLUS	1	\$20.75
715S62464	3/8"	X	6-1/4"	4"	4-PLUS	1	\$9.03
715S62464-B	3/8"	X	6-1/4"	4"	4-PLUS	25	\$214.46
715S82464	3/8"	X	8-1/4"	6"	4-PLUS	1	\$10.42
715S10038	3/8"	X	10-1/4"	8"	4-PLUS	1	\$14.61
715S12038	3/8"	X	12-1/4"	10"	4-PLUS	1	\$18.53
715S12038-B	3/8"	X	12-1/4"	10"	4-PLUS	25	\$176.04
715S18038	3/8"	X	18"	16"	4-PLUS	1	\$26.72
715S24038	3/8"	X	24"	22"	4-PLUS	1	\$34.39
715S62864	7/16"	X	6-1/4"	4"	4-PLUS	1	\$12.44
715S10716	7/16"	X	10-1/4"	8"	4-PLUS	1	\$17.56
715S12716	7/16"	X	12-1/4"	10"	4-PLUS	1	\$19.56
715S18716	7/16"	X	18"	16"	4-PLUS	1	\$29.33
715S63264	1/2"	X	6-1/4"	4"	4-PLUS	1	\$10.39
715S63264-B	1/2"	X	6-1/4"	4"	4-PLUS	25	\$246.76
715S10012	1/2"	X	10-1/4"	8"	4-PLUS	1	\$17.93
715S12012	1/2"	X	12-1/4"	10"	4-PLUS	1	\$19.56
715S12012-B	1/2"	X	12-1/4"	10"	4-PLUS	10	\$185.82
715S12018	1/2"	X	18"	16"	4-PLUS	1	\$24.02
715S12024	1/2"	X	24"	22"	4-PLUS	1	\$44.10



SDS-PLUS - Bohr Hammer

Part #	Size	X	O/A	Drilling	Head	Qty	List
715S63664	9/16"	X	6-1/4"	4"	4-PLUS	1	\$16.10
715S10916	9/16"	X	10-1/4"	8"	4-PLUS	1	\$20.79
715S12916	9/16"	X	12-1/4"	10"	4-PLUS	1	\$24.15
715S18916	9/16"	X	18"	16"	4-PLUS	1	\$27.60
715S64064	5/8"	X	6-1/4"	4"	4-PLUS	1	\$12.83
715S84064	5/8"	X	8"	6"	4-PLUS	1	\$18.43
715S84064-B	5/8"	X	8"	6"	4-PLUS	10	\$175.09
715S12058	5/8"	X	12"	10"	4-PLUS	1	\$26.72
715S18058	5/8"	X	18"	16"	4-PLUS	1	\$38.19
715S24058	5/8"	X	24"	22"	4-PLUS	1	\$47.21
715S14464	11/16"	X	12"	10"	REGULAR	1	\$35.75
715S84864	3/4"	X	8"	6"	REGULAR	1	\$23.72
715S84864-B	3/4"	X	8"	6"	REGULAR	10	\$225.34
715S10034	3/4"	X	10"	8"	REGULAR	1	\$29.26
715S12034	3/4"	X	12"	10"	REGULAR	1	\$34.61
715S12034-B	3/4"	X	12"	10"	REGULAR	5	\$164.40
715S18034	3/4"	X	18"	16"	REGULAR	1	\$46.35
715S24034	3/4"	X	24"	22"	REGULAR	1	\$60.67
715S85664	7/8"	X	8"	6"	REGULAR	1	\$41.59
715S85664-B	7/8"	X	8"	6"	REGULAR	5	\$197.55
715S10078	7/8"	X	10"	8"	REGULAR	1	\$44.48
715S12078	7/8"	X	12"	10"	REGULAR	1	\$46.93
715S12078-B	7/8"	X	12"	10"	REGULAR	5	\$222.92
715S18078	7/8"	X	18"	14"	REGULAR	1	\$52.01
715S86464	1"	X	8"	6"	REGULAR	1	\$46.24
715S10001	1"	X	10"	8"	REGULAR	1	\$51.88
715S10001-B	1"	X	10"	8"	REGULAR	5	\$246.43
715S12001	1"	X	12"	10"	REGULAR	1	\$54.72
715S18001	1"	X	18"	16"	REGULAR	1	\$73.33
715S22018	1-1/8"	X	10"	8"	X-CUTTER	1	\$89.60
715S24014	1-1/4"	X	18"	16"	X-CUTTER	1	\$99.11



3 Head Styles:

Depending on diameter, different carbide tips offer advantages:



4-PLUS

A new, fast, & tough carbide tip provides long life, easy centering, and fast drilling through all aggregates, concrete, masonry, brick, stone, and rebar if straight on.



REGULAR

Traditional Tungsten Carbide Tip with Copper Silver Brazing for clean drilling through all aggregates, concrete, masonry, brick, & stone. Regular heads are found on SDS-PLUS sizes over 5/8".



X-CUTTER

4 Sided Traditional Tungsten Carbide Tip with Copper Silver Brazing for *Super Fast* clean drilling through all aggregates, concrete, masonry, brick, & stone. Will not cut rebar!

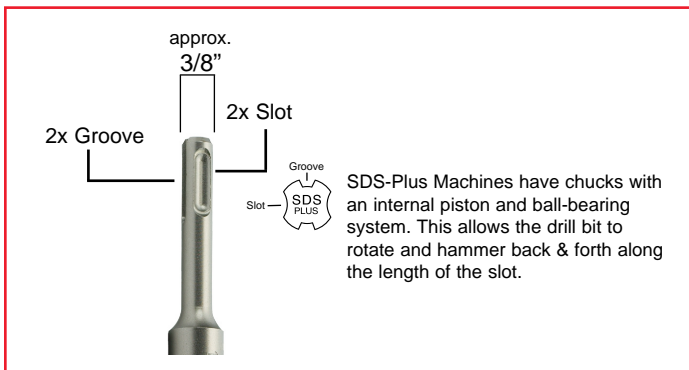

Drills REBAR!!!



- ◆ 50% More Holes
- ◆ Drills Rebar
- ◆ No "sticking"
- ◆ Less Breakage
- ◆ Less Vibration

- Brick
- Stone
- Masonry
- Aggregates



SOLD INDIVIDUALLY.
 1 PER CLIP.



SDS 4X4 eVolution™ - Bohr Hammer

Part #	Size	X	O/A	Drilling	Head	List
EVL41264	3/16"	X	4"	2"	4X4	\$10.03
EVL61264	3/16"	X	6"	4"	4X4	\$11.20
EVL81264	3/16"	X	8"	6"	4X4	\$14.70
EVL10316	3/16"	X	10"	8"	4X4	\$20.92
EVL12316	3/16"	X	12"	10"	4X4	\$25.78
EVL41664	1/4"	X	4"	2"	4X4	\$9.84
EVL61664	1/4"	X	6"	4"	4X4	\$10.81
EVL81664	1/4"	X	8"	6"	4X4	\$13.92
EVL10014	1/4"	X	10"	8"	4X4	\$21.31
EVL12014	1/4"	X	12"	10"	4X4	\$29.67
EVL62064	5/16"	X	6"	4"	4X4	\$12.56
EVL12516	5/16"	X	12"	10"	4X4	\$23.64
EVL18516	5/16"	X	18"	16"	4X4	\$34.92
EVL62464	3/8"	X	6"	4"	4X4	\$13.92
EVL12038	3/8"	X	12"	10"	4X4	\$23.64
EVL18038	3/8"	X	18"	16"	4X4	\$37.84
EVL62864	7/16"	X	6"	4"	4X4	\$18.78
EVL12716	7/16"	X	12"	10"	4X4	\$27.34
EVL18716	7/16"	X	18"	16"	4X4	\$38.81
EVL63264	1/2"	X	6"	4"	4X4	\$18.28
EVL12012	1/2"	X	12"	10"	4X4	\$29.09
EVL18012	1/2"	X	18"	16"	4X4	\$39.39
EVL63664	9/16"	X	6"	4"	4X4	\$24.69
EVL12916	9/16"	X	12"	10"	4X4	\$36.09
EVL18916	9/16"	X	18"	16"	4X4	\$49.51



4X4-Cutter

- ◆ 4 x 90° Head Symmetry.
- ◆ One-piece, Solid Carbide Tip.
- ◆ Centering Tip for Pinpoint Accuracy.
- ◆ Reinforcing Chamfers.
- ◆ Maximum Carbide / Steel Interface.
- ◆ Low Vibration for Increased Rotational Stability.
- ◆ ANSI Specification.

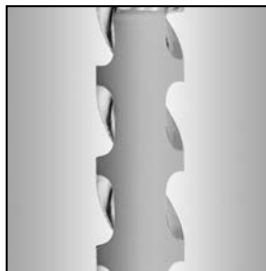

4X4-Flute

- ◆ 4 Symmetrical Functioning Spiral Ridges.
- ◆ Faster-Than-Ever Dust Removal.
- ◆ Balanced Load Distribution.
- ◆ Optimized Core Ensures Impact Durability and Rotational Stability.
- ◆ High Break Resistance.
- ◆ Less Vibration.

50% More Holes Than a 2-Cutter!

MAIN OFFICE
 INTERNATIONAL TOOL MANUFACTURING
 71-08 51ST. AVENUE, WOODSIDE, NY 11377
 (718) 446-0711 - (800) 247-5696 - FAX (718) 899-6553



INTERNATIONAL TOOL MANUFACTURING
 675-E-PROGRESS CENTER AVE., LAWRENCEVILLE, GA 30043
 (770) 962-5454 - (800) 229-1776 - FAX (770) 962-5869

REDLINE



SDS REDLINE™ - Bohr Hammer

Part #	Size	X	O/A	Drilling	QTY.	List
RL-41064	5/32"	X	4-1/4"	2"	1	\$3.99
RL-61064	5/32"	X	6-1/4"	4"	1	\$4.64
RL-61064-B	5/32"	X	6-1/4"	4"	25	\$108.10
RL-41264	3/16"	X	4-1/4"	2"	1	\$3.41
RL-61264	3/16"	X	6-1/4"	4"	1	\$4.52
RL-61264-B	3/16"	X	6-1/4"	4"	25	\$105.23
RL-81264	3/16"	X	8-1/4"	6"	1	\$6.29
RL-81264-B	3/16"	X	8-1/4"	6"	25	\$148.47
RL-41664	1/4"	X	4-1/4"	2"	1	\$3.34
RL-41664-B	1/4"	X	4-1/4"	2"	25	\$76.48
RL-61664	1/4"	X	6-1/4"	4"	1	\$3.99
RL-61664-B	1/4"	X	6-1/4"	4"	25	\$91.81
RL-91664	1/4"	X	8-1/4"	6"	1	\$5.52
RL-91664-B	1/4"	X	8-1/4"	6"	25	\$129.57
RL-62064	5/16"	X	6-1/4"	4"	1	\$4.37
RL-62064-B	5/16"	X	6-1/4"	4"	25	\$102.35
RL-62464	3/8"	X	6-1/4"	4"	1	\$4.79
RL-62464-B	3/8"	X	6-1/4"	4"	25	\$111.94
RL-12038	3/8"	X	12-1/4"	10"	1	\$9.58
RL-12038-B	3/8"	X	12-1/4"	10"	10	\$93.73
RL-63264	1/2"	X	6-1/4"	4"	1	\$6.25
RL-63264-B	1/2"	X	6-1/4"	4"	25	\$149.12
RL-12012	1/2"	X	12-1/4"	10"	1	\$11.00
RL-12012-B	1/2"	X	12-1/4"	10"	10	\$107.53
RL-63664	9/16"	X	6-1/4"	4"	1	\$9.58
RL-94064	5/8"	X	8-1/4"	6"	1	\$13.30
RL-94064-B	5/8"	X	8-1/4"	6"	10	\$129.18
RL-12058	5/8"	X	12"	10"	1	\$17.90
RL-94864	3/4"	X	8"	6"	1	\$19.05
RL-94864-B	3/4"	X	8"	6"	10	\$188.60
RL-12034	3/4"	X	12"	10"	1	\$24.46
RL-12034-B	3/4"	X	12"	10"	5	\$121.90
RL-95664	7/8"	X	8"	6"	1	\$28.25
RL-95664-B	7/8"	X	8"	6"	5	\$140.68
RL-12078	7/8"	X	12"	10"	1	\$32.12
RL-12078-B	7/8"	X	12"	10"	5	\$160.62
RL-10001	1"	X	10"	8"	1	\$36.23
RL-10001-B	1"	X	10"	8"	5	\$181.13



For General Purpose Hammer Drilling In soft / medium / hard aggregates.

- ◆ ANSI Specification.
- ◆ Made in GERMANY

- Masonry
- Stone
- Brick
- Aggregates



BARCODED

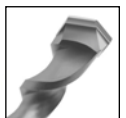

This German Made Hammer Drill is a return to the original flute design of the 1970's. It's easier to make with today's high-tech fabrication machines and costs less. A very good drill for light to medium aggregates. Competes perfectly with Asian imports.



X-Tendr™ - MAX to MAX SHANK ADAPTER

Part #	Description	List
XT6700	Adapter (1-1/4" x 7-1/2")	\$344.17
XT6750	Adapter Grease (Tube)	\$6.50



Shown: Spline Shaft

X-Tendr™ Extension Shafts

Part #	O/A	Shank	List
XT6701	12-1/2"	SDS-MAX	\$50.94
XT6702	30"	SDS-MAX	\$62.61
XT6703	44"	SDS-MAX	\$78.17
XT6708	12-1/2"	SPLINE	\$58.72
XT6709	30"	SPLINE	\$73.50

Drill bit extension system for all SDS-Max & Spline machines.

- ◆ Extend any SDS-MAX tool
- ◆ Quick & Safe connection
- ◆ Simple to use
- ◆ No energy loss
- ◆ No weak points
- ◆ Saves time & money
- ◆ Reduces tool requirements

How it works:

- X-Tendr™ Adapter has double locking SDS-MAX inputs.
- All EXTENSION SHAFTS have 1 SDS-MAX end which locks into X-Tendr Adapter. Other end can be inserted into either an SDS-MAX or Spline machine.
- Extend ANY SDS-MAX drill bit, core bit, concrete cutter, drill head, or chisel.
- Reach of X-Tendr™ system limited to 1 adapter and 1 extension.

Use your SDS-Plus drill bits in larger SDS-MAX® or Spline Drive Machines:



SDS-MAX® to SDS-PLUS

Part #	Description	List
725MAX001	SDS-MAX To SDS-Plus Adapter	\$114.15



Spline to SDS-PLUS

Part #	Description	List
725SP001	Spline To SDS-Plus Adapter	\$118.12



Replacement Kit - FOR ADAPTERS

Part #	Description	List
715KIT001	Gaskets & Ball Bearings	\$4.50



MAIN OFFICE
 INTERNATIONAL TOOL MANUFACTURING
 71-08 51ST. AVENUE, WOODSIDE, NY 11377
 (718) 446-0711 - (800) 247-5696 - FAX (718) 899-6553



INTERNATIONAL TOOL MANUFACTURING
 675-E-PROGRESS CENTER AVE., LAWRENCEVILLE, GA 30043
 (770) 962-5454 - (800) 229-1776 - FAX (770) 962-5869



Half Flat Shank

Concrete Screw System

Concrete Bits - FOR CONCRETE SCREWS

Part #	Size	x	O/A	Screw	Qty.	List
602TC0503	5/32"	X	3-1/2"	12	50	\$3.17
602TC0500	5/32"	X	4-1/2"	12	50	\$3.31
602TC0505	5/32"	X	5-1/2"	12	50	\$3.60
602TC0603	3/16"	X	3-1/2"	14	50	\$3.60
602TC0604	3/16"	X	4-1/2"	14	50	\$3.73
602TC0605	3/16"	X	5-1/2"	14	50	\$4.01
602TC0606	3/16"	X	6-3/4"	14	50	\$4.72
602TC0607	3/16"	X	7-5/8"	14	50	\$5.67

- ◆ Industrial Quality
- ◆ Tungsten Carbide Tip
- ◆ ANSI Specification



Each concrete screw carbide drill bit is precisely ground to match a certain tolerance to assure proper hole diameter and to achieve maximum thread holding power. The flat on the shank fits all drill adapters. The drill bit is specially heat treated to make it very durable.



Concrete Screw System

SDS-HEX Bits - FOR CONCRETE SCREWS

Part #	Size	x	O/A	Drilling	Qty.	List
HEX5325	5/32"	X	5"	2-1/2"	1	\$10.92
HEX5327	5/32"	X	7"	4-1/2"	1	\$12.17
HEX3165	3/16"	X	5"	2-1/2"	1	\$10.92
HEX3167	3/16"	X	7"	4-1/2"	1	\$12.17
HEX2345	.234	X	5"	2-1/2"	1	\$10.92
HEX2347	.234	X	7"	4-1/2"	1	\$12.17

- ◆ Industrial Quality
- ◆ Special Tungsten Carbide Tip
- ◆ Copper / Silver Brazing
- ◆ Polished Finish
- ◆ ANSI Specification



SDS-HEX Rotary Hammer drill bits are specifically designed to be used in concrete screw installation. These SDS bits have a special 5/16" HEX shoulder for use with standard concrete Installation sleeves, which eliminate the need for drill adapters. The benefits of using an SDS machine rather than a standard rotation drill means a decrease in operation time of nearly 50%.

SEE BELOW FOR INSTALLATION KIT

Installation Kit

Part #	Description	List
602TC1000	Installation Kit	\$55.00

- INCLUDES:**
- 1/4" Magnetic Driver
 - 5/16" Magnetic Driver
 - Phillips Bit Adapter
 - Masonry Drill Adapter 6-1/2" Sleeve
 - 1/8" Hex Key
 - Phillips #2 x 1" Insert
 - Phillips #3 x 1" Insert

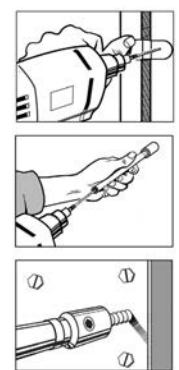

- ◆ Red Case
- ◆ Black Hardware

This Installation Kit is Suitable for both Standard Concrete Bits & SDS-HEX Rotary Hammer Bits.

Concrete Screw System

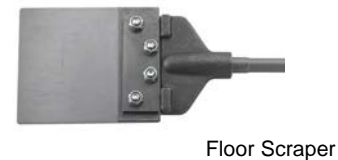
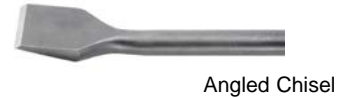

round
hex



NOTE: Spline Drive chisels have rounded hex shanks to work effectively in Spline Drive machines made with and without rotation / hammer only switches.

Spline Drive Chisels

Part #	Size	Description	List
5000BP	12"	Bull Point	\$18.04
5005BP	18"	Bull Point	\$22.48
5010FC	1" x 12"	Flat Chisel	\$18.04
5015FC	1" x 18"	Flat Chisel	\$22.48
5020SC	1-1/2" x 12"	Scaling Chisel	\$26.98
5025SC	2" x 12"	Scaling Chisel	\$34.13
5030SC	3" x 12"	Scaling Chisel	\$37.77
5035AC	2" x 12"	Angled Chisel	\$55.24
5040SL	1-1/8" x 12"	Slotting Chisel	\$47.18
5045BT	1-7/8" x 9-7/8"	Bushing Tool	\$135.98
5050GR	7/8" x 10-1/2"	Ground Rod Driver	\$125.90
5055PH	3-1/2" x 16"	Asphalt Cutter	\$161.88
5060SM	1-1/8" x 12"	Seam Tool	\$44.97
5065CS	5-3/8" x 16"	Clay Spade	\$172.15
5070FS	6" x 25"	Floor Scraper	\$485.63



SDS
max



SDS-MAX® Chisels

Part #	Size	Description	List
7000BP	12"	Bull Point	\$20.81
7005BP	18"	Bull Point	\$26.09
7010FC	1" x 12"	Flat Chisel	\$20.81
7015FC	1" x 18"	Flat Chisel	\$26.09
7020SC	1-1/2" x 12"	Scaling Chisel	\$32.63
7028FC	2" x 16"	Scaling Chisel	\$45.50
7025SC	2" x 12"	Scaling Chisel	\$34.13
7030SC	3" x 12"	Scaling Chisel	\$42.91
7035AC	2" x 12"	Angled Chisel	\$55.24
7040SL	1-1/8" x 12"	Slotting Chisel	\$45.79
7045BT	1-7/8" x 9-7/8"	Bushing Tool	\$137.36
7050GR	7/8" x 10-1/4"	Ground Rod Driver	\$124.62
7055PH	3-1/2" x 16"	Asphalt Cutter	\$167.01
7060SM	1-1/8" x 12"	Seam Tool	\$45.99
7065CS	5-3/8" x 16"	Clay Spade	\$170.87
7070FS	6" x 25"	Floor Scraper	\$485.63
7075GC	1" x 12"	Gouge Chisel	\$70.66

FS-6B	Replacement Blade (Floor Scraper)	\$22.20
FS-6NUT	Replacement Nuts & Bolts (Floor Scraper)	\$37.99





SDS-PLUS Chisels

Part #	Size	Description	List
3100BP	10"	Bull Point	\$21.37
3110FC	3/4" x 10"	Flat Chisel	\$21.37
3115SC	1-1/2" x 10"	Scaling Chisel	\$40.24
3120GC	7/8" x 10"	Gouge Chisel	\$38.54
3125WC	3/8" x 7"	Wood Chisel	\$39.31
3130WC	1/2" x 7"	Wood Chisel	\$41.88
3140WC	3/4" x 7"	Wood Chisel	\$45.48
3150WC	1" x 7"	Wood Chisel	\$51.13
3175TC	3" x 6-1/2"	Tile Chisel	\$40.85



Gouge



Wood



Tile

3/4" HEX Chisels

Part #	Size	Description	List
6010HEX	12"	3/4" Hex Bull Point	\$18.59
6015HEX	18"	3/4" Hex Bull Point	\$23.59
6020HEX	1" x 12"	3/4" Hex Flat Chisel	\$18.59
6025HEX	1" x 18"	3/4" Hex Flat Chisel	\$23.59
6030HEX	2" x 12"	3/4" Hex Scaling Chisel	\$35.20
6035HEX	3" x 12"	3/4" Hex Scaling Chisel	\$40.85
6040HEX	3-1/2" x 16"	3/4" Hex Asphalt Cutter	\$161.88
6045HEX	7/8" x 10-1/4"	3/4" Hex Ground Rod Dr.	\$138.49
6050HEX	1-7/8" x 9-7/8"	3/4" Hex Bushing Tool	\$139.52
6055HEX	5-3/8" x 16"	3/4" Hex Clay Spade	\$172.92
6060HEX	6" x 25"	3/4" Hex Floor Scraper	\$485.63



Black & Decker®
5021K

Dewalt®
5021k, DW558

Bosch®
11301 - 11302 - 11305

Hitachi®
H55SC

Milwaukee®
5335

Makita®
HM1211B

1-1/8" HEX Chisels

Part #	Size	Description	List
8020HBP	20"	1-1/8" Hex Bull Point	\$65.21
8030HFC	1-1/4" x 20"	1-1/8" Hex Flat Chisel	\$66.32
8040HSC	3" x 20"	1-1/8" Hex Scaling Chisel	\$95.74
8050HPH	5" x 17"	1-1/8" Hex Asphalt Cutter	\$215.06
8060HGR	1" x 15"	1-1/8" Hex Ground Rod Dr.	\$158.18
8070HCS	5-3/8" x 20"	1-1/8" Hex Clay Spade	\$219.23



Black & Decker®
5027

Hitachi®
H65 - H85 - H905SB

Bosch®
BRUTE 11304

Makita®
HM1303B
HM1500B
HM1800

Milwaukee®
5338

Wacker®
EH27

Kango®
2500



1-1/8" HEX Shank Chisels come with Internal locks for Demolition Hammers and External Collars for Pneumatic Hammers.

Tamping Plate & Shanks

Part #	Size	Description	List
510SPL	12"	Spline Tamping Shank	\$59.10
520MAX	12"	SDS-Max Tamping Shank	\$59.10
530HEX	12"	3/4" Hex Tamper Shank	\$59.10
550STP	5" Sq.	Tamping Plate	\$124.10





SHANK
Rotation
Only!

Rebar Cutter - SDS-PLUS SHANK

Part #	Size	OAL	RPM	List
RBS-6	3/8"	8"	850-1200	\$50.53
RBS-8	1/2"	12"	850-1200	\$52.89
RBS-9	9/16"	12"	850-1200	\$55.25
RBS-10	5/8"	12"	750-1000	\$67.06
RBS-11	11/16"	12"	750-1000	\$71.78
RBS-12	3/4"	12"	600-850	\$74.14
RBS-13	13/16"	12"	600-850	\$90.67
RBS-14	7/8"	12"	600-850	\$104.83
RBS-16	1"	12"	500-750	\$111.92
RBS-18	1-1/8"	12"	500-750	\$119.00
RBS-20	1-1/4"	12"	450-600	\$126.08
RBS-22	1-3/8"	12"	450-600	\$137.89
RBS-24	1-1/2"	12"	350-500	\$144.97
RBS-28	1-3/4"	12"	350-500	\$166.22
RBS-32	2"	12"	350-500	\$232.33
RBS-40	2-1/2"	12"	350-500	\$255.94

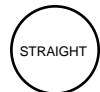

SHANK

Rebar Cutter - STRAIGHT SHANK

Part #	Size	OAL	RPM	List
RBC0838	3/8"	8"	850-1200	\$43.13
RBC1212	1/2"	12"	850-1200	\$45.52
RBC1916	9/16"	12"	850-1200	\$47.93
RBC1258	5/8"	12"	750-1000	\$59.90
RBC1858	5/8"	18"	750-1000	\$79.07
RBC1116	11/16"	12"	750-1000	\$64.70
RBC1234	3/4"	12"	600-850	\$67.09
RBC1834	3/4"	18"	600-850	\$88.65
RBC1316	13/16"	12"	600-850	\$81.46
RBC1278	7/8"	12"	600-850	\$95.84
RBC1201	1"	12"	500-750	\$103.03
RBC1218	1-1/8"	12"	500-750	\$110.22
RBC1214	1-1/4"	12"	450-600	\$117.41
RBC1238	1-3/8"	12"	450-600	\$129.39
RBC1112	1-1/2"	12"	350-500	\$136.58
RBC1134	1-3/4"	12"	350-500	\$158.14
RBC1202	2"	12"	350-500	\$268.36
RBC1222	2-1/2"	12"	350-500	\$316.28

HEAD SIZES

7/8" → 1-3/4"
2" → 2-1/2"

THREAD

1/2"-13
3/4"-10

Made In



What to do when you encounter rebar:

- 1 STOP DRILLING!!!** The sound of a rotary hammer or a carbide hammer drill bit hitting steel is much higher than when cutting concrete.
- Remove the drill bit from the hole.
- Mount a rebar cutter of the same diameter as the hole in an SDS-Plus Hammer Drill with the selector in the "rotary only" position.
- Insert the rebar cutter into the hole and begin drilling at the suggested RPM speed only. Apply just enough pressure to grind away at the rebar. **Do Not Use Excessive Speed or Pressure on the Machine** - this will either damage or break the rebar cutter.
- Once rebar is cut through, remove the rebar cutter from the hole and continue drilling with a rotary hammer or carbide hammer drill bit.

- Carbide cutters are brazed in place to keep Rebar Cutter from enlarging existing hole.

SOLD INDIVIDUALLY.
1 PER TUBE.



REMINDER:

Rebar Cutters are problem solvers only. A 1/2" Rebar Cutter drilling through #6 (3/4") rebar dead center may result in 5 to 10 holes being drilled provided correct speed and pressure are utilized. It is not uncommon for only one piece of rebar to be cut per Rebar Cutter. Rebar Cutters *should not* be used for drilling concrete.

Rebar Cutters are not warranted for replacement or repair.



BARCODED

MAIN OFFICE
 INTERNATIONAL TOOL MANUFACTURING
 71-08 51ST. AVENUE, WOODSIDE, NY 11377
 (718) 446-0711 - (800) 247-5696 - FAX (718) 899-6553



INTERNATIONAL TOOL MANUFACTURING
 675-E-PROGRESS CENTER AVE., LAWRENCEVILLE, GA 30043
 (770) 962-5454 - (800) 229-1776 - FAX (770) 962-5869



- Industrial Quality
- For Dry & Wet Use
- Individually Blister Carded



ITM Diamond Cutting Wheels are great for general contractor work. Each wheel comes with interchangeable adapters for use in virtually all hand-held saws and angle grinders.

4" TUCK POINT DIAMOND CUTTING WHEEL	
4" Part # TPS40 List \$66.64	<ul style="list-style-type: none"> • DRY TYPE • DIAMETER: 4" ± 0.70MM / 4-1/2" ± 0.70MM • TEETH THICKNESS: 0.25" (-0.00/+0.20MM) • 28 CRMO Body / LASER WELDED BLADE • 20MM ROUND ARBOR W/ 5/8" BUSHING ADAPTER (SOLID BRASS) • 20-25% CONCENTRATION OF DIAMOND GRAIN • 13,700 RPM MAXIMUM



4-1/2" TUCK POINT DIAMOND CUTTING WHEEL	
4-1/2" Part # TPS45 List \$77.75	<ul style="list-style-type: none"> • DRY TYPE • DIAMETER: 4-1/2" ± 0.70MM • TEETH THICKNESS: 0.25" (-0.00/+0.20MM) • 28 CRMO Body / LASER WELDED BLADE • 20MM ROUND ARBOR W/ 5/8" BUSHING ADAPTER (SOLID BRASS) • 20-25% CONCENTRATION OF DIAMOND GRAIN • 13,700 RPM MAXIMUM





4" CONTINUOUS RIM DIAMOND CUTTING WHEEL

Part # DCR40

List \$14.58

- DRY & WET TYPE
- DIAMETER: 4" ± 0.70MM
- TEETH THICKNESS: 0.08" (-0.00/+0.20MM)
- 65MN BODY
- 7/8" ROUND ARBOR W/ 20MM & 5/8" BUSHING ADAPTER (SOLID BRASS)
- 20-25% CONCENTRATION OF DIAMOND GRAIN
- 13,700 RPM MAXIMUM



4-1/2" CONTINUOUS RIM DIAMOND CUTTING WHEEL

Part # DCR45

List \$17.36

- DRY & WET TYPE
- DIAMETER: 4-1/2" ± 0.70MM
- TEETH THICKNESS: 0.08" (-0.00/+0.20MM)
- 65MN BODY
- 7/8" ROUND ARBOR W/ 20MM & 5/8" BUSHING ADAPTER (SOLID BRASS)
- 20-25% CONCENTRATION OF DIAMOND GRAIN
- 13,300 RPM MAXIMUM



7" CONTINUOUS RIM DIAMOND CUTTING WHEEL

Part # DCR70

List \$39.58

- DRY & WET TYPE
- DIAMETER: 7" ± 0.70MM
- TEETH THICKNESS: 0.08" (-0.00/+0.20MM)
- 65MN BODY
- 7/8" ROUND ARBOR W/ 20MM & 5/8" BUSHING ADAPTER (SOLID BRASS)
- 20-25% CONCENTRATION OF DIAMOND GRAIN
- 8,400 RPM MAXIMUM



4" TURBO DIAMOND CUTTING WHEEL

Part # DTU40

List \$16.06

- DRY & WET TYPE
- DIAMETER: 4" ± 0.70MM
- TEETH THICKNESS: 0.08" (-0.00/+0.20MM)
- 65MN BODY
- 7/8" ROUND ARBOR W/ 20MM & 5/8" BUSHING ADAPTER (SOLID BRASS)
- 20-25% CONCENTRATION OF DIAMOND GRAIN
- 13,700 RPM MAXIMUM



4-1/2" TURBO DIAMOND CUTTING WHEEL

Part # DTU45

List \$20.18

- DRY & WET TYPE
- DIAMETER: 4-1/2" ± 0.70MM
- TEETH THICKNESS: 0.08" (-0.00/+0.20MM)
- 65MN BODY
- 7/8" ROUND ARBOR W/ 20MM & 5/8" BUSHING ADAPTER (SOLID BRASS)
- 20-25% CONCENTRATION OF DIAMOND GRAIN
- 13,300 RPM MAXIMUM







7" TURBO DIAMOND CUTTING WHEEL

Part # DTU70

List \$46.76

- DRY & WET TYPE
- DIAMETER: 7" ± 0.70MM
- TEETH THICKNESS: 0.08" (-0.00/+0.20MM)
- 65MN BODY
- 7/8" ROUND ARBOR W/ 20MM & 5/8" BUSHING ADAPTER (SOLID BRASS)
- 20-25% CONCENTRATION OF DIAMOND GRAIN
- 8,400 RPM MAXIMUM



4" SEGMENTED DIAMOND CUTTING WHEEL		
Part # DCS40 List \$14.58	<ul style="list-style-type: none"> • DRY TYPE • DIAMETER: 4" ± 0.70MM • TEETH THICKNESS: 0.08" (-0.00/+0.20MM) • 65MN BODY • 7/8" ROUND ARBOR W/ 20MM & 5/8" BUSHING ADAPTER (SOLID BRASS) • 20-25% CONCENTRATION OF DIAMOND GRAIN • 13,700 RPM MAXIMUM 	
4-1/2" SEGMENTED DIAMOND CUTTING WHEEL		
Part # DCS45 List \$17.36	<ul style="list-style-type: none"> • DRY TYPE • DIAMETER: 4-1/2" ± 0.70MM • TEETH THICKNESS: 0.08" (-0.00/+0.20MM) • 65MN BODY • 7/8" ROUND ARBOR W/ 20MM & 5/8" BUSHING ADAPTER (SOLID BRASS) • 20-25% CONCENTRATION OF DIAMOND GRAIN • 13,300 RPM MAXIMUM 	
7" SEGMENTED DIAMOND CUTTING WHEEL		
Part # DCS70 List \$39.58	<ul style="list-style-type: none"> • DRY TYPE • DIAMETER: 7" ± 0.70MM • TEETH THICKNESS: 0.08" (-0.00/+0.20MM) • 65MN BODY • 7/8" ROUND ARBOR W/ 20MM & 5/8" BUSHING ADAPTER (SOLID BRASS) • 20-25% CONCENTRATION OF DIAMOND GRAIN • 8,400 RPM MAXIMUM 	
12" SEGMENTED DIAMOND CUTTING WHEEL		
Part # DCS120 List \$76.40	<ul style="list-style-type: none"> • DRY TYPE • DIAMETER: 12" • TEETH THICKNESS: 0.1" (-0.05/+0.20MM) • TEETH (HIGH): 0.256" (-0.20/+0.70mm) • 65MN BODY • 1" ROUND ARBOR W/ 20MM & 7/8" BUSHING ADAPTER (SOLID BRASS) • 20-25% CONCENTRATION OF DIAMOND GRAIN • 5,000 RPM MAXIMUM 	
14" SEGMENTED DIAMOND CUTTING WHEEL		
Part # DCS140 List \$103.32	<ul style="list-style-type: none"> • DRY TYPE • DIAMETER: 14" • TEETH THICKNESS: 0.12" (-0.05/+0.20MM) • TEETH (HIGH): 0.315" (-0.20/+0.70mm) • 65MN BODY • 1" ROUND ARBOR W/ 20MM & 7/8" BUSHING ADAPTER (SOLID BRASS) • 20-25% CONCENTRATION OF DIAMOND GRAIN • 4,300 RPM MAXIMUM 	

Phillips

PHILLIPS POINT #	SHEET METAL SCREWS	WOOD SCREWS		MACHINE SCREWS		
	FLAT, ROUND, OVAL STOVE BINDING	FLAT, OVAL	ROUND	FLAT, OVAL BINDING	ROUND, FILLISTER	TRUSS, BRAZIER BUTTON
0	0, 1	0, 1	0, 1	0, 1	0, 1	0, 1
1	2, 3, 4	2, 3, 4	2, 3, 4	2, 3, 4	2, 3, 4	2, 3, 4, 5
2	5, 6, 7, 8, 10	5, 6, 7, 8, 9	5, 6, 7, 8, 9, 10	5, 6, 8, 10	5, 6, 8, 10	6, 8, 10
3	12, 14	10, 12, 14, 16	12, 14, 16	12, 1/4"	12, 1/4", 5/16"	12, 1/4"

Slotted

SLOTTED POINT #	SCREW SIZE	SLOT SCREW WIDTH		THREAD DIA.	MAXIMUM HEAD DIAMETER					
		MIN.	MAX.		FLAT or OVAL HEAD	ROUND HEAD	FILLISTER HEAD	BINDING HEAD	PAN HEAD	TRUSS HEAD
4-5	3	.027	.035	.099	.199	.187	.161	.208	.193	.226
4-5	4	.031	.039	.112	.225	.211	.183	.235	.219	.257
6-8	5	.035	.043	.125	.252	.236	.205	.263	.245	.289
8-10	6	.039	.048	.138	.279	.260	.226	.290	.270	.321
10-12	8	.045	.054	.164	.332	.309	.270	.344	.322	.384

Square

SQUARE POINT #	TAPPING SCREWS	WOOD SCREWS	MACHINE SCREWS
0	3, 4	3, 4	3, 4
1	5, 6, 7	5, 6, 7	5, 6
2	8, 10	8, 9, 10	8, 10
3	12, 14	12, 14	12, 14

Star FOR TORX® SCREWS.

SCREW SIZE	THREAD DIA.	INTERNAL TORX WASHER HEAD	PAN HEAD	FLAT HEAD	HEX HEAD	TRUSS HEAD	FILLISTER HEAD	OVAL HEAD	SOCKET HEAD CAP	SOCKET SET SCREW
2	.086	T7	T7	T6						
3	.099	T8	T8	T7						
4	.112	T9	T9	T8	T9		T9		T10	T6
5	.125	T10	T10	T9	T10		T10	T10	T10	T7
6	.138	T15	T15	T10	T15	T10	T15	T15	T15	T7
8	.164	T20	T20	T15	T20	T15	T20	T20	T25	T8
10	.190	T25	T25	T20	T25	T20	T25	T25	T27	T10
12	.216	T27	T27	T25	T27	T25	T27	T27	T27	T10
1/4"	.250	T30	T30	T27	T30	T27	T30	T30	T30	T20
5/16"	.312			T40	T40	T40	T340	T40	T45	T27
3/8"	.375		T45	T40	T45	T45	T45	T45	T50	T30
7/16"	.437		T50	T50		T45	T50	T50	T55	T40
1/2"	.500		T55	T50		T50	T55	T50	T55	T45

PHILLIPS®, POZIDRIV®, & TRI-WING® are Registered Trade Marks of PHILLIPS SCREW Co.
 TORX® is a Registered Trade Mark of Camcar Div. of Textron.



possibilities



specialized fastening tools

All Screw Driver Bits:
◆ S2 Modified Steel
◆ Rc. 58-62 Heat Treat
◆ German Grade Steel

ISO 9000 factories



Phillips® Insert Bits - 1/4" Hex Shank

Part #	Size	OAL	Type	Qty.	List
T3-025-00	#0 X 1"		PHILLIPS INSERT	25	\$0.75
T3-025-01	#1 X 1"		PHILLIPS INSERT	25	\$0.50
T3-025-02	#2 X 1"		PHILLIPS INSERT	25	\$0.45
T3-025-03	#3 X 1"		PHILLIPS INSERT	25	\$0.45



Reduced Body

Phillips® Drywall Bits - 1/4" Hex Shank

Part #	Size	OAL	Type	Qty.	List
T3-025-1W	#1 X 1"		PHILLIPS DRYWALL	25	\$0.50
T3-025-2W	#2 X 1"		PHILLIPS DRYWALL	25	\$0.50



Phillips® Insert Bits - 5/16" Hex Shank

Part #	Size	OAL	Type	Qty.	List
T3-032-01	#1 X 1-1/4"		PHILLIPS INSERT	10	\$0.95
T3-032-02	#2 X 1-1/4"		PHILLIPS INSERT	10	\$0.95
T3-032-03	#3 X 1-1/4"		PHILLIPS INSERT	10	\$0.95



Phillips® Stopper - 1/4" Hex Shank

Part #	Size	OAL	Type	Qty.	List
SP-025-2P	#2 X 1"		PHILLIPS STOPPER	10	\$1.75



Phillips® ACR® Insert Bits - 1/4" Hex

Part #	Size	OAL	Type	Qty.	List
ACR-025-01	#1 X 1"		PHILLIPS ACR INSERT	25	\$0.55
ACR-025-02	#2 X 1"		PHILLIPS ACR INSERT	25	\$0.55
ACR-025-03	#3 X 1"		PHILLIPS ACR INSERT	25	\$0.55



Phillips® Power Bits - 1/4" Hex Shank

Part #	Size	OAL	Type	Qty.	List
T3-050-01	#1 X 2"		PHILLIPS POWER	25	\$0.75
T3-070-01	#1 X 2-3/4"		PHILLIPS POWER	25	\$1.25
T3-075-01	#1 X 3"		PHILLIPS POWER	25	\$1.35
T3-090-01	#1 X 3-1/2"		PHILLIPS POWER	25	\$1.55
T3-100-01	#1 X 4"		PHILLIPS POWER	25	\$1.85
T3-125-01	#1 X 5"		PHILLIPS POWER	25	\$2.55
T3-150-01	#1 X 6"		PHILLIPS POWER	25	\$3.25
T3-050-02	#2 X 2"		PHILLIPS POWER	25	\$0.75
T3-070-02	#2 X 2-3/4"		PHILLIPS POWER	25	\$1.25
T3-075-02	#2 X 3"		PHILLIPS POWER	25	\$1.35
T3-090-02	#2 X 3-1/2"		PHILLIPS POWER	25	\$1.55
T3-100-02	#2 X 4"		PHILLIPS POWER	25	\$1.85
T3-125-02	#2 X 5"		PHILLIPS POWER	25	\$2.55
T3-150-02	#2 X 6"		PHILLIPS POWER	25	\$3.25
T3-050-03	#3 X 2"		PHILLIPS POWER	25	\$0.75
T3-070-03	#3 X 2-3/4"		PHILLIPS POWER	25	\$1.25
T3-075-03	#3 X 3"		PHILLIPS POWER	25	\$1.35
T3-090-03	#3 X 3-1/2"		PHILLIPS POWER	25	\$1.55
T3-100-03	#3 X 4"		PHILLIPS POWER	25	\$1.85
T3-125-03	#3 X 5"		PHILLIPS POWER	25	\$2.55
T3-150-03	#3 X 6"		PHILLIPS POWER	25	\$3.25



Reduced Body

Phillips® Drywall Bits

Part #	Size	OAL	Type	Qty.	List
T3-050-2W	#2 X 2"		PHILLIPS DRYWALL	25	\$0.85
T3-070-2W	#2 X 2-3/4"		PHILLIPS DRYWALL	25	\$1.35
T3-090-2W	#2 X 3-1/2"		PHILLIPS DRYWALL	25	\$2.15



Phillips® ACR® Power Bits - 1/4" Hex

Part #	Size	OAL	Type	Qty.	List
ACR-050-01	#1 X 2"		PHILLIPS ACR POWER	25	\$0.95
ACR-050-02	#2 X 2"		PHILLIPS ACR POWER	25	\$0.95
ACR-050-03	#3 X 2"		PHILLIPS ACR POWER	25	\$0.95

MAIN OFFICE
 INTERNATIONAL TOOL MANUFACTURING
 71-08 51ST. AVENUE, WOODSIDE, NY 11377
 (718) 446-0711 - (800) 247-5696 - FAX (718) 899-6553



INTERNATIONAL TOOL MANUFACTURING
 675-E-PROGRESS CENTER AVE., LAWRENCEVILLE, GA 30043
 (770) 962-5454 - (800) 229-1776 - FAX (770) 962-5869



For Torx® Screws

Star Insert Bits - 1/4" Hex Shank

Part #	Size	OAL	Type	Qty.	List
TX-025-06	T6	X 1"	STAR INSERT	25	\$0.65
TX-025-07	T7	X 1"	STAR INSERT	25	\$0.65
TX-025-08	T8	X 1"	STAR INSERT	25	\$0.65
TX-025-09	T9	X 1"	STAR INSERT	25	\$0.65
TX-025-10	T10	X 1"	STAR INSERT	25	\$0.65
TX-025-15	T15	X 1"	STAR INSERT	25	\$0.65
TX-025-20	T20	X 1"	STAR INSERT	25	\$0.65
TX-025-25	T25	X 1"	STAR INSERT	25	\$0.65
TX-025-27	T27	X 1"	STAR INSERT	25	\$0.65
TX-025-30	T30	X 1"	STAR INSERT	25	\$0.65
TX-025-40	T40	X 1"	STAR INSERT	25	\$0.65



Square Insert Bits - 1/4" Hex Shank

Part #	Size	OAL	Type	Qty.	List
T3-R25-00	#0	X 1"	SQUARE INSERT	25	\$0.65
T3-R25-01	#1	X 1"	SQUARE INSERT	25	\$0.58
T3-R25-02	#2	X 1"	SQUARE INSERT	25	\$0.58
T3-R25-03	#3	X 1"	SQUARE INSERT	25	\$0.58



For Torx® Screws

Star Insert Bits - 5/16" Hex Shank

Part #	Size	OAL	Type	Qty.	List
TX-032-30	T30	X 1-1/4"	STAR INSERT	10	\$1.55
TX-032-40	T40	X 1-1/4"	STAR INSERT	10	\$1.55
TX-032-45	T45	X 1-1/4"	STAR INSERT	10	\$1.55
TX-032-50	T50	X 1-1/4"	STAR INSERT	10	\$1.55
TX-032-55	T55	X 1-1/4"	STAR INSERT	10	\$1.55



Square Power Bits - 1/4" Hex Shank

Part #	Size	OAL	Type	Qty.	List
T3-R50-01	#1	X 2"	SQUARE POWER	25	\$1.10
T3-R70-01	#1	X 2-3/4"	SQUARE POWER	25	\$1.45
T3-R75-01	#1	X 3"	SQUARE POWER	25	\$1.75
T3-R90-01	#1	X 3-1/2"	SQUARE POWER	25	\$1.95
T3-R10-01	#1	X 4"	SQUARE POWER	25	\$2.15
T3-R12-01	#1	X 5"	SQUARE POWER	25	\$2.75
T3-R15-01	#1	X 6"	SQUARE POWER	25	\$3.75
T3-R50-02	#2	X 2"	SQUARE POWER	25	\$1.10
T3-R70-02	#2	X 2-3/4"	SQUARE POWER	25	\$1.45
T3-R75-02	#2	X 3"	SQUARE POWER	25	\$1.75
T3-R90-02	#2	X 3-1/2"	SQUARE POWER	25	\$1.95
T3-R10-02	#2	X 4"	SQUARE POWER	25	\$2.15
T3-R12-02	#2	X 5"	SQUARE POWER	25	\$2.75
T3-R15-02	#2	X 6"	SQUARE POWER	25	\$3.75
T3-R50-03	#3	X 2"	SQUARE POWER	25	\$1.10
T3-R70-03	#3	X 2-3/4"	SQUARE POWER	25	\$1.45
T3-R75-03	#3	X 3"	SQUARE POWER	25	\$1.75
T3-R90-03	#3	X 3-1/2"	SQUARE POWER	25	\$1.95
T3-R10-03	#3	X 4"	SQUARE POWER	25	\$2.15
T3-R12-03	#3	X 5"	SQUARE POWER	25	\$2.75
T3-R15-03	#3	X 6"	SQUARE POWER	25	\$3.75



For Torx® Screws

Star Power Bits - 1/4" Hex Shank

Part #	Size	OAL	Type	Qty.	List
TX-050-10	T10	X 2"	STAR POWER	25	\$0.85
TX-050-15	T15	X 2"	STAR POWER	25	\$0.85
TX-050-20	T20	X 2"	STAR POWER	25	\$0.85
TX-050-25	T25	X 2"	STAR POWER	25	\$0.85
TX-050-27	T27	X 2"	STAR POWER	25	\$0.85
TX-050-30	T30	X 2"	STAR POWER	25	\$0.85
TX-050-40	T40	X 2"	STAR POWER	25	\$0.85

MAIN OFFICE
INTERNATIONAL TOOL MANUFACTURING
71-08 51ST. AVENUE, WOODSIDE, NY 11377
(718) 446-0711 - (800) 247-5696 - FAX (718) 899-6553



INTERNATIONAL TOOL MANUFACTURING
675-E-PROGRESS CENTER AVE., LAWRENCEVILLE, GA 30043
(770) 962-5454 - (800) 229-1776 - FAX (770) 962-5869



Poizidriv® Insert Bits - 1/4" Hex Shank

Part #	Size	OAL	Type	Qty.	List
PZ-025-01	#1 X 1"		POSIDRIV INSERT	25	\$0.65
PZ-025-02	#2 X 1"		POSIDRIV INSERT	25	\$0.65
PZ-025-03	#3 X 1"		POSIDRIV INSERT	25	\$0.65



Poizidriv® Power Bits - 1/4" Hex Shank

Part #	Size	OAL	Type	Qty.	List
PZ-050-01	#1 X 2"		POSIDRIV POWER	25	\$1.10
PZ-050-02	#2 X 2"		POSIDRIV POWER	25	\$1.10
PZ-075-02	#2 X 3"		POSIDRIV POWER	25	\$1.35
PZ-050-03	#3 X 2"		POSIDRIV POWER	25	\$1.10



Slotted Insert Bits - 1/4" Hex Shank

Part #	Size	OAL	Type	Qty.	List
ST-025-04	#4-5 X 1"		SLOTTED INSERT	25	\$0.56
ST-025-08	#6-8 X 1"		SLOTTED INSERT	25	\$0.56
ST-025-10	#8-10 X 1"		SLOTTED INSERT	25	\$0.56
ST-025-12	#10-12 X 1"		SLOTTED INSERT	25	\$0.56



Slotted Power Bits - 1/4" Hex Shank

Part #	Size	OAL	Type	Qty.	List
ST-050-04	#4-5 X 2"		SLOTTED POWER	25	\$0.98
ST-050-08	#6-8 X 2"		SLOTTED POWER	25	\$0.98
ST-050-10	#8-10 X 2"		SLOTTED POWER	25	\$0.98
ST-070-10	#8-10 X 3"		SLOTTED POWER	25	\$1.48
ST-090-10	#8-10 X 3-1/2"		SLOTTED POWER	25	\$1.65
ST-101-10	#8-10 X 4"		SLOTTED POWER	25	\$1.95
ST-150-10	#8-10 X 6"		SLOTTED POWER	25	\$3.35
ST-050-12	#10-12 X 2"		SLOTTED POWER	25	\$0.98



Hex Insert Bits - 1/4" Hex Shank

Part #	Size	OAL	Type	Qty.	List
HE-25-564	5/64" X 1"		HEX INSERT	25	\$0.80
HE-25-332	3/32" X 1"		HEX INSERT	25	\$0.80
HE-25-764	7/64" X 1"		HEX INSERT	25	\$0.80
HE-25-864	1/8" X 1"		HEX INSERT	25	\$0.80
HE-25-532	5/32" X 1"		HEX INSERT	25	\$0.80
HE-25-316	3/16" X 1"		HEX INSERT	25	\$0.80



Hex Insert Bits - 5/16" Hex Shank

Part #	Size	OAL	Type	Qty.	List
HE-32-316	3/16" X 1-1/4"		HEX INSERT	25	\$1.25
HE-32-732	7/32" X 1-1/4"		HEX INSERT	25	\$1.25
HE-32-014	1/4" X 1-1/4"		HEX INSERT	25	\$1.25



Metric Hex Insert Bits - 1/4" Hex

Part #	Size	OAL	Type	Qty.	List
HE-25-020	2.0 mm X 1"		HEX INSERT	25	\$2.81
HE-25-025	2.5 mm X 1"		HEX INSERT	25	\$2.81
HE-25-030	3.0 mm X 1"		HEX INSERT	25	\$2.81
HE-25-040	4.0 mm X 1"		HEX INSERT	25	\$2.81
HE-25-050	5.0 mm X 1"		HEX INSERT	25	\$2.81
HE-25-060	6.0 mm X 1"		HEX INSERT	25	\$2.81



Double End Bits - 1/4" Hex Shank

Part #	Size	Qty.	List
DW-050-22	#2 PHILLIPS / #2 PHILLIPS	25	\$1.15
DW-050-26	#2 PHILLIPS / #6-8 SLOTTED	25	\$1.15
DW-050-28	#2 PHILLIPS / #8-10 SLOTTED	25	\$1.15

MAIN OFFICE
INTERNATIONAL TOOL MANUFACTURING
71-08 51ST. AVENUE, WOODSIDE, NY 11377
(718) 446-0711 - (800) 247-5696 - FAX (718) 899-6553



INTERNATIONAL TOOL MANUFACTURING
675-E-PROGRESS CENTER AVE., LAWRENCEVILLE, GA 30043
(770) 962-5454 - (800) 229-1776 - FAX (770) 962-5869



Spanner Insert Bits - 1/4" Hex Shank

Part #	Size	OAL	Type	Qty.	List
SP-025-06	#6 X 1"		SPANNER	25	\$1.75
SP-025-08	#8 X 1"		SPANNER	25	\$1.75
SP-025-10	#10 X 1"		SPANNER	25	\$1.75
SP-025-12	#12 X 1"		SPANNER	25	\$1.75
SP-025-14	#14 X 1"		SPANNER	25	\$1.75



Hex Tamper Insert Bits - 1/4" Hex

Part #	Size	OAL	Type	Qty.	List
TH-25-332	3/32" X 1"		HEX TAMPER	25	\$1.55
TH-25-018	1/8" X 1"		HEX TAMPER	25	\$1.55
TH-25-964	9/64" X 1"		HEX TAMPER	25	\$1.55
TH-25-532	5/32" X 1"		HEX TAMPER	25	\$1.55
TH-25-316	3/16" X 1"		HEX TAMPER	25	\$1.55
TH-25-732	7/32" X 1"		HEX TAMPER	25	\$1.55
TH-25-014	1/4" X 1"		HEX TAMPER	25	\$1.55
TH-25-516	5/16" X 1"		HEX TAMPER	25	\$1.55



For TAMPER RESISTANT Torx® Screws

Star Tamper Insert Bits - 1/4" Hex

Part #	Size	OAL	Type	Qty.	List
TT-025-08	T8 X 1"		STAR TAMPER	25	\$1.45
TT-025-09	T9 X 1"		STAR TAMPER	25	\$1.45
TT-025-10	T10 X 1"		STAR TAMPER	25	\$1.45
TT-025-15	T15 X 1"		STAR TAMPER	25	\$1.45
TT-025-20	T20 X 1"		STAR TAMPER	25	\$1.45
TT-025-25	T25 X 1"		STAR TAMPER	25	\$1.45
TT-025-27	T27 X 1"		STAR TAMPER	25	\$1.45
TT-025-30	T30 X 1"		STAR TAMPER	25	\$1.45
TT-025-40	T40 X 1"		STAR TAMPER	25	\$1.45



Tri-Wing Tamper Insert Bits - 1/4" Hex

Part #	Size	OAL	Type	Qty.	List
TRI-25-01	#1 X 1"		TRI-WING	10	\$1.45
TRI-25-02	#2 X 1"		TRI-WING	10	\$1.45
TRI-25-03	#3 X 1"		TRI-WING	10	\$1.45



For TAMPER RESISTANT Torx® Screws

Star Tamper Insert Bits - 5/16" Hex

Part #	Size	OAL	Type	Qty.	List
TT-032-45	T45 X 1-1/4"		STAR TAMPER	10	\$2.35
TT-032-50	T50 X 1-1/4"		STAR TAMPER	10	\$2.35
TT-032-55	T55 X 1-1/4"		STAR TAMPER	10	\$2.35



Phillips® Tamper Insert Bits - 1/4" Hex

Part #	Size	OAL	Type	Qty.	List
TP-025-02	#2 X 1"		PHILLIPS TAMPER	10	\$2.75
TP-025-03	#3 X 1"		PHILLIPS TAMPER	10	\$2.75

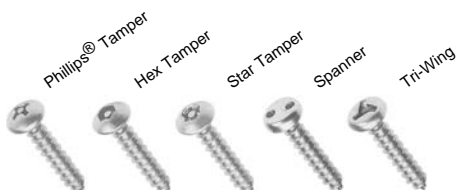

◆ For all 1/4" Hex Insert Bits

Bit Holders - Stainless Steel - Magnetic



Part #	OAL	Body Dia.	Retaining Ring	Description	List
BH-020-RC	1-3/4"	7/16"	NO	2PC. CONSTRUCTION	\$5.33



Part #	OAL	Body Dia.	Retaining Ring	Description	List
BH-040-RC	1-13/16"	7/16"	YES	1PC. CONSTRUCTION	\$5.65



Part #	OAL	Body Dia.	Retaining Ring	Description	List
BH-060-RC	2-5/8"	7/16"	YES	1PC. CONSTRUCTION	\$4.75

BH-060-40 made of Chrome Vanadium.



Part #	OAL	Body Dia.	Retaining Ring	Description	List
BH-060-40	2-5/8"	3/8"	NO	2PC. CONSTRUCTION	\$3.21



Part #	OAL	Body Dia.	Retaining Ring	Description	List
BH-075-14	3"	7/16"	NO	2PC. CONSTRUCTION	\$4.77



Part #	OAL	Body Dia.	Retaining Ring	Description	List
BH-075-14R	3"	7/16"	YES	2PC. CONSTRUCTION	\$5.00



Part #	OAL	Body Dia.	Retaining Ring	Description	List
BH-075-RC	3"	7/16"	YES	1PC. CONSTRUCTION	\$5.35



Part #	OAL	Body Dia.	Retaining Ring	Description	List
BH-100-TR	3"	7/16"	THREADED	1PC. CONSTRUCTION	\$10.80



Part #	OAL	Body Dia.	Retaining Ring	Description	List
BH-100-RC	4"	7/16"	YES	1PC. CONSTRUCTION	\$8.83



Part #	OAL	Body Dia.	Retaining Ring	Description	List
BH-150-RC	6"	7/16"	YES	1PC. CONSTRUCTION	\$16.93

Nut Setters - Magnetic

Part #	Hex Head Size	X	OAL	Type	Qty.	List
NS-042-16	1/4"	X	1-3/4"	MAG. NUT SETTER	10	\$2.40
NS-053-16	1/4"	X	2-1/8"	MAG. NUT SETTER	10	\$2.75
NS-065-16	1/4"	X	2-9/16"	MAG. NUT SETTER	10	\$2.89
NS-075-16	1/4"	X	4"	MAG. NUT SETTER	5	\$6.20
NS-085-16	1/4"	X	6"	MAG. NUT SETTER	5	\$8.45
NS-042-20	5/16"	X	1-3/4"	MAG. NUT SETTER	10	\$2.55
NS-053-20	5/16"	X	2-1/8"	MAG. NUT SETTER	10	\$3.05
NS-065-20	5/16"	X	2-9/16"	MAG. NUT SETTER	10	\$3.25
NS-075-20	5/16"	X	4"	MAG. NUT SETTER	5	\$7.20
NS-085-20	5/16"	X	6"	MAG. NUT SETTER	5	\$10.89
NS-042-24	3/8"	X	1-3/4"	MAG. NUT SETTER	10	\$3.25
NS-053-24	3/8"	X	2-1/8"	MAG. NUT SETTER	10	\$4.25
NS-065-24	3/8"	X	2-9/16"	MAG. NUT SETTER	10	\$4.65
NS-075-24	3/8"	X	4"	MAG. NUT SETTER	5	\$8.26
NS-085-24	3/8"	X	6"	MAG. NUT SETTER	5	\$13.78
NS-042-28	7/16"	X	1-3/4"	MAG. NUT SETTER	5	\$6.75
NS-053-28	7/16"	X	2-1/8"	MAG. NUT SETTER	5	\$7.56
NS-065-28	7/16"	X	2-9/16"	MAG. NUT SETTER	5	\$7.99
NS-042-32	1/2"	X	1-3/4"	MAG. NUT SETTER	5	\$7.45
NS-065-32	1/2"	X	2-9/16"	MAG. NUT SETTER	5	\$8.65

- ◆ 1pc Construction
- ◆ 1/4" Hex Power Shank



1-3/4" Long



2-1/8" Long



2-9/16" Long



4" Long

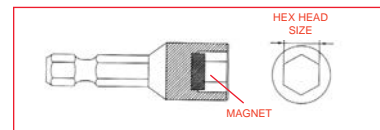

Cr-V 6150 Rc. 50-54

Lag Driver / Ceiling Tile Hanger Driver

Part #	Size	Type	Qty.	List
CE-075-14SL	7/16" X 2-3/16"	LAG DRIVER WITH SLEEVE	10	\$3.95



◆ For all 1/4" Hex Insert Bits



Pull back system locks in bits.



Sleeve extends up to 8" (on 5" length sleeve guide) to hold screw while fastening.

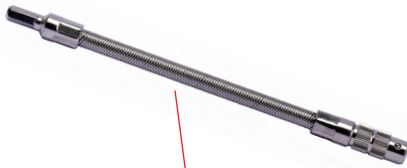

Flexible shaft can bend up to 90° for those hard to reach areas.



Chucks have a quick insert / quick spring out system for easy bit changing. Locks in bits. Use with 2"+ POWER bits only!!!



Use with any 1" bit tips. Adjustable depth prevents over-driving screws into material. Magnetic.

Bit Holders - Special Application - Magnetic

Part #	OAL	Body Dia.	Retaining Ring	Description	List
BH-050-LK	2"	9/16"	YES / LOCK	SNAP LOCK HOLDER	\$7.18
BH-075-LK	3"	9/16"	YES / LOCK	SNAP LOCK HOLDER	\$9.63

Part #	OAL	Body Dia.	Retaining Ring	Description	List
BH-075-SL	3"	7/16"	NO	SLEEVE GUIDE HOLDER	\$5.72
BH-125-SL	5"	7/16"	NO	SLEEVE GUIDE HOLDER	\$6.05

Part #	OAL	Body Dia.	Retaining Ring	Description	List
FX-075-01	7-1/4"	1/2"	YES / BALL	FLEXIBLE BIT HOLDER	\$13.75

Part #	OAL	Body Dia.	Retaining Ring	Description	List
QUI0001	1-3/4"	13/16"	LOCK	METAL/SPRING OUT	\$6.25

Part #	OAL	Body Dia.	Retaining Ring	Description	List
DC-075-01	3"	9/16"	LOCK	POWER STOPPER	\$9.95

MAIN OFFICE
 INTERNATIONAL TOOL MANUFACTURING
 71-08 51ST. AVENUE, WOODSIDE, NY 11377
 (718) 446-0711 - (800) 247-5696 - FAX (718) 899-6553



INTERNATIONAL TOOL MANUFACTURING
 675-E-PROGRESS CENTER AVE., LAWRENCEVILLE, GA 30043
 (770) 962-5454 - (800) 229-1776 - FAX (770) 962-5869



**STAINLESS STEEL
 SHAFT**



**1/4" Drive & 5/16" Drive Magnetic Screw Drivers
 With Insert Bit Storage Handles. BITS NOT INCLUDED.**

Part #	Drive	Description	List
HH-08-001	1/4"	8" MAGNETIC STORAGE HANDLE	\$9.85
HH-08-002	5/16"	8" MAGNETIC STORAGE HANDLE	\$11.25



**1/4" Drive Magnetic Screw Drivers
 With 5 Insert Bits In Storage Handle**

Part #	Content					List
HH-08-100	#4-5 SLOTTED	#8-10 SLOTTED	#1 PHILLIPS	#2 PHILLIPS	#3 PHILLIPS	\$14.25
HH-08-200	#4-5 SLOTTED	#8-10 SLOTTED	#1 PHILLIPS	#2 PHILLIPS	#15 STAR	\$14.25
HH-08-300	#4-5 SLOTTED	#8-10 SLOTTED	#1 PHILLIPS	#2 PHILLIPS	#2 SQUARE	\$14.25
HH-08-400	T15 STAR	T20 STAR	T25 STAR	T27 STAR	T30 STAR	\$14.25
HH-08-500	T15 STAR PIN	T20 STAR PIN	T25 STAR PIN	T27 STAR PIN	T30 STAR PIN	\$15.75
HH-08-600	#6 SPANNER	#8 SPANNER	#10 SPANNER	#12 SPANNER	#2 PHILLIPS	\$15.75

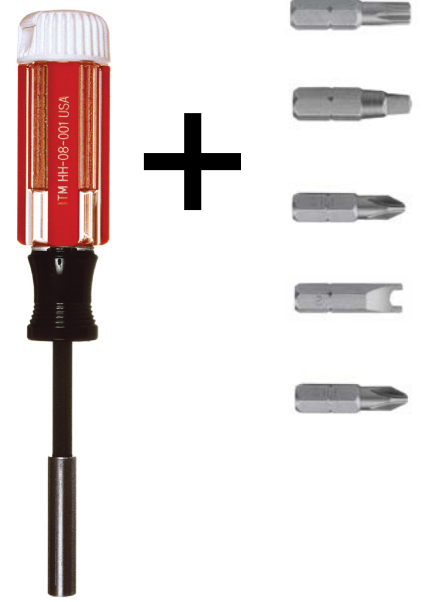

MAIN OFFICE
 INTERNATIONAL TOOL MANUFACTURING
 71-08 51ST. AVENUE, WOODSIDE, NY 11377
 (718) 446-0711 - (800) 247-5696 - FAX (718) 899-6553



INTERNATIONAL TOOL MANUFACTURING
 675-E-PROGRESS CENTER AVE., LAWRENCEVILLE, GA 30043
 (770) 962-5454 - (800) 229-1776 - FAX (770) 962-5869



30 Pc. Screw Driver Insert Set - STANDARD

Part #	Description	List
ST-100-30	30 PIECE INSERT SET WITH CASE & HANDLE	\$38.00
	#1, #2, #3 PHILLIPS® #0, #1, #2, #3 SQUARE	
	3-4, 4-5, 6-8, 8-10 SLOTTED 5/64", 3/32", 7/64", 1/8" -	
	#1, #2, #3 POSIDRIV® 9/64" HEX	
	1" LONG SOCKET ADAPTER T10, T15, T20, T25, T27, T30 -	
	3" LONG BIT HOLDER T40 STAR	



30 Pc. Screw Driver Insert Set - TAMPER PROOF

Part #	Description	List
TR-100-30	30 PIECE TAMPER RESISTANT INSERT SET WITH CASE & HANDLE	\$47.50
	#6, #8, #10 SPANNER® 3/32", 1/8", 9/64", 5/32" -	
	#1, #2, #3 POZIDRIV® 3/16", 7/32", 1/4", 5/16" HEX	
	#1, #2, #3 TRI-WING	
	1" LONG SOCKET ADAPTER T8, T9, T10, T15, T20, T25 -	
	3" LONG BIT HOLDER T27, T30, T40 STAR	



10 Pc. Dial-A-Drill Insert Set

Part #	Description	List
ST-100-08	10 PIECE INSERT SET	\$9.50
	#1, #2, #3 PHILLIPS #1, #2, #3 SQUARE	
	#6-8, #8-10, #10-12 SLOTTED 2-5/8" BIT HOLDER	



SOLD IN 12 PIECE
 DISPLAY BOX ONLY



6-IN-1 Combination Screw Driver

Part #	Description	List
ST-100-20	6-IN-1 SCREW DRIVER	\$7.25
	#1, #2, PHILLIPS 1/4" NUT SETTER	
	#5, #8-10, SLOTTED 5/16" NUT SETTER	

MAIN OFFICE
 INTERNATIONAL TOOL MANUFACTURING
 71-08 51ST. AVENUE, WOODSIDE, NY 11377
 (718) 446-0711 - (800) 247-5696 - FAX (718) 899-6553



INTERNATIONAL TOOL MANUFACTURING
 675-E-PROGRESS CENTER AVE., LAWRENCEVILLE, GA 30043
 (770) 962-5454 - (800) 229-1776 - FAX (770) 962-5869



MEGAPRO+



Part #	Description	List
MEGAPRO151	15-IN-1 MEGAPRO SCREW DRIVER #0 - #3 PHILLIPS #10 - #15 STAR #1 - #2 PHILLIPS #20 - #25 STAR #0 - #3 SQUARE #4 - #6 SLOTTED #1 - #2 SQUARE	\$38.86



FREE DISPLAY!!!
 WITH FIRST TIME PURCHASE OF 20 DRIVERS. \$25 VALUE.

Part #	Description	List
MEGATAM151	15-IN-1 TAMPERPROOF SCREW DRIVER #6 - #8 SPANNER #10 - #15 STAR PIN #10 - #12 SPANNER #20 - #25 STAR PIN 1/8" - 9/64" HEX PIN #27 - #30 STAR PIN 5/32" - 3/16" HEX PIN	\$49.50



Tamper Proof Tamper Proof Driver sold Individually Pouched.

Part #	Description	List
470001	#0 - #3 PHILLIPS®	\$2.50
470002	#1 - #2 PHILLIPS®	\$2.50
470003	#0 - #3 SQUARE	\$2.50
470004	#1 - #2 SQUARE	\$2.50
470005	#10 - #15 STAR	\$2.50
470006	#20 - #25 STAR	\$2.50
470009	#27 - #30 STAR (SPECIAL SIZE)	\$2.50
470007	#4 - #6 SLOTTED	\$2.50
690001	#6 - #8 SPANNER	\$2.75
690002	#10 - #12 SPANNER	\$2.75
690003	1/8" - 9/64" HEX PIN	\$2.75
690004	5/32" - 3/16" HEX PIN	\$2.75
690005	#10 - #15 STAR PIN	\$2.75
690006	#20 - #25 STAR PIN	\$2.75
690007	#27 - #30 STAR PIN	\$2.75

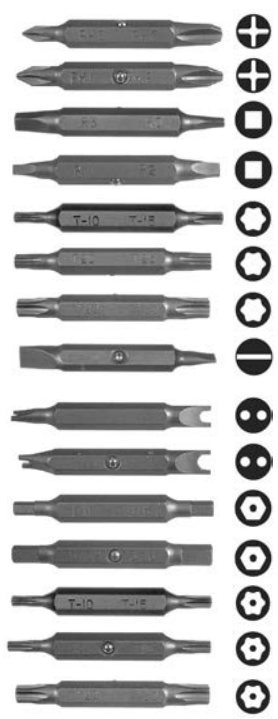

Replacement bits for the Megapro & Megapro Tamper Proof are sold individually.

PHILLIPS® IS A REGISTERED TRADEMARK OF PHILLIPS SCREW Co.

1/4"
DRIVE



1/4" Shank To 1/4" Square Drive

Part #	SHANK HEX SIZE	x	TOTAL LENGTH	x	MALE SQUARE	Description	List
AD-025-14	1/4"	x	1"	x	1/4"	SOCKET EXTENSION	\$1.88
AD-032-14	1/4"	x	1-1/4"	x	1/4"	SOCKET EXTENSION	\$4.22
AD-050-14	1/4"	x	2"	x	1/4"	SOCKET EXTENSION	\$4.25
AD-075-14	1/4"	x	3"	x	1/4"	SOCKET EXTENSION	\$4.66
AD-100-14	1/4"	x	4"	x	1/4"	SOCKET EXTENSION	\$5.90
AD-150-14	1/4"	x	6"	x	1/4"	SOCKET EXTENSION	\$7.42
AD-200-14	1/4"	x	8"	x	1/4"	SOCKET EXTENSION	\$9.09

3/8"
DRIVE



1/4" Shank To 3/8" Square Drive

Part #	SHANK HEX SIZE	x	TOTAL LENGTH	x	MALE SQUARE	Description	List
AD-050-38	1/4"	x	2"	x	3/8"	SOCKET EXTENSION	\$6.01
AD-075-38	1/4"	x	3"	x	3/8"	SOCKET EXTENSION	\$6.45
AD-100-38	1/4"	x	4"	x	3/8"	SOCKET EXTENSION	\$8.95
AD-150-38	1/4"	x	6"	x	3/8"	SOCKET EXTENSION	\$11.00
AD-200-38	1/4"	x	8"	x	3/8"	SOCKET EXTENSION	\$16.25

1/2"
DRIVE



1/4" Shank To 1/2" Square Drive

Part #	SHANK HEX SIZE	x	TOTAL LENGTH	x	MALE SQUARE	Description	List
AD-055-12	1/4"	x	2-1/8"	x	1/2"	SOCKET EXTENSION	\$7.13
AD-075-12	1/4"	x	3"	x	1/2"	SOCKET EXTENSION	\$8.69
AD-150-12	1/4"	x	6"	x	1/2"	SOCKET EXTENSION	\$12.39
AD-200-12	1/4"	x	8"	x	1/2"	SOCKET EXTENSION	\$16.48

1/4" Square Drive Magnetic Impact Sockets

Part #	SQUARE DRIVE	x	(A) LENGTH	x	HEX DRIVE	(B) BODY	(C) NOSE	Description	List
250ST1264	1/4"	x	15/16"	x	3/16"	1/2"	3/8"	MAG. IMPACT SOCKET	\$5.60
250ST1664	1/4"	x	15/16"	x	1/4"	1/2"	7/16"	MAG. IMPACT SOCKET	\$4.69
250ST2064	1/4"	x	15/16"	x	5/16"	1/2"	1/2"	MAG. IMPACT SOCKET	\$5.66
250ST2464	1/4"	x	1"	x	3/8"	5/8"	9/16"	MAG. IMPACT SOCKET	\$5.69
250ST2864	1/4"	x	1"	x	7/16"	11/16"	5/8"	MAG. IMPACT SOCKET	\$7.74
250ST3264	1/4"	x	1"	x	1/2"	3/4"	3/4"	MAG. IMPACT SOCKET	\$9.59

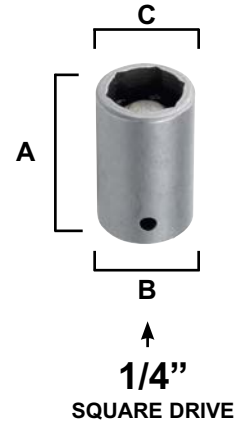

3/8" Square Drive Magnetic Impact Sockets

Part #	SQUARE DRIVE	x	(A) LENGTH	x	HEX DRIVE	(B) BODY	(C) NOSE	Description	List
375ST1664	3/8"	x	1-1/4"	x	1/4"	3/4"	7/16"	MAG. IMPACT SOCKET	\$7.74
375ST2064	3/8"	x	1-1/4"	x	5/16"	3/4"	1/2"	MAG. IMPACT SOCKET	\$7.74
375ST2464	3/8"	x	1-1/4"	x	3/8"	3/4"	9/16"	MAG. IMPACT SOCKET	\$8.65
375ST2864	3/8"	x	1-1/4"	x	7/16"	3/4"	5/8"	MAG. IMPACT SOCKET	\$11.73
375ST3264	3/8"	x	1-1/2"	x	1/2"	15/16"	3/4"	MAG. IMPACT SOCKET	\$11.73

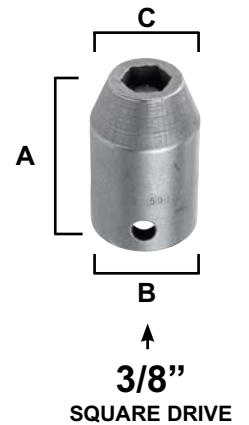

1/2" Square Drive Magnetic Impact Sockets

Part #	SQUARE DRIVE	x	(A) LENGTH	x	HEX DRIVE	(B) BODY	(C) NOSE	Description	List
500ST1664	1/2"	x	1-1/2"	x	1/4"	15/16"	7/16"	MAG. IMPACT SOCKET	\$9.59
500ST2064	1/2"	x	1-1/2"	x	5/16"	15/16"	1/2"	MAG. IMPACT SOCKET	\$9.03
500ST2464	1/2"	x	1-1/2"	x	3/8"	15/16"	9/16"	MAG. IMPACT SOCKET	\$9.24
500ST2864	1/2"	x	1-1/2"	x	7/16"	15/16"	5/8"	MAG. IMPACT SOCKET	\$10.15
500ST3264	1/2"	x	1-1/2"	x	1/2"	15/16"	3/4"	MAG. IMPACT SOCKET	\$10.15

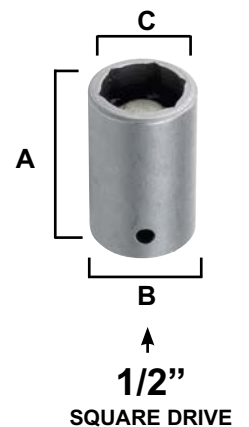

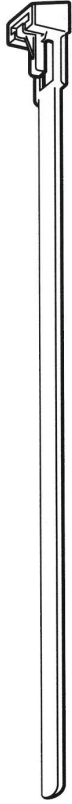

NATURAL NYLON 6.6 CABLE TIES

B U L K	Part #	Length	Tensile Strength	Width	Bundle Diameter	Military Specification	Bulk Qty.	List / 1000
	MS0016	4"	18 lbs.	3/32"	1/16" → 5/8"	MS-3367-4-9	1000	\$15.88
	MS0032	5.5"	40 lbs.	1/8"	1/16" → 1-1/4"	MS-3367-5-9	1000	\$22.52
	MS0050	8"	50 lbs.	1/8"	1/16" → 2-1/8"	MS-3367-4-9	1000	\$30.92
	MS0070	11"	50 lbs.	3/16"	1/16" → 3"	MS-3367-7-9	1000	\$61.65
	MS0108	15"	50 lbs.	3/16"	1/16" → 4"	MS-3367-2-9	500	\$79.48

NATURAL NYLON 6.6 CABLE TIES

FOR PEG BOARD

B A G	Part #	Length	Tensile Strength	Width	Bundle Diameter	Military Specification	Bulk Qty.	List / 100
	MS0016-C	4"	18 lbs.	3/32"	1/16" → 5/8"	MS-3367-4-9	100	\$4.18
	MS0032-C	5.5"	40 lbs.	1/8"	1/16" → 1-1/4"	MS-3367-5-9	100	\$5.22
	MS0050-C	8"	50 lbs.	1/8"	1/16" → 2-1/8"	MS-3367-4-9	100	\$6.32
	MS0070-C	11"	50 lbs.	3/16"	1/16" → 3"	MS-3367-7-9	100	\$13.92
	MS0108-C	15"	50 lbs.	3/16"	1/16" → 4"	MS-3367-2-9	100	\$19.14

NATURAL NYLON 6.6 CABLE TIES - EXTRA HEAVY DUTY

B U L K	Part #	Length	Tensile Strength	Width	Bundle Diameter	Military Specification	Bulk Qty.	List / 100
	XMS0050	8"	120 lbs.	5/16"	3/16" → 2"	-	100	\$17.69
	XMS0070	11"	120 lbs.	5/16"	3/16" → 3"	-	100	\$19.67
	XMS0108	15"	120 lbs.	5/16"	3/16" → 4"	-	100	\$22.74
	XMS0152	24"	175 lbs.	3/8"	3/16" → 7"	-	100	\$41.45
	XMS0225	36"	175 lbs.	3/8"	3/16" → 10"	-	100	\$48.02
XMS0300	48"	175 lbs.	3/8"	3/16" → 12"	-	100	\$71.94	

BLACK WEATHER RESISTANT NYLON CABLE TIES

B U L K	Part #	Length	Tensile Strength	Width	Bundle Diameter	Military Specification	Bulk Qty.	List / 1000
	BWR0016	4"	18 lbs.	3/32"	1/16" → 5/8"	MS-3367-4-0	1000	\$17.94
	BWR0032	5.5"	40 lbs.	1/8"	1/16" → 1-1/4"	MS-3367-5-0	1000	\$26.15
	BWR0050	8"	50 lbs.	1/8"	1/16" → 2-1/8"	MS-3367-4-0	1000	\$34.18
	BWR0070	11"	50 lbs.	3/16"	1/16" → 3"	MS-3367-7-0	1000	\$71.79
	BWR0108	15"	50 lbs.	3/16"	1/16" → 4"	MS-3367-2-0	500	\$110.49

BLACK WEATHER RESISTANT NYLON CABLE TIES

FOR PEG BOARD

B A G	Part #	Length	Tensile Strength	Width	Bundle Diameter	Military Specification	Bulk Qty.	List / 100
	BWR0016-C	4"	18 lbs.	3/32"	1/16" → 5/8"	MS-3367-4-0	100	\$5.02
	BWR0032-C	5.5"	40 lbs.	1/8"	1/16" → 1-1/4"	MS-3367-5-0	100	\$6.26
	BWR0050-C	8"	50 lbs.	1/8"	1/16" → 2-1/8"	MS-3367-4-0	100	\$7.58
	BWR0070-C	11"	50 lbs.	3/16"	1/16" → 3"	MS-3367-7-0	100	\$14.99
	BWR0108-C	15"	50 lbs.	3/16"	1/16" → 4"	MS-3367-2-0	100	\$20.69

BLACK WEATHER RESISTANT NYLON CABLE TIES - EXTRA H.D.

B U L K	Part #	Length	Tensile Strength	Width	Bundle Diameter	Military Specification	Bulk Qty.	List / 100
	XBWR050	8"	120 lbs.	5/16"	3/16" → 2"	-	100	\$17.99
	XBWR070	11"	120 lbs.	5/16"	3/16" → 3"	-	100	\$20.27
	XBWR108	15"	120 lbs.	5/16"	3/16" → 4"	-	100	\$25.72
	XBWR152	24"	175 lbs.	3/8"	3/16" → 7"	-	100	\$45.15
	XBWR225	36"	175 lbs.	3/8"	3/16" → 10"	-	100	\$56.60
XBWR300	48"	175 lbs.	3/8"	3/16" → 12"	-	100	\$85.19	

- ◆ Manufactured of 100% Nylon
- ◆ Non-Corrosive
- ◆ Specification: Type 6.6 Nylon
- ◆ Self-Extinguishing
- ◆ Natural & Weather Resistant Black Operating Temperatures From 40° F (-40° C) to 185° F (85° C).
- ◆ Recognized Under the Components Program of Underwriter Laboratories, Inc.

File # E 57800.





Conical Plastic Anchors



BAG



BOX

Part #	Size	Screw Size	Anchor Type	Color	Qty.	Packaged	List
803CAB004	3/16" X 3/4"	4 - 6	CONICAL	BLUE	60,000	BULK	\$8.50 /M
803CAB006	3/16" X 7/8"	6 - 8	CONICAL	BLUE	40,000	BULK	\$8.50 /M
803CAB008	1/4" X 1"	8 - 10	CONICAL	BLUE	20,000	BULK	\$12.85 /M
803CAB012	5/16" X 1-1/4"	12 - 16	CONICAL	BLUE	12,000	BULK	\$23.80 /M
806CAB006	3/16" X 7/8"	6 - 8	CONICAL	BLUE	1,000	BAG	\$9.75
806CAB008	1/4" X 1"	8 - 10	CONICAL	BLUE	500	BAG	\$8.35
806CAB012	5/16" X 1-1/4"	12 - 16	CONICAL	BLUE	500	BAG	\$14.05
802CAB006	3/16" X 7/8"	6 - 8	CONICAL	BLUE	100	BOX	\$2.10
802CAB008	1/4" X 1"	8 - 10	CONICAL	BLUE	100	BOX	\$2.98
802CAB012	5/16" X 1-1/4"	12 - 16	CONICAL	BLUE	100	BOX	\$5.75



Ribbed Plastic Anchors

- ◆ Internal Ribs for Better Centering of Screw.
- ◆ Locking Lugs Against Pull & Twist.
- ◆ Special Exterior Design Prevents Fall Out in Overhead Holes.
- ◆ Deep Teeth give Maximum Anchoring in Concrete, and Bite Deeply in Drywall or Wood.
- ◆ Unique Expansion Capacity in Soft Material.

Part #	Size	Screw Size	Anchor Type	Color	Qty.	Packaged	List
800RBR006	3/16" X 7/8"	6-8	RIBBED	RED	40,000	BULK	\$15.83 /M
800RBR008	1/4" X 1"	8-12	RIBBED	RED	20,000	BULK	\$22.29 /M
800RBR012	5/16" X 1-1/4"	12 - 16	RIBBED	RED	12,000	BULK	\$49.79 /M
806RBR006	3/16" X 7/8"	6-8	RIBBED	RED	1,000	BAG	\$15.83
806RBR008	1/4" X 1"	8-12	RIBBED	RED	500	BAG	\$13.00
806RBR012	5/16" X 1-1/4"	12 - 16	RIBBED	RED	500	BAG	\$29.05
802RBR006	3/16" X 7/8"	6-8	RIBBED	RED	100	BOX	\$2.50
802RBR008	1/4" X 1"	8-12	RIBBED	RED	100	BOX	\$3.47
802RBR012	5/16" X 1-1/4"	12 - 16	RIBBED	RED	100	BOX	\$6.81



Super Ribbed Plastic Anchors

Ribbed Plastic Anchors can be used in solid or hollow wall with either wood or sheet metal screws.



Extra wings!

Part #	Size	Screw Size	Anchor Type	Color	Qty.	Packaged	List
SA316Y	3/16" X 7/8"	6 - 8	SUPER	YELLOW	40,000	BULK	\$17.99 /M
SA014Y	1/4" X 1-1/4"	8 - 12	SUPER	YELLOW	18,000	BULK	\$28.74 /M
SA516Y	5/16" X 1-1/2"	12 - 16	SUPER	YELLOW	10,000	BULK	\$38.65 /M
BASA316	3/16" X 7/8"	6 - 8	SUPER	YELLOW	1,000	BAG	\$17.99
BASA014	1/4" X 1-1/4"	8 - 12	SUPER	YELLOW	500	BAG	\$13.37
BASA516	5/16" X 1-1/2"	12 - 16	SUPER	YELLOW	500	BAG	\$19.32
BASA316R	3/16" X 7/8"	6 - 8	SUPER	YELLOW	100	BOX	\$2.64
BASA014R	1/4" X 1-1/4"	8 - 12	SUPER	YELLOW	100	BOX	\$3.47
BASA516R	5/16" X 1-1/2"	12 - 16	SUPER	YELLOW	100	BOX	\$6.81



- ◆ High Quality Impact Resistant Clear Box with Separations.
- ◆ 4" Long Slow Spiral Gold Head Black Masonry Bit Matching Anchor Sizes.
- ◆ High Quality Screws Match Anchor Sizes.
- ◆ Same High Quality American Made Anchors as on Pages 111.



RIBBED ANCHOR - RED



CONICAL ANCHOR - BLUE



SUPER ANCHOR - YELLOW



ZAP-IN ANCHOR



HEX HEAD SCREW



COMBO HEAD SCREW

PART #
807AK0006
 100 pcs. - 3/16" Ribbed Anchors
 100 pcs. - #8 Combo Screws
 1 pc. - 3/16" Slow Spiral Masonry
List \$7.45

PART #
807AX0007
 100 pcs. - 1/4" Ribbed Anchors
 100 pcs. - #10 HEX Screws
 1 pc. - 1/4" Slow Spiral Masonry
List \$9.98



PART #
807AK0016
 100 pcs. - 1/4" Ribbed Anchors
 100 pcs. - #10 Combo Screws
 1 pc. - 1/4" Slow Spiral Masonry
List \$8.75

PART #
807AK0009
 50 pcs. - 5/16" Ribbed Anchors
 50 pcs. - #12 Combo Screws
 1 pc. - 5/16" Slow Spiral Masonry
List \$10.51



PART #
807AK0010
 100 pcs. - 3/16" Conical Anchors
 100 pcs. - #8 Combo Screws
 1 pc. - 3/16" Slow Spiral Masonry
List \$6.95

PART #
807AK0011
 100 pcs. - 1/4" Conical Anchors
 100 pcs. - #10 Combo Screws
 1 pc. - 1/4" Slow Spiral Masonry
List \$7.68

PART #
807AK0012
 100 pcs. - 1/4" Conical Anchors
 100 pcs. - #10 HEX Screws
 1 pc. - 1/4" Slow Spiral Masonry
List \$8.91

PART #
807AK0013
 50 pcs. - 5/16" Conical Anchors
 50 pcs. - #12 Combo Screws
 1 pc. - 5/16" Slow Spiral Masonry
List \$10.51



PART #
SUPRAK006
 100 pcs. - 3/16" SUPER Anchors
 100 pcs. - #8 Combo Screws
 1 pc. - 3/16" Slow Spiral Masonry
List \$7.73

PART #
SUPRAK007
 100 pcs. - 1/4" SUPER Anchors
 100 pcs. - #10 x 1/4" HEX Screws
 1 pc. - 1/4" Slow Spiral Masonry
List \$10.05

PART #
SUPRAK008
 100 pcs. - 1/4" SUPER Anchors
 100 pcs. - #10 x 1/4" Combo Screws
 1 pc. - 1/4" Slow Spiral Masonry
List \$9.44

PART #
SUPRAK009
 50 pcs. - 5/16" SUPER Anchors
 50 pcs. - #12 x 1/2" Combo Screws
 1 pc. - 5/16" Slow Spiral Masonry
List \$10.52



PART #
EZN-PACK
 50 pcs. - Nylon Zap-In
 50 pcs. - #8 x 1" Combo Screws
 1 pc. - #2 X 2" Phillips Bit
List \$20.10

PART #
EZZ-PACK
 50 pcs. - Zinc Zap-In
 50 pcs. - #8 x 1" Combo Screws
 1 pc. - #2 X 2" Phillips Bit
List \$25.46



ZAP-IN Anchors - Nylon

Part #	OAL	Description	Box Qty.	Packaged	List / C
EZN1212	1-3/4"	ZAP-IN Nylon Anchor	100	BOX	call
EZN1212B	1-3/4"	ZAP-IN Nylon Anchor	5,000	BULK	call
EZN1012	1-5/16"	ZAP-IN JR. Nylon Anchor	100	BOX	call
EZN1012B	1-5/16"	ZAP-IN JR. Nylon Anchor	5,000	BULK	call



ZAP-IN Anchors - Zamac

Part #	OAL	Description	Box Qty.	Packaged	List / C
EZZ1212	1-3/4"	ZAP IN ZINC ANCHOR	100	BOX	call
EZZ1212B	1-3/4"	ZAP IN ZINC ANCHOR	5,000	BULK	call
EZZ1012	1-5/16"	ZAP IN JR. ZINC ANCHOR	100	BOX	call
EZZ1012B	1-5/16"	ZAP IN JR. ZINC ANCHOR	5,000	BULK	call



Hammer Drive Nail-In Anchors - Zamac

Part #	Size	Description	Drill	Box Qty.	List / C
HD14340	1/4" X 3/4"	MUSHROOM	1/4"	100	call
HD14010	1/4" X 1"	MUSHROOM	1/4"	100	call
HD14114	1/4" X 1-1/4"	MUSHROOM	1/4"	50	call
HD14112	1/4" X 1-1/2"	MUSHROOM	1/4"	50	call
HD14200	1/4" X 2"	MUSHROOM	1/4"	50	call

Meets or exceeds GSA Specification FF-S-325, Group V, Type 2, Class 3.



Split Drive Anchors - Zinc Plated

Part #	Size	Minimum Embedment	Drill	Box Qty.	List / C
FDA14150	1/4" X 1-1/2"	1-1/8"	1/4"	100	call
FDA14200	1/4" X 2"	1-1/8"	1/4"	100	call
FDA14250	1/4" X 2-1/2"	1-1/8"	1/4"	100	call
FDA14300	1/4" X 3"	1-1/8"	1/4"	100	call
FDA14350	1/4" X 3-1/2"	1-1/8"	1/4"	100	call
FDA14400	1/4" X 4"	1-1/8"	1/4"	100	call

Meets or exceeds GSA Specification FF-S-325, Group IV.



All specs available upon request.



1 Insert either #2 or #3 Phillips Driver bit into the recess of Zap-In anchor head. Use screw driver or screw gun.



2 Push Zap-In anchor into surface of wallboard until the two cutting blades penetrate the surface. Using gentle forward pressure, rotate anchor until collar sets flush to surface of wall.

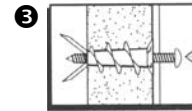

3 Use #8 Screws, minimum 3/4" long.
Wall board should be 3/8" - 1" thick.

Put fixture in place, insert screw & tighten until secure.

EASY TO INSTALL

No screws necessary. Just drill 1/4" hole and hammer in the anchor.

- Hollow Wall
- Solid Wall
- Concrete
- Stone
- Brick
- Plaster
- Sheet Metal

EASY TO INSTALL

No screws necessary. Just drill 1/4" hole and hammer in the anchor.

- ◆ Carbon Steel Construction
- ◆ Flat Head
- Concrete
- Stone
- Solid Brick

MAIN OFFICE
 INTERNATIONAL TOOL MANUFACTURING
 71-08 51ST. AVENUE, WOODSIDE, NY 11377
 (718) 446-0711 - (800) 247-5696 - FAX (718) 899-6553



INTERNATIONAL TOOL MANUFACTURING
 675-E-PROGRESS CENTER AVE., LAWRENCEVILLE, GA 30043
 (770) 962-5454 - (800) 229-1776 - FAX (770) 962-5869



STEP BY STEP
 INSTALLATION INSTRUCTIONS

- Drill hole to indicated drill size & bolt length.
- Insert expansion anchor with threaded end bottom first. Anchor should be flush with surface, or slightly above surface plane.
- Insert screw or bolt and tighten.
- Length of screw should equal bolt length plus thickness of fixture used.

Double Expansion Anchor - Zamac

Part #	Size	OAL	Drill	Box Qty.	List / C
DES1664	1/4" - 20	1"	1/2"	50	call
DES2064	5/16" - 18	1-1/4"	5/8"	50	call
DES2464	3/8" - 16	1-1/2"	3/4"	50	call
DES3264	1/2" - 13	2"	7/8"	25	call
DES4064	5/8" - 11	2-1/4"	1"	20	call
DES4864	3/4" - 10	2-7/8"	1-1/4"	10	call

Meets or exceeds GSA Specification FF-S-325, Group II, Type 2, Class 2, Style 2.



ITM manufactures any of the following anchors upon demand:

- Round Head Split Shank
- Lag Shield - Short/Long
- Single Expansion
- Machine Screw
- Drop-in
- Nylon Nail-in
- Plastic - All Colors

Accessories



5 Pack
 Non-Toxic Dust
 Masks
SINGLE STRAP
 Part # MSK55
 List \$1.75



50 Pack
 Non-Toxic Dust
 Masks
SINGLE STRAP
 Part # MAS0001
 List \$13.25



50 Pack
 Non-Toxic Dust
 Masks
DOUBLE STRAP
 Part # MAS0002
 List \$14.99



1 Pack
 Safety Goggles
 Part # GOG0001
 List \$4.15



5 Pack
 Replacement Blades
 Heavy Duty
 Part # HDB9005
 List \$1.95



100 Pack
 Replacement Blades
 Heavy Duty
 Part # HDB9100
 List \$21.95



1 Pack
 Carded Utility Knife
 Retractable Blade
 Part # UTK0001
 List \$5.99



1 Card
 Wallboard Saw
 12 / Pack
 Part # WS-6
 List \$5.55

Retractable 3 Blade Positions.

Smooth Ergonomic Design.

Extra Blade Inside Compartment.



Retractable 3 Blade Positions.



Extra Blade Inside Compartment.

Pull Out Mechanism For Quick
 Blade Change.



12 Pack
 Quick Release Knife
 Part # UTK0002
 List \$11.99 / Knife

- RED
- YELLOW
- GREEN

**Free Counter
 Display With
 Every Order!**



24 Pack
 Utility Knife
 Part # UTK0001-B
 List \$5.92 / Knife



EPS

Engineered Products & Services

Call 800-247-5696



From Concept ①

... to Production ②

... to Delivered Product ③

... in 90 Days.

①

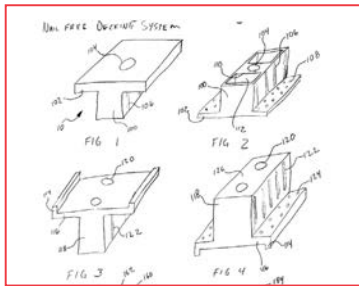

②

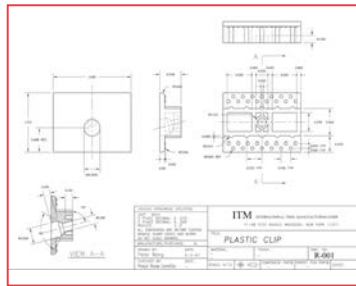

③



- Nearly 30 years of manufacturing experience.
- State-of-the-art ISO 9000 certified factories in Asia, Europe, and USA.
- Two USA distribution points.

Possibilities.

Expertise.



International Tool Manufacturing

71-08 51st Avenue
Woodside, NY 11377
Tel: 800-247-5696
Fax: 718-899-6553



675-E-Progress Ctr. Avenue
Lawrenceville, GA 30043
Tel: 800-229-1776
Fax: 770-962-5869



Engineered Products & Services

Call 800-247-5696

Need a special tool or part?

We can make it.

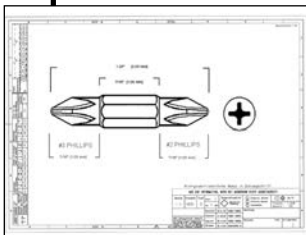
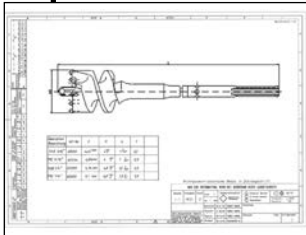
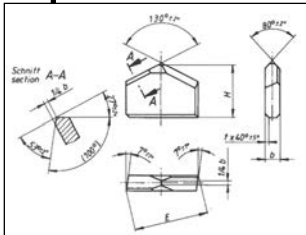
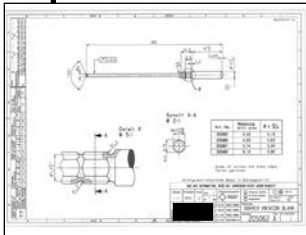
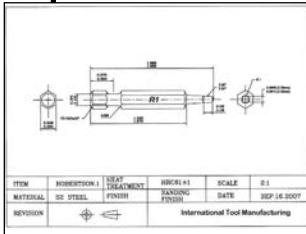
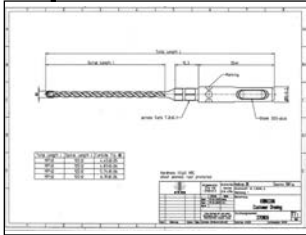

SPECIALIZATION

- Drilling Tools
- Hand Tools
- Drivers
- Fasteners
- Cutting Tools
- Components

CAPABILITIES

- Plating / Coatings
- Packaging Design & Production
- Kits / Merchandising
- Private Branding
- Barcoding
- Print Ready Digital Photo

MATERIALS

- HSS
- S2 Modified Steel
- Stainless & PH Steel
- Chrome Vanadium
- Carbon & Alloy Steel
- Carbides
- Nylons
- PP / PVC

VALUE ADDED SERVICES

- Inventory Management
- Auto-Stock Replenishment
- Reduced Procurement Costs
- Design / R&D
- Quality Control
- Educational / Training
- Compliance & Material Cert.
- Warehousing
- Drop Ship Programs

... new possibilities brought to you by



BI-METAL HOLE SAW CROSS REFERENCE

Size	ITM #	American Saw (Lenox)	Black & Decker	Dewalt	MagSaw	Makita	Milford Sandvik	Morse	Starrett
9/16"	275HW0011	30009-9L	21820	DW1820	624.0916	7140 01-A	44774	AV09	H0096
5/8"	275HW0012	30010-10L	21821	DW1821	624.1016	7140 02-A	44776	AV10	H0058
11/16"	275HW0013	30011-11L	21822	DW1822	624.1116	7140 03-A	44778	AV11	H1016
3/4"	275HW0014	30012-12L	21823	DW1823	624.1216	7140 04-A	44780	AV12	H0034
13/16"	275HW0015	30013-13L	21824	DW1824	624.1316	7140 05-A	44782	AV13	H1036
7/8"	275HW0016	30014-14L	21825	DW1825	624.1416	7140 06-A	44784	AV14	H0078
15/16"	275HW0017	30015-15L	21826	DW1826	624.1516	7140 07-A	44786	AV15	H1056
1"	275HW0018	30016-16L	21827	DW1827	624.1616	7140 08-A	44788	AV16	H0100
1-1/16"	275HW0185	30017-17L	21828	DW1828	624.1716	7140 09-A	44790	AV17	H0116
1-1/8"	275HW0019	30018-18L	21829	DW1829	624.1816	7140 10-A	44792	AV18	H0118
1-13/16"	275HW0020	30019-19L	21830	DW1830	624.1916	7140 11-A	44794	AV19	H0136
1-1/4"	275HW0021	30020-20L	21831	DW1831	624.2016	7140 12-A	44796	AV20	H0114
1-5/16"	275HW0022	30021-21L	21832	DW1832	624.2116	7140 13-A	44798	AV21	H0152
1-3/8"	275HW0023	30022-22L	21833	DW1833	624.2216	7140 14-A	44800	AV22	H0138
1-7/16"	275HW0123	30023-23L	21834	DW1834	624.2316	7140 15-A	44802	AV23	H0176
1-1/2"	275HW0024	30024-24L	21835	DW1835	624.2416	7140 16-A	44804	AV24	H0112
1-9/16"	275HW0124	30025-25L	21836	DW1836	624.2516	7140 17-A	44806	AV25	H0196
1-5/8"	275HW0025	30026-26L	21837	DW1837	624.2616	7140 18-A	44808	AV26	H0158
1-11/16"	275HW0125	30027-27L	21838	DW1838	624.2716	7140 19-A	44810	AV27	H1116
1-3/4"	275HW0026	30028-28L	21839	DW1839	624.2816	7140 20-A	44812	AV28	H0134
1-13/16"	275HW0126	30029-29L	21840	DW1840	624.2916	7140 21-A	44814	AV29	H1136
1-7/8"	275HW0027	30030-30L	21841	DW1841	624.3016	7140 22-A	44816	AV30	H0178
2"	275HW0028	30032-32L	21842	DW1842	624.3216	7140 23-A	44818	AV32	H0200
2-1/16"	275HW0128	30033-33L	21843	DW1843	624.3316	7140 24-A	44820	AV33	H0216
2-1/8"	275HW0029	30034-34L	21844	DW1844	624.3416	7140 25-A	44822	AV34	H0218
2-1/4"	275HW0030	30036-36L	21845	DW1845	624.3616	7140 26-A	44824	AV36	H0214
2-5/16"	275HW0031	30037-37L	21846	DW1846	624.3716	7140 27-A	44826	AV37	H0256
2-3/8"	275HW0032	30038-38L	21847	DW1847	624.3816	7140 28-A	44828	AV38	H0238
2-1/2"	275HW0033	30040-40L	21848	DW1848	624.4016	7140 29-A	44830	AV40	H0212
2-9/16"	275HW0034	30041-41L	21849	DW1849	624.4116	7140 30-A	44832	AV41	H0296
2-5/8"	275HW0134	30042-42L	21850	DW1850	624.4216	7140 31-A	44834	AV42	H0258
2-3/4"	275HW0135	30044-44L	21851	DW1851	624.4416	7140 32-A	44836	AV44	H0234
2-7/8"	275HW0136	30046-46L	21852	DW1852	624.4616	7140 33-A	44838	AV46	H0278
3"	275HW0035	30048-48L	21853	DW1853	624.4816	7140 34-A	44840	AV48	H0300
3-1/8"	275HW0137	30050-50L	21854	DW1854	624.5016	7140 35-A	44842	AV50	H0318
3-1/4"	275HW0138	30052-52L	21855	DW1855	624.5216	7140 36-A	44844	AV52	H0314
3-3/8"	275HW0139	30054-54L	21856	DW1856	624.5416	7140 37-A	44846	AV54	H0338
3-1/2"	275HW0036	30056-56L	21857	DW1857	624.5616	7140 38-A	44848	AV56	H0312
3-5/8"	275HW0140	30058-58L	21858	DW1858	624.5816	7140 39-A	44850	AV58	H0358
3-3/4"	275HW0141	30060-60L	21859	DW1859	624.6016	7140 40-A	44852	AV60	H0334
3-7/8"	275HW0142	30062-62L	21860	DW1860	624.6216	7140 41-A	44854	AV62	H0378
4"	275HW0037	30064-64L	21861	DW1861	624.6416	7140 42-A	44856	AV64	H0400
4-1/8"	275HW0143	30066-66L	21862	DW1862	624.6616	7140 43-A	44858	AV66	H0418-
1/4"	275HW0144	30068-68L	21863	DW1863	624.6816	7140 44-A	44860	AV68	H0414
4-3/8"	N/A	30070-70L	21864	DW1864	624.7016	7140 45-A	44861	AV70	H0138
4-1/2"	275HW0038	30070-72L	21865	DW1865	624.7216	7140 46-A	44862	AV72	H0412
4-3/4"	275HW0145	30078-78L	21866	DW1866	624.7616	7140 47-A	44864	AV76	H0434
5"	275HW0039	30080-80L	21867	DW1867	624.8016	7140 48-A	44866	AV80	H0500
5-1/2"	275HW0040	30088-88L	21869	DW1868	624.8816	7140 49-A	44868	AV88	H0512
5-3/4"	275HW0146	N/A	N/A	N/A	624.9216	N/A	N/A	AV92	N/A
6"	275HW0041	30096-96L	21871	DW1871	624.9616	7140 50-A	44470	AV96	H0600

ARBOR CROSS REFERENCE (LENOX)

ITM #	American Saw (Lenox)	Description
276AR0002	30001-1L	9/16" TO 1-3/16" ARBOR 7/16
276AR0003	30002-2L	1-1/4" TO 6" ARBOR 7/16" HEX
N/A	30003-3L	
276AR0001	30004-4L	9/16" TO 1-3/16" ARBOR 1/4"
N/A	30005-5L	
276AR0035	30006-6L	1-1/4" TO 6" ARBOR 3/8" HEX

HSS STEP-DRILL CROSS REFERENCE

ITM #	Greenlee	Klein	Lenox	Mag Bit	Magna	Milwaukee	M.K. Morse	Uni-Bit	VA
274MC0001	34401	59001	VB1	851.0500A-01	44685	48-78-9100	ESD01	1	13370
274MC0002	36402	59005	VB4	851.0500B-02	44694	N/A	ESD02	2	N/A
274MC0003	N/A	59003	VB3	851.0750-03	44687	48-89-9105	ESD04	3	13372
274MC0004	34403	59014	N/A	851.0875-04	44692	48-89-9130	ESD03	4	N/A
274MC0005	N/A	N/A	N/A	851.1125-05	N/A	N/A	N/A	N/A	N/A
274MC0006	N/A	59004	N/A	851.1375-06	N/A	N/A	N/A	N/A	N/A
274MC0007	N/A	N/A	N/A	851.0750B-09	N/A	N/A	N/A	N/A	N/A
274MC0008	36413	59011	VB11	851.1125B-11	44691	48-89-9135	ESD05	N/A	N/A
274MC0009	46414	N/A	VB12	851.1375B-12	N/A	N/A	N/A	N/A	N/A
274MC0010	34411	59008	VB7	850.0875-07	44688	48-89-9115	ESD10	11	13373