



In this catalogue...

Power and High Voltage

Elastimold® / Fisher Pierce® Cable AccessoriesSection A

Homac® / Blackburn® Overhead ConnectorsSection B

Homac® Underground DistributionSection C

Boreal® Flexible Braids.....Section D

Russellstoll® Electrical Interconnection SystemsSection E

Alphanumerical IndexSection F



Table of Contents

Introduction	A2
Ratings	A3–A4
Standard Interfaces	A5
200 A Loadbreak	A6–A9
200 A Deadbreak	A10–A11
600 Series Deadbreak	A12–A15
600 Series Deadbreak – Cam-Op™, Link-Op™	A16–A17
600 Series Deadbreak – Stick-Op™, Window-Op™	A18–A19
600 Series Deadbreak – Cable Joints	A20–A21
Molded Multi-Point Junctions	A22–A23
PCJ™ Power Cable Joints	A24–A25
Cable Terminations	A26–A29
Shield Adapters, Sealing and Grounding	A30–A31
Equipment Bushings	A32
How to Specify Size-Sensitive Products	A33–A34
AEIC and ICEA Cable Insulation Diameter	A35–A38
WX Size Tables	A39–A41
Shrink-Fit Cable Joints	A42–A43
Ranger2™ Terminations	A44–A49
Faulted Circuit Indicators	A50–A57
Underground Distribution Switchgear	A58–A69
Molded Fuse Products	A70–A79
Surge Arresters	A80–A85
Molded Vacuum Recloser	A86–A87



Introduction

This section provides an easy-to-use, comprehensive listing of Elastimold® products for 5 kV thru 35 kV underground power distribution systems. Included are separable elbow connectors, cable joints, terminations and other cable accessory components. This catalogue incorporates information relative to product application, ratings and selection.

The Thomas & Betts Elastimold® brand is recognized as the leading producer of premolded cable accessory components worldwide. Utilizing specially formulated materials with 100% peroxide-cured insulation and shielding, Elastimold products represent the state-of-the-art in premolded process technology. Durable, quality construction and non-degrading, high-reliability, maintenance-free performance is assured when specifying Elastimold products.

Elastimold's broad line of premolded products offers significant advantages over field-fabricated and other alternatives, including: 100% factory assurance testing prior to delivery and installation; simplified, single-piece construction with built-in insulating, shielding and sealing surfaces; ease of installation with no special skills or tools required; and compact, lightweight, durable designs for easy handling and application.

Separable Elbow Connectors and their related accessories are available in 200 A loadbreak, 200 A deadbreak and 600 A deadbreak styles. Rated for padmount, subsurface, vault, indoor, outdoor and other applications, units feature interchangeable interfaces which can be easily engaged or separated to provide a convenient method to connect or disconnect cable and equipment in a distribution system.

Cable Joints are available in permanently crimped or bolted (separable) connector styles. Permanently crimped units are rated the same as the cable they are connecting and are available for all applications including direct buried.

Cable Terminations are available in single-piece or modular designs. Rated for indoor, outdoor or padmount applications, units allow connection and transition from shielded underground cables to bare overhead conductors and live-front equipment.

Elastimold Special Component Services Group provides custom products tailored to specific application requirements. Please contact the factory for further information regarding this service. For Surge Arresters see pages A80 to A85 and Fused Elbows, see pages A70 to A79.



Ratings

.....

Certified Tests and Performance

Elastimold® Separable Connectors, Cable Joints, Cable Terminators and other cable accessory products have been designed and tested per applicable portions of IEEE, ANSI and other industry standards including:

- IEEE 386™ Standard For Separable Connectors
- IEEE 404™ Standard For Cable Joints and Splices
- IEEE 48™ Standard For Cable Terminations
- IEEE 592™ Standard For Exposed Semiconducting Shields
- ANSI C119.4 Standard For Copper and Aluminum Conductor Connectors
- AEIC CS8 Standards For XLP and EPR Insulated Cables
- ICEA S-94-649-2004 and S-97-682-2000 Standard for Cables Rated 5,000 – 46,000 V

Cable Joints and Terminations Ratings

Refer to the pages listed below for rating information:

- PCJ Cable Joints, page A24
- Cable Terminations, page A26 to A29

Separable Connector Ratings

Table 1 shows voltage and current ratings which apply to all Separable Connectors including 200 A Loadbreak, 200 A Deadbreak and 600 Series Deadbreak products. Table 2 shows switching and fault close ratings which only apply to 200 A Loadbreak Connectors.



Ratings

Certified Tests and Performance (cont'd)

Table 1	15 kV Class Ratings	25 kV Class Ratings	35 kV Class Ratings
<ul style="list-style-type: none"> OPERATING VOLTAGE Maximum line-to-ground (See Application Info Note 1) 	8.3 kV	15.2 kV	21.1 kV
<ul style="list-style-type: none"> BIL Impulse withstand 1.2 x 50 microsecond wave 	95 kV	125 kV	150 kV
<ul style="list-style-type: none"> WITHSTAND VOLTAGE AC One Minute DC Fifteen Minute 	34 kV 53 kV	40 kV 78 kV	50 kV 103 kV
<ul style="list-style-type: none"> CORONA EXTINCTION LEVEL @ 3pC Sensitivity 	11 kV	19 kV	26 kV
200 A Products Continuous Current: Symmetrical Momentary Current: 600 Series Products Continuous Current: Symmetrical Momentary Current:	200 A* 10 kA sym, 10 cycle duration 600 and 900 A* 25 kA sym, 10 cycle duration * Designed for 90°C maximum continuous operating temperature		

Table 2	Loadmake/Loadbreak Switching	Fault Close
15 kV Class Ratings	<ul style="list-style-type: none"> 1Ø and 3Ø circuits 8.3 kV line to ground, 14.4 kV max. across open contacts. 10 loadmake/break operations at 200 A max. with 70 to 80% lagging power factor. 	1 fault close operation at 8.3 kV or 14.4 kV; 10,000 A, rms, sym. 10 cycles (0.17 sec.) 1.3 max. asym factor applies to new or used mating parts (up to maximum designated switching operations.)
25 kV Class Ratings	<ul style="list-style-type: none"> 1Ø and 3Ø circuits 15.2 kV line to ground, 26.3 kV max. across open contacts. 10 loadmake/break operations at 200 A max. with 70 to 80% lagging power factor. 	1 fault close operation at 15.2 kV or 26.3 kV; 10,000 A, rms, sym. 10 cycles (0.17 sec.) 1.3 max. asym factor applies to new or used mating parts (up to maximum designated switching operations.)
35 kV Class Ratings	<ul style="list-style-type: none"> 1Ø and 3Ø circuits 21.1 kV line to ground, 36.6 kV max. across open contacts. 10 loadmake/break operations at 200 A max. with 70 to 80% lagging power factor. 	1 fault close operation at 21.1 kV or 36.6 kV; 10,000 A, rms, sym. 10 cycles (0.17 sec.) 1.3 max. asym factor applies to new or used mating parts (up to maximum designated switching operations.)

Application Information:

1. Loadbreak connectors are designed and rated for use on grounded WYE systems. For application on ungrounded WYE or delta systems, the next higher voltage class product is recommended. Examples: 5 kV ungrounded: use 15 kV class products; 15 kV ungrounded: use 25 kV class products; 25 kV ungrounded: use 35 kV class products.
2. Products are designed and constructed for all applications including padmount, subsurface, vault, indoor, outdoor, direct sunlight, direct buried and continuously submerged in water.
3. Products are designed and rated for ambient temperatures of -40°C to +65°C. It is recommended that loadbreak connectors be hotstick operated at -20°C to +65°C ambient temperature range and at altitudes not exceeding 6000 ft.

Standard Interfaces

Standard Interfaces for Separable Connectors, Components and Equipment Bushings

ANSI/IEEE Standard 386 defines the specific interface dimensions that 200 A and 600 Series elbows, inserts, junctions, equipment bushings and any mating components must conform to insure interchangeability. The table below provides information concerning the types of interfaces supplied by Elastimold for various applications and is useful to assure proper matching of components.

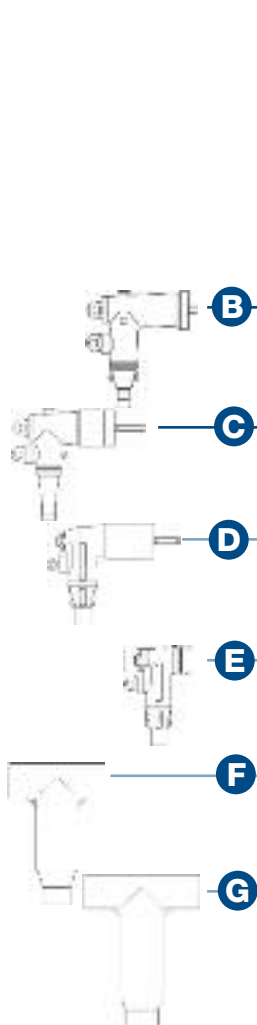

Bushing Interface	Voltage Class	Interface Description	Standard No. Figure No
A 200 A DEEPWELL EQUIPMENT BUSHING	15 kV, 25 kV and 35 kV	200 A Bushing Well Interface 8.3 kV, 15.2 kV, 21.1 kV	A IEEE 386-2001 Fig. 3
B 200 A LOADBREAK INSERT	15 kV	200 A Loadbreak 8.3 kV and 8.3 kV/14.4 kV	B IEEE 386-2001 Fig. 5
C 200 A LOADBREAK INSERT	25 kV	200 A Loadbreak 15.2 kV and 15.2 kV/26.3 kV	C IEEE 386-2001 Fig. 7, Note 1
D 200 A LOADBREAK INSERT	35 kV	200 A Loadbreak Interface No. 2 21.1 kV and 21.1 kV/36.6 kV	D IEEE 386-2001 Fig. 7, Note 1
E 200 A DEADBREAK INSERT	15 kV and 25 kV	200 A Deadbreak 8.3 kV and 15.2 kV	E IEEE 386-2001 Fig. 4
F 600 SERIES EQUIPMENT BUSHING	15 kV and 25 kV	600 A Deadbreak Interface No.1 8.3 kV and 15.2 kV	F IEEE 386-2001 Fig. 11
G 600 SERIES EQUIPMENT BUSHING	35 kV	600 A Deadbreak Interface No.1 21.1 kV	G IEEE 386-2001 Fig. 13

1. Elastimold uses Fig. 7 interface for both 25 and 35 kV applications.

200 A Loadbreak

200 A loadbreak connectors and accessories provide a convenient method to connect/disconnect cable and equipment on power distribution systems. Loadbreak elbows include provisions for energized operation using standard hotstick tools, allowing loadmake/break operation and a visible disconnect. Components can be isolated with insulated caps, plugs and parking bushings.

Optional accessories allow system grounding, testing, bypass, lightning surge protection and current limiting fusing. Additional connecting points and taps can be provided by use of junctions or feed-thrus.



Ratings Overview

See page A3–A4 for complete information including switching and fault close ratings.

Current Ratings

200 A Continuous
10 kA sym., 10 Cycles

Voltage Ratings

15 kV Class

8.3 kV Phase-to-Ground
14.4 kV Phase-to-Phase
95 kV BIL

34 kV AC Withstand
53 kV DC Withstand

11 kV Corona Extinction

25 kV Class

15.2 kV Phase-to-Ground
26.3 kV Phase-to-Phase
125 kV BIL

40 kV AC Withstand
78 kV DC Withstand

19 kV Corona Extinction

35 kV Class

21.1 kV Phase-to-Ground
36.6 kV Phase-to-Phase
150 kV BIL

50 kV AC Withstand
103 kV DC Withstand

26 kV Corona Extinction

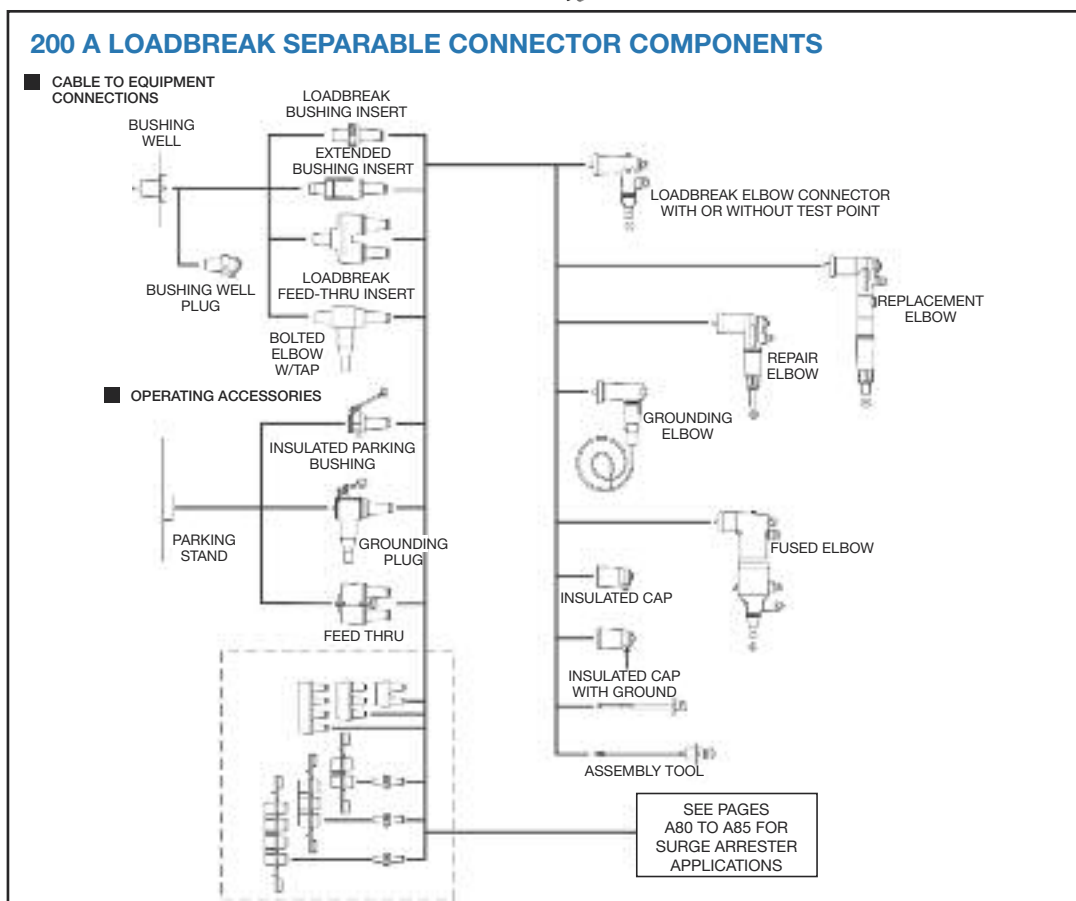

200 A Loadbreak

Illustration (not to scale)	Description	Voltage Class	ELASTIMOLD Cat. No.	Notes
	Elbow Connector	15 kV	165LR-W5X Use Tables W1 and X1	N2, 3, 4, 5
		25 kV	275LR-W5X Use Tables W16 and X1	N2, 3, 4, 5
		35 kV	375LR-W5X Use Tables W3 and X2	N2, 3, 5
	Elbow Connector w/ Test Point	15 kV	166LR-W5X Use Tables W1 and X1	N2, 3, 4, 5, 24
		25 kV	276LR-W5X Use Tables W16 and X1	N2, 3, 4, 5, 24
		35 kV	376LR-W5X Use Tables W3 and X2	N2, 3, 5, 24
	Jacket Seal Elbow Connector	15 kV	165LRJS-W5X Use Tables W1 and X1	N2, 19
		25 kV	275LRJS-W5X Use Tables W16 and X1	N2, 19
	Jacket Seal Elbow Connector w/ Test Point	15 kV	166LRJS-W5X Use Tables W1 and X1	N2, 19, 24
		25 kV	276LRJS-W5X Use Tables W16 and X1	N2, 19, 24
	Repair Elbow Connector	15 kV	167ELR-W5X Use Tables W5 and X1	N5, 10, 18
		25 kV	273ELR-W5X Use Tables W5 and X1	N5, 10, 18
	Repair Elbow Connector w/ Test Point	15 kV	168ELR-W5X Use Tables W5 and X1	N5, 10, 18, 24
		25 kV	274ELR-W5X Use Tables W5 and X1	N5, 10, 18, 24
	Replacement Elbow	15 kV	167RLR-W5X Use Tables W4 and X1	N5, 11, 13
		25 kV	273RLR-W5X Use Tables W2 and X1	N5, 11, 13
	Replacement Elbow w/ Test Point	15 kV	168RLR-W5X Use Tables W4 and X1	N5, 11, 13, 24
		25 kV	274RLR-W5X Use Tables W2 and X1	N5, 11, 13, 24
	Direct Test Elbow Connector	15 kV	167DLR-W5X Use Tables W4 and X1	N2, 5, 22
		25 kV	273DLR-W5X Use Tables W2 and X1	N2, 5, 22
	Direct Test Repair Elbow Connector	15 kV	167DELR-W5X Use Tables W5 and X1	N5, 10, 18, 22
		25 kV	273DELR-W5X Use Tables W5 and X1	N5, 10, 18, 22
	Direct Test Repair Elbow Connector w/ Test Point	15 kV	168DELR-W5X Use Tables W5 and X1	N5, 10, 18, 22, 24
		25 kV	274DELR-W5X Use Tables W5 and X1	N5, 10, 18, 22, 24
	Fused Elbow (Full Range Current Limiting)	15 kV	168FLR H-WOX 274FLR H-WOX See Product Guide PG-PC-H	
		25 kV		
	Bolted Elbow w/ Tap	15 kV	167LRT-W5X Use Tables W4 and X1	N17
	Bushing Insert	15 kV	1601A4	N4, 8, 20
		25 kV	2701A4	N4, 8, 20
		35 kV	3701A4	N6, 21
		35 kV	3701A3	N8, 21
	Extended Bushing Insert	15 kV	1601EA4	N8, 20
		25 kV	2701EA4	N8, 20
	Feed-Thru Insert	15 kV	1602A3R	N16
		25 kV	2702A1	N16
		35 kV	3702A1	N6, 16
	Insulated Cap	15 kV	160DR	N9
	Insulated Cap w/ Ground	15 kV	160DRG	N9
		15 kV	167DRG	N7, 9
		25 kV	273DRG	N7, 9
		35 kV	375DRG	N7, 9

Illustration (not to scale)	Description	Voltage Class	ELASTIMOLD Cat. No.	Notes
	Insulated Cap w/ Ground and Test Point	15 kV	168DRG	N7
		25 kV	274DRG	N7
		35 kV	376DRG	N7
	Grounding Plug (1/0 AWG x 6' Ground Lead)	15 kV	161GP	
		25 kV	272GP	
		15 kV	160GLR	
	Grounding Elbow (1/0 AWG x 6' Ground Lead)	25/35 kV	370GLR	N12
	Feed-Thru	15 kV	164FT	
		25 kV	274FT	
		35 kV	371FT	N16
	Feed-Thru Vertical	15 kV	164FTV	
		25 kV	274FTV	
		35 kV	373FTV	
	Adjustable Bracket 2-point Feed-Thru	15 kV	164FT2-AB	N23
		25 kV	274FT2-AB	N23
		35 kV	373FT2-AB	N23
	Adjustable Bracket 3-point Feed-Thru	15 kV	164FT3-AB	N23
		25 kV	274FT3-AB	N23
		35 kV	373FT3-AB	N23
	Adjustable Bracket 4-point Feed-Thru	15 kV	164FT4-AB	N23
		25 kV	274FT4-AB	N23
		35 kV	373FT4-AB	N23
	Feed-Thru Well	15/25 kV	K1601WFT	
	Feed-Thru Well Vertical	15/25 kV	K1601WFTV	
	Insulated Parking Bushing	15 kV	161SOP	N20
		25 kV	272SOP	N20
		35 kV	372SOP	N21
		15 kV	164SOP	N20, 23
	Test Rod	ALL	370TR	
	Bushing Well Plug	15/25 kV	276BWP	
		35 kV	M276BWP	
	Assembly Tool	ALL	200AT	N8

- N1. Copper lug for use on COPPER CONDUCTOR ONLY.
 N2. W5X indicates that the Cat. No. includes 02500X long bi-metal compression lug as standard. For an all-copper lug, replace W5X with W2X in Table X1 to specify the all-copper 02702X lug.
 N3. Also available as housing only. Specify: 165BLR-W; 275BLR-W; 375BLR-W; 166BLR-W; 276BLR-W; 376BLR-W.
 N4. Also available as elbow/insert combination. Specify: 165A4-WX; 275A4-WX; 166A4-WX; 276A4-WX.
 N5. Also available with 200ECS jacket seal included. Add - "S" suffix to Cat. No.
 N6. Rated for single-phase applications only.
 N7. Equipped with insulated cuff.
 N8. Includes internal torquing feature using 200AT Assembly Tool.
 N9. Also available without probe. Specify "A" suffix - Example: 273DRGA.
 N10. Repair elbow has extended length contact and elbow housing resulting in a net gain of 3-1/4 in. length.
 N11. Replacement elbow has extended length contact and elbow housing resulting in a net gain of 8-7/8 in. length.
 N12. Rated for 25 kV thru 35 kV applications.
 N13. Includes long bi-metal contact 00400X.
 N14. 160CA Cable Size Adapter can only be used with elbow Cat. No. 165LR/166LR C size only.
 N16. Fully rotatable for 360° positioning. Includes bail assembly to secure feed-thru insert to bushing well.
 N17. Includes 02800X bi-metal contact.
 N18. Includes 02509X long bi-metal contact.
 N19. Includes built-in jacket seal. Also available as housing only — specify: 165BLRJS-W, 166BLRJS-W, 275BLRJS-W or 276LRJS-W. Also available as elbow/insert combination — specify: 165JSA4-W5X, 166JSA4-W5X, 275JSA4-W5X or 276JSA4-W5X.
 N20. Includes a yellow seating indicator and vent ring.
 N21. Includes a black vent ring.
 N22. Direct Test Connectors, along with a 200TC-X series meter adapter, a properly rated voltage meter and Hot-line Stick provides a means for direct conductor voltage testing.
 N23. With stainless steel bracket.
 N24. Test Point Cap Cat# 156-7



Refer to the W and X tables on pages A39 to A41 for sizing to cable insulation diameter and conductor size. For cable shield adapters and jacket seals, see page A30.

200 A Loadbreak

Ratings Overview

See page A3–A4 for complete information including switching and fault close ratings.

Current Ratings

200 A Continuous
10 kA sym., 10 Cycles

Voltage Ratings

15 kV Class

8.3 kV Phase-to-Ground
14.4 kV Phase-to-Phase
95 kV BIL
34 kV AC Withstand
53 kV DC Withstand
11 kV Corona Extinction

25 kV Class

15.2 kV Phase-to-Ground
26.3 kV Phase-to-Phase
125 kV BIL
40 kV AC Withstand
78 kV DC Withstand
19 kV Corona Extinction

35 kV Class

21.1 kV Phase-to-Ground
36.6 kV Phase-to-Phase
150 kV BIL
50 kV AC Withstand
103 kV DC Withstand
26 kV Corona Extinction

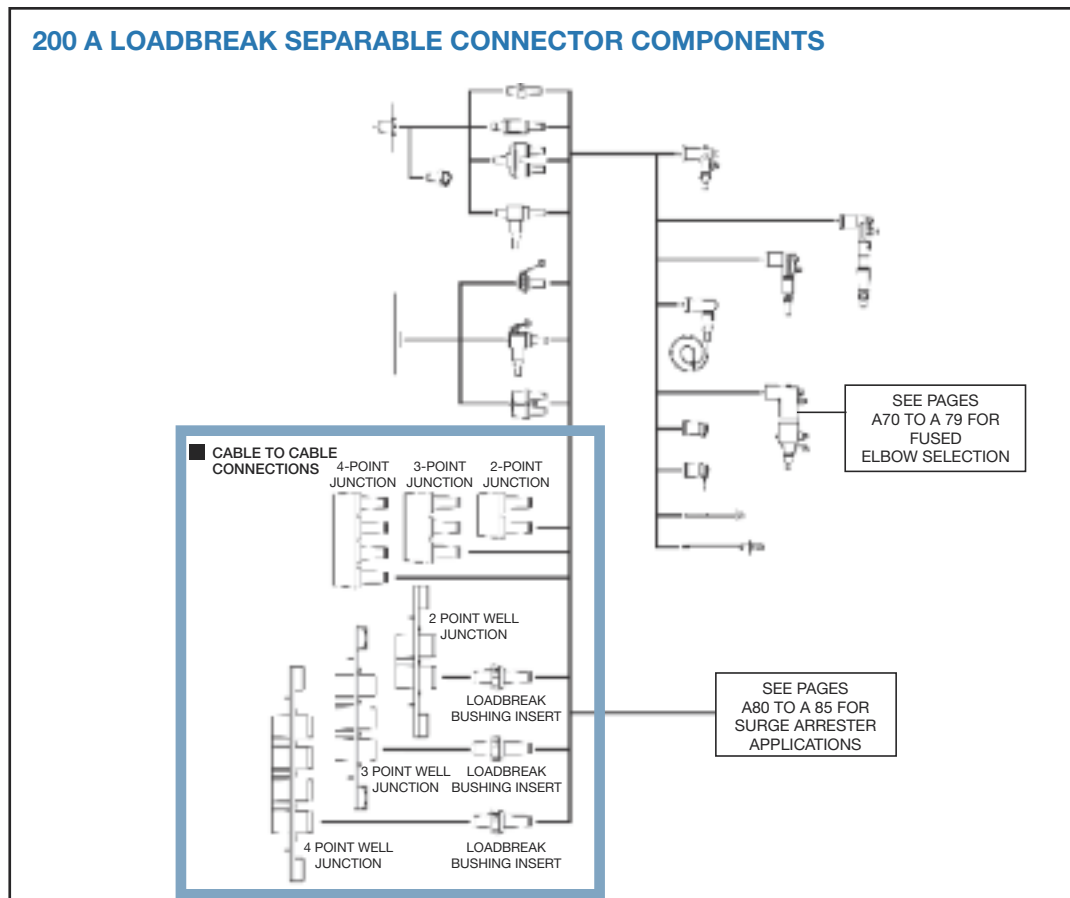

200 A Loadbreak

Illustration (not to scale)	Description	Voltage Class	ELASTIMOLD Cat. No.	Notes
	Contacts: Long Bi-Metal ELR Bi-Metal Copper LRT Contact RLR Contact	ALL 15/25 kV 02702X 02800X 15/25 kV	Use Table X1 02500X 02509X 02702X 02800X 00400X	N1 N2 N3
	Elbow Probe	15 kV 25 kV 35 kV	166LRF 274LRF 375LRF	
	Elbow Cable Entrance Insulating Plug	ALL	10EPW Use Table W6	
	Cable Size Adapter	15 kV	160CA-W Use Table W6 EB-FA Only	N4
	Direct Voltage Test Meter Adapter for: HD Electric Meters	ALL	200TC-1	N14
	Ross Meters		200TC-2	N14
	Chance Meters		200TC-4	N14
	2-Way Well Junction w/ s.s. Bracket	15/25 kV	K1601WJ2	N6
	2-Way Well Junction w/ "U" Straps	15/25 kV	K1601WJ2-5	N5, 6, 11
	3-Way Well Junction w/ s.s. Bracket	15/25 kV	K1601WJ3	N6
	3-Way Well Junction w/ "U" Straps	15/25 kV	K1601WJ3-5	N5, 6, 12
	4-Way Well Junction w/ s.s. Bracket	15/25 kV	K1601WJ4	N6
	4-Way Well Junction w/ "U" Straps	15/25 kV	K1601WJ4-5	N5, 6, 13

Illustration (not to scale)	Description	Voltage Class	ELASTIMOLD Cat. No.	Notes
	2-Point Junction with/Stainless Steel bracket	15 kV 25 kV 35 kV	164J2 274J2 373J2	N7 N7 N7
	2-Point Junction w/"U"-straps	15 kV 25 kV 35 kV	164J2-5 274J2-5 373J2-5	N5, 8 N5, 11 N5, 11
	3-Point Junction with/Stainless Steel bracket	15 kV 25 kV 35 kV	164J3 274J3 373J3	N7 N7 N7
	3-Point Junction w/"U"-straps	15 kV 25 kV 35 kV	164J3-5 274J3-5 373J3-5	N5, 9 N5, 12 N5, 12
	4-Point Junction with/Stainless Steel bracket	15 kV 25 kV 35 kV	164J4 274J4 373J4	N7 N7 N7
	4-Point Junction w/"U"-straps	15 kV 25 kV 35 kV	164J4-5 274J4-5 373J4-5	N5, 10 N5, 13 N5, 13

- N1. Repair elbow has extended length contact and elbow housing resulting in a net gain of 3-1/4 in. length.
 N2. Copper lug for use on COPPER CONDUCTOR ONLY.
 N3. Replacement elbow has extended length contact and elbow housing resulting in a net gain of 8-7/8 in. length.
 N4. 160CA Cable Size Adapter can only be used with elbow part numbers 165LR/166LR C size only.
 N5. Also available as rubber only, without straps. Specify suffix "-4" in place of "-5" in the Cat. No.
 N6. Supplied with replaceable stud. Replacement stud available separately. Specify 1000-150.
 N7. Hardware packages, consisting of brackets and straps only, may be ordered separately by specifying "-6" in the Cat. No. Example 164J4-6
 N8. Hardware package, consists of "U"-straps and back plate only, may be ordered separately by specifying 1601US-J2.
 N9. Hardware package, consists of "U"-straps and back plate only, may be ordered separately by specifying 1601US-J3.
 N10. Hardware package, consists of "U"-straps and back plate only, may be ordered separately by specifying 1601US-J4.
 N11. Hardware package, consists of "U"-straps and back plate only, may be ordered separately by specifying 271-68.
 N12. Hardware package, consists of "U"-straps and back plate only, may be ordered separately by specifying 271-61.
 N13. Hardware package, consists of "U"-straps and back plate only, may be ordered separately by specifying 271-70.
 N14. For use with Direct Test Connectors.

200 A Deadbreak

200 A deadbreak connectors and accessories provide a quick disconnect feature for cable and equipment connections on power distribution systems.

All deadbreak connectors must be DE-ENERGIZED before operating and must be mechanically secured with bails when connected. Components can be isolated with insulated caps, plugs and parking bushings.

All deadbreak elbows are equipped with test points as standard. Optional accessories allow system grounding, bypass and lightning surge protection. Additional connecting points and taps can be provided by use of junctions or feed-thrus.



Ratings Overview

See page A3–A4 for complete information including switching and fault close ratings.

Current Ratings

200 A Continuous
10 kA sym., 10 Cycles

Voltage Ratings

15 kV Class
8.3 kV Phase-to-Ground
14.4 kV Phase-to-Phase
95 kV BIL
34 kV AC Withstand
53 kV DC Withstand
11 kV Corona Extinction

25 kV Class
15.2 kV Phase-to-Ground
26.3 kV Phase-to-Phase
125 kV BIL
40 kV AC Withstand
78 kV DC Withstand
19 kV Corona Extinction

200 A DEADBREAK SEPARABLE CONNECTOR COMPONENTS

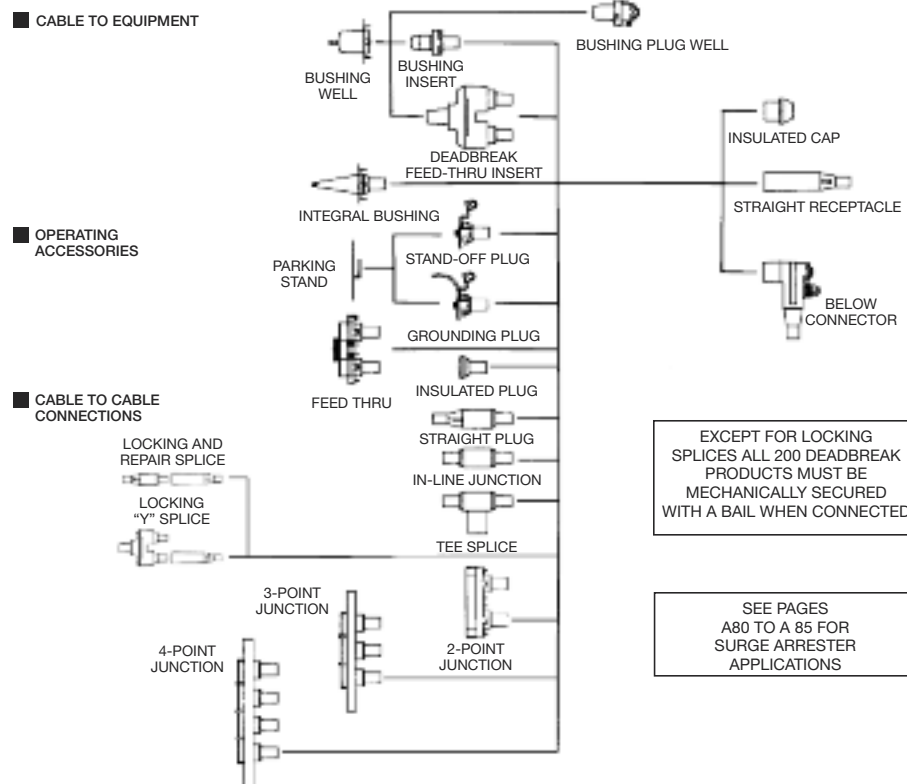

200 A Deadbreak

Illustration (not to scale)	Description	Voltage Class	ELASTIMOLD Cat. No.	Notes
	Elbow Connector w/ Test Point	15/25 kV	156LR-W5X Use Tables W4 and X1	N1, 2
	Direct Test Elbow Connector	15/25 kV	156DLR-W5X Use Tables W4 and X1	N1, 2, 22
	Bail Assembly for 156LR Elbow	15/25 kV	150BA	
	Bushing Insert	15/25 kV	BK1501A1	N3
	Feed-thru Insert	15/25 kV	K1502A1	N3, 4
	Insulated Plug	15/25 kV	K150DP	N3
	Insulated Cap	15/25 kV	K150DR	N3
	Insulated Parking Bushing	15/25 kV	K151SOP	N3
	Grounding Plug	15/25 kV	151GP	N3
	Feed-Thru	15/25 kV	K1501FT	N3, 6
	2-Point Junction	15/25 kV	K1501J2-U	N3, 6
	3-Point Junction	15/25 kV	K1501J3-U	N3, 6
	4-Point Junction	15/25 kV	K1501J4-U	N3, 6
	Elbow Probe	15/25 kV	156LRF	
	Straight Receptacle	15/25 kV	K151SR-WOX Use Tables W1 and X1	N3, 12, 13, 17, 18
	Straight Plug	15/25 kV	K151SP-WOX Use Tables W1 and X1	N3, 12, 13, 19
	Tee Splice	15/25 kV	K150T	N3
	In-Line Junction	15/25 kV	K150S	N3
	Locking Splice/Repair Splice	15/25 kV	K151LS-WOX Use Tables W1A and X1	N8, 9, 13, 15, 16, 17, 20, 23
	Locking "Y" Splice	15/25 kV	K151LY-WOX Use Tables W1A and X1	N8, 9, 13, 15, 17, 21
	BAIL	15/25 kV	150TB1	N5
	BAIL	15/25 kV	150TB2	N5
	BAIL	15/25 kV	150TB3	N5

Illustration (not to scale)	Description	Voltage Class	ELASTIMOLD Cat. No.	Notes
	BAIL	15/25 kV	150TB4	N5
	BAIL	15/25 kV	150TB5	N5
	Contacts: Long Bi-Metal Copper	15/25 kV 15/25 kV	02500X 02702X	N7
	Elbow Cable Entrance Insulating Plug	15/25 kV	10EP-W Use Table W6	N10
	Cable Entrance Insulating Plug	15/25 kV	152EA-W Use Table W6	N11
	Cable Size Adapter	15/25 kV	160CA-W Use Table W6 EB-FA Only	N14

- N1. Includes bail assembly.
- N2. W5X indicates that the Cat. No. includes a 02500X bi-metal compression lug, which is rated for either aluminum or copper conductor, as standard. For an all-copper lug, replace W5X with W2X in Table X1 to specify the all-copper 02702X lug.
- N3. Bails are required but not included. Order separately. Consult factory for bails not listed for a specific application.
- N4. Fully rotatable for 360° positioning. Includes bail assembly to secure feed-thru insert to bushing well. Elbows bail assemblies are required but not included with the feed-thru insert.
- N5. Refer to factory for application details.
- N6. Center-to-center spacing equals 4 in.
- N7. Copper lug for copper cable only.
- N8. To order cable legs for different cable sizes, list each leg size "W" and "X".
Example: K151LY-A1240-A1240-B1220. See Tables W1 and X1 for sizes.
- N9. To order locking contacts for K151LS and K151LY, order 01401X (Al) or 01402X (Cu) for plug contact.
Order 01301X (Al) or 01302X (Cu) for receptacle. See Table X1 for sizes.
- N10. For use with 156LR elbows.
- N11. For use with K151SR, K151SP, K151LS, K151LY receptacles, plugs and splices.
- N12. Also available as housing only. Specify K151BSP-W or K151BSR-W.
- N13. Also available in EB-FA sizes per table W6 by using 160CA cable adapter with C size plugs and receptacles.
- N14. 160CA cable adapter can only be used with C size plugs and receptacles.
- N15. Bails are not required for locking splices.
- N16. When used as a repair splice, the assembled length allows 4 in. for cable replacement/repair.
- N17. Straight receptacles are also available with test point. Specify K152SR-WOX Cat. No.
- N18. WOX indicates that the Cat. No. includes a 01500X universal aluminum compression lug, which is rated for either aluminum or copper, as standard. For an all-copper lug, replace WOX with W2X in Table X1 to specify the all-copper 01502X lug.
- N19. WOX indicates that the Cat. No. includes a 01600X universal aluminum compression lug, which is rated for either aluminum or copper, as standard. For an all-copper lug, replace WOX with W2X in Table X1 to specify the all-copper 01602X lug.
- N20. WOX indicates that the Cat. No. includes a 01400X universal aluminum compression lug, which is rated for either aluminum or copper, as standard. For an all-copper lug, replace WOX with W2X in Table X1 to specify the all-copper 01402X lug.
- N21. WOX indicates that the Cat. No. includes a 01300X universal aluminum compression lug, which is rated for either aluminum or copper, as standard. For an all-copper lug, replace WOX with W2X in Table X1 to specify the all-copper 01302X lug.
- N22. Direct Test Connectors, along with a 200TC-X series meter adapter, a properly rated voltage meter and Hot-line Stick provides a means for direct conductor voltage testing. See page A13 for meter adapters.
- N23. Gains approximately 4 in. of repair length.

Refer to the W and X tables on pages A39 to A41 for sizing to cable insulation diameter and conductor size. For cable shield adapters and jacket seals, see page A30.

600 Series Deadbreak

600 Series deadbreak elbows, straight receptacles, junctions, vault stretchers and accessories are used to connect equipment and cable on primary feeder and network circuits. Designs accommodate large conductors and feature bolted connections and deadfront modular construction for maximum reliability, performance and versatility.

DE-ENERGIZED connectors can be quickly and easily connected and disconnected using standard hand tools and equipment in accordance with accepted operating practices. Optional accessories allow visible external separation, by-pass, isolation, dead-ending, grounding, and testing as well as adding taps, surge arresters and circuit protection.

Hotstick operable and separable joint systems are shown on pages A16 thru A21.



Ratings Overview

See page A3–A4 for complete information.

Current Ratings

(Prefixes: 650, K650, K655, K656, 750, 755, 756 and 03700)

600 A Continuous
25 kA sym., 10 cycles

(Prefixes 675, K675, K676, 775, 776 and 03702)

900 A Continuous
25 kA sym., 10 cycles

Note: 900 A ratings require copper cable and copper current-carrying components.

VOLTAGE RATINGS

15/25 kV Class (5 kV thru 28 kV)

16.2 kV Phase-to-Ground

28 kV Phase-to-Phase

140 kV BIL

45 kV AC Withstand

84 kV DC Withstand

21.5 kV Corona Extinction

35 kV Class

21.1 kV Phase-to-Ground

36.6 kV Phase-to-Phase

150 kV BIL

50 kV AC Withstand

103 kV DC Withstand

26 kV Corona Extinction

Note: Elastimold has increased the IEEE Standard Production and Design Test levels for 25 kV Class products to include 27 kV and 28 kV systems.

SEPARABLE CONNECTORS 600 SERIES DEADBREAK

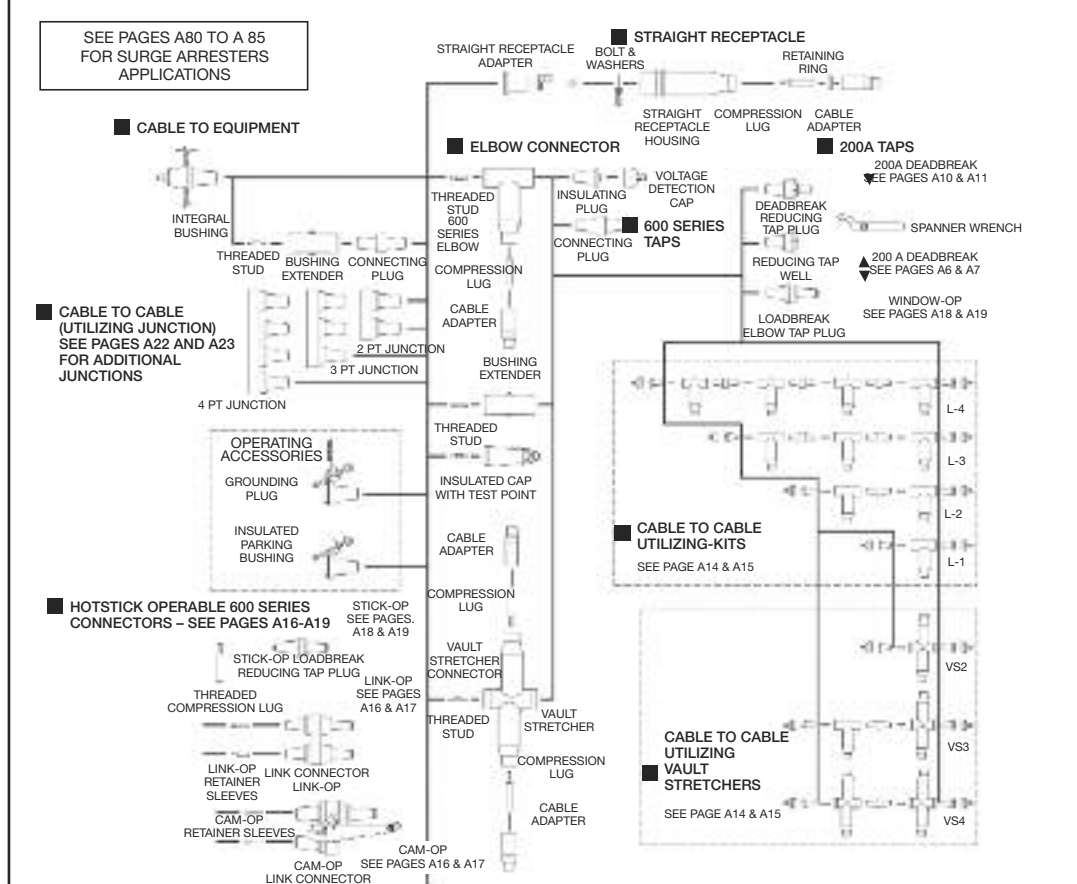

600 Series Deadbreak

Illustration (not to scale)	Description	Voltage Class	ELASTIMOLD Cat. No.	Notes
	600 Series Elbow (w/ Insul. Plug, Cap, Stud, Lug and Cable Adapter)	15/25 kV 35 kV	K655LR-WOX Use Tables W7 and X6 755LR-WOX Use Tables W9 and X6	N1, 2, 12 N1, 2, 12
	600 Series Direct Test Elbow (w/ Insul. Plug, Cap, Stud Lug and Cable Adapter)	15/25 kV 35 kV	K655DLR-WOX 755DLR-WOX	N1, 2, 12, 14 N1, 2, 12, 14
	600 Series Elbow w/ Test Point (w/ Insul. Plug, Cap, Stud Lug and Cable Adapter)	15/25 kV 35 kV	K656LR-WOX Use Tables W7 and X6 756LR-WOX Use Tables W9 and X6	N1, 2, 12 N1, 2, 12
	600 Series Direct Test Elbow w/ Test Point (w/ Insul. Plug, Cap, Stud, Lug and Cable Adapter)	15/25 kV 35 kV	K656DLR-WOX Use Tables W7 and X6 756DLR-WOX Use Tables W9 and X6	N1, 2, 12, 14 N1, 2, 12, 14
	600 Series Elbow Housing only (w/ Stud)	15/25 kV 35 kV	K655BLR 755BLR	N1, 3 N1, 3
	600 Series Elbow w/ Test Point Housing only (w/ Stud)	15/25 kV 35 kV	K656BLR 756BLR	N1, 3 N1, 3
	600 Series Replacement Elbow Housing only w/o Test Point	15/25 kV	K655BRLR	N16
	600 Series Replacement Elbow Housing only w/o Test Point	15/25 kV	K656BRLR	N16
	600 Series Straight Receptacle (w/ Cable Adapter, Lug and Retaining Ring)	15/25 kV	K655SR-WOX Use Tables W7 and X6	N1, 2, 11
	600 Series Direct Test Straight Receptacle Elbow	15/25 kV	K655DSR-WOX Use Tables W7 and X6	N1, 2, 11, 14
	600 Series Straight Receptacle Housing (Lug and Cable Adapter not included)	15/25 kV	K655BSR	N1, 11
	Straight Receptacle Adapter	15/25 kV	K650SRA	N1, 4
	600 Series Vault Stretcher (Housing only)	15/25 kV 35 kV	K655BVS 755BVS	N1, 9 N1, 9
	Cable Size Adapter	15/25 kV 35 kV	655CA-W Use Table W7 755CA-W Use Table W9	
	Compression Lug	ALL ALL	03700X Use Table X6 03702X Use Table X6	N5 N6
	600 Series Elbow and Vault Stretcher Size Sensitive Kit (Cable Adapter and Lug)	15/25 kV 35 kV	655CK-WOX Use Tables W7 and X6 755CK-WOX Use Tables W9 and X6	N2 N2
	Adapter Retaining Ring	ALL	650ARR-X Use Table X6	

Refer to the W and X tables on pages A39 to A41 for sizing to cable insulation diameter and conductor size. For cable shield adapters and jacket seals, see page A30.

Illustration (not to scale)	Description	Voltage Class	ELASTIMOLD Cat. No.	Notes
	600 Series Straight Receptacle Size Sensitive Kit (Cable Adapter, Retaining Ring and Lug)	15/25 kV	655CK-WOX-ARR Use Tables W7 and X6	N2
	Bushing Extender (w/ Stud)	15/25 kV 35 kV	K655BE 755BE	N1, 3 N1, 3
	Insulated Cap w/ Test Point (w/ Stud)	15/25 kV	K656DR	N3, 7
	Insulated Cap w/ Test Point (w/ Stud and Ground)	15/25 kV	K656DRG	N3, 7
	Insulating Plug (w/ Cap)	15/25 kV 35 kV	K650BIP 750BIP	N1, 7, 8 N1, 7, 8
	Grounding Plug (Ground Lead 2/0 AWG x 30 in.)	15/25 kV 35 kV	650GP 750GP	N1, 7, 8 N1, 7, 8
	Insulated Parking Bushing	15/25 kV 35 kV	K650SOP 750SOP	N7, 8 N7, 8
	Connecting Plug	15/25 kV 15/25 kV 35 kV	K650CP K651CP 750CP	N1, 7, 8, 9, 13 N1, 7, 8, 10 N1, 7, 8, 10
	Deadbreak Reducing Tap Plug	15/25 kV	K650RTP	N1, 7, 8, 9
	Reducing Tap Well	15/25 kV	K650RTW	N1, 7, 8, 9
	Loadbreak Elbow Tap Plug	15 kV 25 kV 35 kV	650ETP K650ETP 750ETP	N1, 7, 8, 10, 12 N1, 7, 8, 10, 12 N1, 7, 8, 10, 12
	Vault Stretcher Threaded Stud	15/25 kV 35 kV	650VSA 750VSA	N1 N1
	600 Series Elbow Threaded Stud	15/25 kV 35 kV	650SA 750SA	N1 N1
	Assembly Tool (Window-Op)	ALL	600ATM	N12
	Spanner Wrench	ALL	600SW	N9
	Direct Voltage Test Meter Adapter for: HD Electric Meters		200TC-1	N14
	Ross Meters	ALL	200TC-2	N14
	Chance Meters		200TC-4	N14

- N1. For 900 A ratings, substitute 675 for 650 and 655; 676 for 656; K671 for K651; K675 for K650 and K655; K676 for K656; 775 for 750 and 755; 776 for 756 and 2X for 0X in the Cat. No. The 900 A rating requires copper current-carrying connector components and copper conductor cable.
- N2. Add suffix symbol from page A29 to include cable shield grounding kit and/or cable jacket sealing kit.
- N3. Available without the stud by adding "N" to the Cat. No.
- N4. Straight Receptacle Adapter is used to connect Straight Receptacles K655YBSR and K655YSR-WOX (Page A19) to equipment bushings.
- N5. Aluminum lug for use on aluminum or copper conductors. DO NOT substitute threaded 03600X lug.
- N6. Copper lug for use on COPPER CONDUCTOR ONLY. DO NOT substitute threaded 03602X lug.
- N7. Available with the stud factory-assembled by adding "SP" to the Cat. No. 675ETP, K675ETP and 775ETP are available as -SP only. The stud is not field removable.
- N8. Available with a loose stud by adding suffix "S" to the Cat. No.
- N9. 600SW spanner wrench is recommended for installation of K650CP connecting plug, deadbreak reducing tap plugs and reducing tap wells.
- N10. Use 600ATM Assembly Tool.
- N11. 600 Series Elbows and Straight Receptacles with IEEE Std. 386 capacitive test points are available by substituting 656 for 655; K656 for K655; K676 for K675; 756 for 755; 676 for 675; K676 for K675 and 776 for 775 in the Cat. No.
- N12. See page A17 for Window-Op Connector Kit.
- N13. Superseded by K651CP.
- N14. Direct Test Connectors, along with a 200TC-X series meter adapter, a properly rated voltage meter and Hot-Line Stick; provides a means for direct conductor voltage testing.
- N15. With stainless steel bracket.
- N16. Replacement Elbow includes an I-Adapter, and Straight Receptacle, resulting in a net gain of 20 in.

600 Series Deadbreak

600 Series deadbreak elbows, straight receptacles, junctions, vault stretchers and accessories are used to connect equipment and cable on primary feeder and network circuits. Designs accommodate large conductors and feature bolted connections and deadfront modular construction for maximum reliability, performance and versatility.

DE-ENERGIZED connectors can be quickly and easily connected and disconnected using standard hand tools and equipment in accordance with accepted operating practices. Optional accessories allow visible external separation, by-pass, isolation, dead-ending, grounding, and testing as well as adding taps, surge arresters and circuit protection.

Hotstick operable and separable joint systems are shown on pages A16 thru A21.



Ratings Overview

See page A3–A4 for complete information.

Current Ratings

(Prefixes: 650, K650, K655, K656, 750, 755, 756 and 03700)

600 A Continuous
25 kA sym., 10 cycles

(Prefixes 675, K675, K676, 775, 776 and 03702)

900 A Continuous
25 kA sym., 10 cycles

NOTE: 900 A ratings require copper cable and copper current-carrying components.

Voltage Ratings

15/25 kV Class (5 kV thru 28 kV)

16.2 kV Phase-to-Ground

28 kV Phase-to-Phase

140 kV BIL

45 kV AC Withstand

84 kV DC Withstand

21.5 kV Corona Extinction

35 kV Class

21.1 kV Phase-to-Ground

36.6 kV Phase-to-Phase

150 kV BIL

50 kV AC Withstand







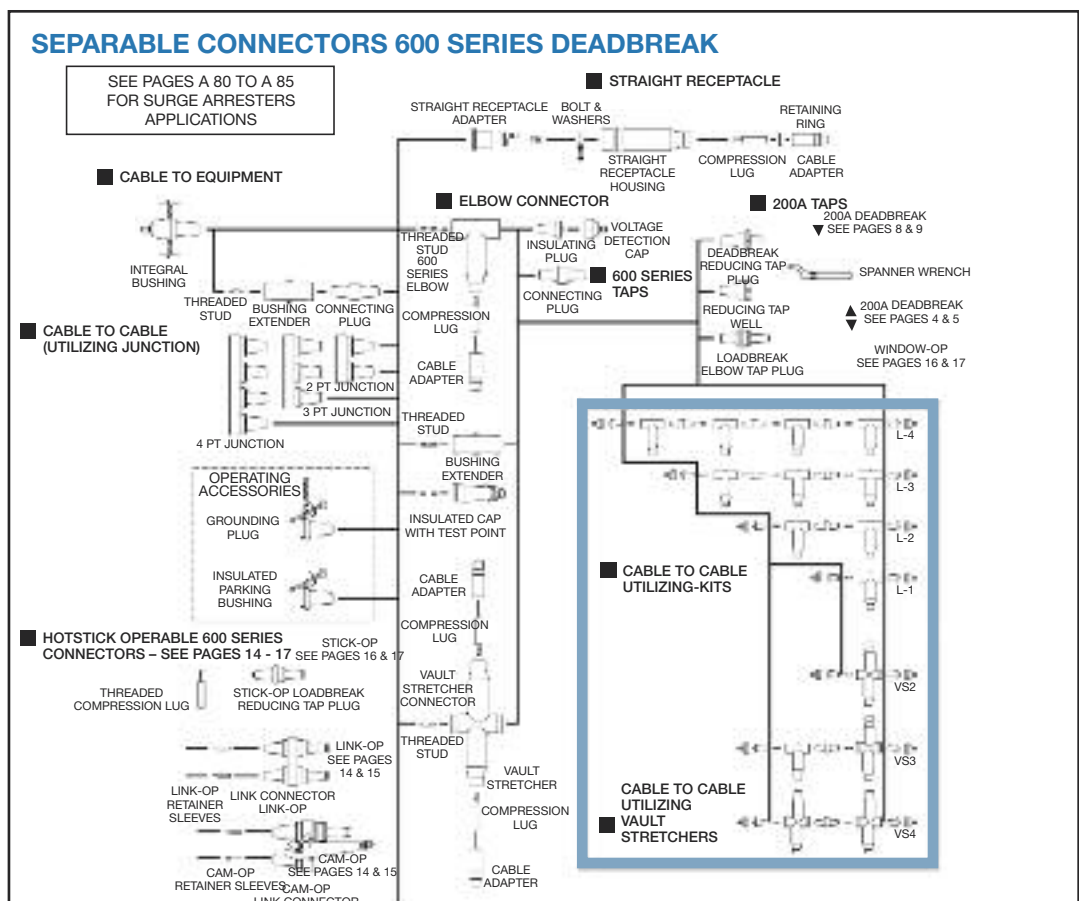

103 kV DC Withstand

26 kV Corona Extinction

Note: Elastimold has increased the IEEE Standard Production and Design Test levels for 25 kV Class products to include 27 kV and 28 kV systems.

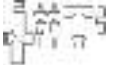
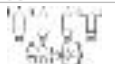
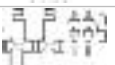

600 Series Deadbreak

Illustration (not to scale)	Description	Voltage Class	ELASTIMOLD Cat. No.	Notes
	2-Point Junction	15/25 kV 35 kV	K650J2 750J2	N1, 9, 10 N1, 9, 10
	3-Point Junction	15/25 kV 35 kV	K650J3 750J3	N1, 9, 10 N1, 9, 10
	4-Point Junction	15/25 kV 35 kV	K650J4 750J4	N1, 9, 10 N1, 9, 10
	1-way L-Kit	15/25 kV 35 kV	K655L1 755L1	N1, 2, 3, 4 N1, 2, 3, 4
	2-way L-Kit	15/25 kV 35 kV	K655L2 755L2	N1, 2, 3, 4, 5, 6, 7 N1, 2, 3, 4, 5, 6, 7
	2-way VS-Kit	15/25 kV 35 kV	K655VSL2 755VSL2	N1, 2, 3 N1, 2, 3
	3-way L-Kit	15/25 kV 35 kV	K655L3 755L3	N1, 2, 3, 4, 5 N1, 2, 3, 4, 5
	3-Way VS Kit	15/25 kV 35 kV	K655VSL3 755VSL3	N1, 2, 3, 5, 6, 7 N1, 2, 3, 5, 6, 7
	4-Way L-Kit	15/25 kV 35 kV	K655L4 755L4	N1, 2, 3, 4, 5 N1, 2, 3, 4, 5
	4-Way VS-Kit	15/25 kV 35 kV	K655VSL4 755VSL4	N1, 2, 3, 5 N1, 2, 3, 5
	Assembly Tool (Window-Op)	ALL	600ATM	N8
	Spanner Wrench	ALL	600SW	N2

- N1. For 900 A ratings, substitute 675 for 650 and 655; 676 for 656; K675 for K650 and K655; K676 for K656; 775 for 750 and 755; 776 for 756 and 2X for OX in the Cat. No. The 900 A rating requires copper current-carrying connector components and copper conductor cable.
- N2. 600SW spanner wrench is recommended for installation of K650CP connecting plug, deadbreak reducing tap plugs and reducing tap wells.
- N3. L-Kits and VS-Kits do not include cable adapters or compression lugs. These items must be ordered separately.
- N4. 600 Series Elbows and Straight Receptacles with IEEE Std. 386 capacitive test points are available by substituting 656 for 655; K656 for K655; K676 for K675; 756 for 755; 676 for 675; K676 for K675 and 776 for 775 in the Cat. No.
- N5. 600ATM is recommended for installing K651CP and 750CP.
- N6. Can be used as a repair joint. (Gains 3-1/2 in. of repair length)
- N7. Can be used as a reducing joint for different size cables.
- N8. See page A17 for Window-Op Connector Kit.
- N9. Rubber junction with stainless steel mounting plate and back plate.
Add "-U" for rubber junction with stainless steel mounting plate, back plate and adjustable mounting bracket.
Add "-4" for rubber junction only.
Add "-5" for rubber junction, stainless steel U-straps and back plate.
- N10. Two - six-position multi-point junctions shown on pages A20 and A21.



VAULT STRETCHER

Provides an alternate method of splicing and joining various types and styles of cables using standard 600 Series components.

Refer to the W and X tables on pages A39 to A41 for sizing to cable insulation diameter and conductor size. For cable shield adapters and jacket seals, see page A30.

600 Series Deadbreak – Cam-Op™, Link-Op™

Elastimold® 600 Series Cam-Op™, and Link-Op™ deadbreak connector systems incorporate provisions for hotstick operation of DE-ENERGIZED primary feeder or network circuits. Configurations allow external visible break, testing, grounding and isolation. Retrofit kits allow upgrading existing equipment.

Cam-Op systems utilize pin and socket connectors. Link-Op connectors are bolted and installed using torque controlled tools. Either system can be retrofitted to existing equipment.

The Cam-Op and Link-Op connectors are unique, allowing all hotstick operations to be completed without moving the cable, an important consideration when large, stiff cables prohibit movement.

The Cam-Op connector is easily installed or removed by hotstick operation of the cam action disconnect lever.



Ratings Overview

See page A3–A4 for complete information.

Current Ratings

600 and 900 A Continuous
25 kA sym., 10 cycles

NOTE: 900 A ratings require copper cable and copper current-carrying components.

Voltage Ratings

15 kV Class

8.3 kV Phase-to-Ground
14.4 kV Phase-to-Phase
95 kV BIL

34 kV AC Withstand
53 kV DC Withstand
11 kV Corona Extinction

25 kV Class

15.2 kV Phase-to-Ground
26.3 kV Phase-to-Phase
125 kV BIL

40 kV AC Withstand
78 kV DC Withstand
19 kV Corona Extinction

35 kV Class

21.1 kV Phase-to-Ground
36.6 kV Phase-to-Phase
150 kV BIL

50 kV AC Withstand
103 kV DC Withstand
26 kV Corona Extinction

CAM-OP™ and LINK-OP™ SYSTEM – 600 SERIES DEADBREAK

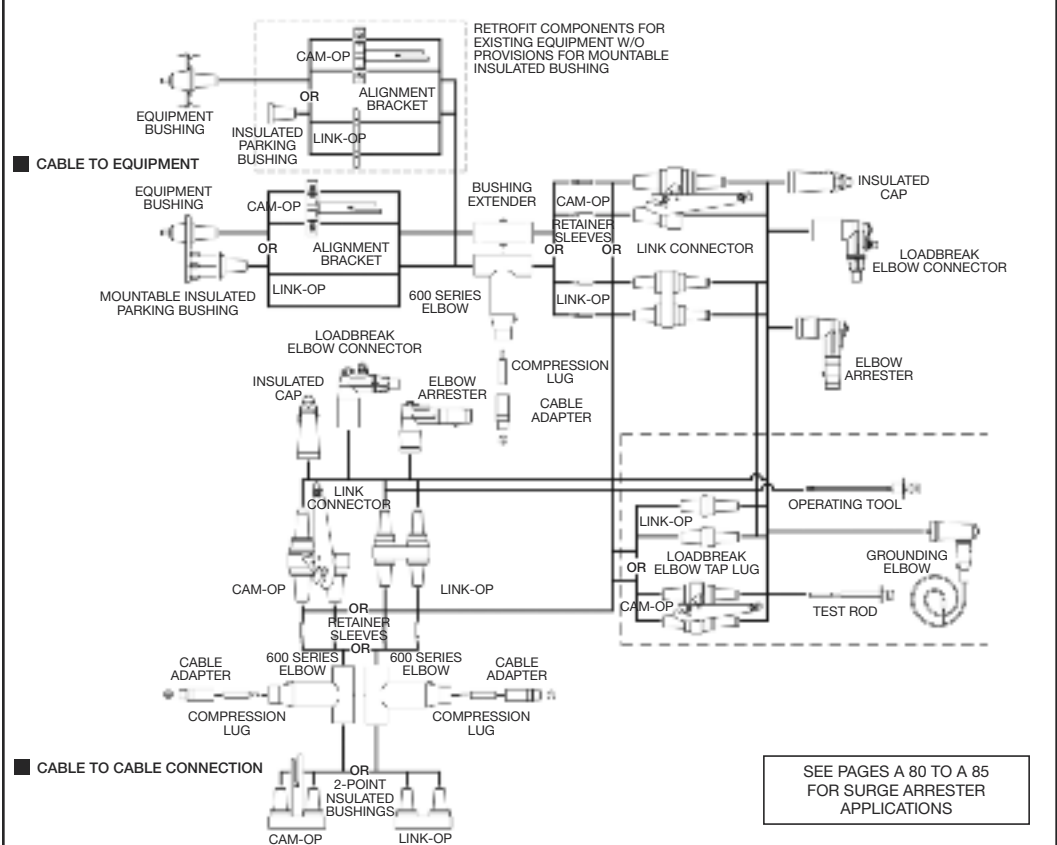

600 Series Deadbreak – Cam-Op™, Link-Op™

Illustration (not to scale)	Description	Voltage Class	ELASTIMOLD Cat. No.	Notes
	CAM-OP CONNECTOR KIT	15 kV 25 kV 35 kV	655LINK-C-LR-WOX-B-DRG Use Tables W7 and X6 K655LINK-C-LR-WOX-B-DRG Use Tables W7 and X6 755LINK-C-LR-WOX-B-DRG Use Tables W9 and X6	N1, 3, 11, 13, 14, 18 N1, 3, 11, 13, 14, 18 N1, 3, 11, 13, 14, 18
	LINK-OP CONNECTOR KIT	15 kV 25 kV 35 kV	655LINK-B-LR-WOX-B-DRG Use Tables W7 and X6 K655LINK-B-LR-WOX-B-DRG Use Tables W7 and X6 755LINK-B-LR-WOX-B-DRG Use Tables W9 and X6	N2, 3, 11, 12 13, 14, 18 N2, 3, 11, 13, 14, 18 N2, 3, 11, 13, 14, 18
	Mountable Insulated Bushing	25 kV 35 kV	K650LBM-3 750LBM-3	N3 N3
	RETROFIT CAM-OP CONNECTOR KIT	15 kV 25 kV 35 kV	655LINK-C-LR-WOX-A-DRG Use Tables W7 and X6 K655LINK-C-LR-WOX-A-DRG Use Tables W7 and X6 755LINK-C-LR-WOX-A-DRG Use Tables W9 and X6	N5, 11, 13 14, 18 N5, 11, 13 14, 18 N5, 11, 13 14, 18
	RETROFIT LINK-OP CONNECTOR KIT	15 kV 25 kV 35 kV	655LINK-B-LR-WOX-A-DRG Use Tables W7 and X6 K655LINK-B-LR-WOX-A-DRG Use Tables W7 and X6 755LINK-B-LR-WOX-A-DRG Use Tables W9 and X6	N6, 11, 12, 13, 14, 18 N6, 11, 12, 13, 14, 18 N6, 11, 12, 13, 14, 18
	Insulating Plug	25 kV 35 kV	K650LB 750LB	N4 N4
	CAM-OP Alignment Bracket	15 kV 25 kV 35 kV	650CAB K650CAB 750CAB	
	LINK-OP Alignment Bracket (Retrofit LINK-OP Only)	ALL ALL	650AB 650ABV	N15 N15
	Compression Lug	ALL ALL	03700X Use Table X6 03702X Use Table X6	N7 N8
	CAM-OP and LINK-OP Size Sensitive Kit (Cable Adapter and Lug)	15/25 kV 35 kV	655CK-WOX Use Tables W7 and X6 755CK-WOX Use Tables W9 and X6	N13 N13
	CAM-OP Retaining Sleeve	ALL	650RSC	N11
	LINK-OP Retaining Sleeve	ALL	650RS	N11
	CAM-OP CABLE JOINT KIT	15 kV 25 kV 35 kV	655BI-LINK-C-LR-WOX-DRG Use Tables W7 and X6 K655BI-LINK-C-LR-WOX-DRG Use Tables W7 and X6 755BI-LINK-C-LR-WOX-DRG Use Tables W9 and X6	N9, 11, 13 14, 18 N9, 11, 13 14, 18 N9, 11, 13 14, 18
	LINK-OP CABLE JOINT KIT	15 kV 25 kV 35 kV	655BI-LINK-B-LR-WOX-DRG Use Tables W7 and X6 K655BI-LINK-B-LR-WOX-DRG Use Tables W7 and X6 755BI-LINK-B-LR-WOX-DRG Use Tables W9 and X6	N10, 11, 12, 13, 14, 18 N10, 11, 12, 13, 14, 18 N10, 11, 12, 13, 14, 18

Refer to the W and X tables on pages A39 to A41 for sizing to cable insulation diameter and conductor size. For cable shield adapters and jacket seals, see page A30.

Illustration (not to scale)	Description	Voltage Class	ELASTIMOLD Cat. No.	Notes
	CAM-OP Loadbreak Reducing Tap Plugs (Visi-Break)	15 kV 25 kV 35 kV	650LK-C-VB K650LK-C-VB 750LK-C-VB	
	CAM-OP LINK	15 kV 25 kV 35 kV	650LK-C K650LK-C 750LK-C	
	LINK-OP Loadbreak Reducing Tap Plug	15 kV 25 kV 35 kV	650LT-B K650LT-B 750LT-B	N11
	Grounding Elbow (1/0 AWG x 6' Ground Lead)	15 kV 25 kV 35 kV	160GLR 370GLR 370GLR	N19 N19
	Test Rod	ALL	370TR	
	Assembly Tool	ALL	600AT	N11
	Cam-Op Operating Kit	15 kV 25 kV 35 kV	650CAM-OK K650CAM-OK 750CAM-OK	N16 N16 N16
	Link-Op Operating Kit	15 kV 25 kV 35 kV	650LINK-OK K650LINK-OK 750LINK-OK	N17 N17 N17

- N1. Cam-Op connector kit includes: 1- Cam-Op link; 1- elbow housing; 1- cable adapter; 1-0370 style lug; 1- bushing extender; 2- retainer sleeves; 1- insulated cap; 1- mountable insulated bushing and 1- alignment bracket.
- N2. Link-Op connector kit includes: 1- Link-Op link; 1- elbow housing; 1- cable adapter; 1-0370 style lug; 1- bushing extender; 2- retainer sleeves; 2- insulated caps; and 1- mountable insulated bushing.
- N3. Mountable insulated bushing included with Cam-Op and Link-Op connector kit. Requires 3 threaded studs on equipment faceplate for installation.
- N4. Use with the Retrofit Cam-Op and Retrofit Link-Op connector kit.
- N5. Retrofit Cam-Op connector kit includes: 1- link; 1- elbow housing; 1- cable adapter; 1-0370 style lug; 1- bushing extender; 2- retainer sleeves; 1- insulated cap; 1- insulating plug; and 1- alignment bracket.
- N6. Retrofit Link-Op connector kit includes: 1- link; 1- elbow housing; 1- cable adapter; 1-0370 style lug; 1- bushing extender; 2- retainer sleeves; 2- insulated caps; 1- insulating plug; and 1- alignment bracket.
- N7. Aluminum lug for use on aluminum or copper conductors. DO NOT substitute threaded 03600X lug
- N8. Copper lug for use on COPPER CONDUCTOR ONLY. DO NOT substitute 03602X threaded lug.
- N9. Cam-Op Cable Joint Kit includes: 1- Cam-Op link; 1- Cam-Op BI-SOP; 2- elbow housings; 2- cable adapters; 2- 0370 style lugs; 2- retainer sleeves; 1- insulated cap.
- N10. Link-Op Cable Joint Kit includes: 1- Link-Op link; 1- Link-Op BI-SOP; 2- elbow housings; 2- cable adapters; 2- 0370 style lugs; 2- retainer sleeves; 2- insulated caps.
- N11. 600AT assembly tool required for operation and/or installation of Link-Op. 600ATM is recommended for installing Link-Op/Cam-Op retaining sleeves.
- N12. For 900 A ratings, substitute 675 for 650 and 655; 676 for 656; K675 for K650 and K655; K676 for K656; 775 for 750 and 755; 776 for 756 and 2X for 0X in the Cat. No. The 900 A rating requires copper current-carrying connector components and copper conductor cable.
- N13. Add suffix symbol from page A29 to include cable shield grounding kit and/or cable jacket sealing kit.
- N14. To add elbows or arresters instead of insulating caps, replace the "DRG" with "LR-WX" for elbows (with test point) or "ESA" for elbow arresters.
- N15. The 650ABV is required when the bushing horizontal spacing on the equipment or junctions is less than 5".
- N16. Cam-Op operating kit includes accessories that enable visible break, testing, isolation and grounding functions to be performed. Kit includes: 3- Cam-Op loadbreak reducing tap plugs; 3- grounding elbows; 1- assembly tool; 1- test rod; 1- carry case; 1- lubricant; 1- instructions.
- N17. Link-Op operating kit includes accessories that enable visible break, testing, isolation and grounding functions to be performed. Kit includes: 6- Link-Op loadbreak reducing tap plugs; 3- grounding elbows; 1- assembly tool; 1- test rod; 1- carry case; 1- lubricant; 1- instructions.
- N18. 600 Series Elbows and Straight Receptacles with IEEE Std. 386 capacitive test points are available by substituting 656 for 655; K656 for K655; K676 for K675; 756 for 755; 676 for 675; K676 for K675 and 776 for 775 in the Cat. No.
- N19. Rated for both 25 kV and 35 kV applications.

600 Series Deadbreak – Stick-Op™, Window-Op™

Elastimold® 600 Series Window-Op™ and Stick-Op™ deadbreak connector systems incorporate provisions for hotstick operation of DE-ENERGIZED primary feeder or network circuits.

The Window-Op and Stick-Op connectors allow direct testing and grounding with no required cable movement.

Window-Op is ideal for equipment applications which include viewing windows to provide an internal visible break that does not require hotstick removal of the elbows.

Stick-Op provides an external visible break by hotstick removal of the elbow.

Window-Op and Stick-Op connectors are bolted and installed using torque controlled tools.

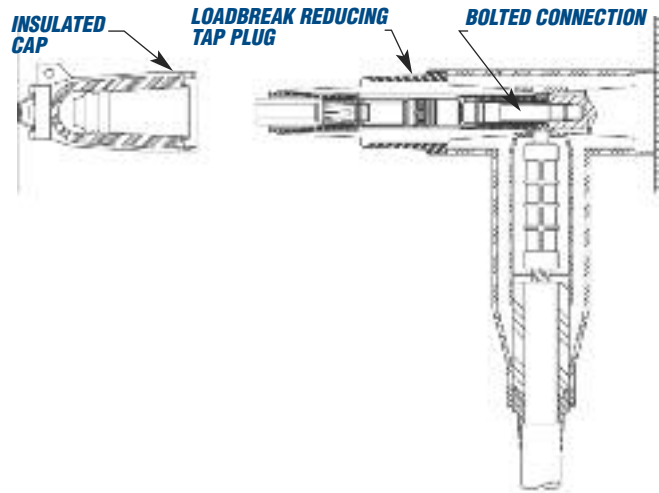

Ratings Overview

See page A3–A4 for complete information.

Current Ratings

600 and 900 A Continuous
25 kA sym., 10 cycles

NOTE: 900 A ratings require copper cable and copper current-carrying components.

Continuous Voltage Ratings

15 kV Class

8.3 kV Phase-to-Ground
14.4 kV Phase-to-Phase
95 kV BIL

34 kV AC Withstand
53 kV DC Withstand
11 kV Corona Extinction

25 kV Class

15.2 kV Phase-to-Ground
26.3 kV Phase-to-Phase
125 kV BIL

40 kV AC Withstand
78 kV DC Withstand
19 kV Corona Extinction

35 kV Class

21.1 kV Phase-to-Ground
36.6 kV Phase-to-Phase
150 kV BIL

50 kV AC Withstand
103 kV DC Withstand
26 kV Corona Extinction

STICK-OP™ and WINDOW-OP™ SYSTEM – 600 SERIES DEADBREAK

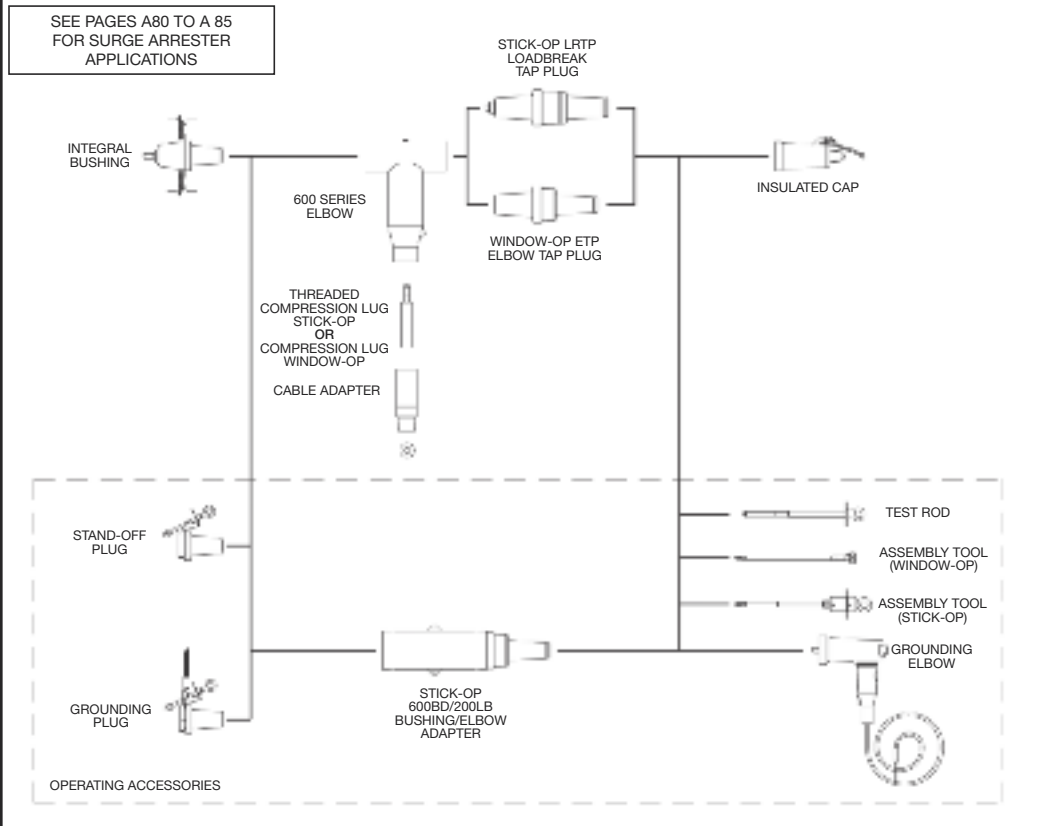

600 Series Deadbreak – Stick-Op™, Window-Op™

Illustration (not to scale)	Description	Voltage Class	ELASTIMOLD Cat. No.	Notes
	WINDOW-OP Connector Kit	15 kV 25 kV 35 kV	655ETP-WOX-DRG Use Tables W7 and X6 K655ETP-WOX-DRG Use Tables W7 and X6 755ETP-WOX-DRG Use Tables W9 and X6	N1, 4, 5, 6 13, 15
	WINDOW-OP Replacement Connector Kit	15 kV 25 kV	655RETP K655RETP	N4, 5, 6 8, 13
	STICK-OP Connector Kit	15 kV 25 kV 35 kV	655LRTP-WOX-DRG Use Tables W7 and X6 K655LRTP-WOX-DRG Use Tables W7 and X6 755LRTP-WOX-DRG Use Tables W9 and X6	N2, 3, 4, 5, 8, 13
	STICK-OP Replacement Connector Kit	15 kV 25 kV	655RLRTP K655RLRTP	N3, 4, 5 8, 13, 16
	WINDOW-OP Loadbreak Elbow Tap Plug	15 kV 25 kV 35 kV	650ETP K650ETP 750ETP	N4, 15 N4, 15 N4, 15
	STICK-OP Loadbreak Reducing Tap Plug	15 kV 25 kV 35 kV	650LRTPA3 K650LRTPA2 750LRTPA2	N3,4
	STICK-OP Bushing Adapter	15 kV 25 kV 35 kV	655BEA3 K655BEA2 755BEA2	N3,4
	Compression Lug WINDOW-OP	ALL	03700X Use Tables X6 03702X Use Tables X6	N6 N7
	Threaded Compression Lug STICK-OP	ALL	03600X Use Tables X6 03602X Use Tables X6	N8 N9
	WINDOW-OP Size Sensitive Kit (Cable Adapter and Lug)	15/25 kV 35 kV	655CK-WOX Use Tables W7 and X6 755CK-WOX Use Tables W9 and X6	N5 N5
	STICK-OP Size Sensitive Kit (Cable Adapter and Threaded Lug)	15/25 kV 35 kV	655TCK-WOX Use Tables W7 and X6 755TCK-WOX Use Tables W9 and X6	N5 N5
	Extraction Tool	ALL	650ET	N10
	Grounding Elbow (1/0 AWG x 6' Ground Lead)	15 kV 25 kV 35 kV	160GLR 370GLR 370GLR	N14 N14
	Test Rod	ALL	370TR	
	Assembly Tool (Stick-Op)	ALL	600AT	N3
	Assembly Tool (Window-Op)	ALL	600ATM	N15
	STICK-Op Operating Kit	15 kV 25 kV 35 kV	650STICK-OK K650STICK-OK 750STICK-OK	N11 N11 N11
	WINDOW-Op Operating Kit	15 kV 25 kV 35 kV	650WINDOW-OK K650WINDOW-OK 750WINDOW-OK	N12 N12 N12

- N1. Window-Op Kit includes: insulated cap; Window-Op reducing tap plug; 600 Series elbow housing; cable adapter; and 0370 style compression lug.
- N2. Stick-Op Kit includes insulated cap; Stick-Op Loadbreak reducing tap plug; 600 A Elbow Housing; cable adapter; and threaded 0360 style compression lug.
- N3. 600AT assembly tool required for operation and/or installation of Stick-Op.
- N4. For 900 A ratings, substitute 675 for 650 and 655; 676 for 656; K675 for K650 and K655; K676 for K656; 775 for 750 and 755; 776 for 756 and 2X for 0X in the Cat. No. The 900 A rating requires copper current-carrying connector components and copper conductor cable.
- N5. Add suffix symbol from page A29 to include cable shield grounding kit and/or cable jacket sealing kit.
- N6. Aluminum lug for use on aluminum or copper conductors. DO NOT substitute threaded 03600X lug.
- N7. Copper lug for use on COPPER CONDUCTOR ONLY. DO NOT substitute 03602X threaded lug.
- N8. Threaded aluminum lug (Stick-Op only) for use on copper or aluminum conductors. DO NOT substitute unthreaded 03700X lugs. DO NOT use with 675, 676, K675, K676, 775 or 776 Cat. Nos.
- N9. Threaded copper lug (Stick-Op only) for use on copper conductors only. DO NOT substitute unthreaded 03702X lugs.
- N10. Required to disassemble Stick-Op loadbreak reducing tap plug from the threaded compression lug and 600 Series elbow after the shear-pin is broken during assembly.
- N11. Stick-Op Operating Kit includes accessories that enable visible break direct testing, isolation, and grounding functions to be performed. Kit includes: 3-insulated parking bushings; 3-grounding elbows; 3-600DB/200LB bushing/elbow adapters; 1-assembly tool; 1-test rod; 1-carry case; 1-lubricant; 1-instructions.
- N12. Window-Op Operating Kit includes accessories that enable visible grounding and direct testing functions to be performed. Kit includes: 3-grounding elbows; 1-test rod; 1-carry case; 1-lubricant; 1-instructions.
- N13. 600 Series Elbows and Straight Receptacles with IEEE Std. 386 capacitive test points are available by substituting 656 for 655; K656 for K655; K676 for K675; 756 for 755; 676 for 675; K676 for K675 and 776 for 775 in the Cat. Nos.
- N14. Rated for both 25 kV and 35 kV applications.
- N15. 600ATM assembly tool required for Window-Op assembly. 50 – 60 ft./lb. torque wrench required but not included.
- N16. Replacement Elbow includes: insulated cap; reducing tap plug; 600 series elbow housing; I-Adapter; straight receptacle, resulting in a net gain of 20 in. length vs. a standard elbow kit. Compression lugs and cable adapters are ordered separately.

Refer to the W and X tables on pages A39 to A41 for sizing to cable insulation diameter and conductor size. For cable shield adapters and jacket seals, see page A30.

600 Series Deadbreak – Cable Joints

600 Series Separable Cable Joints are available in 2, 3 and 4-way versions and include a capacitive test point as standard. Units are interchangeable, featuring bolted connections. Designs are compact and ideally suited for small vaults and manholes.

DE-ENERGIZED joints can be quickly and easily connected and disconnected using standard hand tools and equipment in accordance with accepted operating practices. Bus bars can be changed to add or remove cables from the joint.

Optional accessories include insulating and grounding caps and plugs which allow visible external separation, by-pass, isolation, dead-ending, grounding and testing.



Ratings Overview

See page A3–A4 for complete information.

Current Ratings

(Prefixes: 650, K650, K655, K656 and 03700)

600 A Continuous
25 kA sym., 10 cycles

Voltage Ratings

15/25 kV Class (5 kV thru 28 kV)
16.2 kV Phase-to-Ground
28 kV Phase-to-Phase
140 kV BIL
45 kV AC Withstand
84 kV DC Withstand
21.5 kV Corona Extinction

Note: Elastimold has increased the IEEE Standard Production and Design Test levels for 25 kV Class products to include 27 kV and 28 kV systems.

SEPARABLE CABLE JOINTS – 600 SERIES DEADBREAK

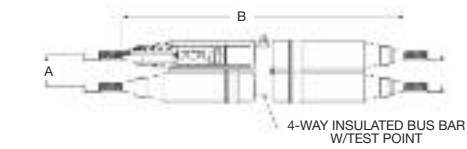

**SEPARABLE H-JOINT
(4-WAY)**

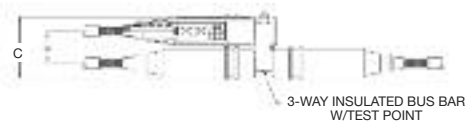

**SEPARABLE WYE-JOINT
(3-WAY)**

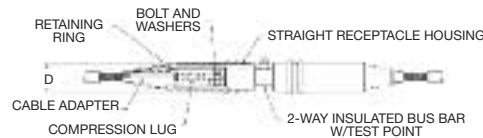

**SEPARABLE STRAIGHT-JOINT
(2-WAY)**

OPERATING ACCESSORIES

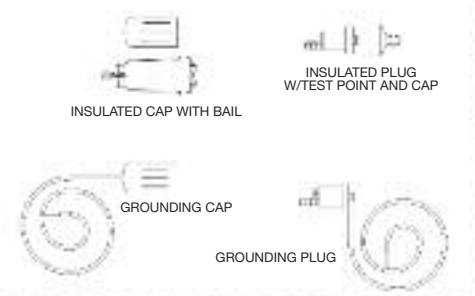

Note: The separable cable joints shown here use a special “Y” interface that may not be interchangeable with other 600 Series interfaces.

Dimension	(in.)
A	4-1/4
B	37-1/8
C	8-1/8
D	3-7/8

600 Series Deadbreak – Cable Joints

Illustration (not to scale)	Description	Voltage Class	ELASTIMOLD Cat. No.	Notes
	Separable Straight Joint Pkg. (2-way) w/ Test Point	15/25 kV	K656I-WOX Use Tables W7 and X6	N1, 8
	Basic Housing Pkg. Straight Joint w/ Test Point	15/25 kV	K656I-HP N2	N2
	Separable Wye Joint Pkg. (3-Way) w/ Test Point	15/25 kV	K656CY-WOX Use Tables W7 and X6	N1, 8
	Basic Housing Pkg. Wye Joint w/ Test point	15/25 kV	K656CY-HP	N2
	Separable "H" Joint Pkg. (4-Way) w/ Test Point	15/25 kV	K656CH-WOX Use Tables W7 and X6	N1, 8
	Basic Housing Pkg. "H" Joint w/ Test Point	15/25 kV	K656CH-HP	N2
	2-Way Insulated Bus Bar w/Test Point	15/25 kV	K656I-BUS	N3
	3-Way Insulated Bus Bar w/Test Point	15/25 kV	K656CY-BUS	N3
	4-Way Insulated Bus Bar w/Test Point	15/25 kV	K656CH-BUS	N3
	Straight Receptacle	15/25 kV	K655YSR-WOX Use Tables W7 and X6	N4, 8
	Direct Test Straight Receptacle Elbow	15/25 kV	K655YDSR-WOX Use Tables W7 and X6	N4, 8, 11
	Direct Test Straight Receptacle Elbow w/ Test Point	15/25 kV	K656YDSR-WOX Use Tables W7 and X6	N4, 8, 11
	Straight Receptacle Housing Only	15/25 kV	K655YBSR	N5, 10
	Insulated Ca w/ Bail	15/25 kV	K655YDR	
	Bail Only	15/25 kV	650BA	
	Cable Adapter	15/25 kV	655CA-W Use Table W7	
	Adapter Retaining Ring	15/25 kV	650ARR -X Use Table X6	
	Compression Lug	15/25 kV 15/25 kV	03700X N7 03702X N9 Use Table X6	N7 N9

Illustration (not to scale)	Description	Voltage Class	ELASTIMOLD Cat. No.	Notes
	600 Series Straight Receptacle Size Sensitive (Cable Adapter, Retaining Ring and Lug)	15/25 kV	655CK-WOX-ARR Use Tables W7 and X6	N8
	Insulating Plug w/ Test Point and Cap	15/25 kV	K650YBIP	
	Grounding Plug (4/0 AWG x 6' Ground Lead)	15/25 kV	650YGP	
	Grounding Cap (4/0 AWG x 6' Ground Lead)	15/25 kV	650GYDR	
	Stainless Steel Bolt and Washers	15/25 kV	650BAW	
	Assembly Disassembly Tool	ALL	600YADT-1 N6	N6
	Assembly Disassembly Tool	ALL	600RR T N6	N6

- N1. Complete Joint Packages consisting of: insulated bus bar; straight receptacle housings, retaining rings, cable size adapters, lugs, bolts and washers.
- N2. Housing Packages consisting of the following non-size sensitive components of the joint: insulated bus bar, straight receptacle housings, bolts and washers.
- N3. Insulated bus bar only.
- N4. Straight Receptacle consisting of: straight receptacle housing, retaining ring, cable adapter, lug, bolt and washers.
- N5. Straight receptacle housing consisting of: straight receptacle housing, bolt and washers.
- N6. Recommended for ease of assembly/disassembly of receptacles to Bus. 600 YADT is lever drive and 600RRT is screw drive.
- N7. Aluminum lug for use on aluminum or copper conductors. DO NOT substitute threaded 03600X lug.
- N8. Add suffix symbol from page A29 to include cable shield grounding kit and/or cable jacket sealing kit.
- N9. Copper lug for use with COPPER CONDUCTOR ONLY. DO NOT substitute threaded 03602X lug.
- N10. Available without the bolt and washers by adding "N" to the Cat. No.
- N11. Direct Test Connectors, along with a 200TC-X series meter adapter, a properly rated voltage meter and Hot-line Stick; provides a means for direct conductor voltage testing. See page A13 for meter adapters.

Refer to the W and X tables on pages A39 to A41 for sizing to cable insulation diameter and conductor size. For cable shield adapters and jacket seals, see page A30.

Molded Multi-Point Junctions

Elastimold® multi-point junctions are available in 2, 3, 4, 5 or 6 point configurations with 15, 25 or 35 kV ratings. Units feature modular design flexibility, allowing selection of any combination of 200 A deepwell or 600 A bushing interfaces located on standard 4 in. or optional 6 1/2 in. centers. The 6 1/2 in. center spacing is especially well suited for Distributed Switchgear applications including fused elbow, MVI fault interrupter, MVS switch, etc.

Designs incorporate lightweight, damage resistant, EPDM molded rubber construction and corrosion resistant 304 stainless steel mounting brackets. Junctions are maintenance-free, fully shielded, deadfront and submersible. Units are ideally suited for subsurface, padmount, indoor and outdoor vault applications.

Elastimold multi-point junctions provide a convenient method for connecting, looping and tapping of 200 and 600 A elbows and other accessories at a common location where utilization of space, cable training, flexibility and operability are important.

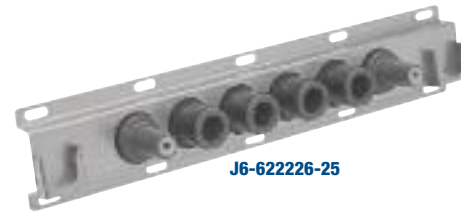

J6-622226-25



J6-662266-25-SV

Ratings Overview

See page A3–A4 for complete information.

Current Ratings

600 A Continuous
25 kA sym., 10 cycles
or with 200 A Bushing Well versions
200 A Continuous
10 kA sym., 10 cycles

Voltage Ratings

15 kV Class
8.3 kV Phase-to-Ground
95 kV BIL
34 kV AC Withstand
53 kV DC Withstand
11 kV Corona Extinction

25 kV Class
16.2 kV Phase-to-Ground
140 kV BIL
45 kV AC Withstand
84 kV DC Withstand
21.5 kV Corona Extinction

35 kV Class
21.1 kV Phase-to-Ground
150 kV BIL
50 kV AC Withstand
103 kV DC Withstand
26 kV Corona Extinction

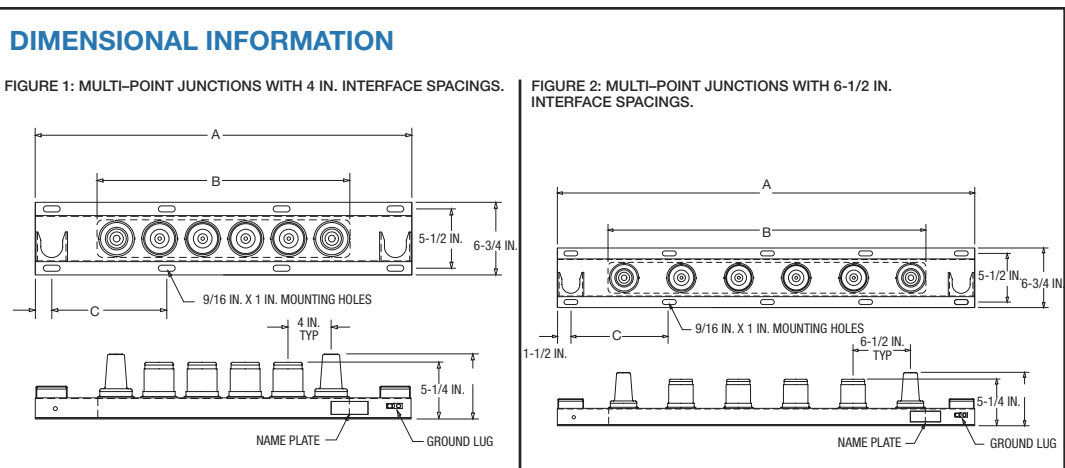

Type of Junction	Figure 1				Figure 2			
	A	B	C	Number of mounting holes	A	B	C	Number of mounting holes
J2	15	7-1/2	6	6	19-1/2	10	8-1/4	6
J3	19	11-1/2	8	6	26	10	11-1/2	6
J4	24	15-1/2	10	6	32-1/2	23	9-1/4	8
J5	27	19-1/2	12	6	39	10	12	8
J6	31	23-1/2	9-3/8	8	45-1/2	36	8-1/4	10

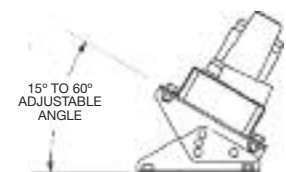



Optional Tilt Mounting Adapter.

Molded Multi-Point Junctions

Elastimold® multi-point junctions feature modular design flexibility that permits the specifier to determine the positions of the bushing interfaces and bushing well positions.

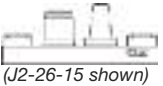
Base Catalogue Numbers

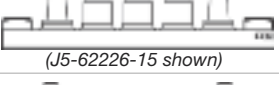
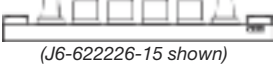
Installation (not to scale)	Description	Voltage Class	Elastimold Cat. No.		Notes
			4 in. Spacing	6-1/2 in. Spacing	
 (J2-26-15 shown)	2- point Junction	15 kV 25 kV 35 kV	J2 - ____ - 15 J2 - ____ - 25 J2 - ____ - 35	J2 - ____ - 15-SV J2 - ____ - 25-SV J2 - ____ - 35-SV	N1, 2
 (J3-626-35 shown)	3- point Junction	15 kV 25 kV 35 kV	J3 - _____ - 15 J3 - _____ - 25 J3 - _____ - 35	J3 - _____ - 15-SV J3 - _____ - 25-SV J3 - _____ - 35-SV	N1, 2
 (J4-6226-15 shown)	4- point Junction	15 kV 25 kV 35 kV	J4 - _____ - 15 J4 - _____ - 25 J4 - _____ - 35	J4 - _____ - 15-SV J4 - _____ - 25-SV J4 - _____ - 35-SV	N1, 2
 (J5-62226-15 shown)	5- point Junction	15 kV 25 kV 35 kV	J5 - _____ - 15 J5 - _____ - 25 J5 - _____ - 35	J5 - _____ - 15-SV J5 - _____ - 25-SV J5 - _____ - 35-SV	N1, 2
 (J6-622226-15 shown)	6- point Junction	15 kV 25 kV 35 kV	J6 - _____ - 15 J6 - _____ - 25 J6 - _____ - 35	J6 - _____ - 15-SV J6 - _____ - 25-SV J6 - _____ - 35-SV	N1, 2

ORDERING INFORMATION

To specify and order Elastimold Multi-Point Junctions:

1. Use Table 1 to construct a catalogue number describing the required junction.

Table 1. Catalogue Number Construction

J	-	-	-	-	-
Multi-Point Junction	Number of Points	Interface Identification * and Positioning	Voltage Class	Interface Spacing	Options
	2 2 Points	2 200 A Deepwell Interface	15 15 kV	Blank Standard spacing – 4 in. centers	Blank No tilt mounting bracket
	3 3 Points	6 600 A Bushing Interface	25 25 kV	SV Optional 6-1/2 in.centers	TMA Tilt Mounting Adapter. Bolts to the bottom of the standard mounting bracket to provide 15, 30, 45 or 60 degree adjustable angle mounting. (Two Tilt Mounting Adapters are required for each installation.)
	4 4 Points	B Blank Position	35 35 kV		L Left parking stand only
	5 5 Points				R Right parking stand only
	6 6 Points				N No parking stand

*When there is a 200 A Interface on one side of the junction and a 600 Series Interface on the other side, always start with the 200 A side.

Ordering Example A

To order a 4-point, 15 kV junction with 4 in. spacings and 600 Series interfaces on the outside ways and 200 A wells on the inside ways specify: Catalogue Number J4-6226-15

Ordering Example B

To order a 6-point, 25 kV junction with 6-1/2 in. spacings and 600 Series interfaces on the ways 1, 3, 4, 6 and 200 A wells on the ways 2 and 5 specify: Catalogue Number J6-626626-25-SV

N1. The 6-1/2 in.wide spacing is necessary if the junction is to be used to connect with a single-phase MVS Molded Vacuum Switch or MVI Molded Vacuum Interrupter.
N2. Also available with a shorter bracket by reducing the number of parking stands, see R, L, N above.

PCJ™ Power Cable Joints

PCJ™ Power Cable Joints utilize permanently crimped connectors. PCJ Housings are fully insulated, shielded and sealed for direct buried, vault, submersible and other severe service applications. Units have been designed and tested per IEEE Standard 404 to assure system matched performance and ratings equal to the cable to which the splice will be installed.

PCJ Power Cable Joints are available in 2 styles:

Style 1 uses a single piece housing that is sized to accommodate a specific range of cable. Style 1 units are ideally suited for straight splicing of the same or similar cable.

Style 2 designs incorporate a universal housing with separate cable adapters to allow transition splices of different types and sizes of cable.



ELECTRICAL RATINGS SUMMARY

The following ratings summary is based on **IEEE Std. 404** and applies to all Elastimold PCJ Power Cable Joints.

Voltage

- A. 15 kV Class (8.7 kV Phase-to-Ground)
- B. 25 kV Class (14.4 kV Phase-to-Ground)
- C. 35 kV Class (20.2 kV Phase-to-Ground)

- **Impulse Withstand:** A=110 kV, B=150 kV, C=200 kV BIL, 1.2 x 50 microsecond wave
- **Corona Extinction Voltage:** A=13 kV, B=22 kV, C=30 kV minimum, 3pC sensitivity
- **DC Withstand:** During installation: A=56 kV, B=80 kV, C=100 kV
- **DC Withstand:**

After installation and in service for the first 5 years:

A=18 kV, B=25 kV, C=31 kV for XLPE Insulated Cables
and A=45 kV, B=64 kV, C=80 kV for EPR Insulated Cables
(Reference AEIC CS6 and CS8, Section L.2.)

Current

- Continuous rating equal to the rating of the cable
- Short-Time rating equal to the rating of the cable up to 35 kA

Shield Design

- Meets IEEE standard 592 for Exposed Semiconducting Shields on Premolded High Voltage Cable Joints and Separable Insulated Connectors

Production tests include 100% tests of the premolded joints to assure:

- **Corona Extinction Voltage:** A=13 kV, B=22 kV, C=30 kV minimum, 3pC sensitivity
- **AC Withstand:** A=35 kV, B=52 kV, C=69 kV, 60 Hz, 1 minute

Design tests on production joints demonstrate compliance with IEEE 404 including:

- **Corona Extinction Voltage:** A=13.0 kV, B=22.0 kV, C=30.0 kV minimum, 3pC sensitivity
- **AC Withstand:** A=35 kV, B=52 kV, C=69 kV, 60 Hz 1 minute.
- **DC Withstand:** A=70 kV, B=100 kV, C=125 kV negative polarity, 15 minutes
- **Impulse Withstand (BIL):** A=110 kV, B=150 kV, C=200 kV, 10 positive and 10 negative, 1.2 x 50 microsecond wave, at conductor temperatures of 20° and 130°C, nominal
- **Short-Time Current:** magnitude equal to cable up to 35 kA
- **Cyclic Aging:** 30 days at: A=26.1 kV, B=43.2 kV, C=60.6 kV AC continuous, load current for 8 hours per day, providing 130° conductor temperature. Joints then subjected to: A=31 kV, B=50 kV, C=71 kV for 5 hours followed by: A=39 kV, B=65 kV, C=91 kV for 5 min.
- **Load Cycle:** Connectors meet requirements of ANSI C119.4, Class A and Class 3 ratings

PCJ™ Power Cable Joints

PCJ Style 1
with single-piece housing



PCJ Style 2
with universal housing and separate cable adapters
that can be varied with the cable application.

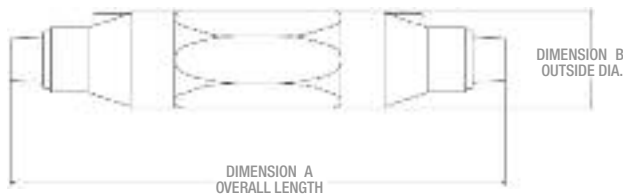
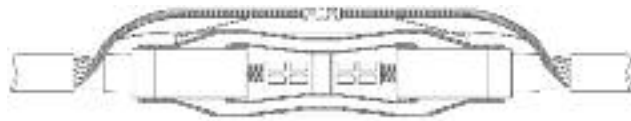

ORDERING INFORMATION

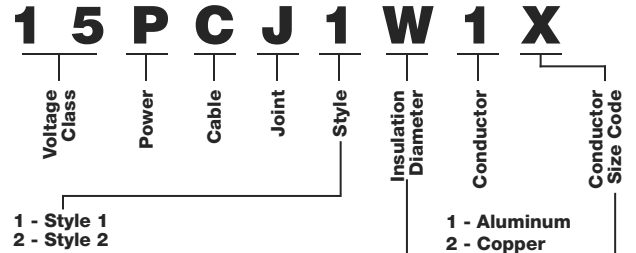

W SIZING INFORMATION AND SELECTION

Use Table W8 for 15PCJ
 Use Table W9 for 25PCJ
 Use Table W10 for 35PCJ

X SIZING INFORMATION AND SELECTION

Use Table X7 for 15PCJ, 25PCJ and 35PCJ

DIMENSIONAL DATA

Style 1 Cat. No.	A (in.)	B (in.)
15PCJ1FX	10-1/4	1-3/4
15PCJ1GX	10-1/4	1-3/4
25PCJ1GX	14-3/8	2-7/16
15/25/35PCJ1HX	14-3/8	2-7/16
15/25/35PCJ1JX	14-3/8	2-7/16
15/25/35PCJ1KX	14-3/8	2-25/32
15/25/35PCJ1LX	14-3/8	2-25/32
15/25PCJ1LMX	14-3/8	2-25/32
15/25/35PCJ1MX	14-3/8	2-25/32
15/25/35PCJ1NX	15-3/4	3-3/16
15/25/35PCJ1PX	15-3/4	3-3/16
15/25/35PCJ1QX	15-3/4	3-3/16

Style 2 Cat. No.	A (in.)	B (in.)
15PCJ2FX	16-3/8	2-25/32
15/25PCJ2GX	16-3/8	2-25/32
15/25/35PCJ2HX	16-3/8	2-25/32
15/25/35PCJ2JX	16-3/8	2-25/32
15/25/35PCJ2KX	21	3-3/4
15/25/35PCJ2LX	21	3-3/4
15/25/35PCJ2MX	21	3-3/4
15/25/35PCJ2NX	21	3-3/4
15/25/35PCJ2PX	21	3-3/4
15/25/35PCJ2QX	21	3-3/4

Description	Voltage Class	ELASTIMOLD Cat. No.	Notes
Power Cable Joint Style 1	15 kV	15PCJ1W1X	N1
	15 kV	15PCJ1W2X	N2
	25 kV	25PCJ1W1X	N1
	25 kV	25PCJ1W2X	N2
	35 kV	35PCJ1W1X	N1
	35 kV	35PCJ1W2X	N2
Power Cable Joint Style 2	15 kV	15PCJ2W1X	N1
	15 kV	15PCJ2W2X	N2
	25 kV	25PCJ2W1X	N1
	25 kV	25PCJ2W2X	N2
	35 kV	35PCJ2W1X	N1
	35 kV	35PCJ2W2X	N2

N1. Kit includes aluminum compression connector suitable for splicing aluminum conductor to aluminum conductor or aluminum conductor to copper conductor. An all-copper connector is required for copper-to-copper connections.

N2. Kit includes copper compression connector suitable for splicing copper conductors to copper conductor only. DO NOT use copper connectors on aluminum conductors.

Refer to the W and X tables on pages A39 to A41 for sizing to cable insulation diameter and conductor size. For cable shield adapters and jacket seals, see page A30.

Cable Terminations

Elastimold® cable terminations are available in single piece or modular designs. Terminators allow connection and transition from shielded, underground cable to bare overhead conductors and live-front equipment. Units are designed and rated per IEEE Standard 48 for riser pole, padmount, indoor and outdoor applications. PCT1, PCT2, 16THG and 35MTG terminators provide sufficient creep, strike and weather sealing for class 1 outdoor service. PCT1 and PCT2 also include an integral cable jacket seal.

The 35MTGI terminators and 35MSC stress cones are rated for class 2 and class 3 indoor service respectively. Optional mounting brackets, aerial lugs and equipment connectors are available as required.



Electrical Ratings Summary

The following ratings summary is based on IEEE Std. 48 and applies to all the terminations on pages A26 thru A29. Elastimold terminations are designed for use on three-phase systems, either 3-wire or 4-wire and the single-phase laterals of these systems.

Voltage Ratings

15 kV Class

9.5 kV Phase-to-Ground
110 kV BIL 1.2 x 50 microsecond wave
AC Withstand:

- 50 kV 1 min. – dry
- 35 kV 6 hr. – dry
- 45 kV 10 sec. – wet
- 13 kV Corona Extinction

25 kV Class

16 kV Phase-to-Ground
150 kV BIL 1.2 x 50 microsecond wave
AC Withstand:

- 65 kV 1 min. – dry
- 55 kV 6 hr. – dry
- 60 kV 10 sec. – wet
- 21.5 kV Corona Extinction

35 kV Class

22 kV Phase-to-Ground
200 kV BIL 1.2 x 50 microsecond wave
AC Withstand:

- 90 kV 1 min. – dry
- 75 kV 6 hr. – dry
- 80 kV 10 sec. – wet
- 30 kV Corona Extinction

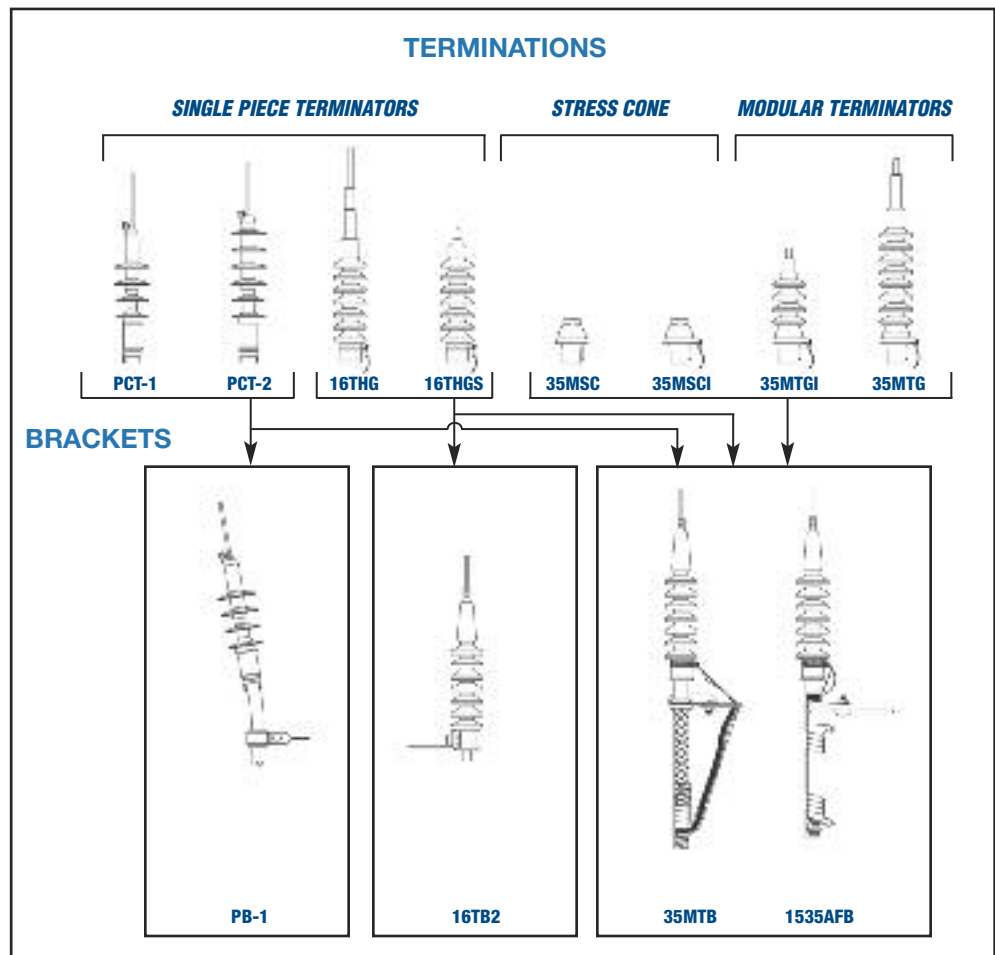

Cable Terminations

Illustration (not to scale)	Description	Voltage Class	ELASTIMOLD Cat. No.	Notes
	Single-Piece Terminator (Class 1)	15 kV 25 kV	PCT1-1X-4 Use Table X9 PCT2-1X-4 Use Table X9	N12, 14, 15, 22 N12, 14, N15, 23
	Housing only	15 kV 25 kV	PCT1-4 PCT2-4	N13,22 N13,23
	Single-Piece Terminator (Class 1)	15/25 kV	16THG-WOX-4 Use Tables W12 and X8	N2, 14 15
	Housing only	15/25 kV	16THGH-W Use Table W12	
	Single-Piece Terminator for solid conductor only (Class 1)	15/25 kV	16THGS-WX Use Tables W12 and X4	N3
	Stress Cone (Class 3)	ALL	35MSC-W Use Table W11	N17
	Stress Cone w/Grd. Strap	ALL	35MSCI-W Use Table W11	N17
	Modules only	ALL	35MG-W Use Table W13	N11, 16
	Modular Terminator (Class 1)	15 kV	35MTG-WX-4-CA Use Tables W13 and X3	N2, 11
		25 kV	35MTG-WX-8-CA Use Tables W13 and X3	N2, 5, 11
		35 kV	35MTG-WX-10-CA Use Tables W13 and X3	N2, 6, 11
	Modular Terminator (Class 2) w/o Rain Cap	15 kV	35MTGI-W-4 Use Table W13	N11
		25 kV	35MTGI-W-6 Use Table W13	N11
		35 kV	35MTGI-W-8 Use Table W13	N7, 11
	Rod Contact for PCT	15/25 kV	00700X Use Table X9	N1, 14, 15
	Rod Contact for 16THG	15/25 kV	16TCA-X Use Table X8	N2, 8
	Solid Conductor Package for 16THGS	15/25 kV	16CAS-X Use Table X4	N3, 9
	3/4 in.-16 Threaded Rod for MTG	ALL	35MTGA-WX-1 Use Tables W13 and X3	N2, 10, 11 18, 25
	1 in.-14 Threaded Rod for MTG	ALL	35MTGA-WX-2 Use Tables W13 and X3A	N2, 10, 11 19, 25
	Two-Hole Spade for MTG	ALL	35MTGA-WX-3 Use Tables W13 and X3	N4, 10, 11 20, 25
	Two-Hole Spade for PCT	ALL	01000X Use Table X9	N1
	One-Hole Spade for PCT	ALL	01100X Use Table X9	N1
	Universal Rod for MTG	ALL	35MTGA-WX-4 Use Tables W13 and X3	N2, 10, 11 21, 25
	Aerial Lugs for MTG Threaded Rod (Two-hole spade or bare wire)	ALL	35AL-A	N10, 24

- N1. Use with PCT1 or PCT2 Terminators.
- N2. Includes contact rod, ground strap and rain cap.
- N3. Includes crimp ring, ground strap and rain cap.
- N4. Includes spade contact, ground strap and rain cap.
- N5. For KA thru PB sizes use 35MTG-WX-6-CA.
- N6. For KA thru PB sizes use 35MTG-WX-8-CA.
- N7. For KA thru PB sizes use 35MTGI-W-6.
- N8. Use with 16THG Terminators.
- N9. Use with 16THGS Terminators.
- N10. Use with 35MTG Terminators.
- N11. Refer to page A26 for detailed ordering instructions.
- N12. Includes rod contact as standard. Specify suffix "-3" in place of "-4" for two-hole spade lug. Specify suffix "-5" in place of "-4" for one-hole spade lug.
- N13. Specify suffix "-3" or "-5" in place of "-4" for two-hole spade lug housing or one-hole spade style housing.
- N14. Use 1X for an aluminum rod contact for aluminum conductors only.
- N15. Substitute OX for 1X for a universal aluminum rod contact for aluminum or copper conductors.
- N16. Available in sizes from GA thru PB and are supplied qty. 2 per package.
- N17. Available in sizes EB thru PB.
- N18. For conductors from 1/0 thru 350 kcmil.
- N19. For conductors from 400 kcmil thru 1000 kcmil.
- N20. For conductors from #2 to 1000 kcmil.
- N21. For conductors from #6 thru 4/0.
- N22. Use for insulation dia. range from .640 in. thru 1.070 in.
- N23. Use for insulation dia. range from .830 in. thru 1.180 in.
- N24. Select symbol for "A" from aerial lug ordering information on page A28.
- N25. W13 Table provides sizing for rain cap. X10 Table provides sizing for connectors.

Refer to the W and X tables on pages A39 to A41 for sizing to cable insulation diameter and conductor size. For cable shield adapters and jacket seals, see page A30.

Cable Terminations

ORDERING INSTRUCTIONS FOR MODULAR TERMINATORS

35MTG - W X - N - C A

I - Indoor
Blank = Outdoor

Use Table W13, below

Use Table X3 or Table X3A

NOTE: Applicable table and available sizes depend upon connector style. Reference Connector Style Selection Chart and notes A through D.

Recommended Number of Modules

	GA-JB	KA-PB
15 kV	4	4
25 kV	8	8
35 kV	10	10

Connector Style Selection Chart

Description	Available for Conductor Sizes	Symbol	Notes
3/4 in.-16 Threaded Rod	1/0 thru 350 kcmil	-1	A
1 in.-14 Threaded Rod	400 thru 1000 kcmil	-2	B
2-Hole Spade	#2 thru 1000 kcmil	-3	C
Universal Rod	#6 thru 4/0	-4	D

Aerial Lugs for Threaded Rod Connectors Only

Type	Connector	Symbol
Bare Wire	3/4 in.-16 Rod	-11
2-Hole Spade	3/4 in.-16 Rod	-12
Bare Wire	1 in.-14 Rod	-21
2-Hole Spade	1 in.-14 Rod	-22

NOTES:

- A. Available for 1/0 through 350 conductor sizes only. Use Table X3 for size selection.
- B. Available for 400 through 1000 conductor sizes only. Use Table X3A for size selection.
- C. Available for #2 through 1000 conductor sizes only. Use Table X3 for size selection.
- D. Available for #6 through 4/0 conductor sizes only. Use Table X3 for size selection.

Table W13
USE FOR FOLLOWING PRODUCTS
35MTG
35MTGI

Cable insulation Diameter in (in.)		Symbol for W
Min.	Max.	
0.775	0.885	GA
0.825	0.935	GAB
0.875	0.985	GB
0.930	1.040	GH
0.980	1.115	HA
1.040	1.175	HAB
1.095	1.240	HB
1.160	1.305	HJ
1.220	1.375	JA
1.285	1.395	JAB
1.355	1.520	JB
1.485	1.595	KA
1.530	1.640	KAB
1.575	1.685	KB
1.665	1.785	PA
1.755	1.875	PB

Table X3
USE FOR FOLLOWING PRODUCTS
35MTG

FOR USE WITH STYLE-1,-3, and -4 CONNECTORS ONLY.

SEE NOTES A, C, and D FOR APPLICATION INFORMATION

Conductor SIZE AWG or kcmil	Symbol for X	
	Strand./ Compr.	Compt./ Solid
#6	5	-
#5	4	5
#4	3	4
#3	2	3
#2	1	2
#1	0	1
1/0	10	0
2/0	20	10
3/0	30	20
4/0	40	30
250	250	40
300	300	250
350	350	300
400	400	350
450	450	-
500	500	400
550	550	450
600	600	500
650	650	550
700	750	600
750	750	650
800	800	750
900	900	800
1000	1000	900

Table X3A
USE FOR FOLLOWING PRODUCTS
35MTG













FOR USE WITH STYLE-2 CONNECTORS ONLY.

SEE NOTES B FOR APPLICATION INFORMATION

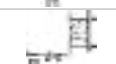
Conductor SIZE AWG or kcmil	Symbol for X	
	Strand./ Compr.	Compt./ Solid
400	400	-
450	450	400
500	500	450
550	550	500
600	600	500
650-700	650	550
750	750	600
800	750	650
1000	1000	-

Cable Terminations

TERMINATIONS

Illustration (not to scale)	Description	Voltage Class	ELASTIMOLD Cat. No.	Notes
	PCT Positioning Bracket	ALL	PB-1	N1, 12
	16THG Bracket	ALL	16TB-2	N6
	Bracket for crossarm 16THG	ALL	16TB-3	N6
	Bracket for riser pole mounting 16THG	ALL	16TB-4	N6
	Bracket for tri-mounting 16THG	ALL	16TB-5	N6
	KELLUMS GRIP Bracket	ALL ALL ALL ALL	35MTB1-A 35MTB1-B 35MTB1-C 35MTB1-D	N1, 2, 6, 7 N1, 3, 6, 7 N1, 4, 6, 7 N1, 5, 6, 7
	KELLUMS Bracket for crossarm mounting	ALL ALL ALL ALL	35MTB3-A 35MTB3-B 35MTB3-C 35MTB3-D	N1, 2, 6, 7 N1, 3, 6, 7 N1, 4, 6, 7 N1, 5, 6, 7
	Bracket (for riser pole mounting)	ALL ALL ALL ALL	35MTB4-A 35MTB4-B 35MTB4-C 35MTB4-D	N1, 2, 6, 7 N1, 3, 6, 7 N1, 4, 6, 7 N1, 5, 6, 7
	KELLUMS Bracket for tri-mounting	ALL ALL ALL ALL	35MTB5-A 35MTB5-B 35MTB5-C 35MTB5-D	N1, 2, 6, 7 N1, 3, 6, 7 N1, 4, 6, 7 N1, 5, 6, 7
	ALUMA FORM Bracket	ALL	1535AFB-1	N1, 6, 7, 13
	ALUMA FORM Bracket for Crossarm mounting	ALL	1535AFB-3	N1, 6, 7, 13
	ALUMA FORM Bracket for riser-pole mounting	ALL	1535AFB-4	N1, 6, 7, 13
	ALUMA FORM Bracket for tri-mounting	ALL	1535AFB-5	N1, 6, 7, 13

- N1. Use with PCT-1 or PCT-2 Terminators.
- N2. Fits overall cable O.D. from 1.195 in. to 1.625 in.
- N3. Fits overall cable O.D. from 0.925 in. to 1.335 in.
- N4. Fits overall cable O.D. from 0.890 in. to 1.185 in.
- N5. Fits overall cable O.D. from 1.500 in. to 2.000 in.
- N6. Use with 16THG and 16THGS Terminators.
- N7. Use with MTG, MTG1 and MSC Terminators.
- N8. For conductors from 1/0 thru 350 kcmil.
- N9. For conductors from 400 kcmil thru 1000 kcmil.
- N10. For conductors from #2 to 1000 kcmil.
- N11. For conductors from #6 thru 4/0.
- N12. Fits overall cable O.D. from 0.750 in. to 1.625 in.
- N13. Fits overall cable O.D. from 0.750 in. to 2.000 in.

Refer to the W and X tables on pages A39 to A41 for sizing to cable insulation diameter and conductor size. For cable shield adapters and jacket seals, see page A30.

Shield Adapters, Sealing and Grounding

Elastimold cable terminations are available in single piece or modular designs. Terminators allow connection and transition from shielded, underground cable to bare overhead conductors and live-front equipment. Units are designed and rated per IEEE Standard 48 for riser pole, padmount, indoor and outdoor applications. PCT1, PCT2, 16THG and 35MTG terminators provide sufficient creep, strike and weather sealing for class 1 outdoor service. PCT1 and PCT2 also include an integral cable jacket seal.

The 35MTGI terminators and 35MSC stress cones are rated for class 2 and class 3 indoor service respectively. Optional mounting brackets, aerial lugs and equipment connectors are available as required.

CABLE ENTRANCE DETAIL

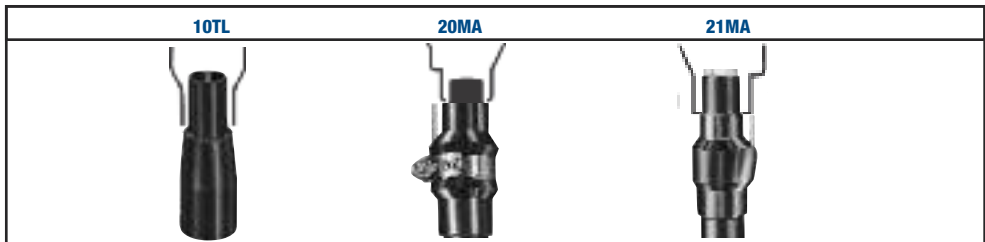
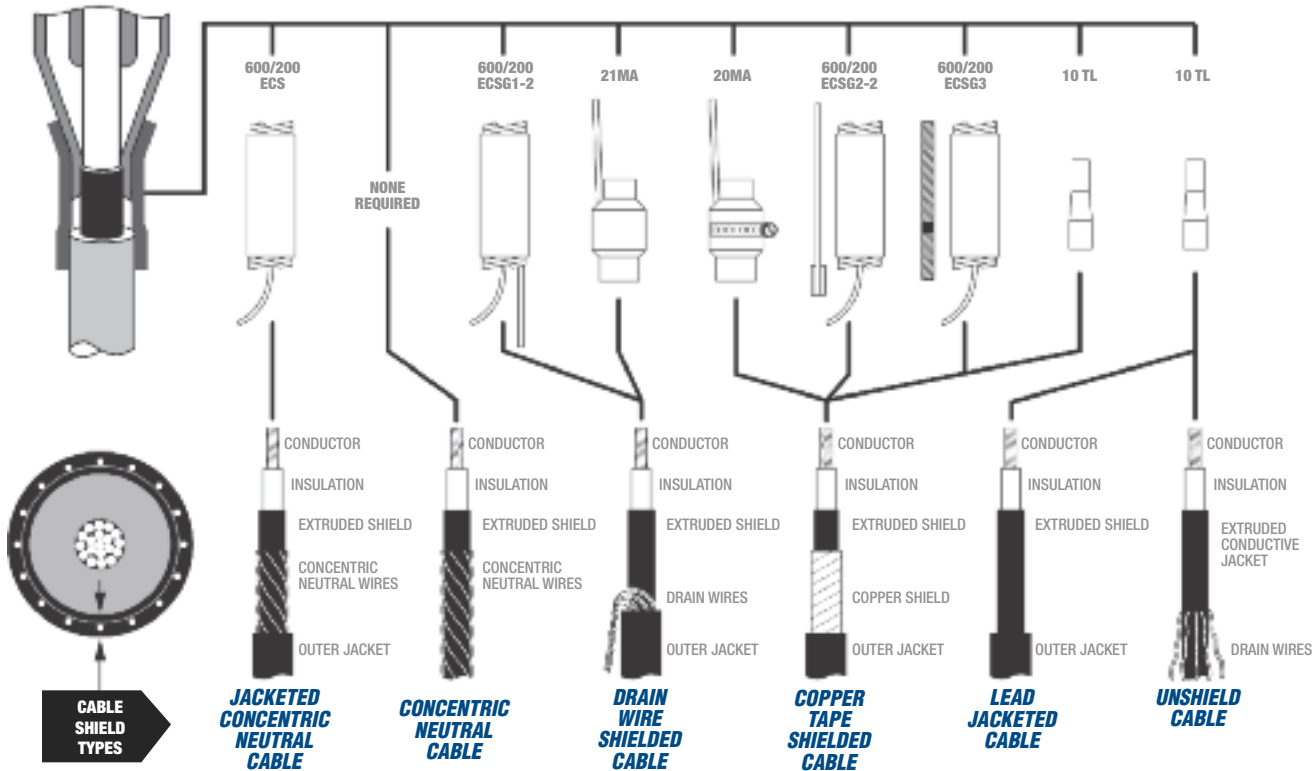
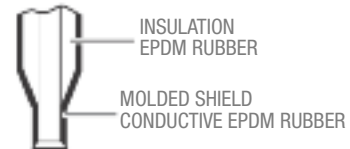

CABLE SHIELD ADAPTERS			
Cable Insulation Dia.	10TL	20MA	21MA
	(in.)	(in.)	(in.)
min.	0.495	0.530	0.530
max.	1.875	1.780	1.780

JACKET SEALS		
Jacket O.D.	200ECS	600ECS
	(in.)	(in.)
min.	0.80	1.28
max.	1.50	2.30

Shield Adapters, Sealing and Grounding

Illustration (not to scale)	Description	ELASTIMOLD Cat. No.	Suffix	Notes
	Cold Shrinkable Jacket Seal	200ECS	-S	N1, 3
	Cold Shrinkable Jacket Seal	600ECS	-S	N1, 4
	Metallic Tape Shield Adapter	20MA-W Use Table W14 for sizing	-OMA	N1, 2, 5, 6
	Wire Shield Adapter	21MA-W Use Table W14 for sizing	-1MA	N1, 2, 5, 6
	Shield Adapter	10TL-W Use Table W15 for sizing	-TL	N1, 2
	Cold Shrinkable Seal w/ Copper Rod and Crimp Connector	200ECSG1-2	-SG1	N1, 3, 5, 6
	Cold Shrinkable Seal w/ Copper Rod and Crimp Connector	600ECSG1-2	-SG1	N1, 4, 5, 6
	Cold Shrinkable Seal w/ Copper Rod and Constant Force Spring	200ECSG2-2	-SG2	N1, 3, 5, 6
	Cold Shrinkable Seal w/ Copper Rod and Constant Force Spring	600ECSG2-2	-SG2	N1, 4, 5, 6
	Cold Shrinkable Seal w/ Copper Braid and Constant Force Spring	200ECSG3	-SG3	N1, 3, 5, 7
	Cold Shrinkable Seal w/ Copper Braid and Constant Force Spring	600ECSG3	-SG3	N1, 4, 5, 7

- N1. To order the kits as separate items, use the Cat. Nos shown in the table.
 Example: To order a cold shrinkable tube as a separate item, use the Cat. No. 200ECS.
 To order the kits as components of other items, add the suffix to the end of the Cat. No.
 Example: To order a cold shrinkable jacket seal as a component of an elbow kit, use the Cat. No. 166LR-A5200-S.
- N2. Only use this suffix with Cat. Nos that designate a "W" housing size. Sizing the main component will also size the suffix adapter.
- N3. Size range 0.80 in. to 1.50 in. jacket diameters. Maximum installed diameter is approx. 02 in.
- N4. Size range 1.28 in. to 2.30 in. jacket diameters. Maximum installed diameter is approx. 2.75 in.
- N5. Voltage rating equal to Elastimold product being used.
- N6. Copper rod size is no. 6 for sizes FA thru HA and no. 2 for sizes HAB thru JB.
- N7. Braid is equivalent to no. 6 copper rod for sizes FA thru HA and no. 2 copper rod for sizes HAB thru JB.

Insulation (in.)		Symbol for W
Min.	Max.	
0.530	0.680	E
0.640	0.820	F
0.760	0.950	G
0.850	1.050	H
0.980	1.180	J
1.090	1.310	K
1.180	1.465	L
1.370	1.630	M
1.515	1.780	N







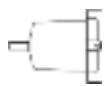

Insulation (in.)		Symbol for W
Min.	Max.	
0.495	0.585	EB
0.525	0.635	EF
0.575	0.585	FA
0.625	0.735	FAB
0.675	0.785	FB
0.725	0.835	FG
0.775	0.885	GA
0.825	0.935	GAB
0.875	0.985	GB
0.930	1.040	GH
0.980	1.115	HA
1.040	1.175	HAB
1.095	1.240	HB
1.160	1.305	HJ
1.220	1.375	JA
1.285	1.395	JAB
1.355	1.520	JB
1.485	1.595	KA
1.530	1.640	KAB
1.575	1.685	KB
1.755	1.875	PB

Equipment Bushings

A complete line of Elastimold® 200 A deepwell and 600 Series apparatus bushings are available for use on transformers, switchgear and other equipment applications.

The bushings incorporate IEEE 386 standard interfaces (shown on page A5) and are constructed of molded epoxy with stainless steel flanges for mounting by welding or gasketed clamp.

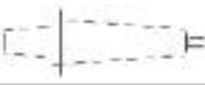
K1601PCC Series bushings are provided with a molded epoxy flange for gasketed clamp mounting only. Bushings are available for use on AIR, OIL or SF6 insulated equipment. Units are rated for submersible, padmount, indoor, outdoor and other applications. Options include hold-down bail tabs and replaceable studs for 200 A deepwell bushings.

Illustration (not to scale)	Description	Voltage Class	ELASTIMOLD Cat. No.	Bushing Shank Length	Notes
	Short Shank Well with bail tabs and non-replaceable well stud	15/25 kV 35 kV	K1601PC-S1 L1601PC-S1	2-3/4 in.	N3, 7, 14
	Short Shank Well with bail tabs and with replaceable well stud	15/25 kV 35 kV	K1601PC-S1-R L1601PC-S1-R	2-3/4 in.	N1, 3, 7, 14
	Short Shank Well without bail tabs and non-replaceable well stud	15/25 kV 35 kV	K1601PC-S2 L1601PC-S2	2-3/4 in.	N3, 7, 14
	Short Shank Well without bail tabs and with replaceable well stud	15/25 kV 35 kV	K1601PC-S2-R L1601PC-S2-R	2-3/4 in.	N1, 3, 7, 14
	Long Shank Well with bail tabs and non-replaceable well stud	15/25 kV 35 kV	K1601PC-T1 L1601PC-T1	9-1/4 in.	N3, 7, 14
	Long Shank Well with bail tabs and with replaceable well stud	15/25 kV 35 kV	K1601PC-T1-R L1601PC-T1-R	9-1/4 in.	N1, 3, 7, 14
	Long Shank Well without bail tabs and non-replaceable well stud	15/25 kV 35 kV	K1601PC-T2 L1601PC-T2	9-1/4 in.	N3, 7, 14
	Long Shank Well without bail tabs and with replaceable well stud	15/25 kV 35 kV	K1601PC-T2-R L1601PC-T2-R	9-1/4 in.	N1, 3, 7, 14
	Epoxy Flange Well with replaceable well stud	15/25 kV	K1601PCC-R		N1,3, 7, 14
	Well w/Insert (K1601PCC-R and 1601A4) Well w/Insert (K1601PCC-R and 2701A4)	15 kV 25 kV	1601CABA4R 2701CABA4R	2-3/4 in.	N1, 3, 8, 14 N1, 3, 9, 14
	200 A Deadbreak Bushing	15/25 kV	K180S4	2-9/16 in.	N3 ,10 ,13
	200 A Deadbreak Bushing	15/25 kV	K180T4	7-11/32 in.	
	200 A Deadbreak Bushing	15/25 kV	K180C4	9-1/4 in.	
	600 A Short Shank Bushing w.o./stud	15/25 kV	K650S1	2-15/16 in.	N2, 5, 11, 14, 15 N2, 5, 12, 14, 16 N3, 5, 11, 14, 15
	600 A Short Shank Bushing w.o./stud	35 kV	750S1		
	600 A Cu Short Shank Bushing w.o./stud	15/25 kV	K675S1		
	600 A Long Shank Bushing w.o./stud	15/25 kV	K650T1	8-9/16 in.	N2, 5, 11, 14, 15 N3, 5, 11, 14, 15 N2, 5, 12, 14, 16 N2, 5, 12, 14, 16
	600 A Cu Long Shank Bushing w.o./stud	15/25 kV	K675T1	8-9/16 in.	
	600 A Long Shank Bushing w.o./stud	35 kV	750T1	8-9/16 in.	
	600 A 12 in. Long Shank Bushing w.o./stud	35 kV	750L12	12 in.	
	600 A In-Air Long Shank Bushing w.o./stud	15/25 kV	K650TBC	8-9/16 in.	N2, 4, 11, 6, 14 N3, 5, 11, 6, 14 N6
	600 A Cu In-Air Long Shank Bush. w./stud	15/25 kV	K675TBC		
	Boot and Collars for K600T1 to use in air	15/25 kV	600BC		

- N1. Replacement stud available separately. Specify 1601RS.
- N2. Equipped with standard aluminum conductor rod.
- N3. Equipped with copper conductor rod.
- N4. Includes 5/8-11 threaded stud at elbow end.
- N5. Includes 5/8-11 threaded hole at elbow end.
- N6. Provides increased creep and strike.
- N7. Includes 1601PPC1 shipping cap.
- N8. Includes 1601APC1 shipping cap.
- N9. Includes 2701-41 shipping cap.

- N10. Includes 180PPC shipping cap.
- N11. Includes 650PPC shipping cap.
- N12. Includes 750PPC1 shipping cap.
- N13. Parking stands for 200 A deadbreak applications are available as separate items. Specify 151PS.
- N14. Parking stands for 200 A loadbreak and 600 A deadbreak applications are available as separate items. Specify 160PS.
- N15. Aluminum stud available separately. Specify 650SA.
- N16. Aluminum stud available separately. Specify 750SA.

How to Specify Size-Sensitive Products

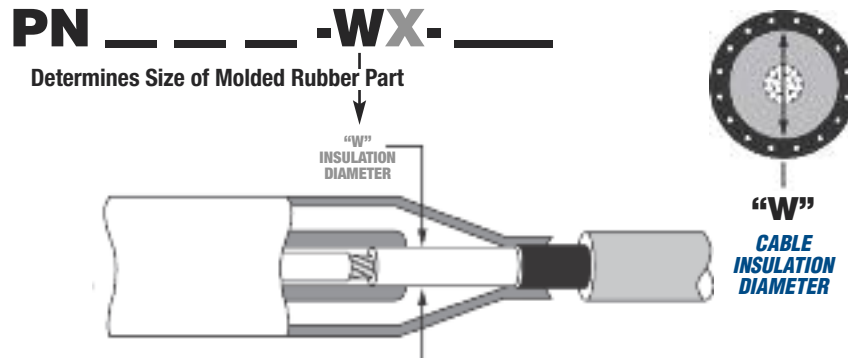

INSULATION DIAMETER SELECTION GUIDE

Elastimold Elbows, cable joints and terminations are designed for application on XLP, EPR and other solid dielectric insulated power cables. These components are constructed of molded elastomer and rely on an interference fit with the cable insulation diameter in order to maintain proper dielectric strength, creep path integrity and a water seal. Elastimold components are available in a wide range of sizes in order to accommodate a variety of cable insulation diameters.

Selection of size-sensitive components requires determining the cable insulation diameter. This can be done in several ways:

- A. Refer to the cable manufacturer's spec sheet for dimensions.
- B. Measure the cable.
- C. If the cable conforms to AEIC or ICEA standards and is:
 1. 15 kV, 175 mil wall thickness, use the table on page A35.
 2. 15 kV, 220 mil wall thickness, use the table on page A36.
 3. 25 kV, 260 mil wall thickness, use the table on page A36.
 4. 35 kV, 345 mil wall thickness, use the table on page A37.

After the cable insulation diameter minimum and maximum has been determined:

1. Locate the W table indicated in the Cat. No. selection chart.
2. Complete the ordering information by selecting and inserting the symbol (given in the W table) into the Cat. No.

Ordering Examples

AEIC

To complete the information required to order a K655LR-W0X elbow for use on standard AEIC 1000 kcmil compressed stranding aluminum 25 kV cable with .260 inch thick insulation wall:

- A. Determine that the insulation diameter (for AEIC cable in the table on pages A35-A37) is 1.645 – 1.770 in.
- B. For this elbow, the Cat. No. selection chart on page A13 indicates to use table W7 for elbow sizing and table X6 for connector sizing.
- C. From table W7 the symbol for W is N.
- D. From table X6 the symbol for X is 410.
- E. The completed Cat. No. therefore is K655LR-N0410.

ICEA

To complete the information required to order a K655LR-W0X elbow for use on standard ICEA 1000 kcmil compressed stranding aluminum 25 kV cable with .260 inch thick insulation wall:

- A. Determine that the insulation diameter (for ICEA cable in the table on pages A35-A37) is 1.645 – 1.740 in.
- B. For this elbow, the Cat. No. selection chart on page A13 indicates to use table W7 for elbow sizing and table X6 for connector sizing.
- C. From table W7 the symbol for W is N.
- D. From table X6 the symbol for X is 410.
- E. The completed Cat. No. therefore is K655LR-N0410.

How to Specify Size-Sensitive Products

PN _ _ _ **-WX-** _ _ _

Determines Crimp Connector Size

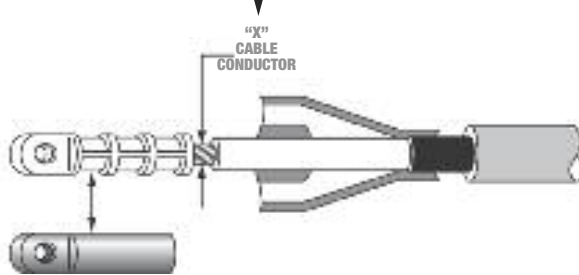

PN _ _ _ **-WX-** _ _ _

"SUFFIX"

CABLE SHIELD AND JACKET

Determines Required Accessories (if any)

- Cable Shield Adaptors
- Cable Grounding Kits
- Cable Jacket Seal

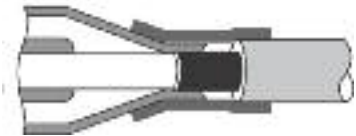

Reference Pages A30 and A31 for application, selection and ordering information.



CONNECTOR SELECTION GUIDE

Elastimold® elbows, cable joints and terminations are furnished with crimp style cable connectors. As standard, these connectors are constructed with a tin-plated aluminum barrel filled with an oxide inhibitor. Most aluminum barrel connectors are universal and are designed for use on either aluminum or copper conductor cable.

When specified, all copper crimp style connectors can be furnished. These connectors are only for use on copper conductor cable and are not for use with aluminum conductor cables. Bi-metallic connectors are constructed with a copper top and an aluminum barrel. Bi-metal connectors can be used on either aluminum or copper conductor cable and are furnished as standard with 200 A Loadbreak Elbows, 200 A Deadbreak Elbows, and PCT, 16 THG or MTG terminators with rod connectors.

Aluminum connectors used in PCJ Cable Joints are rated as follows:

- Aluminum conductor to aluminum conductor, cable rated
- Aluminum conductor to copper conductor, cable rated equal to the aluminum cable

Copper connectors used in PCJ Cable Joints are rated as follows:

- Copper conductor to copper conductor, cable rated

Selection and ordering the proper crimp connector requires determining information relative to the cable conductor as follows:

- Conductor size in AWG or kcmil
- Conductor type (stranded, compressed, compact or solid)
- Conductor material (aluminum or copper)

After the cable conductor information has been determined:

- Locate the X table indicated in the Cat. No. selection chart.
- Complete the ordering information by selecting and inserting the symbol (given in the X table) into the Cat. No.

See the Ordering Example on page A33 for further information.

AEIC and ICEA Cable Insulation Diameter

15 kV 100% – 175 mil Insulation (0.175 in.)
 15 kV 133% – 220 mil Insulation (0.220 in.)
 25 kV 100% – 260 mil Insulation (0.260 in.)
 35 kV 100% – 345 mil Insulation (0.345 in.)

AEIC CS8-06

Specification for Extruded Dielectric,
 Shielded Power Cable Rated 5 - 46 kV

AEIC-Calculated Diameters - Solid and Compressed Stranding from
 Tables C-4 and C-6 and Compact Stranding from Tables C-5 and C-7

ANSI/ICEA S-94-649-2004 and S-97-682-2000

Standard for Concentric Neutral Cables and
 Utility Shielded Power Cables Rated 5 - 46 kV

ICEA-Concentric Stranding Table C-3, Compressed Stranding
 Table C-4, Compact Stranding Table C-5

ICEA Abbreviated, for additional cables please refer to the standard.

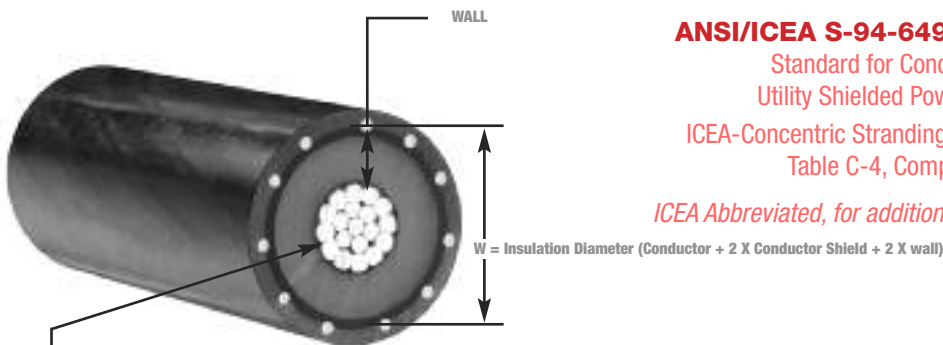

		15 kV Cable (100% level, 175 mil)							
Aluminum and Copper Conductor Size	Industry Standard	Solid Conductor		Stranded Conductor		Compressed Conductor		Compact Conductor	
		Diameter (in.) Over Insulation		Diameter (in.) Over Insulation		Diameter (in.) Over Insulation		Diameter (in.) Over Insulation	
		Min.	Max.	Min.	Max.	Min.	Max.	Min.	Max.
#2	AEIC	0.610	0.700	-	-	0.635	0.725	0.620	0.710
	ICEA	0.610	0.695	0.645	0.730	0.635	0.720	0.620	0.705
#1	AEIC	0.645	0.730	-	-	0.675	0.765	0.655	0.740
	ICEA	0.645	0.725	0.685	0.770	0.675	0.760	0.655	0.735
1/0	AEIC	0.680	0.770	-	-	0.715	0.805	0.690	0.775
	ICEA	0.680	0.760	0.725	0.810	0.715	0.800	0.690	0.775
2/0	AEIC	-	-	-	-	0.760	0.850	0.730	0.815
	ICEA	-	-	0.775	0.855	0.760	0.845	0.730	0.815
3/0	AEIC	-	-	-	-	0.810	0.900	0.775	0.865
	ICEA	-	-	0.825	0.905	0.810	0.895	0.775	0.860
4/0	AEIC	-	-	-	-	0.865	0.955	0.830	0.915
	ICEA	-	-	0.880	0.965	0.865	0.950	0.830	0.910
250	AEIC	-	-	-	-	-	-	-	-
	ICEA	-	-	0.935	1.020	0.920	1.005	0.880	0.965
350	AEIC	-	-	-	-	1.025	1.115	0.980	1.065
	ICEA	-	-	1.045	1.130	1.025	1.110	0.980	1.065
500	AEIC	-	-	-	-	1.150	1.245	1.100	1.185
	ICEA	-	-	1.175	1.260	1.150	1.235	1.100	1.185
750	AEIC	-	-	-	-	1.340	1.440	1.280	1.370
	ICEA	-	-	1.370	1.455	1.340	1.425	1.280	1.365
1000	AEIC	-	-	-	-	1.485	1.590	1.430	1.520
	ICEA	-	-	1.520	1.610	1.485	1.575	1.430	1.515

ICEA NOTE: Diameters specified in the above table are different than specified by AEIC CS8-00.
 Consult your Regional Sales Office for proper selection of accessories. Diameters to be measured in accordance with 9.6.

AEIC and ICEA Cable Insulation Diameter

		15 kV Cable (133% level, 220 mil)							
Aluminum and Copper Conductor Size	Industry Standard	Solid Conductor		Stranded Conductor		Compressed Conductor		Compact Conductor	
		Diameter (in.) Over Insulation		Diameter (in.) Over Insulation		Diameter (in.) Over Insulation		Diameter (in.) Over Insulation	
		Min.	Max.	Min.	Max.	Min.	Max.	Min.	Max.
#2	AEIC	0.700	0.790	–	–	0.725	0.815	0.710	0.800
	ICEA	0.700	0.790	0.735	0.825	0.725	0.815	0.710	0.800
#1	AEIC	0.735	0.820	–	–	0.765	0.855	0.745	0.830
	ICEA	0.735	0.820	0.775	0.865	0.765	0.855	0.745	0.830
1/0	AEIC	0.770	0.860	–	–	0.805	0.895	0.780	0.865
	ICEA	0.770	0.855	0.815	0.905	0.805	0.895	0.780	0.865
2/0	AEIC	–	–	–	–	0.850	0.940	0.820	0.905
	ICEA	–	–	0.865	0.950	0.850	0.935	0.820	0.905
3/0	AEIC	–	–	–	–	0.900	0.990	0.865	0.955
	ICEA	–	–	0.915	1.000	0.900	0.985	0.865	0.955
4/0	AEIC	–	–	–	–	0.955	1.045	0.920	1.005
	ICEA	–	–	0.970	1.060	0.955	1.045	0.920	1.005
250	AEIC	–	–	–	–	–	–	–	–
	ICEA	–	–	1.025	1.115	1.010	1.100	0.970	1.060
350	AEIC	–	–	–	–	1.115	1.205	1.070	1.155
	ICEA	–	–	1.135	1.220	1.115	1.200	1.070	1.155
500	AEIC	–	–	–	–	1.240	1.335	1.190	1.275
	ICEA	–	–	1.265	1.355	1.240	1.330	1.190	1.275
750	AEIC	–	–	–	–	1.430	1.530	1.370	1.460
	ICEA	–	–	1.460	1.550	1.430	1.520	1.370	1.460
1000	AEIC	–	–	–	–	1.575	1.680	1.520	1.610
	ICEA	–	–	1.610	1.705	1.575	1.670	1.520	1.610

		25 kV Cable (100% level, 260 mil)							
Aluminum and Copper Conductor Size	Industry Standard	Solid Conductor		Stranded Conductor		Compressed Conductor		Compact Conductor	
		Diameter (in.) Over Insulation		Diameter (in.) Over Insulation		Diameter (in.) Over Insulation		Diameter (in.) Over Insulation	
		Min.	Max.	Min.	Max.	Min.	Max.	Min.	Max.
#1	AEIC	0.805	0.900	–	–	0.835	0.935	0.815	0.910
	ICEA	0.805	0.895	0.845	0.935	0.835	0.925	0.815	0.905
1/0	AEIC	0.840	0.940	–	–	0.875	0.975	0.850	0.945
	ICEA	0.840	0.930	0.885	0.980	0.875	0.965	0.850	0.940
2/0	AEIC	–	–	–	–	0.920	1.020	0.890	0.985
	ICEA	–	–	0.935	1.025	0.920	1.010	0.890	0.980
3/0	AEIC	–	–	–	–	0.970	1.070	0.935	1.035
	ICEA	–	–	0.985	1.075	0.970	1.060	0.935	1.030
4/0	AEIC	–	–	–	–	1.025	1.125	0.990	1.085
	ICEA	–	–	1.040	1.135	1.025	1.115	0.990	1.080
250	AEIC	–	–	–	–	–	–	–	–
	ICEA	–	–	1.095	1.190	1.080	1.175	1.040	1.135
350	AEIC	–	–	–	–	1.185	1.295	1.140	1.245
	ICEA	–	–	1.205	1.295	1.185	1.275	1.140	1.230
500	AEIC	–	–	–	–	1.310	1.425	1.260	1.365
	ICEA	–	–	1.335	1.430	1.310	1.405	1.260	1.350
750	AEIC	–	–	–	–	1.500	1.620	1.440	1.550
	ICEA	–	–	1.530	1.625	1.500	1.595	1.440	1.535
1000	AEIC	–	–	–	–	1.645	1.770	1.590	1.700
	ICEA	–	–	1.680	1.775	1.645	1.740	1.590	1.685

ICEA NOTE: Diameters specified in the above table are different than specified by AEIC CS8-00. Consult your Regional Sales Office for proper selection of accessories. Diameters to be measured in accordance with 9.6.

AEIC and ICEA Cable Insulation Diameter

		35 kV Cable (100% level, 345 mil)							
Aluminum and Copper Conductor Size	Industry Standard	Solid Conductor		Stranded Conductor		Compressed Conductor		Compact Conductor	
		Diameter (in.) Over Insulation		Diameter (in.) Over Insulation		Diameter (in.) Over Insulation		Diameter (in.) Over Insulation	
		Min.	Max.	Min.	Max.	Min.	Max.	Min.	Max.
1/0	AEIC	1.010	1.110	–	–	1.045	1.145	1.020	1.115
	ICEA	1.010	1.110	1.055	1.155	1.045	1.145	1.020	1.120
2/0	AEIC	–	–	–	–	1.090	1.190	1.060	1.155
	ICEA	–	–	1.105	1.200	1.090	1.190	1.060	1.160
3/0	AEIC	–	–	–	–	1.140	1.240	1.105	1.205
	ICEA	–	–	1.155	1.255	1.140	1.240	1.105	1.205
4/0	AEIC	–	–	–	–	1.195	1.295	1.160	1.255
	ICEA	–	–	1.210	1.310	1.195	1.295	1.160	1.260
250	AEIC	–	–	–	–	–	–	–	–
	ICEA	–	–	1.265	1.370	1.250	1.350	1.210	1.315
350	AEIC	–	–	–	–	1.355	1.470	1.310	1.420
	ICEA	–	–	1.375	1.475	1.355	1.455	1.310	1.410
500	AEIC	–	–	–	–	1.480	1.600	1.430	1.540
	ICEA	–	–	1.505	1.605	1.480	1.580	1.430	1.530
750	AEIC	–	–	–	–	1.670	1.795	1.610	1.725
	ICEA	–	–	1.700	1.800	1.670	1.770	1.610	1.710
1000	AEIC	–	–	–	–	1.815	1.945	1.760	1.875
	ICEA	–	–	1.850	1.955	1.815	1.920	1.760	1.865

ICEA NOTE: Diameters specified in the above table are different than specified by AEIC CS8-00. Consult your Regional Sales Office for proper selection of accessories. Diameters to be measured in accordance with 9.6.

AEIC and ICEA Cable Insulation Diameter



Conductor Diameters for Copper and Aluminum (Class B)
Stranded, Compressed, Compact and Solid Cables

Conductor Size AWG or kcmil	No. of Strands and their Nom. Strand Dia. (in.)	Cross-sectional Area		Stranded Conductors (in.)	Compressed Conductors (in.)	Compact Conductors (in.)	Solid Conductors (in.)
		Square (in.)	mm ² Conversion				
14 12 10 8 6 4 2	7 x 0.0242	0.0032	2.08	0.073	—	—	0.064
	7 x 0.0305	0.0051	3.31	0.092	—	—	0.081
	7 x 0.0385	0.0082	5.26	0.116	—	—	0.102
	7 x 0.0486	0.0130	8.37	0.146	—	—	0.129
	7 x 0.0612	0.0206	13.30	0.184	—	—	0.162
	7 x 0.0772	0.0328	21.15	0.232	—	—	0.204
	7 x 0.0974	0.0521	33.62	0.292	0.283	0.268	0.258
1 1/0 2/0 3/0 4/0	19 x 0.0664	0.0657	42.41	0.332	0.322	0.299	0.289
	19 x 0.0745	0.0829	53.49	0.373	0.362	0.336	0.325
	19 x 0.0837	0.1054	67.43	0.418	0.405	0.376	—
	19 x 0.0940	0.1318	85.01	0.470	0.456	0.423	—
	19 x 0.1055	0.1662	107.2	0.528	0.512	0.475	—
250 350 500	37 x 0.0822	0.1964	127	0.575	0.558	0.520	—
	37 x 0.0973	0.2749	177	0.681	0.661	0.616	—
	37 x 0.1162	0.3924	253	0.813	0.789	0.736	—
600 700 750 800 900 1000	61 x 0.0992	0.4712	304	0.893	0.866	0.813	—
	61 x 0.1071	0.5498	355	0.964	0.935	0.877	—
	61 x 0.1109	0.5890	380	0.998	0.968	0.908	—
	61 x 0.1145	0.6283	405	1.031	1.000	0.938	—
	61 x 0.1215	0.7069	456	1.094	1.061	0.999	—
	61 x 0.1280	0.7854	507	1.152	1.117	1.060	—
1100 1200 1250 1300 1400 1500	91 x 0.1099	0.8639	557	1.209	1.173	—	—
	91 x 0.1148	0.9425	608	1.263	1.225	—	—
	91 x 0.1172	0.9818	633	1.289	1.250	—	—
	91 x 0.1195	1.021	659	1.315	1.276	—	—
	91 x 0.1240	1.100	709	1.364	1.323	—	—
	91 x 0.1284	1.178	760	1.412	1.370	—	—
1600 1700 1750 1800 1900 2000	127 x 0.1122	1.257	811	1.459	1.415	—	—
	127 x 0.1157	1.335	861	1.504	1.459	—	—
	127 x 0.1174	1.374	887	1.526	1.480	—	—
	127 x 0.1191	1.414	912	1.548	1.502	—	—
	127 x 0.1223	1.492	963	1.590	1.542	—	—
	127 x 0.1225	1.571	1010	1.632	1.583	—	—

WX Size Tables

Table W1 USE FOR FOLLOWING PRODUCTS 151SP/SR 151LS/LY 165/166LR 165/166LRJS	Cable Insulation Diameter (in.)		Symbol for W
	Min.	Max.	
	0.575	0.740	A
	0.635	0.905	B
	0.805	1.060	C
	0.890	1.220	D

Table W2 USE FOR FOLLOWING PRODUCTS 273RLR 274RLR	Cable Insulation Diameter (in.)		Symbol for W
	Min.	Max.	
	0.760	0.950	G
	0.850	1.050	H
	0.980	1.180	J
	1.090	1.310	K

Table W3 USE FOR FOLLOWING PRODUCTS 375LR 376LR	Cable Insulation Diameter (in.)		Symbol for W
	Min.	Max.	
	0.850	1.050	H
	0.980	1.180	J
	1.090	1.310	K
	1.235	1.465	L

Table W4 USE FOR FOLLOWING PRODUCTS 156LR 167/168RLR 167LRT	Cable Insulation Diameter (in.)		Symbol for W
	Min.	Max.	
	0.640	0.820	F
	0.760	0.950	G
	0.850	1.050	H
	0.980	1.180	J
	1.090	1.310	K

Table W5 USE FOR FOLLOWING PRODUCTS 167/168ELR 273/274ELR	Cable Insulation Diameter (in.)		Symbol for W
	Min.	Max.	
	0.665	0.895	6689
	0.740	0.950	7495
	0.880	1.100	88110
	1.090	1.310	K

Table W6 USE FOR FOLLOWING PRODUCTS 10EP 152EA 160CA* (*EB-FA Only)	Cable Insulation Diameter (in.)		Symbol for W
	Min.	Max.	
	0.495	0.585	EB
	0.525	0.635	EF
	0.575	0.685	FA
	0.625	0.735	FAB
	0.675	0.785	FB
	0.725	0.835	FG
	0.775	0.885	GA
	0.825	0.935	GAB
	0.875	0.985	GB

Table W7 USE FOR FOLLOWING PRODUCTS K656I/CY/CH K655/656LR K655/656SR 655/656LINK K655/656LINK 655/656ETP K655/656ETP 655/656RTP K655/656L RTP 655/656BI-LINK K655/656BI-LINK 655CA/CK/TCK	Cable Insulation Diameter (in.)		Symbol for W
	Min.	Max.	
	0.640	0.820	F
	0.760	0.950	G
	0.850	1.050	H
	0.980	1.180	J
	1.090	1.310	K
	1.180	1.465	L
	1.280	1.430	LM
	1.370	1.630	M
	1.515	1.780	N
	1.725	1.935	P

Table W8 USE FOR FOLLOWING PRODUCTS 15PCJ-1 15PCJ-2	Cable Insulation Diameter (in.)		Symbol for W
	Min.	Max.	
	0.640	0.820	F
	0.760	0.950	G
	0.850	1.050	H
	0.980	1.180	J
	1.090	1.310	K
	1.180	1.465	L
	1.280	1.430	LM
	1.370	1.630	M
	1.515	1.780	N
	1.725	1.935	P
	1.900	2.120	Q

Table W9 USE FOR FOLLOWING PRODUCTS 25PCJ-1 25PCJ-2 755/756LR 755/756LINK 755/756ETP 755/756L RTP 755/756BI-LINK 755CA/CK/TCK	Cable Insulation Diameter (in.)		Symbol for W
	Min.	Max.	
	0.760	.950	G
	0.850	1.050	H
	0.980	1.180	J
	1.090	1.310	K
	1.180	1.465	L
	1.280	1.430	LM
	1.370	1.630	M
	1.515	1.780	N
	1.725	1.935	P
	1.900	2.120	Q

Please see page A28 for Table W13 and page A31 for Tables W14 and W15.

WX Size Tables

Table W10 USE FOR FOLLOWING PRODUCTS 35PCJ-1 35PCJ-2	Cable Insulation Diameter (in.)		Symbol for W
	Min.	Max.	
	0.850	1.050	
0.980	1.180	J	
1.090	1.310	K	
1.180	1.465	L	
1.280	1.430	LM	
1.370	1.630	M	
1.515	1.780	N	
1.725	1.935	P	
1.900	2.120	Q	

Table W11 USE FOR FOLLOWING PRODUCTS 35MSC 35MSCI	Cable Insulation Diameter (in.)		Symbol for W
	Min.	Max.	
	0.495	0.585	
0.525	0.635	EF	
0.575	0.685	FA	
0.625	0.735	FAB	
0.675	0.785	FB	
0.725	0.835	FG	
0.775	0.885	GA	
0.825	0.935	GAB	
0.875	0.985	GB	
0.930	1.040	GH	
0.980	1.115	HA	
1.040	1.175	HAB	
1.095	1.240	HB	
1.160	1.305	HJ	
1.220	1.375	JA	
1.285	1.395	JAB	
1.355	1.520	JB	
1.485	1.595	KA	
1.530	1.640	KAB	
1.575	1.685	KB	
1.665	1.785	PA	
1.755	1.875	PB	

Table W12 USE FOR FOLLOWING PRODUCTS 16THG 16THGS 16THGH	Cable Insulation Diameter (in.)		Symbol for W
	Min.	Max.	
	0.495	0.585	
0.525	0.635	EF	
0.575	0.685	FA	
0.625	0.735	FAB	
0.675	0.785	FB	
0.725	0.835	FG	
0.775	0.885	GA	
0.825	0.935	GAB	
0.875	0.985	GB	
0.930	1.040	GH	
0.980	1.115	HA	

Table W16 USE FOR FOLLOWING PRODUCTS 275/276LR 275/276LRS	Cable Insulation Diameter (in.)		Symbol for W	
	Min.	Max.		
	0.635	0.905		B
	0.800	1.060		CC
	0.940	1.170		DD
1.090	1.310	E		

Table X1 USE FOR FOLLOWING PRODUCTS 167/168ELR 273/274ELR 156LR 165/166LR 275/276LR 167LRT 167/168RLR 273/274RLR 00400 02500 02509 02702 02800 K151SP/SR K151LS/LY	Conductor Size AWG or kcmil	Symbol for X	
		Strand./ Compr.	Compt./ Solid.
		#4	200
#3	210	200	
#2	220	210	
#1	230	220	
1/0	240	230	
2/0	250	240	
3/0	260	250	
4/0	270	260	
250	-	270	

Table X2 USE FOR FOLLOWING PRODUCTS 375/376LR	Conductor Size AWG or kcmil	Symbol for X	
		Strand./ Compr.	Compt./ Solid.
		1/0	240
2/0	250	240	
3/0	260	250	
4/0	270	260	

Table X3 USE FOR FOLLOWING PRODUCTS 35MTG NOTE: SEE PAGE A24 FOR DETAILED APPLICATION INFORMATION	Conductor Size AWG or kcmil	Symbol for X	
		Strand./ Compr.	Compt./ Solid.
		#6	5
#5	4	5	
#4	3	4	
#3	2	3	
#2	1	2	
#1	0	1	
1/0	10	0	
2/0	20	10	
3/0	30	20	
4/0	40	30	
250	250	40	
300	300	250	
350	350	300	
400	400	350	
450	450	-	
500	500	400	
550	550	450	
600	600	500	
650	650	550	
700	750	600	
750	750	650	
800	800	750	
900	900	800	
1000	1000	900	

WX Size Tables

Table X3A USE FOR FOLLOWING PRODUCTS 35MTG NOTE: SEE PAGE A24 FOR DETAILED APPLICATION INFORMATION	Conductor Size AWG or kcmil	Symbol for X	
		Strand./ Compr.	Compt./ Solid.
	400	400	–
	450	450	400
	500	500	450
	550	550	500
	600	600	500
	650-700	650	550
	750	750	600
	800	750	650
	1000	1000	–

Table X4 USE FOR FOLLOWING PRODUCTS 16THGS 16CAS	Riser Conductor Size AWG Solid	Symbol for X
	#2	2
	#1	2
	1/0	10
	2/0	20
	3/0	30
	4/0	30

Table X6 USE FOR FOLLOWING PRODUCTS 655/656LRTP K655/656LRTP 755/756LRTP K656I/Y/H K655/656LR 755/756LR K655/656SR 655/656LINK K655/656LINK 755/756LINK 655/656ETP K655/656ETP 755/756ETP 655/656BI-LINK K655/656BI-LINK 755BI-LINK 655CK 755CK 655TCK 03600 03602 03700 03702	Conductor Size AWG or kcmil	Symbol for X	
		Strand./ Compr.	Compt./ Solid.
	#2	220	210
	#1	230	220
	1/0	240	230
	2/0	250	240
	3/0	260	250
	4/0	270	260
	250	280	270
	300	290	280
	350	300	290
	400	310	300
	450	320	310
	500	330	320
	550	340	320
	600	350	330
	650	360	340
	700	380	350
	750	380	360
	800	390	360
	900	400	380
	1000	410	400
	1250	440	420

Table X7 USE FOR FOLLOWING PRODUCTS 15PCJ1 25PCJ1 35PCJ1 15PCJ2 25PCJ2 35PCJ2	Conductor Size AWG or kcmil	Symbol for X	
		Strand./ Compr.	Compt./ Solid.
	#6	180	–
	#5	190	180
	#4	200	190
	#3	210	200
	#2	220	210
	#1	230	220
	1/0	240	230
	2/0	250	240
	3/0	260	250
	4/0	270	260
	250	280	270
	300	290	280
	350	300	290
	400	310	300
	450	320	310
	500	330	310
	550	340	320
	600	350	330
	650	360	340
	700	380	350
	750	380	360
	800	390	380
	900	400	380
	1000	410	400
	1250	440	420

Table X8 USE FOR FOLLOWING PRODUCTS 16THG 16TCA	Conductor Size AWG or kcmil	Symbol for X	
		Strand./ Compr.	Compt./ Solid.
	#6	180	–
	#5	190	180
	#4	200	190
	#3	210	200
	#2	220	210
	#1	230	220
	1/0	240	230
	2/0	250	240
	3/0	260	250
	4/0	270	260

Table X9 USE FOR FOLLOWING PRODUCTS PCT1 PCT2 01000 01010	Conductor Size AWG or kcmil	Symbol for X	
		Strand./ Compr.	Compt./ Solid.
	#2	220	210
	#1	230	220
	1/0	240	230
	2/0	250	240
	3/0	260	250
	4/0	270	260

Shrink-Fit Cable Joints

The Faster, Easier Way to Splice Medium-Voltage Cables in Direct-Burial, Underground or Overhead Applications.

Features

- Automatic core removal without ripcords or heat required for installation
- High-quality molded EPDM elastomer housing withstands the elements in harsh direct-burial, vault, manhole and overhead applications
- Four sizes support a wide range of cable and conductor sizes
- IEEE 404 rated shrink-fit cable joint

For over 50 years, the Elastimold® brand has been associated with reliable, high-quality, pre-molded power cable splices that are designed to stand the rigors of the toughest utility applications. These products provide a cost-effective method to splice medium voltage cables using a “push-on” motion, and allowing cable neutrals to be solidly connected across the body of the splice without the use of any external braids. For those who prefer a more range-taking solution without the use of any physical force to install, the only options available have been cumbersome heat-shrink products that require multiple steps and the use of an open flame that may not result in uniform cable coverage, or over-designed cold-shrink products that either use awkward, entangling ripcords or expensive braid/jacket combinations that do not offer the ability to solidly connect neutrals across the splice.

Now there's a faster and easier way to splice medium-voltage cables — one that combines all of the convenience and flexibility of a pre-molded splice, with the range-taking ease of installation offered in a cold- or heat-shrink product, but without the use of ripcords, heat or excessive force. Introducing, the NEW Elastimold® Shrink-Fit Cable Joints from Thomas & Betts!

The Shrink-Fit Cable Joints are made of the same molded EPDM elastomer as our other Elastimold® cable accessories. This high-performance material offers more durability than silicone for direct burial. The joints feature a four-piece plastic support core, which is placed over the cable for installation of the splice. The support core is then easily removed with the supplied tool, allowing the elastomer joint to contour over the spliced cable for a uniform seal every time.

Each Elastimold® Shrink-Fit Cable Joint covers a wide range of cable sizes, features an insulated, semi-conductive shield and can be used with either a standard aluminum or optional copper compression splice. Optional kits are available for neutral, shielding and jacket restoration.



SFJ115
Shrink-Fit Cable Joint



SFJ415
Shrink-Fit Cable Joint



Disposable four-piece plastic support core

Typical Applications

- Direct Burial
- Handhole/Pullbox
- Manhole
- Vault
- Overhead



Shrink-Fit Cable Joints

Installation Sequence

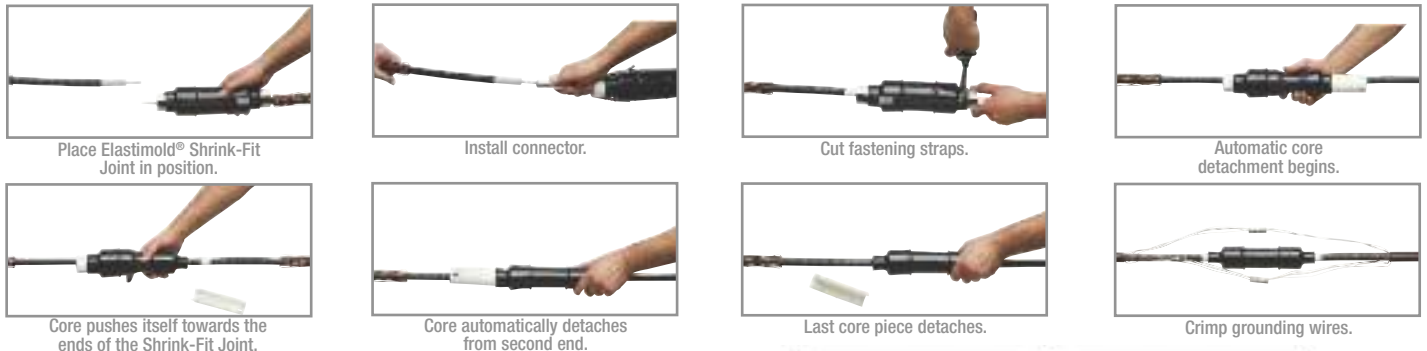

Ratings

Volt Class	15 kV	25/28 kV	35 kV
Max. Phase-to-Ground Operating Voltage	8.7 kV	14.4 kV	20.2 kV
BIL Impulse Withstand (1.2 x 50µsec. wave)	110 kV	150 kV	200 kV
Corona Extinction Level @ 3.0 pC Sensitivity	13 kV	22 kV	30 kV
DC Withstand during Installation	56 kV	80 kV	100 kV
DC Withstand up to 5 yrs.* — XLPE Insulation	18 kV	25 kV	31 kV
DC Withstand up to 5 yrs.* — EPR Insulation	45 kV	64 kV	80 kV
AC Withstand at 60 Hz for 60 sec.	35 kV	52 kV	69 kV
Continuous Current	Equal to that of cable		
Short-Term Current	Equal to that of cable up to 35 kV		

*Reference: AEC CS6 and CS8, section L.2.

Dimensions

Cable Joint Size	D (in.)	L (in.)
1	1.85	11
2	2.12	16
3	2.4	18
4	2.6	18

Insulation Range

Cable Joint Size	Min. (in.)	Max. (in.)	Min. (mm)	Max. (mm)
1	0.620	0.780	15.75	19.81
2	0.815	0.920	20.70	23.37
3	0.935	1.190	23.75	30.23
4	1.210	1.760	30.73	44.70

How to construct a catalogue number for an Elastimold® Shrink-Fit Cable Joint:

S F J

Cable Joint Size			
Size Code	Wall Thickness (mils)	Min. Conductor Size*	Max. Conductor Size*
15 kV			
1	175	#2 AWG	3/0 AWG
2		4/0 AWG	250 kcmil
3		350 kcmil	600 kcmil
4		700 kcmil	1000 kcmil
1	220	#2 AWG	1/0 AWG
2		2/0 AWG	4/0 AWG
3		250 kcmil	500 kcmil
4	600 kcmil	1000 kcmil	
25/28 kV			
2	260	#1 AWG	2/0 AWG
3		3/0 AWG	350 kcmil
4		500 kcmil	1000 kcmil
35 kV			
3	345	1/0 AWG	4/0 AWG
4		250 kcmil	1000 kcmil

Voltage Rating	
15	11 kV
25	25/28 kV
35	35 kV

Connector Type	
C	Crimp

Conductor	
1	Aluminum
2	Copper

X Code	Conductor Size (AWG or Kcmil)	
	Stranded/Compressed	Solid/Compact
210	-	#2 AWG
220	#2 AWG	#1 AWG
230	#1 AWG	1/0 AWG
240	1/0 AWG	2/0 AWG
250	2/0 AWG	3/0 AWG
260	3/0 AWG	4/0 AWG
270	4/0 AWG	250 kcmil
280	250 kcmil	300 kcmil
290	300 kcmil	350 kcmil
300	350 kcmil	400 kcmil
310	400 kcmil	500 kcmil
330	500 kcmil	650 kcmil
360	650 kcmil	750 kcmil
380	750 kcmil	900 kcmil
400	900 kcmil	1000 kcmil
410	1000 kcmil	-

* Based on the minimum compact AEIC and ICEA cable insulation diameters. Note: Each kit contains shrink-fit housing on removable core, splice connector, lubricant, installation instructions and crimp chart. For ordering information on optional neutral, shielding and jacket restoration kits, please contact your Regional Sales Office.

Ranger2™ Terminations

Overview

Elastimold® Ranger2™ Terminations are specifically designed for use on 15 thru 35 kV, XLP or EPR insulated, underground power distribution cable systems. Units allow proper transition and connection of the underground cable system to bare overhead conductors and live front equipment. Applications include indoor, outdoor, riser pole, padmounted and other live front or weather exposed installations. Designs use advanced silicone rubber insulating materials to provide necessary creep, strike, weather sealing and contamination resistance, assuring proper performance in the most severe conditions. The grey color blends in with outdoor environments.

Ranger2 Terminations support a wide application range with only three sizes required to cover #2 AWG through 1250 kcmil cables. The single-piece 15 kV and 25 kV shrink-fit design makes installation effortless, and the two-piece 35 kV design facilitates easier core removal. Simply position the terminator on the prepared cable and remove the center core. Units are compact and lightweight, allowing installation in restricted spaces and free-hanging applications.



Silicone Polymer Housings

The R2T and R2IT terminations are manufactured using an optimized weather-resistant silicone formulation. The housing offers superior cable sealing and voltage withstand characteristics. Elastimold terminations meet or exceed all requirements of IEEE Standard 48 for Class 1 outdoor or Class 2 indoor terminations. Unit tests include voltage withstand wet and dry, before and after load cycling on units installed on maximum conductor sized cable.

Stress Relief

The R2T and R2IT terminations provide electric stress control for the cable by means of a flexible tube with a high permittivity dielectric constant. The stress-relief tube is preassembled on the core under the polymer housing. As the core is removed, the stress-relief tube and housing shrink onto the cable at the same time, in exactly the right position. No secondary operations are required during installation. The electrical fields are refracted through the high dielectric constant tube and housing as shown.

Installation

Standard cable preparation techniques are used for all R2T, Elastimold Ranger2 Outdoor Terminations, and R2IT, Elastimold Ranger2 Indoor Terminations. The Elastimold shrink-fit terminations are assembled on a removable core. After the termination is placed onto the prepared cable, the core is removed by pulling on the end. The housing then collapses onto the prepared cable. Memory of the material provides the interface solid dielectric and sealing properties required to meet the electrical ratings and prevent the ingress of moisture.

Kit Contents

Every R2T and R2IT comes complete with housing and stress tube preassembled on the core, ready for installation. Easy-to-read installation instructions will take you from cable preparation through installation. All kits include a tube of silicone grease, two plastic gloves and one strip of self-fusing silicone tape. Outdoor kits also include mastic for sealing. Metallic Tape (M) kits include a grounding adapter for Tape Shield, Wire Shield and UniShield cables. LC Shield (L) kits include a high ampacity grounding adapter for Longitudinally Corrugated Shield, Tape Shield and Wire over Tape Shield cables.

Stress Relief Voltage Stress

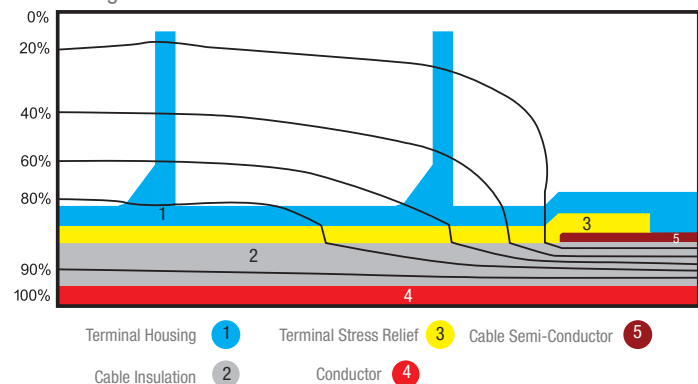

Ranger2™ Terminations

Overview

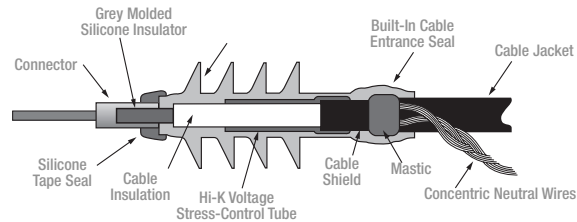

Typical Installation on Jacketed Concentric Neutral (JCN) Cable

Features	Benefits/Descriptions
Silicone Polymer Housing	Superior memory and weathering characteristics
Shrink-Fit Housing	Uses common installation procedures and cable preparation dimensions. Field-removable center core allows for easy installation.
Three Different Shed Designs for Superior Weathering	<ul style="list-style-type: none"> • Four sheds for 15 kV outdoor model • Six sheds for 25/28 kV outdoor model • Eight sheds for 35 kV outdoor model
Wide Range	Three sizes cover entire cable range from #2 AWG to 1250 kcmil. Units accommodate popular XLP and EPR cable types and shield constructions.
Integral Hi-K Voltage Stress-Control Tube	Provides uniform voltage grading over the length of the termination. Eliminates damaging voltage stress concentrations at the cable insulation shield edge. Thick wall construction securely maintains critical interface pressure for consistent long term reliability and performance.
Pull-Down Tabs for Easy Installation of Built-In Jacket Seal	Accommodates CN, JCN, Tape, Wire or LC shielded cable construction
Lightweight, Compact Design	Installs in restricted spaces. Permits application where free hanging is desired.
Dark Grey Molded Silicone Insulator	Blends well into outdoor environments. Utilizes specially formulated silicone materials with improved UV stability, track, erosion and weather resistance. Outdoor styles feature large diameter, multi-shed profile with extra creep and strike for enhanced performance under the worst environmental conditions.
Optional Connectors	Connector with copper stem, one-hole and two-hole spade connector
Optional Cable and Support Bracket	Three sizes, ranging from 0.80 in. – 1.95 in. O.D.

Certified

Elastimold Ranger2 Terminations have been designed and tested per applicable portions of ANSI, IEEE, AEIC, ICEA and other industry standards.

IEEE 48	Standard for indoor and outdoor cable terminations
ANSI C119.4	Standard for cable connectors for aluminum and copper conductors
AEIC CS8-06 and ANSI/ICEA S-94-649-2004 and S-97-682-2000	Standards for XLP and EPR insulated cables

Application Information

IEEE 48 Classification	Outdoor = Class 1A, Indoor = Class 2
Ambient Temperature Range	-30°C to 65°C
Power System Frequency	48 to 62 Hz
Altitude Range	3 300 ft. max.
Mounting	Free hanging or optional bracket

Ratings

Ratings	Indoor	Outdoor	Outdoor	Outdoor
Termination Catalogue Series	R2IT15	R2T15	R2T28	R2T35
Sizes Available*	1, 2, 4	1, 2, 4	2, 4	2, 4
Voltage Rating (kV)	15	15	25/28	35
Max. Design Voltage to Ground (kV)	9.5	9.5	16	22
Corona Extinction Voltage (kV) (≤3 p.c.) (Partial Discharge)	13	13	22	30
Insulation Withstand Voltage:				
Lightning Impulse (BIL Dry 110 Withstand) (kV Crest)	110	110	150	200
10 Sec. Wet (60 Hz) (kV)	—	45	60	80
1 Minute Dry (60 Hz) (kV)	50	50	65	90
5 Hour Dry (60 Hz) (kV)	36	35	55	75
DC Withstand 15 Min. Dry (kV)	75	75	105	140

* See page A46 for cable insulation diameter ranges.

Dimensions





Dimensions	Indoor	Outdoor	Outdoor	Outdoor
Termination Catalogue Series	R2IT15	R2T15	R2T28	R2T35
Sizes Available*	1, 2, 4	1, 2, 4	2, 4	2, 4
Voltage Rating (kV)	15	15	25/28	35
Number of Sheds	0	4	6	8
Minimum Strike Distance in. (mm)	8.4 (213)	11.6 (295)	14.5 (368)	16.8 (427)
Creepage Distance in. (mm)		15.0 (381)	22.8 (579)	30.0 (762)

* See page A46 for cable insulation diameter ranges.

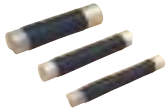

Ranger2™ Terminations Base Catalogue Numbers

The R2T and R2IT termination design couples shrink-fit technology and Elastimold's pull-down jacket seal feature to provide a termination line that covers the widest range of applications with the fewest number of models. Three sizes cover 0.64 in. (16 mm) to 2.10 in. (53 mm) insulation diameter cables (#2 AWG through 1250 kcmil).

The R2T housings are designed for maximum performance in all field conditions with superior creepage and strike distances for long-term service. Insulating silicone sleeves are also available when more creepage is required or when wildlife protection is needed to insulate the connectors. Contact your Thomas & Betts Sales Representative for further information.

	kV Class	Type	Cable Range (Insulation Diameter)		Cat. No.		
			(in.)	mm	Concentric Neutral and Jacketed Concentric Neutral Cable	Tape Shield, Wire Shield and UniShield Cable	LC Shield, Wire over Tape Shield and Tape Shield Cable
	15	Indoor	0.64 to 1.12	16.3 to 28.4	R2IT15J1	R2IT15M1	R2IT15L1
			0.84 to 1.38	21.3 to 35.1	R2IT15J2	R2IT15M2	R2IT15L2
			1.30 to 2.10	33.0 to 53.3	R2IT15J4	R2IT15M4	R2IT15L4
	15	Outdoor	0.64 to 1.12	16.3 to 28.4	R2T15J1	R2T15M1	R2T15L1
			0.84 to 1.38	21.3 to 35.1	R2T15J2	R2T15M2	R2T15L2
			1.30 to 2.10	33.0 to 53.3	R2T15J4	R2T15M4	R2T15L4
	25/28	Outdoor	0.84 to 1.38	20.3 to 35.1	R2T28J2	R2T28M2	R2T28L2
			1.30 to 2.10	33.0 to 53.3	R2T28J4	R2T28M4	R2T28L4
	35	Outdoor	0.84 to 1.38	20.3 to 35.1	R2T35J2	R2T35M2	R2T35L2
			1.30 to 2.10	33.0 to 53.3	R2T35J4	R2T35M4	R2T35L4

Ranger2™ Terminations Accessories Connector Options

	Type	Material	Conductor	Conductor Size	Connector Prefix*
	Stem Compression Connector	Aluminum	Aluminum or Copper	#2 through 4/0 (34–107 mm ²)	T0
			Aluminum Only		T1
	One-Hole Spade Connector	Tinned Aluminum	Aluminum or Copper	#2 through 500 kcmil (34–253 mm ²)	H0
	Two-Hole Spade Connector	Tinned Aluminum	Aluminum or Copper	#2 through 1250 kcmil (34–633 mm ²)	N0

* See page A48 for conductor code.

Cable Support Bracket Options

Ranger2 Terminations are compact, lightweight and frequently allow use of free-hanging mounting methods. Optional cable support brackets are available if required.

Optional Cable Support Brackets

	Type	Cable Range (in.) (Overall O.D.)	Cat. No.	Suffix No.
	Single Clamp	0.80–1.25 (20–32 mm)	JB-1	B1
	Single Clamp	1.10–1.50 (28–38 mm)	JB-2	B2
	Double Clamp	1.45–1.95 (37–50 mm)	JB-3	B3

Ranger2™ Terminations Ordering Information

How to construct a catalogue number for Ranger2 Terminations:

Step 1. Select the Termination Housing:

- A. Select Outdoor or Indoor housing style
- B. Select applicable voltage class
- C. Select neutral/shield type
- D. Select the size based on the cable insulation diameter*



Type	
Outdoor	R2T
Indoor	R2IT

kV Code	
15 kV	15
25/28 kV	28
35 kV	35

Cable Type	
J	Concentric Neutral/Jacketed Concentric Neutral
M	Tape Shield/Wire Shield/UniShield
L	LC Shield Tape Shield/Wire Over Tape Shield

Insulation Range	
1	0.64 in.–1.12 in. (16 mm–28 mm) (15 kV only)
2	0.84 in.–1.38 (21 mm–35 mm) (15 kV, 25 kV, 35 kV)
4	1.30 in.–2.10 in. (33 mm–53 mm) 15 kV, 25 kV, 35 kV)

Connector Type	
T0	Universal Aluminum Barrel for AL or CU conductor w/Copper Wire Lead #2–4/0
T1	Aluminum Barrel for AL conductor only w/Copper Wire Lead #2–4/0
H0	Aluminum 1-Hole Spade #2–750 kcmil
N0	Aluminum 2-Hole Spade #2–1250 kcmil

Cable Mounting Bracket	
B1	0.80–1.25 (20–32)
B2	1.10–1.50 (28–38)
B2	1.45–1.95 (37–50)

Conductor Code	Stranded or Compressed	Compact or Solid
210	–	#2
220	#2	#1
230	#1	1/0
240	1/0	2/0
250	2/0	3/0
260	3/0	4/0
270	4/0	250
280	250	300
290	300	350
300	350	400
310	400	500
330	500	600
360	650	750
380	750	900
400	900	1000
410	1000	–
440	1250	–

Connector Option

Step 2. Select the Connector:

- E. Select desired connector
- F. Select connector code based on conductor size and conductor type

Cable Support Bracket Option

Step 3. Select the Cable Support Bracket:

- G. Select cable support bracket based on the overall O.D. of the cable



* To help in selecting the proper terminator, ICEA and AIEC standard dimensions for XLP and EPR cables are shown in pages A35 to A37.

Ranger2™ Terminations Installation

Typical Installation of Elastimold Shrink-Fit Terminations (R2T — Outdoor and R2IT — Indoor)



1. Train the cable into position and cut to length. Using standard practices, cut back the cable jacket, metallic shield, semi-conductive shield and cable insulation, exposing the conductor.

2. Finish preparing the metallic shield. For concentric neutral or jacketed concentric neutral cables, bend back the neutral wires and seal with mastic strips and vinyl tape.

For metallic tape, drain wire, UniShield or LC Shield cables: install the ground braid using the constant force spring and seal with mastic strips and vinyl tape.

3. Clean the exposed conductor, install and crimp the connector.

4. Use mastic and vinyl tape to fill any gap or step between the connector and the cable insulation. Clean the cable.



5. Apply a liberal bead of silicone lubricant to the semi-conshield step.



6. Pull the loose end of the core cord until the core is even with the end of the termination housing.



7. Position the terminator onto the cable.



8. Shrink into place by unwinding the removable core.

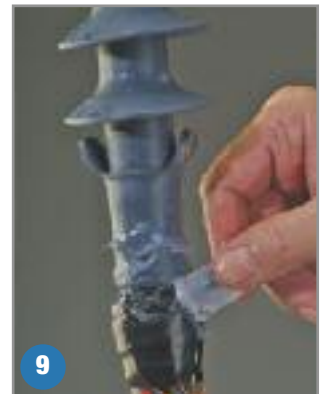

9. Apply silicone lubricant to skirt and mastic area.



10. Fold down the skirt over the mastic to seal the cable entrance.



11. Seal the top of the terminator at the connector area with silicone tape.



12. Attach the neutral wires or optional ground braid to the system ground per local code. Install the optional cable support bracket if required.

Faulted Circuit Indicators

Series 1548 Overhead FCIs

Reliable fault indication for single-phase overhead applications

FCIs with Radio Transmitters

Series 1548 radio FCIs can signal faults to handheld receivers, radio receivers and the SmartLink™ Series 5000 cellular remote terminal unit (RTU) systems integrated with SCADA and web-based reporting systems. Status, alarms and other event notifications can be integrated into SCADA systems, as well as sent to customer-designated personnel via e-mail, pager or text message. Having precise fault information reduces outage duration, improves system reliability and lowers operation costs.



Trip Logic Adaptive or fixed current trip with inrush restraint logic. Adaptive trip logic eliminates the need for trip-rating selection or revision with changing load.

Reset Logic Automatic reset with return of load current and/or time reset of permanent fault indication. Automatic time reset for temporary fault indication. Manual trip test and reset capabilities using hotstick-mountable trip/reset tool.

Fault Indication Visual indication choices of LED, 5-LED Array, Flag or Strobe Light. Highly viewable 360° indication (Strobe or LED). Radio fault reporting capability also available.

Mounting Hotstick mounting with automatic torque limiting.

Replaceable Lithium Battery Offers 10-year, maintenance-free service life. (Note that Flag model has non-replaceable battery).

Supports a Wide Range of Conductors Mounts on conductors with diameters from 0.14 in. to 1.20 in. (3.56 mm to 30.48 mm).

Optional Features Available Options include temporary/permanent fault indication, instantaneous recloser coordination feature and backfeed restraint using a delay-trip scheme (requires protective device to pass two cycles minimum of fault current before closing).

Technical Specifications

Fault Registration: Red, high-intensity LED with choice of hard-wired or fiber optic cable remote mounting or audible intermittent beeper signal

Trip current: Factory preset to customer specifications within range of 50 A and 100 A to 1,500 A in 100 A increments

Trip Current Accuracy: ±10% of trip rating (calibrated using 1 in. dia. cable for 400 A trip or less or 2.0 in. dia. cable for greater than 400 A trip)

Trip Response Speed: Consult trip curves (coordinated to properly applied link, expulsion, power and current-limiting fuses)

Reset Time: 4 hrs., 2 hrs., 1 hr., manual trip/reset standard

Overload Capacity: Capable of withstanding 25,000 A for 10 cycles

Continuous Load Current: Rated at 1,000 A max.

Temperature Range: -40°C to 85°C

Submersibility: Tested to 30 ft.

Operating Battery Life: 800 hrs. for LED indication, 160 hrs. for audible indication, both with 10-yr. life at 20°C

Battery: Long-life lithium cell

Cable Ranges: 0.63 in. (16 mm) to 1.58 in. (40 mm); 1.58 in. (40 mm) to 2.36 in. (60 mm); 2.36 in. (60 mm) to 3.55 in. (90 mm)

Remote Fiber Optic Options: Permanent or removable (10 ft. standard, 30 ft. max.)

Certifications: Complies with ANSI/IEEE 495-1986



Trip/Reset Tool AT2186-10

Manual trip/reset test for both permanent and temporary fault indication using hotstick-mountable reset tool.

Faulted Circuit Indicators

Underground/Padmount Faulted Circuit Indicators Series 1541/42/43 Automatic Time Reset FCIs

The following diagram shows how to construct a catalogue number for Series 1541/1542/1543 FCIs. Not all combinations are possible; consult your Regional Sales Office for ordering assistance.

Indicates field that must be filled in to complete order.

NOTE: Availability of selected configuration will be verified at quotation time.

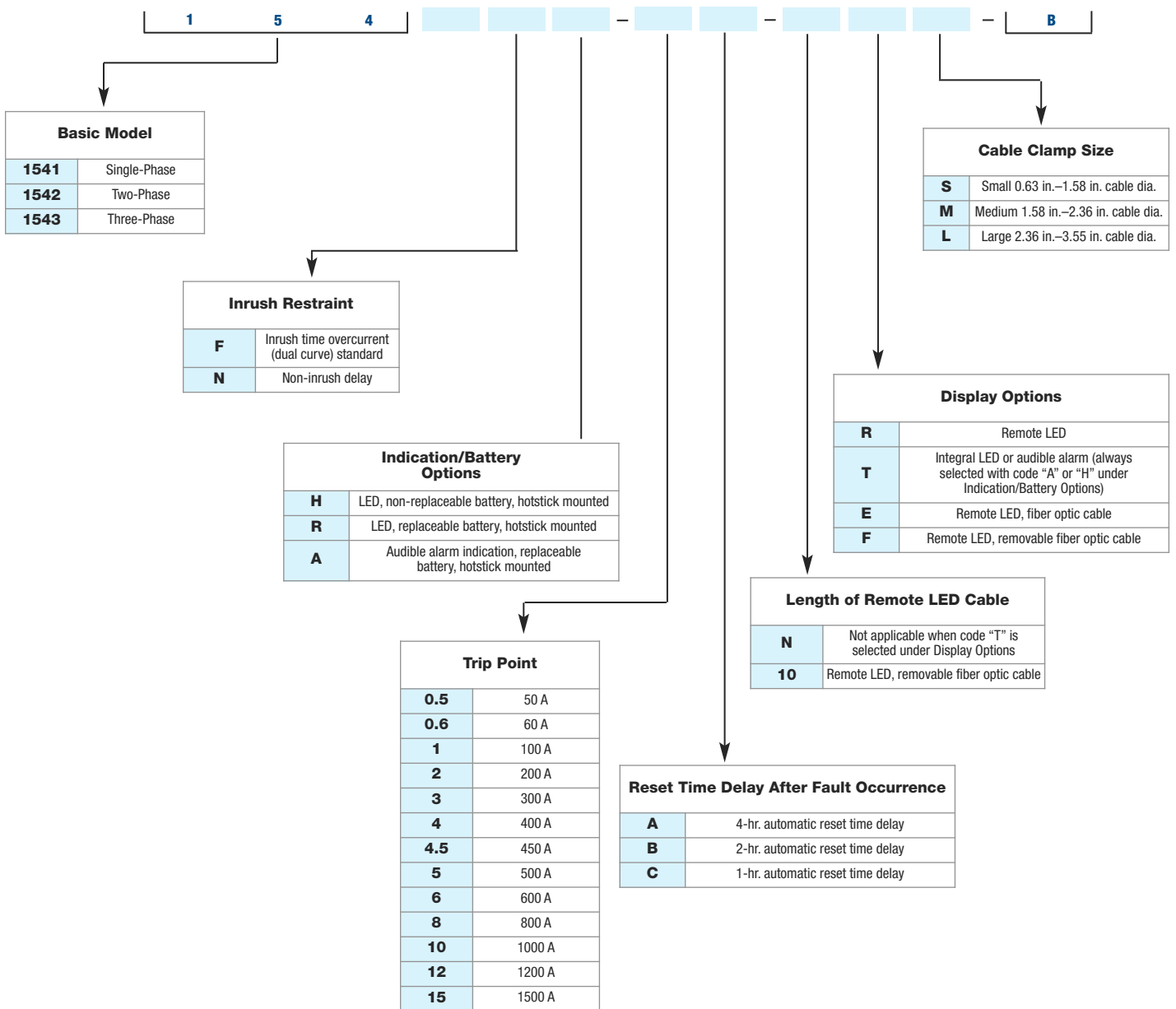

Faulted Circuit Indicators

Test Point Fault Indicators TPM Series

Mount directly to any IEEE 386 standard capacitive test point.

Test Point Mounted Fault Indicators consist of a solid-state current sensor connected to a faulted-circuit display, providing a clear visual means for quickly locating faulted cables and equipment on underground distribution systems. Designs incorporate advanced circuit logic and monitoring system protection operation to prevent the indicator from tripping unless an overcurrent condition is followed by a loss of system voltage. Trip and reset operations are automatic, and for versatility and convenience, the same indicator may be used for 5 kV thru 35 kV applications.

AccQTrip™ Logic Circuitry Prevents false indications in voltage-reset units due to inrush currents, cold load pickup and overloading.

High/Low Trip-Setting Selection Requires no minimum load current and no load surveys.

Internal Magnetic Shielding Prevents adjacent phase effects.

1 msec. Trip Response Coordinates with current-limiting fuses, as well as other protection devices.

Magnetically Latched Flag Prevents flag indication from changing state due to shock or vibration.

Test Point Mounting Mounts directly to 200 and 600 A elbows, splices and other cable accessories equipped with IEEE 386 standard capacitive test points.

Built-In Pulling Eye Enables safe, easy hotstick installation and removal from test points.

Durable Construction Enclosed in a rugged, yet lightweight and compact, sealed, impact- and corrosion resistant Lexan housing with EPDM molded-rubber test point mounting boot.

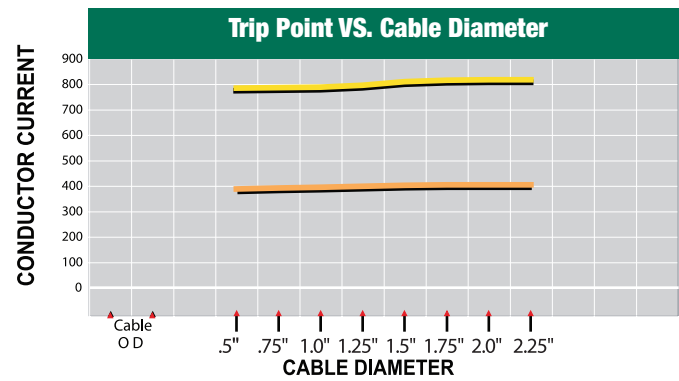
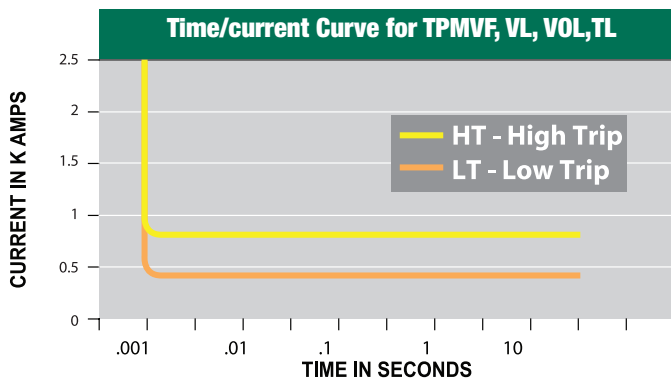

Basic Operation

A faulted circuit produces an associated magnetic field, which closes a reed switch in the indicator, resulting in a tripped display. Trip response occurs in .001 seconds (1 msec.), allowing the fault indicator to properly coordinate with all types of circuit-protection schemes, including current limiting fuses. To eliminate confusing false trips, voltage-reset indicators are equipped with inrush, backfeed, overload and cold-load pick-up restraint circuitry. Current sensors feature internal shielding to prevent inadvertent tripping when located in close proximity to adjacent phases, such as in junction-mounted applications.

Faulted Circuit Indicators

Test Point Fault Indicators TPM Series

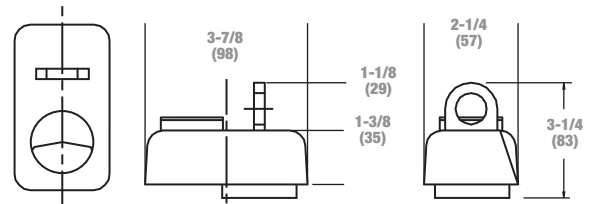
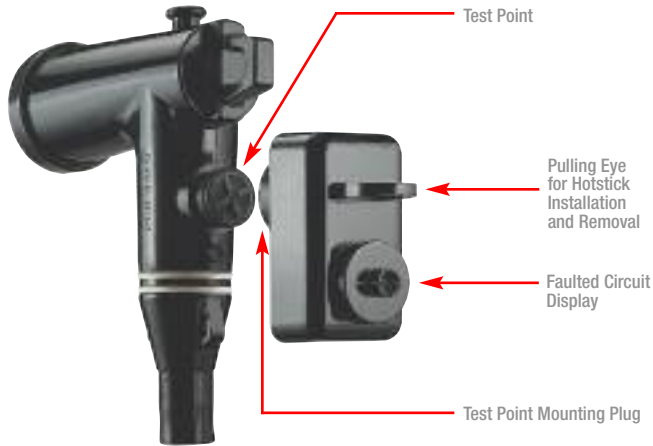

(all dimensions (in.) with millimeter equivalents in parentheses)

Cat. No.	Description
TPMTL-[_]	Time Reset with LED Display (auto-resets to normal after 4 hrs.; may also be manually reset using an FIT test tool)
TPMVF-[_]	Voltage Reset with Flag Display (auto-resets to normal after system voltage restoration; reset requires 5 kV min. voltage with time required for reset proportional to system voltage)
TPMVL-[_]	Voltage Reset with LED Display (auto-resets to normal after system voltage restoration; reset requires 5 kV min. voltage with time required for reset proportional to system voltage)
TPMVOL-[_]	Voltage Operated, Time Reset, LED Display (auto-resets after 4 hrs.; longer time resets available upon request)
Cat. No. Suffix	Description
-LT	For 200 A. All fused taps use LOW trip rating. For URD applications, use LOW trip rating.
-HT	For 600 A. For URD applications, use HIGH trip rating.

NOTE: For overhead bulk feeder applications, use HIGH or LOW trip ratings (whichever is greater than the minimum pickup setting of the related protection device). AccQTrip™ and AccQClamp™ are trademarks of Quality Indications, Inc.

Faulted Circuit Indicators

Overhead Line Fault Indicators OLM Series

Locate faulted circuits and equipment on overhead distribution systems

Self-powered Fisher Pierce® Series OLM Overhead Line Fault Indicators consist of a solid-state current sensor connected to a faulted circuit display. Advanced circuit logic monitors system protection operation and prevents indicator tripping unless an overcurrent condition is followed by a loss of system voltage. Trip and reset operations are automatic, and the same indicator may be used for 5 kV thru 35 kV line-to-ground applications. These compact, sealed and corrosion-resistant units are designed for direct installation to an overhead line using a spring-loaded, over-center toggle clamp. Equipped with retainer pads to prevent slip and twist, the clamp positions the conductor at a constant distance from the current sensor, maintaining trip accuracy over the entire conductor diameter range of .4 in. to 2.2 in.

Basic Operation

A faulted circuit produces a magnetic field, which closes a reed switch in the indicator and causes a tripped display. A trip response time of .001 seconds enables the indicator to properly coordinate with all circuit-protection schemes, including current-limiting fuses. To eliminate confusing false trips, indicators feature inrush, overload and cold-load pickup restraint circuitry as standard. Internal shielding of current sensors prevents inadvertent tripping when in close proximity to adjacent phases.

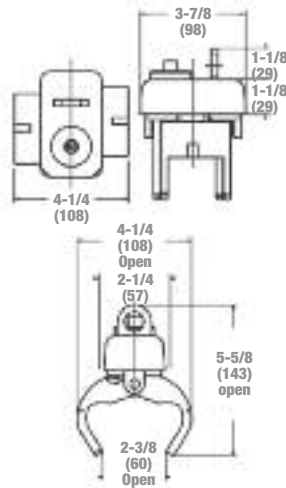

AccQTrip™ Logic Circuitry In voltage reset units prevents false indications due to inrush currents, cold load pickup and overloading.

AccQClamp™ Mounting Provision Universal one-size-fits-all design automatically adjusts.

High/Low Trip Setting Selection No minimum load current requirement and no load surveys needed.

Trip Response of .001 Seconds Coordinates with current-limiting fuses, as well as other protection devices.

Internal Magnetic Shielding Prevents adjacent phase effects.

Magnetically Latched Flag Indication Flag indication will not change states due to shock or vibration.

Lightweight Enclosure Compact and sealed.

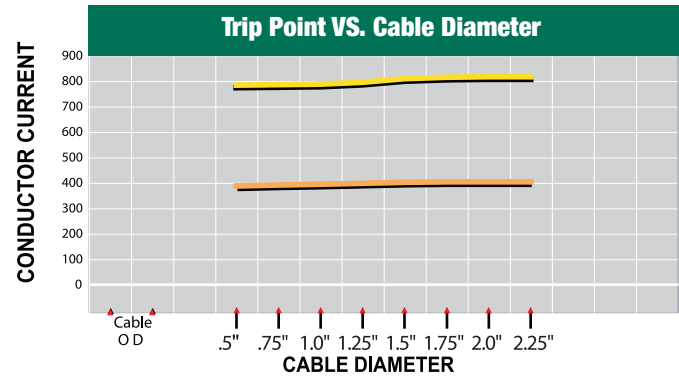
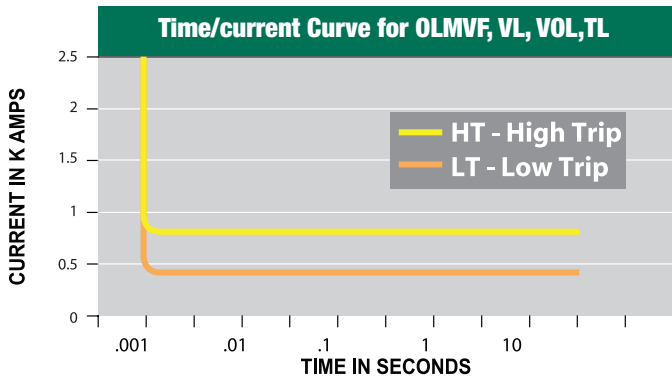

Faulted Circuit Indicators

Overhead Line Fault Indicators OLM Series

Cat. No.	Description	Reset Operation
OLMTL	Time Reset with LED Display	Indicator auto-resets to normal after a four hour time duration. indicator may also be manually reset using an FTT test tool.
OLMVF	Voltage Reset with Flag Display	Indicator auto-resets to normal after system voltage restoration. Reset requires 5 kV minimum voltage to operate. Reset operation time is proportional to system voltage.
OLMVL	Voltage Reset with LED Display	Example: at 15 kV, reset occurs 30 seconds after system voltage restoration.
OLMVOL	Voltage Operated, Time Reset, LED Display	Indicator auto-resets after a four hour time duration. Longer time resets are available upon request.
Cat. No. Suffix	Description	
LT	All fused taps use LOW trip rating. For 600 A Overhead applications, use LOW trip rating.	
HT	For 600 A Overhead applications, use HIGH trip rating.	

Accessories for Series TPM, VCM and OLM Fault Indicators

FO-Cable06

Remote Fiber Optic Indicator for Underground Fault Indicators with LED Display can be extended to the outside of enclosures and/or vaults for ease of access and fault location. All the hardware for mounting the remote end of the cable to the enclosure is included. The display has a large reflective bolt to enhance visibility.

FTT (Field Test Tool)

Permits field testing and reset of fault indicators and provides assurance that the indicator is properly functioning. The test tool is lightweight, portable and incorporates a built-in magnet which operates the indicator trip and reset functions. The unit is equipped with provisions for hotstick handling and operation.



Cat. No.	Description
FTT	Field Test Tool, overall dimensions 2 in. wide x 3 in. high x 5/8 in. deep
FO-CABLE06	Remote Fiber Optic Indicator for UFI

Faulted Circuit Indicators

Test Point V2 Voltage Indicator

Easy way to visually determine the energized status of underground distribution circuits

The V2 Voltage Indicator consists of a self-powered voltage sensor connected to a neon light that flashes when energized. Simply plug it into any IEEE 836 standard capacitive test point to determine the energized status of underground distribution circuits. Because the flash rate is proportional to the phase-to-phase system voltage, as indicated in the chart, one V2 model supports a wide range of applications – from 5 to 35 kV.

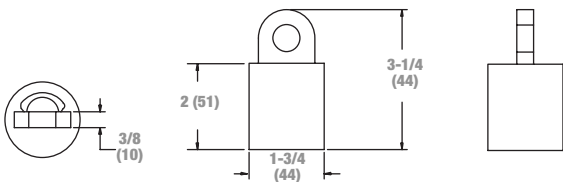
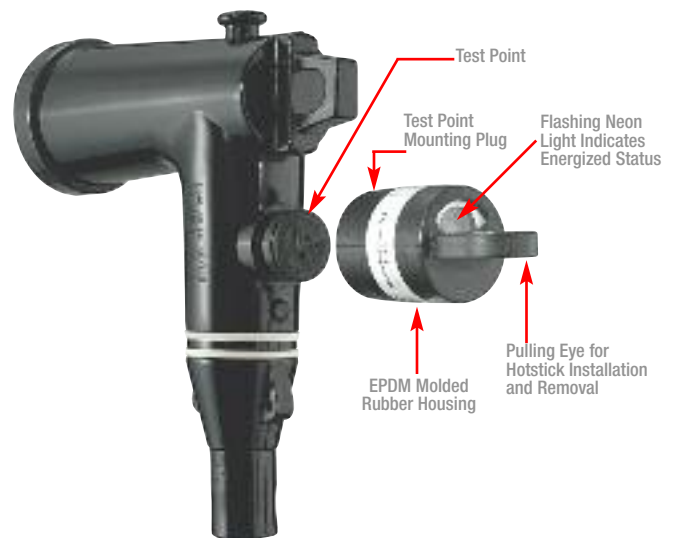

(all dimensions in inches with millimeter equivalents in parentheses)

Voltage	Flash Rate
5 kv	20
10 kv	40
15 kv	70
20 kv	100

Voltage	Flash Rate
25 kv	140
30 kv	160
35 kv	180

Faulted Circuit Indicators

Test Point V2 Voltage Indicator (cont'd)

Wide Application Range Single model supports applications from 5 kV to 35 kV.

Easy to Read Flash rate per minute indicates system voltage (see chart).

IEEE 386 Test Interface Mounts to 200 and 600 A elbows, splices and other cable accessory components equipped with IEEE 386 capacitive test points.

Rugged Construction Molded EPDM-rubber housing for shielded, sealed and corrosion-resistant construction.

Built-In Pulling Eye Enables safe, easy hotstick installation and removal from test point.

20-Year Neon Bulb Yields long, maintenance-free service life.

Testable with V2-TB Easily tested for confirmation of proper operation with the V2-TB voltage indicator test box.

V2-TB Test Box for easy field testing of V2 Voltage Indicators

If the V2 Neon Voltage Indicator indicates a power failure in an underground distribution circuit, you'll want to ensure that it's actually the circuit that's failed and not the V2 itself. For fast, simple assurance, field test the V2 with the compact, portable V2-TB Voltage Indicator Test Box, powered by replaceable C batteries.



Cat. No.	Description
V2	Voltage Indicator with Neon Display
V2-TB	Voltage Indicator Test Box

Underground Distribution Switchgear

Molded Vacuum Switches and Fault Interrupters

MVS Molded Vacuum Switches

Spring-energy, load-switching devices that make, carry and interrupt load currents through 600 A on 5 to 38 kV distribution systems.

MVS Molded Vacuum Switches include molded-in elbow connection interfaces and spring-energy mechanisms. Available in both single- and three-phase models, units are manually operated with a hotstick. Motor operator, SCADA and auto-transfer control options are available.

EPDM Molded Rubber Insulation MVSs are fully sealed and submersible.

Vacuum Switching and Vacuum Interruption Components are maintenance-free and require no gas or oil.

Compact and Lightweight Small footprint enables MVSs to fit in tight padmount, subsurface, vault or riser pole installations.

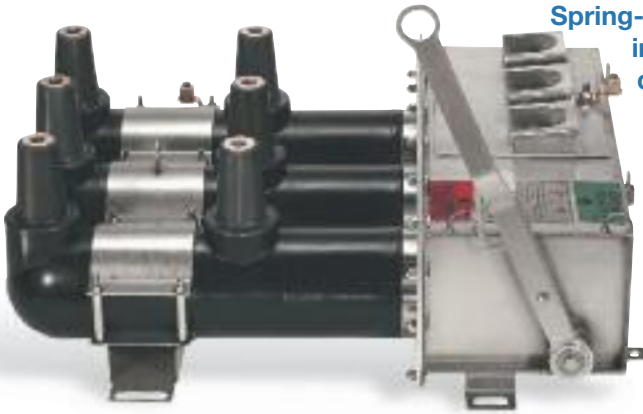

Single-Phase Switches Approximate Weight: 30 lb.

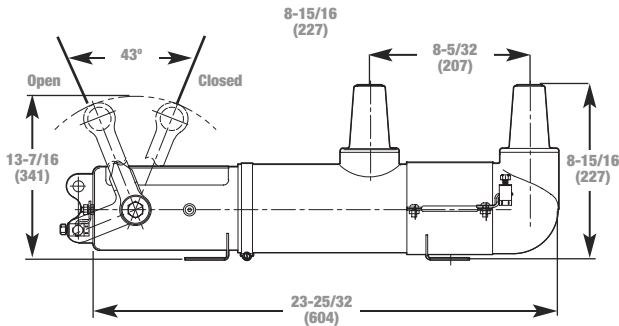
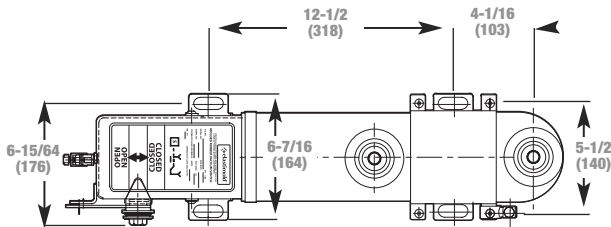

(4) Mounting Holes, 5/8 in. Dia. x 7/8 in. (16 x 22 mm)

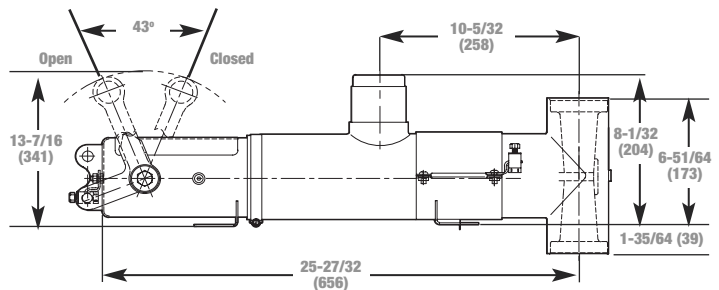
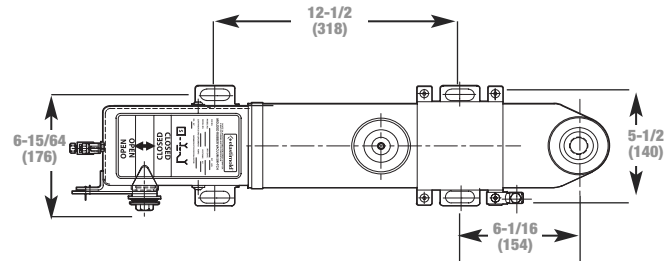

(4) Mounting Holes, 5/8 in. Dia. x 7/8 in. (16 x 22 mm)

Available with 600 A one-piece bushings or 200 A wells on either/both terminals.

Underground Distribution Switchgear

Molded Vacuum Switches and Fault Interrupters

Three-Phase Switches
Approximate Weight: 135 lb.

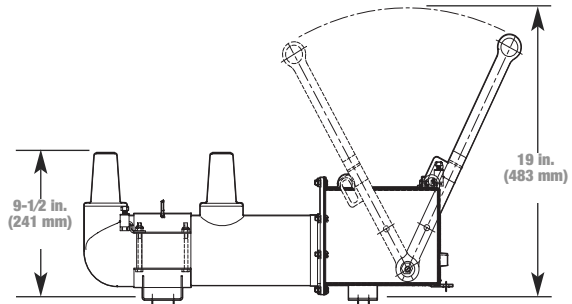
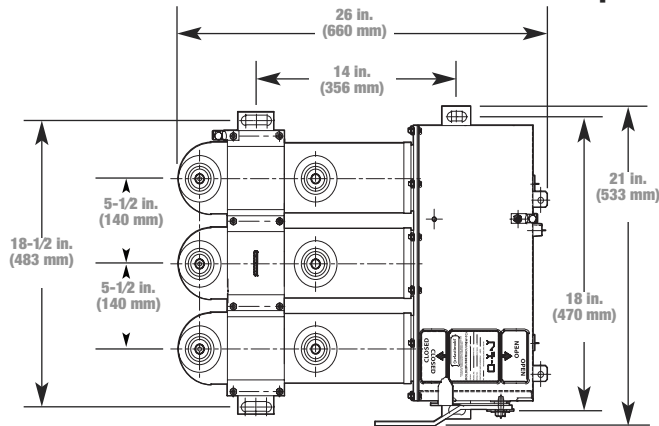

Available with 600 A one-piece bushings or 200 A wells on either/both terminals.

Ratings

Maximum Design Voltage (kV)	15.5	27	38
Frequency (Hz)	50/60	50/60	50/60
BIL Impulse (kV)	95	125	150
One-Minute AC Withstand (kV)	35	60	70
Fifteen-Minute DC Withstand (kV)	53	78	103
Load Interrupting & Loop Switching (Amp)	600	600	600
Transformer Magnetizing Interrupting (Amp)	21	21	21
Capacitor or Cable Charging Interrupting (Amp)	40	40	40
Asymmetrical Momentary and 3-Operation Fault Close (Amp)	20	20	20
Symmetrical One-Second Rating (Amp)	12,5	12,5	12,5
Continuous Current (Amp)	600	600	600
Eight-Hour Overload Current (Amp)	900	900	900

Application Information

- Construction: Submersible, corrosion resistant, fully shielded
- Ambient Temperature Range: -40°C to 65°C

Certified Tests

MVS loadbreak switches have been designed and tested per applicable portions of IEEE, ANSI, NEMA and other industry standards, including:

- IEEE C37.74** Standard for Subsurface, Vault and Padmounted Load-Interrupting Switches
- IEEE 386** Standard for Separable Connectors and Bushing Interfaces
- IEC 265** International Standards for Load-Interrupting Switches
- ANSI C57.12.28** Standard for Padmount Enclosures

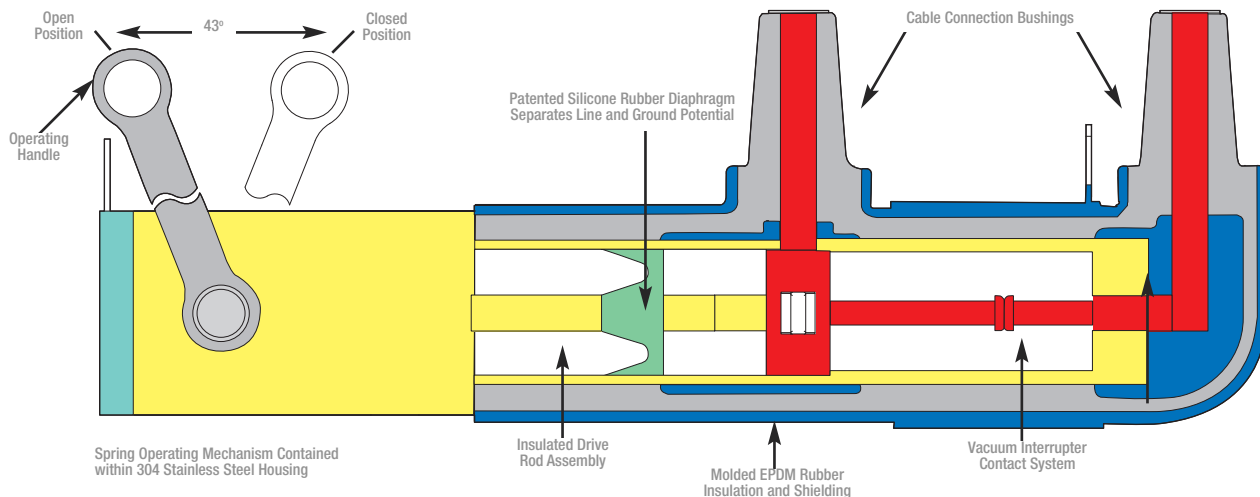



Underground Distribution Switchgear

MVI Molded Vacuum Fault Interrupters

Make, carry and automatically interrupt currents through 25,000 A symmetrical on 5 to 38 kV distribution systems

MVI Molded Vacuum Fault Interrupters include molded-in elbow connection interfaces and tripfree mechanisms. They are available in single- and three-phase models. Units are self-powered and include current-sensing and electronic control.

Combines Vacuum Interrupters, Programmable, Electronic, Self-Powered Controls and EPDM Rubber Insulation

Components provide compact, lightweight and submersible overcurrent protection.

Field Programmable with a Wide Range of Time-Current Characteristic (TCC) Curves and Trip Settings

TCC curves provide predictable tripping for ease of coordination with upstream and/or downstream protective devices.

Control Monitors the Circuit Condition

When the programmed parameters are exceeded, a signal is sent to the tripping mechanism.

Motor Operators and Controls Available

Enable radial feeders or loops to be reconfigured, either manually or via SCADA.

Front View Single-Phase

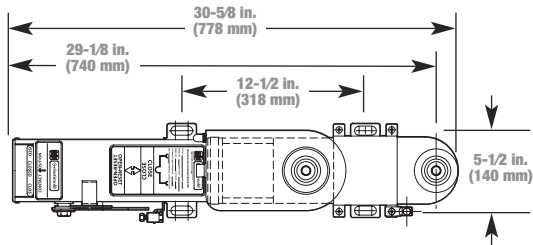

200 A Wells

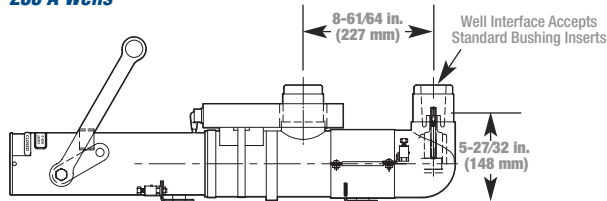

600 A Bushings

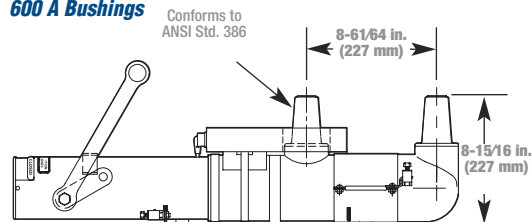

Front View Three-Phase

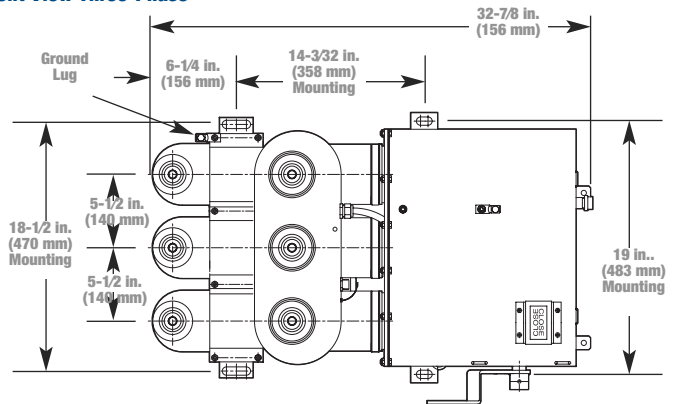

600 A T Elbow Interface

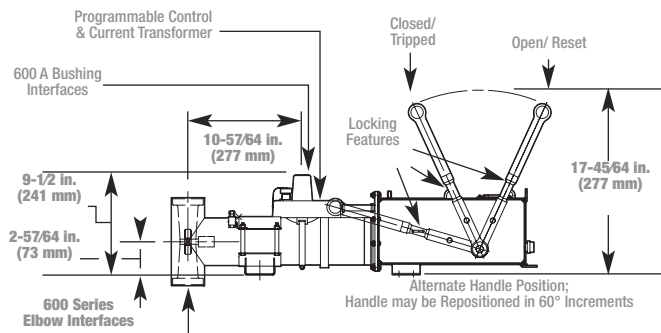

Underground Distribution Switchgear

MVI Molded Vacuum Fault Interrupters

Ratings

Voltage Class (kV)	15.5	15.5	15.5	27	35	35
Maximum Design Voltage (kV)	17	17	15.5	29	38	38
Frequency (Hz)	50/60	50/60	50/60	50/60	50/60	50/60
BIL Impulse Withstand (kV)	95	95	95	125	150	150
One-Minute AC Withstand (kV)	35	35	35	60	70	70
Five-Minute DC Withstand (kV)	53	53	53	78	103	103
Continuous Current (A)	600	600	600	600	600	600
Load Interrupting and Loop Switching (A)	600	600	600	600	600	600
Transformer Magnetizing Interrupting (A)	21	21	21	21	21	21
Capacitor or Cable Charging Interrupting (A)	40	40	40	40	40	40
Symmetrical/Asymmetrical Interrupting Capability (kA)	12.5/20	16/25.6	20/32	12.5/20	12.5/20	25/40
Current Sensor Ratio	1,000:1	1,000:1	1,000:1	1,000:1	1,000:1	1,000:1

Application Information

- Meets ANSI C37.60 requirements
- Ambient Temperature Range: -40°C to 65°C

Certified Tests

MVI Molded Vacuum Fault Interrupters have been designed and tested per applicable portions of IEEE, ANSI, NEMA and other industry standards, including:

ANSI C37.60 Standard for Fault Interrupters

IEEE 386 Standard for Separable Connectors and Bushing Interfaces

ANSI C57.12.28 Standard for Padmounted Enclosures

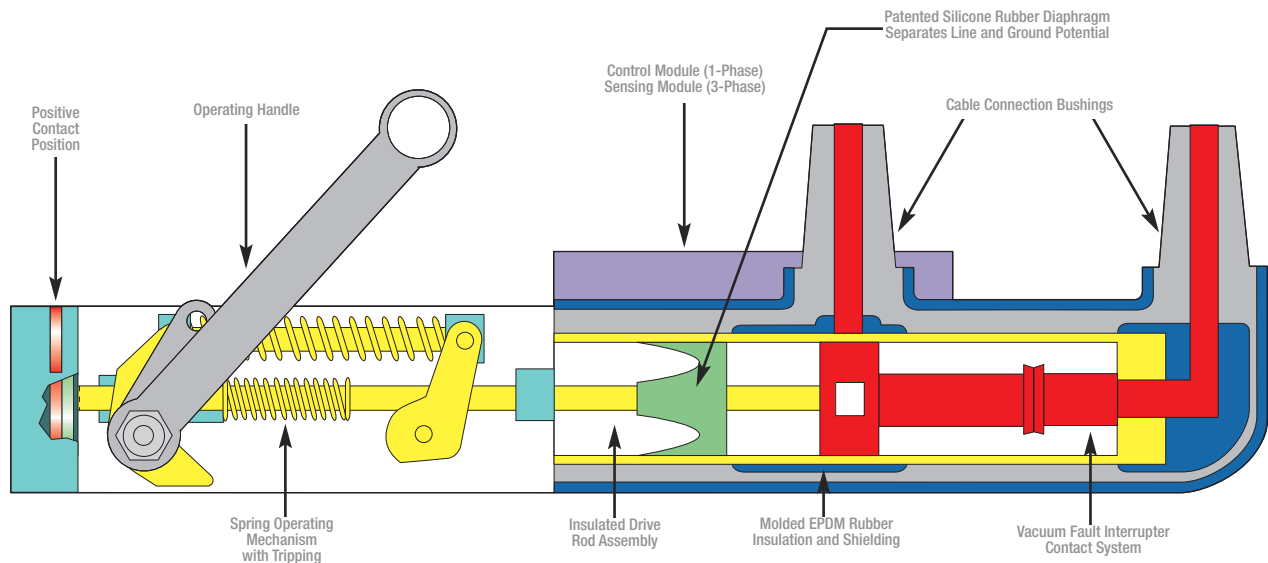

Underground Distribution Switchgear

Molded Vacuum Switches and Fault Interrupters

Choose from five electronic control options to interrupt faults

Molded Vacuum Interrupters are provided with self-powered electronic control packages requiring no batteries or external power. Depending on the application, five electronic control options are available for the MVI — see below and on following page.

Include Self-Powered Electronic Control Packages No batteries or external power are required. Controls send a signal to the vacuum interrupters to trip open and interrupt the fault when an overcurrent condition is detected.

Field-Selectable Fuse or Relay Curves and Trip Settings One device for many protection schemes.

Internal Control

This control is integral to the unit (no separate control box). It is accessible via a computer connection to view or modify settings. This control is used on ganged three-phase or single-phase MVI interrupters. Phase and ground trip, as well as inrush restraint, are available. The E-Set software enables the user to connect to the internal control, either in the shop or in the field, to program or change settings. An MVI-STP-USB programming connector is required to connect between the PC and the MVI. With a computer connected to the MVI control, the user can view real-time currents, the number of over-current protection operations, current magnitude of the last trip and the phase/ground fault targets. This is the standard control option.

NOTE: E-Set can be downloaded from www.elastimoldswitchgear.com



External Control with Single-/Three-Phase Trip Selection (Style 10 and 310)

This control is mounted externally to the mechanism and provides the ability to select TCCs by setting DIP switches on the front panel. Each phase can be assigned a different minimum trip setting by means of manual rotary switches. This control is used on one, two or three single-phase MVI mechanisms.



External Control with Phase and Ground Trip (Style 20 and 320)

This control is mounted externally to the mechanism and provides the ability to select phase minimum trip (one for all three phases), time delay for phase tripping, ground trip as a percent of phase minimum trip and ground trip delay by means of manual rotary switches. This control may be used on ganged three-phase or three single-phase MVI mechanisms.



Underground Distribution Switchgear

Molded Vacuum Switches and Fault Interrupters

External Control with Three-Phase Trip Only (Style 30 and 330)

This control is mounted externally to the mechanism and provides the ability to select phase minimum trip (one for all three phases) by means of a manual rotary switch. It also has an RS-232 port for connection to a PC to view the last trip data. This control is used on ganged three-phase or three single-phase MVI mechanisms.



External Control with Selectable Single-/Three-Phase Trip Function (80 and 380 Control)

This control is mounted externally to the mechanism of the interrupter and provides the ability to select between a single-phase trip and a three-phase trip. The 80 and 380 Control can be used with one three-phase interrupter or with three single-phase interrupters. For three-phase applications, the ground trip function can be blocked from the front panel. Manual trip and reset target buttons are also located on the front panel. This control uses the E-Set software, which enables programming via a computer using the MVI-STP-USB adapter. E-Set features custom TCC curves and provides access to the last fault event information, as well as real-time current per phase.



Curve Reference No.	Curve No.	Curve Type
Relay Curves (minimum trip 30–600A)		
MVI-TCC-01	1	E Slow
MVI-TCC-02	2	E Standard
MVI-TCC-03	3	Oil Fuse Cutout
MVI-TCC-04	4	K
MVI-TCC-05	5	Kearney QA
MVI-TCC-06	6	Cooper EF
MVI-TCC-07	7	Cooper NX-C
MVI-TCC-08	8	CO-11-1
MVI-TCC-09	9	CO-11-2
MVI-TCC-10	10	T
MVI-TCC-11	11	CO-9-1
MVI-TCC-12	12	CO-9-2
MVI-TCC-13	13	Cooper 280ARX
MVI-TCC-14	14	F
MVI-TCC-16	16	Kearney KS
MVI-TCC-17	17	GE Relay
MVI-TCC-18–23	18–23	CO-8-1–CO-8-6
MVI-TCC-24–27	24–27	CO-9-3–CO-9-6
MVI-TCC-28–31	28–31	CO-11-3–CO-11-6

Curve Reference No.	Curve No.	Curve Type
Fuse Curves (minimum trip 10–200A)		
MVI-TCC-54	54	E Slow
MVI-TCC-55	55	E Standard
MVI-TCC-56	56	Oil Fuse Cutout
MVI-TCC-57	57	K
MVI-TCC-58	58	Kearney QA
MVI-TCC-59	59	Cooper NX-C
MVI-TCC-60	60	T

Underground Distribution Switchgear

Molded Vacuum Switches and Fault Interrupters

The following diagram shows how to construct a catalogue number for Molded Vacuum Switches and Interrupters. Catalogue numbers are shown below.

EXAMPLE: The catalogue number for a Molded Vacuum Interrupter on a three-phase, 27 kV system, with 600 A terminal and parking stands between bushings is **MVI3-21-27-66-PS**.

Note: Availability of selected configuration will be verified at quotation time.

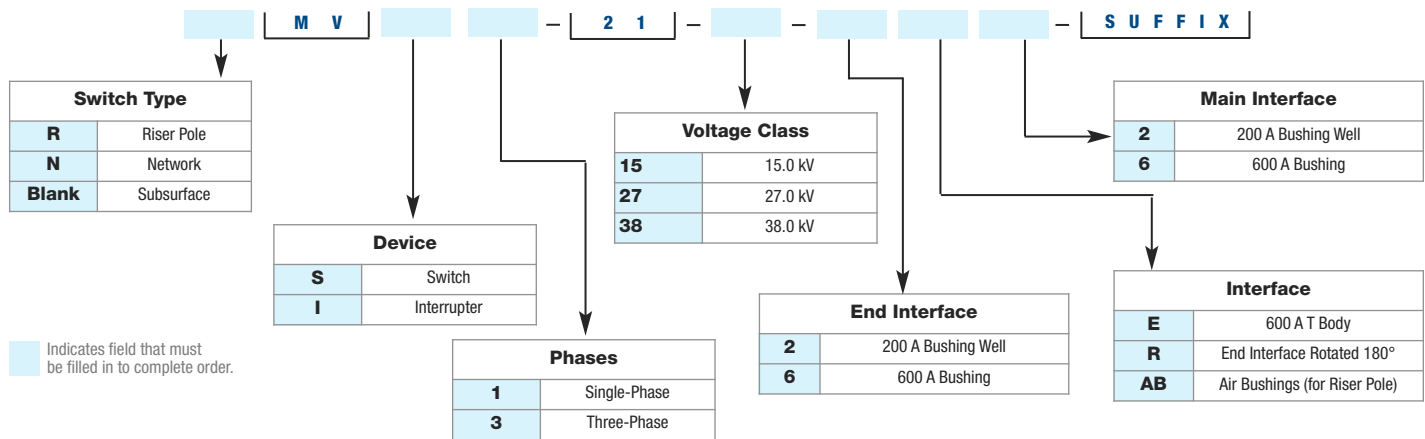

Controls and Accessories

Cat. No. Suffix	Description
20	External 20 Control with Phase and Ground Trip (to be used on ganged three-phase MVI mechanism)
30	External 30 Control with Three-Phase Trip Only (to be used on ganged three-phase MVI mechanism)
80	External 80 Control with Selectable Single-/Three-Phase Trip Function (to be used on ganged three-phase MVI mechanism)
110	External 10 Control with Single Trip Selection (to be used on one single-phase MVI mechanism)
310	External 10 Control with Single-/Three-Phase Trip Selection (to be used on three single-phase MVI mechanisms)
320	External 20 Control with Phase and Ground Trip (to be used on three single-phase MVI mechanisms)
330	External 30 Control with Three-Phase Trip Only (to be used on three single-phase MVI mechanisms)
380	External 80 Control with Selectable Single-/Three-Phase Trip Function (to be used on three single-phase mechanisms)
MO120A	120VAC Motor Operator and Controller for MVS3 or MVI3 Units
MO12D	12-24VDC Motor Operator and Controller for MVS3 or MVI3 Units
PS	Parking Stand for MVS or MVI (between bushings for single- or three-phase units)
MPS	Parking Stand for MVS3, MVI3 or RMVI3 on Mechanism Cover
PS6	Double Parking Stand for MVS3, MVI3 or RMVI3 (between bushings and on mechanism cover)
BT	Bail Tab Plate Installed for Three-Phase Units Only
P	Customer Settings to be Programmed at the Factory

Leave suffix blank for internal (self-contained) control.

MVS Molded Vacuum Switches

Cat. No.	Description	Width in. (mm)	Height in. (mm)	Depth in. (mm)	Weight lb. (kg)	Diagram
Single-Phase Vacuum Switches						
MVS1-21-15-XX	15 kV 2-Way 1-Phase Switch	6 (152)	24 (610)	14 (356)	30 (14)	*
MVS1-21-15-6EX	15 kV 2-Way 1-Phase Switch — Elbow Interface			15 (381)		
MVS1-21-27-XX	25 kV 2-Way 1-Phase Switch			14 (356)		
MVS1-21-27-6EX	25 kV 2-Way 1-Phase Switch — Elbow Interface			15 (381)		
MVS1-21-38-XX	35 kV 2-Way 1-Phase Switch			14 (356)		
Three-Phase Vacuum Switches						
MVS3-21-15-XX	15 kV 2-Way 3-Phase Switch	21 (533)	26 (660)	19 (483)	135 (61)	*
MVS3-21-27-XX	25 kV 2-Way 3-Phase Switch					
MVS3-21-38-XX	35 kV 2-Way 3-Phase Switch					

* Height includes handle. ** 3-Phase Vacuum Switches are motor-ready.

Underground Distribution Switchgear

MVI Molded Vacuum Interrupters***

Cat. No.	Description	Width in. (mm)	Height in. (mm)	Depth in. (mm)	Weight lb. (kg)	Diagram
Riser Pole (Three-Phase Installations Only)						
RMVI3-21-15-6ABX-YY	15kV 2-Way 3-Phase Interrupter with Air Bushings on Top Terminals	30 (762)	45 (1,143)	25 (635)	150 (68)	
RMVI3-21-27-6ABX-YY	25kV 2-Way 3-Phase Interrupter with Air Bushings on Top Terminals	30 (762)	45 (1,143)	25 (635)	150 (68)	
RMVI3-21-38-6ABX-YY	38kV 2-Way 3-Phase Interrupter with Air Bushings on Top Terminals	30 (762)	45 (1,143)	25 (635)	150 (68)	
RMVI1-21-15-6ABX-3YY	15kV 2-Way 3-Phase Interrupter with Air Bushings on Top Terminals, 1-Phase Trip Selectable	30 (762)	45 (1,143)	25 (635)	150 (68)	
RMVI1-21-27-6ABX-3YY	27kV 2-Way 3-Phase Interrupter with Air Bushings on Top Terminals, 1-Phase Trip Selectable	30 (762)	45 (1,143)	25 (635)	150 (68)	
RMVI1-21-38-6ABX-3YY	38kV 2-Way 3-Phase Interrupter with Air Bushings on Top Terminals, 1-Phase Trip Selectable	30 (762)	45 (1,143)	25 (635)	150 (68)	
Subsurface Single-Phase Vacuum Switches						
MVI1-21-15-XX	15kV 2-Way 1-Phase Interrupter	6 (152)	31 (787)	9 (229)	45 (20)	
MVI1-21-15-6EX	15kV 2-Way 1-Phase Interrupter, Elbow Interface	6 (152)	31 (787)	11 (279)	45 (20)	
MVI1-21-27-XX	27kV 2-Way 1-Phase Interrupter	6 (152)	31 (787)	9 (229)	45 (20)	
MVI1-21-27-6EX	27kV 2-Way 1-Phase Interrupter, Elbow Interface	6 (152)	31 (787)	11 (279)	45 (20)	
MVI1-21-38-XX	38kV 2-Way 1-Phase Interrupter	6 (152)	31 (787)	9 (229)	45 (20)	
MVI1-21-38-6EX	38kV 2-Way 1-Phase Interrupter, Elbow Interface	6 (152)	31 (787)	11 (279)	45 (20)	
Subsurface Three-Phase Vacuum Switches						
MVI1-21-15-XX-3YY	15kV 2-Way 3-Phase Interrupter, 1-Phase Trip Selectable Ext. Control	20 (508)	31 (787)	9 (229)	145 (66)	
MVI1-21-27-XX-3YY	27kV 2-Way 3-Phase Interrupter, 1-Phase Trip Selectable Ext. Control	20 (508)	31 (787)	9 (229)	145 (66)	
MVI1-21-38-XX-3YY	38kV 2-Way 3-Phase Interrupter, 1-Phase Trip Selectable Ext. Control	20 (508)	31 (787)	9 (229)	145 (66)	
MVI3-21-15-XX-YY	15kV 2-Way 3-Phase Interrupter	20 (508)	33 (838)	10 (254)	145 (66)	
MVI3-21-27-XX-YY	27kV 2-Way 3-Phase Interrupter	20 (508)	33 (838)	10 (254)	145 (66)	
MVI3-21-38-XX-YY	38kV 2-Way 3-Phase Interrupter	20 (508)	33 (838)	10 (254)	145 (66)	

***Air bushings on top terminal.

Accessories (order separately)

Cat. No.	Description
MVI-STP-USB	Adapter for Connection between MVI Units with Internal Control and a Computer for Programming/Viewing Settings
MV1PMB	Pole-Mounting Bracket for 1-Phase Units Only
MV3PMB	Pole-Mounting Bracket for 3-Phase Units Only
MV3HPMB	Horizontal Pole-Mounting Bracket for 3-Phase Units Only
MV13PMB	Pole-Mounting Bracket for Three 1-Phase Units Only
35AL-11	Connector Bare Wire Type 3/4"-16 Rod for Riser Pole Units Qty. of 1 Needed per Phase
35AL-12	Connector 2-Hole Spade Type 3/4"-16 Rod for Riser Pole Units Qty. of 1 Needed per Phase
MVI-TESTER	Tester for Electric Control Style 80

Weights and dimensions are approximate.
 X = 6 for 600A or 2 for 200A or 6E for 600A T interface.
 Y = 10, 20, 30, 80 for different electronic controls.
 Leave blank for internal (self-contained) control.

Accessories should be added as suffix to the main catalog number unless otherwise noted.
 Other configurations are available. Please consult your local representative on configurations not shown here.
 The 3-Phase Vacuum Interrupters are motor-ready.

Underground Distribution Switchgear

Multi-Way Switchgear and Transfer Packages

Multi-Way Unit Construction

Multi-way vault and padmount units are built using MVS, MVI and MCAN modules as required by the application. These are mounted onto the ES multi-way common bus system and assembled on a free-standing, floor-mounted frame. At this stage, the product is ready to be used in vault installations.

For padmount installations, a double-sided, drop-over, painted, mild steel enclosure is provided. Munsell Green 7GY 3.29/1.5 is the standard enclosure color. Other colors are available upon request. Painted stainless steel or fiberglass enclosures are available as options.



Common Bus Assembly



Vault-Style Unit



Padmount Unit: Tap (Load) Side

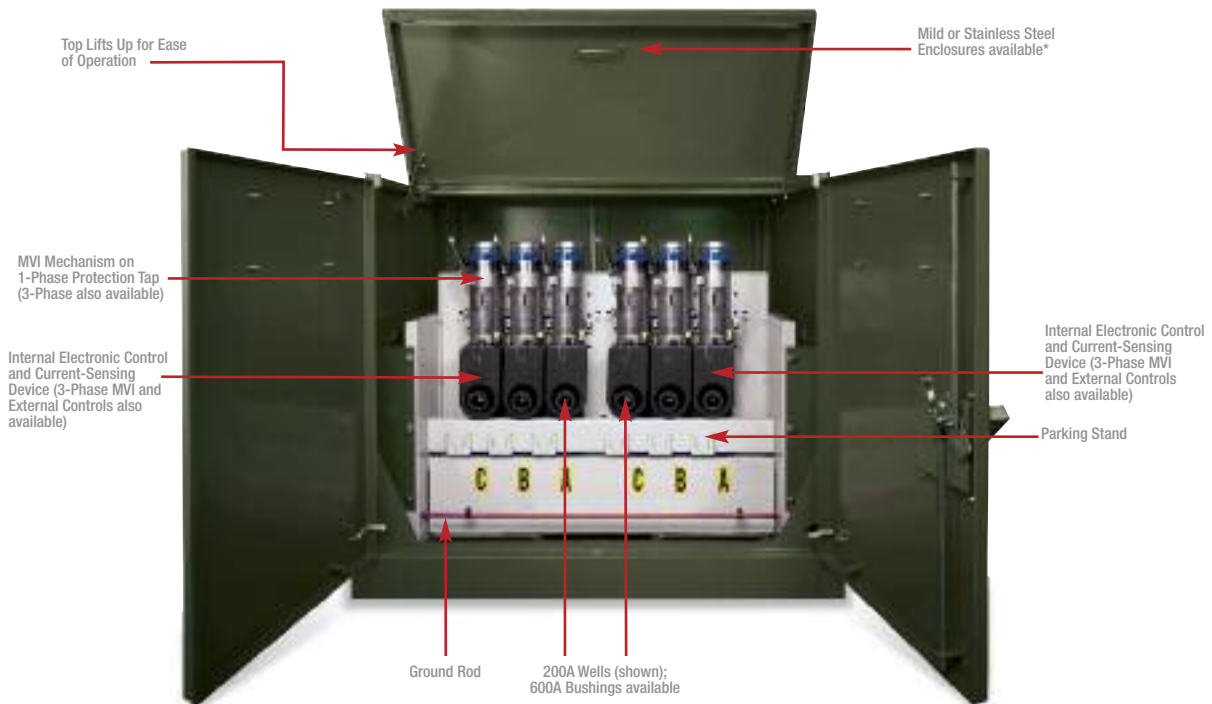

* Also available with a fiberglass enclosure.

Underground Distribution Switchgear

Multi-Way Switchgear and Transfer Packages

The following diagram shows how to construct a catalogue number for Multi-Way Switchgear or Transfer Packages. Catalogue number are shown on page A61 for the most common configurations.

EXAMPLE: The catalogue number for an auto-transfer package for padmount installation on a 3-phase, 27 kV system, with two MVI protected taps, 600 A terminals and standard mild steel enclosure is **ATD324-AAPP-6666**.

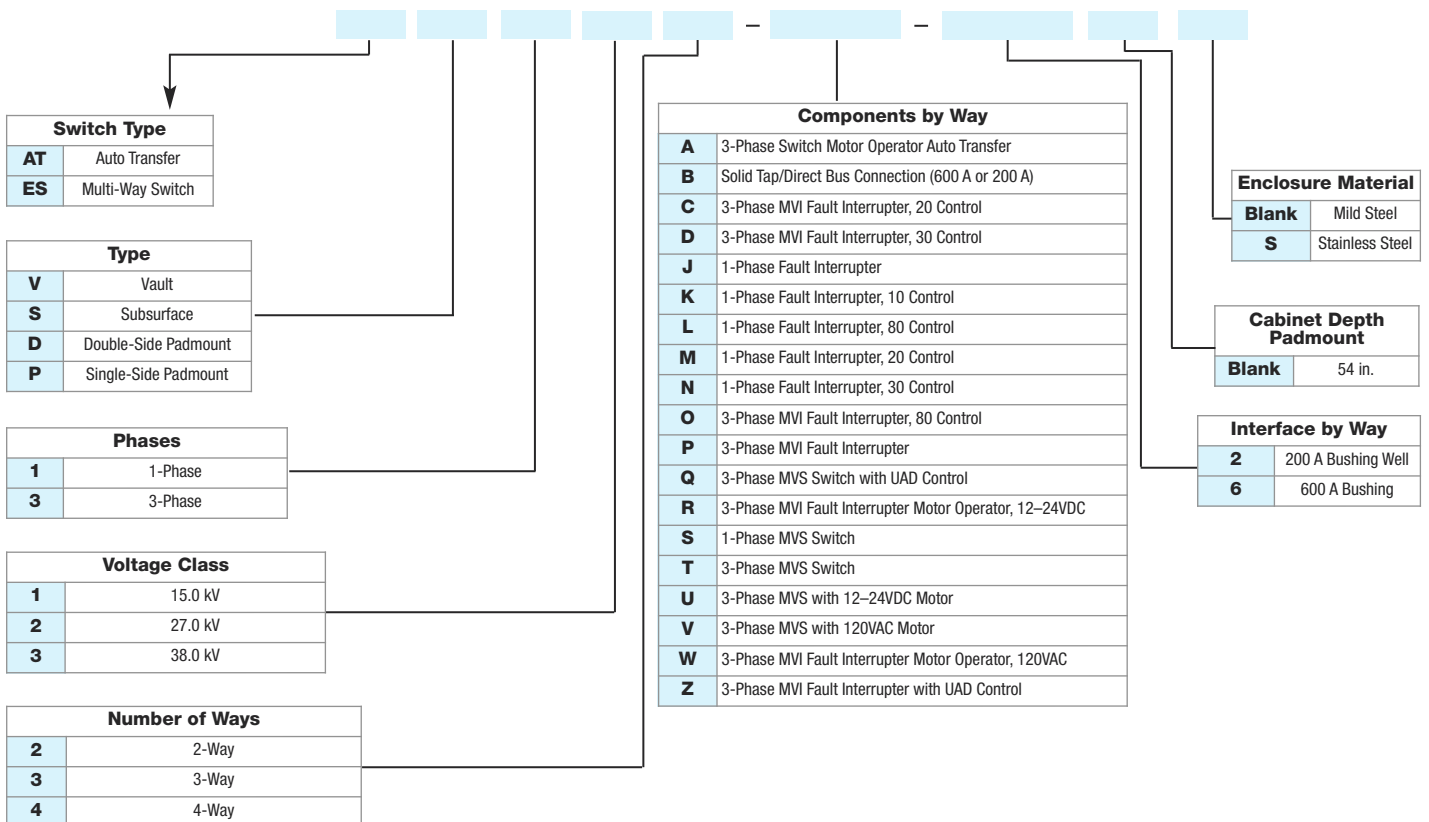

Example: ATD324-AAPP-6666

Custom padmount enclosure dimensions are available.
 Parking stands are standard on padmount units.
 Consult your Regional Sales Office on multi-way configurations that include 38kV MVIs.
 3-Phase MVS and MVI are motor-ready.
 Auto-transfer ways 1 and 2 are always "A."

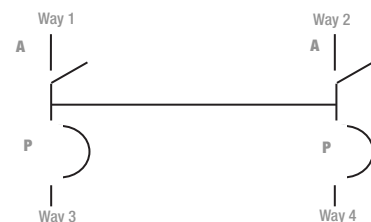

Underground Distribution Switchgear

Multi-Way Switchgear and Transfer Packages

Switching and Sectionalizing Switchgear

Cat. No.	Description	Width in. (mm)	Height in. (mm)	Depth in. (mm)	Weight lb. (kg)	Diagram
Vault						
ESV313-TTT-XXX	15kV 3-Way 3-Phase Switch	48 (1,219)	36 (914)	22 (559)	750 (340)	
ESV323-TTT-XXX	27kV 3-Way 3-Phase Switch	48 (1,219)	36 (914)	22 (559)	750 (340)	
ESV333-TTT-XXX	38kV 3-Way 3-Phase Switch	48 (1,219)	36 (914)	22 (559)	750 (340)	
ESV314-TTTT-XXXX	15kV 4-Way 3-Phase Switch	48 (1,219)	36 (914)	22 (559)	880 (399)	
ESV324-TTTT-XXXX	27kV 4-Way 3-Phase Switch	48 (1,219)	36 (914)	22 (559)	880 (399)	
ESV334-TTTT-XXXX	38kV 4-Way 3-Phase Switch	48 (1,219)	36 (914)	22 (559)	880 (399)	
Padmount						
PMVS1-21-15-XX	15kV 2-Way 3-Phase Switch	36 (914)	30 (762)	30 (762)	310 (141)	
PMVS1-21-27-XX	27kV 2-Way 3-Phase Switch	36 (914)	30 (762)	30 (762)	310 (141)	
PMVS1-21-38-XX	38kV 2-Way 3-Phase Switch	36 (914)	30 (762)	30 (762)	310 (141)	
ESD312-T-XX	15kV 2-Way 3-Phase Switch	36 (914)	48 (1,219)	42 (1,067)	680 (308)	
ESD322-T-XX	27kV 2-Way 3-Phase Switch	36 (914)	48 (1,219)	42 (1,067)	680 (308)	
ESD332-T-XX	38kV 2-Way 3-Phase Switch	36 (914)	48 (1,219)	42 (1,067)	680 (308)	
ESD313-TTT-XXX	15kV 3-Way 3-Phase Switch	54 (1,317)	48 (1,219)	54 (1,317)	1,250 (567)	
ESD323-TTT-XXX	27kV 3-Way 3-Phase Switch	54 (1,317)	48 (1,219)	54 (1,317)	1,250 (567)	
ESD333-TTT-XXX	38kV 3-Way 3-Phase Switch	54 (1,317)	48 (1,219)	54 (1,317)	1,250 (567)	
ESD314-TTTT-XXXX	15kV 4-Way 3-Phase Switch	54 (1,317)	48 (1,219)	54 (1,317)	1,380 (626)	
ESD324-TTTT-XXXX	27kV 4-Way 3-Phase Switch	54 (1,317)	48 (1,219)	54 (1,317)	1,380 (626)	
ESD334-TTTT-XXXX	38kV 4-Way 3-Phase Switch	54 (1,317)	48 (1,219)	54 (1,317)	1,380 (626)	

X = 6 for 600A or 2 for 200A. Other configurations are available. Consult your local representative for configurations not shown here.

Single-Side Padmount ESP313-BJB-626

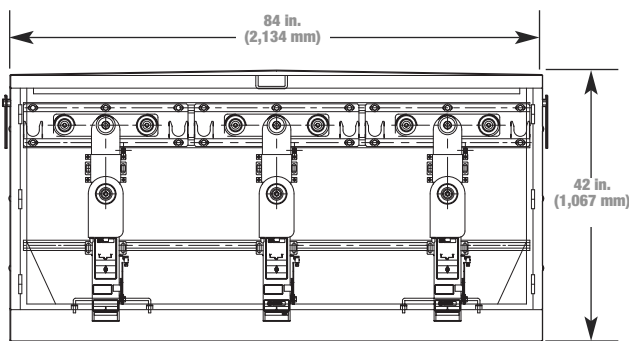

Double-Side Padmount ESD3X4-IIPP-6622-S

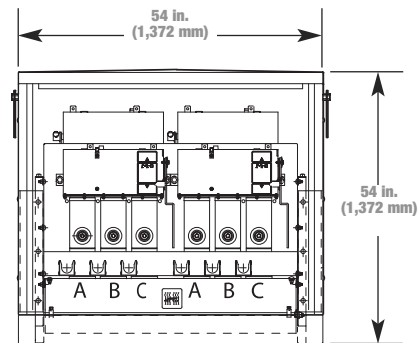

Subsurface ESS3X2-TT-66

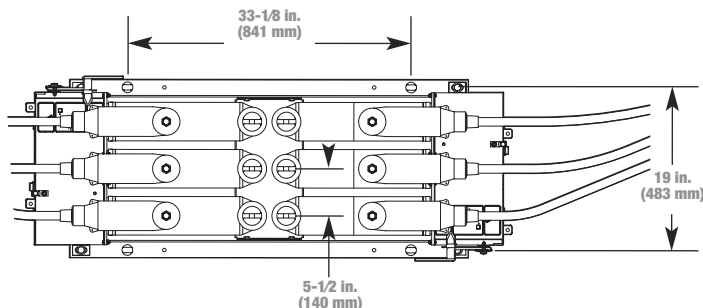

Vault ESV3X4-TTTT-2222

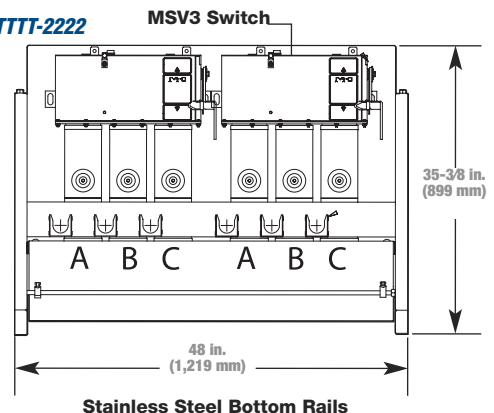

Underground Distribution Switchgear

Multi-Way Switchgear and Transfer Packages

Overcurrent Protection Switchgear

Cat. No.	Description	Width in. (mm)	Height in. (mm)	Depth in. (mm)	Weight lb. (kg)	Diagram
Vault						
ESV313-TPP-XXX	15 kV 3-Way 3-Phase (1) Source Switch, (2) Vacuum Interrupter Taps	40 (1,016)	48 (1,219)	22 (559)	660 (299)	
ESV323-TPP-XXX	27 kV 3-Way 3-Phase (1) Source Switch, (2) Vacuum Interrupter Taps					
ESV313-TTP-XXX	15 kV 3-Way 3-Phase (2) Source Switches, (1) Vacuum Interrupter Tap					
ESV323-TTP-XXX	27 kV 3-Way 3-Phase (2) Source Switches, (1) Vacuum Interrupter Tap					
ESV314-TPPP-XXXX	15 kV 4-Way 3-Phase (1) Source Switch, (3) Vacuum Interrupter Taps				880 (399)	
ESV324-TPPP-XXXX	27 kV 4-Way 3-Phase (1) Source Switch, (3) Vacuum Interrupter Taps					
ESV314-TTTP-XXXX	15 kV 4-Way 3-Phase (2) Source Switches, (2) Vacuum Interrupter Taps					
ESV324-TTTP-XXXX	27 kV 4-Way 3-Phase (2) Source Switches, (2) Vacuum Interrupter Taps					
ESV314-TTTP-XXXX	15 kV 4-Way 3-Phase (3) Source Switches, (1) Vacuum Interrupter Tap					
ESV324-TTTP-XXXX	27 kV 4-Way 3-Phase (3) Source Switches, (1) Vacuum Interrupter Tap					
Padmount						
PMVI1-21-15-XX	15 kV 2-Way 1-Phase Interrupter	36 (914)	30 (762)	30 (762)	310 (141)	
PMVI1-21-27-XX	27 kV 2-Way 1-Phase Interrupter					
PMVI1-21-38-XX	38 kV 2-Way 1-Phase Interrupter					
PMVI1-21-15-XX-3YY	15 kV 2-Way 3-Phase Interrupter 1-Phase Trip Selectable Ext. Control	48 (1,219)	42 (1,067)	30 (762)	680 (308)	
PMVI1-21-27-XX-3YY	27 kV 2-Way 3-Phase Interrupter 1-Phase Trip Selectable Ext. Control					
PMVI1-21-38-XX-3YY	38 kV 2-Way 3-Phase Interrupter 1-Phase Trip Selectable Ext. Control					
ESD312-P-XX	15 kV 2-Way 3-Phase (1) Vacuum Interrupter Tap	36 (914)	48 (1,219)	42 (1,067)	680 (308)	
ESD322-P-XX	27 kV 2-Way 3-Phase (1) Vacuum Interrupter Tap					
ESD332-P-XX	38 kV 2-Way 3-Phase (1) Vacuum Interrupter Tap					
ESD313-TPP-XXX	15 kV 3-Way 3-Phase (1) Source Switch, (2) Vacuum Interrupter Taps	54 (1,372)	48 (1,219)	54 (1,372)	1,160 (526)	
ESD323-TPP-XXX	27 kV 3-Way 3-Phase (1) Source Switch, (2) Vacuum Interrupter Taps					
ESD333-TPP-XXX	38 kV 3-Way 3-Phase (1) Source Switch, (2) Vacuum Interrupter Taps	72 (1,829)	54 (1,372)	72 (1,829)	1,500 (680)	
ESD313-TTP-XXX	15 kV 3-Way 3-Phase (2) Source Switches, (1) Vacuum Interrupter Tap	54 (1,372)	48 (1,219)	54 (1,372)	1,160 (526)	
ESD323-TTP-XXX	27 kV 3-Way 3-Phase (2) Source Switches, (1) Vacuum Interrupter Tap					
ESD333-TTP-XXX	38 kV 3-Way 3-Phase (2) Source Switches, (1) Vacuum Interrupter Tap	72 (1,829)	54 (1,372)	72 (1,829)	1,500 (680)	
ESD314-TPPP-XXXX	15 kV 4-Way 3-Phase (1) Source Switch, (3) Vacuum Interrupter Taps	54 (1,372)	48 (1,219)	54 (1,372)	1,380 (626)	
ESD324-TPPP-XXXX	27 kV 4-Way 3-Phase (1) Source Switch, (3) Vacuum Interrupter Taps					
ESD334-TPPP-XXXX	38 kV 4-Way 3-Phase (1) Source Switch, (3) Vacuum Interrupter Taps	72 (1,829)	54 (1,372)	72 (1,829)	1,500 (680)	
ESD314-TTTP-XXXX	15 kV 4-Way 3-Phase (2) Source Switches, (2) Vacuum Interrupter Taps	54 (1,372)	48 (1,219)	54 (1,372)	1,380 (626)	
ESD324-TTTP-XXXX	27 kV 4-Way 3-Phase (2) Source Switches, (2) Vacuum Interrupter Taps					
ESD334-TTTP-XXXX	38 kV 4-Way 3-Phase (2) Source Switches, (2) Vacuum Interrupter Taps	72 (1,829)	54 (1,372)	72 (1,829)	1,500 (680)	
ESD314-TTTP-XXXX	15 kV 4-Way 3-Phase (3) Source Switches, (1) Vacuum Interrupter Tap	54 (1,372)	48 (1,219)	54 (1,372)	1,380 (626)	
ESD324-TTTP-XXXX	27 kV 4-Way 3-Phase (3) Source Switches, (1) Vacuum Interrupter Tap					
ESD334-TTTP-XXXX	38 kV 4-Way 3-Phase (3) Source Switches, (1) Vacuum Interrupter Tap	72 (1,829)	54 (1,372)	72 (1,829)	1,500 (680)	

X = 6 for 600 A or 2 for 200 A.
 YY = 10, 20, 30, 80 for different electronic controls.
 Consult your Regional Sales Office on 38 kV multi-way configurations.

Molded Fuse Products

Fused Elbows

The fastest, most cost-effective way to improve a distribution system's reliability

Replace existing 200 A tap elbows with Elastimold® Fused Elbows to protect light-duty underground distribution systems, including sub-loops, radial taps, junctions, transformers and other equipment.

Elastimold® Fused Elbows provide full-range current-limiting fusing with 50 kA interrupting capability. They are rated for 5 kV ungrounded to 28 kV grounded Wye. Plus they provide 15/25 kV hotstick-operable, loadbreak elbow switching.

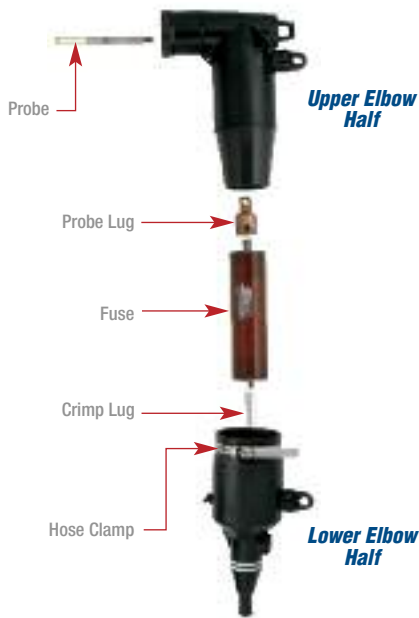

Combined Full-Range Current-Limiting Fusing 15/25 kV Hotstick-Operable, Loadbreak Elbow Switching Quickly improve the distribution system's reliability without the expense of adding a separate piece of switchgear or replacing existing sectionalizing cabinets.

High Fault Close Rating Current-limiting fuses improve the fault close rating of the elbow (10 kA) to that of the fuse, thereby reducing the risk of component damage or personnel injury.

EPDM Molded Rubber Deadfront Construction Elbows are fully sealed and submersible, and they insulate, shield and eliminate exposed live parts.

Two-Piece Housing Enables easy fuse replacement.

Application Information

- Construction: Submersible, non-venting, deadfront, corrosion resistant
- Ambient Temperature Range: -30°C to 65°C

Certified Tests

Elastimold® Fused Elbows have been designed and tested per applicable portions of IEEE, ANSI and other industry standards, including:

- ANSI C37.40** Standard for Current-Limiting Fuse Service Conditions
- ANSI C37.41** Standard for Current-Limiting Fuse Design and Testing
- ANSI C37.47** Standard for Current-Limiting Fuse Ratings and Specifications
- IEEE 386** Standard for Separable Connectors

Ratings

System Voltage Class (kV)	15	25*	25/28*
Nominal Fuse Voltage (kV)	8.3	15.5	17.2
Rated Maximum Fuse Voltage (kV)	8.8/10	15.5	17.2
Frequency (Hz)	50/60	50/60	50/60
BIL Impulse Withstand (kV)	95	125	140
One-Minute AC Withstand (kV)	34	40	45
Fifteen-Minute DC Withstand (kV)	53	78	78
Corona Extinction (kV)	11	19	21.5
Symmetrical Interrupting Capability (Amp)	50,000	50,000	50,000
Current Rating (Amp)	3-80	6-20	3-45

* The 15.5 kV L-G rated fuse requires 75% grounded load to be applied on a 25 kV system. The 17.2 kV L-G rated fuse requires at least 75% grounded load to be applied on a 28 kV system.

Fuses are only suitable for the system voltage class shown if the recovery voltage across the fuse will not exceed its rated maximum voltage. For three-phase applications, this generally requires that protected transformers be gndY-gndY and have at least 50% grounded load. Fuse replacement requires the elbow to be de-energized.

Molded Fuse Products

Fused Elbows

Electrical Characteristics of Elastimold® EFX-E Elbow Fuses

System Voltage Class (kV)	Nominal Fuse Voltage Rating (kV)	Current Rating (A)	Cat. No.	Rated Max. Voltage (kV)	Maximum Continuous Current (2) (6)			Peak Arc Minimum (kV)	Total I2t Melt I2t (A ² -Sec)	Maximum (A ² -Sec) (3) (4)
					25°C	40°C	65°C			
15	8.3	3	EFX083003-E	10.0	4.3	4.2	3.9	30	100	350
		6	EFX083006-E		9.5	9.0	8.5	32	620	2,7
		8	EFX083008-E		11.5	11.0	10.5	28	800	4
		10	EFX083010-E		14.0	13.5	13.0	28	800	4
		12	EFX083012-E		19.0	18.5	17.5	26	920	8
		18	EFX083018-E		21.0	20	19.0	26	1,31	9,5
		20	EFX083020-E		26.0	25	24.0	26	1,62	11
		25	EFX083025-E		34.0	33.0	31.0	26	3,66	22
		30	EFX083030-E		37.5	36.5	34.5	26	5,25	30
		40	EFX083040-E		43.0	42.0	40.0	26	8,7	50
		45	EFX083045-E	49.0	47.0	45.0	26	12,8	70	
		65	EFX083065-E	70.0	68.0	64.5	23	34	200	
		80	EFX083080-E	80.0	77.5	73.5	22	51,2	280	
		25	15.5	6	EFX155006-E	15.5	8.5	8.0	7.7	52
8	EFX155008-E			10.5	10.0		9.5	40	800	4,3
10	EFX155010-E			13.0	12.5		12.0	40	800	4,3
12	EFX155012-E			16.0	15.5		15.0	38	920	8
18	EFX155018-E			20.0	19.5		18.5	38	1,62	13
20	EFX155020-E			23.5	22.5		21.5	38	2,2	16,5
25/28	17.2	3	EFX172003-E	17.2	4.3	4.2	3.9	51	100	510
		6	EFX172006-E		9.5	9.0	8.5	54	620	3,25
		8	EFX172008-E		11.5	11.0	10.5	46	800	4,6
		10	EFX172010-E		14.0	13.5	13.0	46	800	4,6
		12	EFX172012-E		18.0	17.5	16.5	43	920	8,5
		18	EFX172018-E		20.0	19.5	18.5	45	1,31	10
		20	EFX172020-E		24.0	23.0	22.0	45	1,62	12,5
		25	EFX172025-E		31.5	30.5	29.0	45	3,66	27,5
		30	EFX172030-E		35.5	34.5	32.5	45	5,25	37,5
		40	EFX172040-E		41.0	40.0	38.0	45	8,7	62,5
		45	EFX172045-E		46.0	45.0	42.5	45	12,8	87,5

1. Designs have a 50,000 A RMS Symmetrical Rating (except 3 A, 17.2 kV — which was tested at 44 kA maximum).
2. Fuses have a Rated Maximum Application Temperature (RMAT) of 65° C. RMAT is the maximum temperature of the air, in contact with the elbow housing, at which fuses have been shown to be suitable for use.
3. Tabulated Maximum Total I2t values are for currents of 50,000 A at the nominal voltage of the fuse. Values for 8.3kV fuses at 10kV are approximately 30% higher. Values for 17.2 kV fuses at 15.5 kV are approximately 20% lower.
4. Maximum total I2t values are reduced for currents below 50,000A. For example, at 10,000A, maximum total I2t values are approximately 15% less than the published values.
5. Peak arc voltages listed are for 50,000A currents at the rated maximum voltage listed. Reduced currents and voltages will reduce the peak arc voltage. For more information, contact your T&B Regional Sales Office.
6. Maximum continuous currents at ambient temperatures other than those listed may be determined by derating the fuses by 0.2% per degree C over 25°C. For example: At 40°C the derating would be 15 x 0.2 = 3%, making the maximum continuous current of a 17.2kV, 25A fuse 31.5 x 0.97 = 30.5 A.
7. Time-current characteristic curves are published at 25°C. Reduction in the long time melting current of the fuses (approximately one hour and longer) due to higher ambient temperatures is the same as described above for "maximum continuous currents."

Molded Fuse Products

Fused Elbows

Recommended Elastimold® EFX-E Elbow Fuse at 40°C Ambient Temperature

Recommended Fuse Current Ratings (Amperes)																	
Fuse Voltage	8.3 kV										15.5 kV (17.2 kV)						
1-Phase Transformer kVA	Transformer 1-Phase Voltage Rating (kV), Phase to Ground																
	2.4		4.16		4.8		7.2		7.62		12		14.4		16		
	A	B	A	B	A	B	A	B	A	B	A	B	A	B	A	B	
10	—	6	—	6a	—	3	—	3	—	3	—	6a	—	6a	—	(3a)	
15	—	10	—	6	—	6a	—	3	—	3	—	6a	—	6a	—	(3a)	
25	12	20	—	8	—	8	—	6	—	6	—	6a	—	6a	—	-3	
37.5	20	25	—	12	—	12	—	8	—	6	—	6	—	6a	—	(6a)	
50	25	40	18	20	12	20	10	12	—	10	—	6	—	6	—	(6a)	
75	45	65	20	30	20	25	12	20	12	18	—	10	—	8	—	-8	
100	65	80	30	45	25	40	18	25	18	25	12	18	10	12	—	-10	
167	—	—	65	80	45	65	25	45	25	45	18	-25	18	20	-12	-20	
250	—	—	80	—	80	—	45	65	45	65	-25	-45	20	-30	-20	-30	
333	—	—	—	—	—	—	65	—	80	—	-40	—	-30	-45	-25	-45	
500	—	—	—	—	—	—	—	—	—	—	—	—	-45	—	-45	—	

Recommended Elastimold® EFX-E Elbow Fuse at 40°C Ambient Temperature

Recommended Fuse Current Ratings (Amperes)																		
Fuse Voltage	8.3 kV												15.5 kV (17.2 kV)					
1-Phase Transformer kVA	Transformer 1-Phase Voltage Rating (kV), Phase to Ground																	
	2.4		4.16		4.8		7.2-7.96		8.32		12.47		13.2-14.4		20.8		22.9-24.9	
	A	B	A	B	A	B	A	B	A	B	A	B	A	B	A	B	A	B
15	—	6	—	3	—	3	—	3 ^a	—	3 ^a	—	6 ^a	—	6 ^a	—	6 ^a	—	(3 ^a)
22.5	—	8	—	6 ^a	—	6 ^a	—	3	—	3	—	6 ^a	—	6 ^a	—	6 ^a	—	(3 ^a)
30	10	12	—	6	—	6	—	6 ^a	—	3	—	6 ^a	—	6 ^a	—	6 ^a	—	(3 ^a)
45	12	20	—	10	—	8	—	6	—	6 ^a	—	6 ^a	—	6 ^a	—	6 ^a	—	(3 ^a)
75	20	30	12	20	—	12	—	8	—	8	—	6	—	6	—	6 ^a	—	-3
100	30	45	18	25	18	20	—	12	—	10	—	8	—	8	—	6 ^a	—	(6 ^a)
112.5	40	65	20	25	18	25	—	12	—	12	—	8	—	8	—	6	—	(6 ^a)
150	45	80	25	40	20	30	18	20	12	20	10	12	10	12	—	6	—	-6
200	65	80	40	65	30	45	20	25	18	25	12	18	12	18	8	10	—	-8
225	80	—	45	65	40	65	20	30	20	25	12	20	12	18	8	10	—	-10
300	—	—	65	80	45	80	30	45	25	40	18	25	18	25	12	18	—	-12
500	—	—	—	—	80	—	65	80	45	80	30	45	30	45	18	-25	-18	-25
750	—	—	—	—	—	—	80	—	80	—	45	65	45	—	-25	-45	-25	-40
1	—	—	—	—	—	—	—	—	—	—	80	—	—	—	-40	—	-40	—

1. Column A = 140–200% of transformer rating and Column B = 200–300% of transformer rating.
 2. Ratings in parenthesis are 17.2 kV fuses.
 3. 8.3 kV, 3–45 A fuses and 15.5 kV, 6–20A fuses are used in the small (size 1) elbow housing; 8.3 kV, 65–80 A fuses and 17.2 kV, 3–45 A fuses are used in the large (size 3) elbow fuse housing.
 4. Recommended fuses meet inrush criteria of 12 times transformer full-load current for 0.1 second and 25 times transformer full-load current for 0.01 second.
 Fuses also meet cold-load pickup criteria of 6 times transformer full-load current for 1 second and 3 times transformer full-load current for 10 seconds.
 a. Fuse allows greater than 300% of transformer rating.

Molded Fuse Products

Full-Range Molded Current-Limiting Fuses

The following diagram shows how to construct a catalogue number for Fuse Housings and Full-Range Current-Limiting Fuses.

Indicates field that must be filled in to complete order.

F L R

Fuse Test Port

A	Two Direct Test Ports
Blank	Two Capacitive Test Points

Nominal Fuse Voltage Rating

168	8.3 kV
274	15.5 kV
274	17.2 kV

Housing

1	Small
3	Large**

Cable Insulation Diameter (in.)

A	0.575 in.–0.740 in.	15–19 mm
B	0.635 in.–0.905 in.	16–23 mm
C	0.805 in.–1.060 in.	20–27 mm
D	0.890 in.–1.220 in.	25–31 mm

Conductor Size

180	6	–
190	–	4
200	4	–
210	–	2
220	2	1
230	1	1/0
240	1/0	2/0
250	2/0	3/0
260	3/0	4/0
270	4/0	–

168FLR1

274FLR1

168FLR3 A = 8-7/8 in. (225 mm)
274FLR3 A = 9-1/4 in. (235 mm)

1. All dimensions rounded up to the nearest eighth inch.
2. Also available with direct test port.
3. Dimensions with Direct Test Port units are 10-1/4 in. (260 mm) or 10-5/8 in. (270 mm).
4. 168FLR3 uses a large housing with a 15 kV, 200 A elbow interface.

* Small Housing is used with 8.3kV (3–45A) and 15.5kV (6–20A) rated fuses.
** Large Housing is used with 8.3kV (65A and 80A) and 17.2kV (3–45A) rated fuses.

Indicates field that must be filled in to complete order.

8.3 kV (3–45 A)/15.5 kV (6–20 A) Fuse

8.3 kV (65–80 A)/17.2 kV (3–45 A) Fuse

All dimensions rounded up to the nearest eighth inch.

E F X **E**

Voltage Rating

083	8.3 kV
155	15.5 kV
172	17.2 kV

Amperage Rating

003	8.3/17.2 kV	3 A
006	8.3/15.5/17.2 kV	6 A
008	8.3/15.5/17.2 kV	8 A
010	8.3/15.5/17.2 kV	10 A
012	8.3/15.5/17.2 kV	12 A
018	8.3/15.5/17.2 kV	18 A
020	8.3/15.5/17.2 kV	20 A
025	8.3/17.2 kV	25 A
030	8.3/17.2 kV	30 A
040	8.3/17.2 kV	40 A
045	8.3/17.2 kV	45 A
065	8.3 kV	65 A
080	8.3 kV	80 A

Molded Fuse Products

Full-Range Molded Current-Limiting Fuses

Application Information

Construction: Submersible, non-venting, deadfront, corrosion resistant
 Ambient Temperature Range:

- -30°C to 65°C for 6–50 A fuses;
- -30°C to 40°C for >50 A fuses.

Certified Tests

Elastimold® Molded Current-Limiting Fuses have been designed and tested per applicable portions of IEEE, ANSI, NEMA and other industry standards, including:

ANSI C37.40 Standard for Current-Limiting Fuse Service Conditions

ANSI C37.41 Standard for Current-Limiting Fuse Design and Testing

ANSI C37.47 Standard for Current-Limiting Fuse Ratings and Specifications

ANSI/IEEE 386 Standard for Separable Connectors and Bushing Interfaces

Ratings

System Voltage Class (kV)	5	15	25/28*	35
Rated Maximum Fuse Voltage (kV)	5.5	8.3/10**	15.5/17.2**	23
Frequency (Hz)	50/60	50/60	50/60	50/60
BIL Impulse Withstand (kV)	60	95	125/140	150
One-Minute AC Withstand (kV)	34	34	40–45	50
Fifteen-Minute DC Withstand (kV)	53	53	78	103
Corona Extinction (kV)	11	11	19/21.5	26
Symmetrical Interrupting Capability (A)	50	50	50	50
Current Rating (A)	80–180	10–115	10–100	10–50

* 15.5 kV L-G rated fuses require 75 % grounded load to be applied on a 25 kV system.
 ** 17.2 kV L-G rated fuses require at least 75 % grounded load to be applied on a 28 kV system.

Fuse replacement requires the MCLF to be de-energized.
 Fuses are only suitable for the system voltage class shown if the recovery voltage across the fuse will not exceed its rated maximum voltage. For three-phase applications, this generally requires that protected transformers be gndY-gndY and have at least 50 % grounded load.

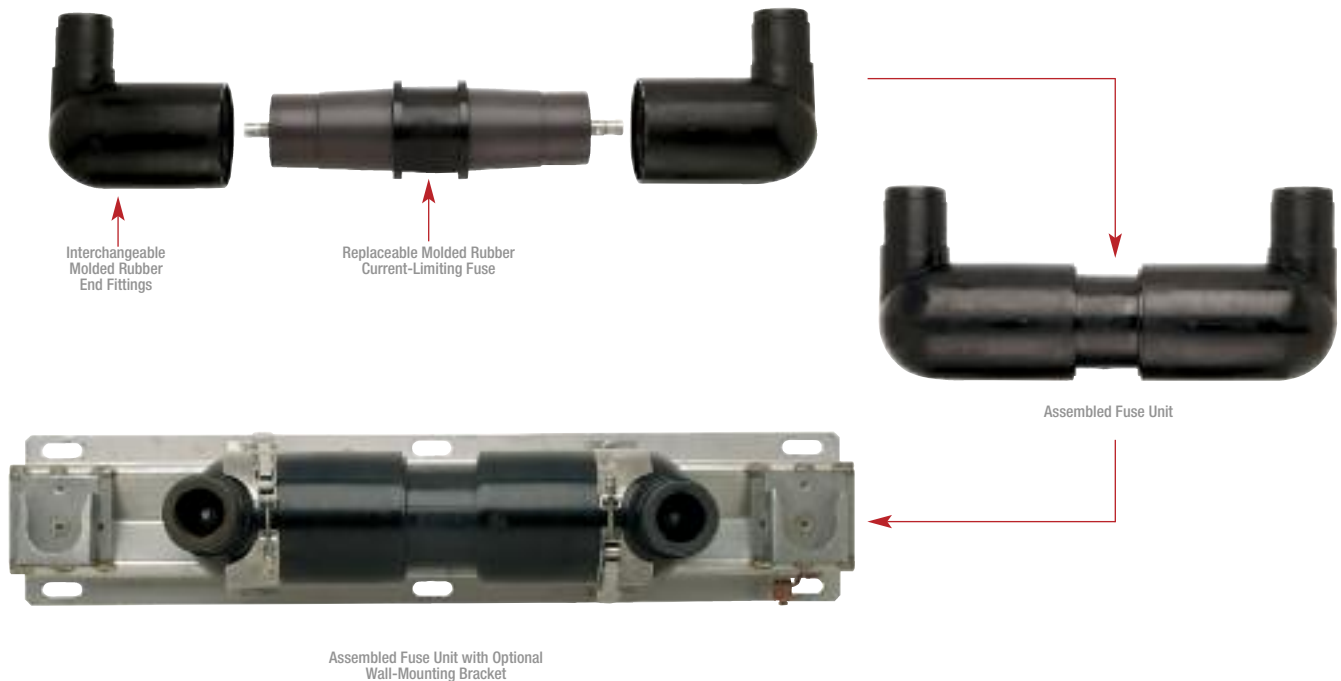

Molded Fuse Products

Full-Range Molded Current-Limiting Fuses

Electrical Characteristics of Encapsulated Fuses Used in MCLF

Nominal Fuse Voltage Rating (kV)	Current Rating (A)	Fuse Catalogue Number	Rated Maximum Voltage (kV)	Maximum Continuous Current (2) (6)		Peak Arc Total I ² t (kV) (5)	Minimum Melt I ² t (A ² -Sec) (3) (4)	Maximum Total I ² t (A ² -Sec) (3) (4)
				25°C	40°C			
5.5	80	M05CLF080	5.5	86	84	15	22,100	110,000
	100	M05CLF100		108	105		56,700	280,000
	125	M05CLF125		137	133		109,200	530,000
	150	M05CLF150		159	154		176,000	860,000
	180	M05CLF180		185	180		259,000	1,270,000
8.3	10	M15CLF010	10.0	14	13	28	800,000	4,000
	20	M15CLF020		23	22	26	1,620	11,000
	30	M15CLF030		35	33	5,250	30,000	
	40	M15CLF040		43	41	8,700	50,000	
	50	M15CLF050	51	47	12,800	70,000		
	65	M15CLF065	73	71	25,200	100,000		
	80	M15CLF080	87	84	47,000	185,000		
	100	M15CLF100	106	103	25	78,300	330,000	
	115	M15CLF115	120	116	115,150	480,000		
	15.5	10	M25CLF010	17.2	14	13	46	800,000
20		M25CLF020	23		22	45	1,620	10,000
30		M25CLF030	35		33	5,250	30,000	
40		M25CLF040	43		41	8,700	50,000	
50		M25CLF050	47	45	12,800	70,000		
65		M25CLF065	68	66	25,200	110,000		
80		M25CLF080	88	84	40	54,400	255,000	
100		M25CLF100	100	100	80,000	380,000		
23.0	10	M35CLF010	23.0	14	13	61	800,000	4,800
	20	M35CLF020		23	22	60	1,620	13,000
	30	M35CLF030		35	33	5,250	38,000	
	40	M35CLF040		41	40	8,700	61,000	
	50	M35CLF050		47	46	12,800	82,000	

1. Designs have a 50,000 A all U/CERMSs Symmetrical Rating.
2. 10–50 A fuses have a Rated Maximum Application Temperature of 65°C, and 65–180 A fuses have a Rated Maximum Application Temperature of 40°C. (RMAT is the maximum temperature of the air in contact with the MCLF housing at which the fuses have been shown suitable for use.)
3. Tabulated Maximum Total I²t values are for currents of 50,000 A at the nominal voltage of the fuse. Fuses that have a Rated Maximum Voltage higher than their Nominal Voltage Rating will have a higher I²t let-through when applied at voltages up to these higher values. For example, Maximum Total I²t values are increased by approximately 30% when 8.3 kV fuses are applied at 10kV and approximately 25% when 15.5kV fuses are used at 17.2 kV.
4. Maximum total I²t values are reduced for currents below 50,000 A. For example, at 10,000 A, I²t values are approximately 15% less than the published values.
5. Peak arc voltages quoted are for 50,000A currents at the rated maximum voltage listed. Reduced currents and voltages will reduce the peak arc voltage. Consult the factory for further information.
6. Maximum continuous currents at higher ambient temperatures may be determined by derating the fuses by 0.2% per degree C over 25° C. For example: At 40°C, the derating would be 15 x 0.2 = 3%, making the maximum continuous current of a 20 A fuse 23.0 x 0.97 = 22 A.

Molded Fuse Products

Full-Range Molded Current-Limiting Fuses

Recommended MCLF at 40°C Ambient Temperature

Fuse Voltage	Recommended Fuse Current Ratings (Amperes)																	
	(5.5 kV) 8.3 kV									15.5 kV						23 kV		
	Transformer 1-Phase Voltage Rating (kV), Phase to Ground																	
	2.4		4.16		4.8		7.2		7.62		12		14.4		16		34.5	
1-Phase Transformer kVA	A	B	A	B	A	B	A	B	A	B	A	B	A	B	A	B	A	B
10	—	10a	—	10a	—	10a	—	10a	—	10a	—	10a	—	10a	—	10a	—	10a
15	—	10	—	10a	—	10a	—	10a	—	10a	—	10a	—	10a	—	10a	—	10a
25	—	20	—	10	—	10	—	10a	—	10a	—	10a	—	10a	—	10a	—	10a
37.5	20	30	—	20	—	20	—	10	—	10	—	10a	—	10a	—	10a	—	10a
50	30	40	20	30	—	20	—	10	—	10	—	10a	—	10a	—	10a	—	10a
75	50	65	30	40	20	30	—	20	—	20	—	10	—	10	—	10	—	10a
100	65	-80	40	50	30	50	20	30	20	30	—	20	—	10	—	10	—	10
167	-100	-150	65	-80	50	65	30	50	30	50	20	30	20	30	—	20	—	20
250	-150	—	(100)	-125	-80	-100	50	65	50	65	30	50	30	40	20	30	20	30
333	-180	—	-125	-180	-100	-150	65	100	65	100	50	65	30	50	30	50	20	40
500	—	—	-180	—	-150	—	115	—	115	—	65	100	65	80	50	—	40	—
750	—	—	—	—	—	—	—	—	—	—	100	—	80	100	—	—	—	—
1	—	—	—	—	—	—	—	—	—	—	—	—	100	—	—	—	—	—

Recommended MCLF at 40°C Ambient Temperature

Fuse Voltage	Recommended Fuse Current Ratings (Amperes)																		
	8.3 kV									15.5 kV (17.2 kV)						23 kV			
	Transformer 1-Phase Voltage Rating (kV), Phase to Ground																		
	2.4		4.16		4.8		7.2-7.96		8.32		12.47		13.2-14.4		20.8		22.9-24.9		34.5
1-Phase Transformer kVA	A	B	A	B	A	B	A	B	A	B	A	B	A	B	A	B	A	B	
15	—	10a	—	10a	—	10a	—	10a	—	10a	—	10a	—	10a	—	10a	—	10a	
22.5	—	10	—	10a	—	10a	—	10a	—	10a	—	10a	—	10a	—	10a	—	10a	
30	—	10	—	10a	—	10a	—	10a	—	10a	—	10a	—	10a	—	10a	—	10a	
45	—	20	—	10	—	10	—	10a	—	10a	—	10a	—	10a	—	10a	—	10a	
75	30	40	—	20	—	20	—	10	—	10	—	10a	—	10a	—	10a	—	10a	
100	40	50	20	30	20	30	—	20	—	10	—	10	—	10	—	10a	—	10a	
112.5	40	65	20	30	20	30	—	20	—	10	—	10	—	10	—	10a	—	10a	
150	50	-80	30	50	30	40	20	30	—	20	—	10	—	10	—	10a	—	10a	
200	65	-100	40	65	40	50	20	30	20	30	—	20	—	20	—	10	—	10a	
225	-80	-125	50	65	40	65	30	40	30	50	—	20	—	20	—	10	—	10a	
300	-100	-150	65	-100	65	-80	40	50	30	50	20	30	20	30	—	20	10	20	
500	-180	—	-100	-150	-100	-125	65	-80	50	80	30	50	30	50	20	30	20	30	
750	—	—	-180	—	-125	-180	-80	-125	80	115	50	80	50	65	30	50	30	40	
1,000	—	—	—	—	-180	—	-125	-180	115	—	65	100	65	100	50	65	40	65	
1,500	—	—	—	—	—	—	-180	—	—	—	100	—	100	—	65	100	65	80	
2,000	—	—	—	—	—	—	—	—	—	—	—	—	—	100	—	80	—	50	

1. Column A = 140–200% of transformer rating and Column B = 200–300% of transformer rating.
 2. Ratings in parentheses are 5.5kV fuses.
 3. Recommended fuses meet inrush criteria of 12 times transformer full-load current for 0.1 second and 25 times transformer full-load current for 0.01 second.
 Fuses also meet cold-load pickup criteria of 6 times transformer full-load current for 1 second and 3 times transformer full-load current for 10 seconds.

a. Fuse allows greater than 300% of transformer rating.

Molded Fuse Products

Full-Range Molded Current-Limiting Fuses

Model 22

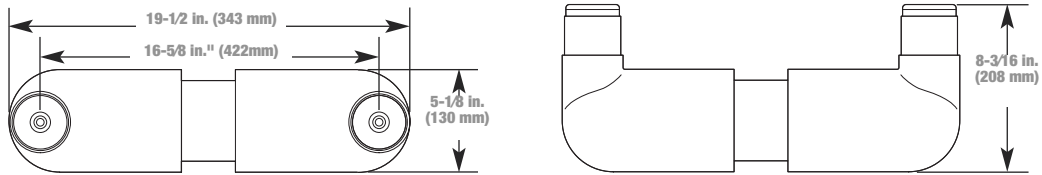

Approx. Weight 30 lb. (13.6 kg)

Model 222

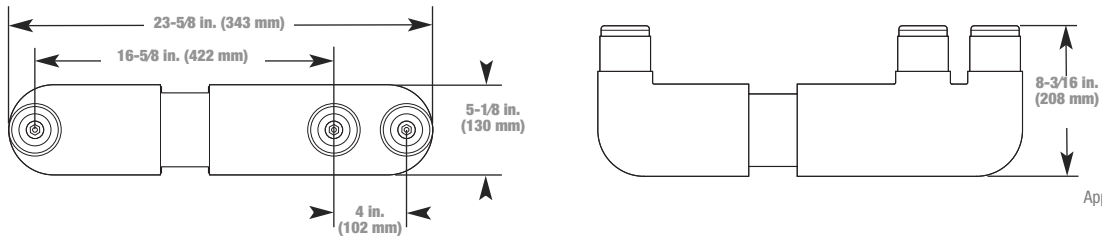

Approx. Weight 35 lb. (15.9 kg)

Model 2222

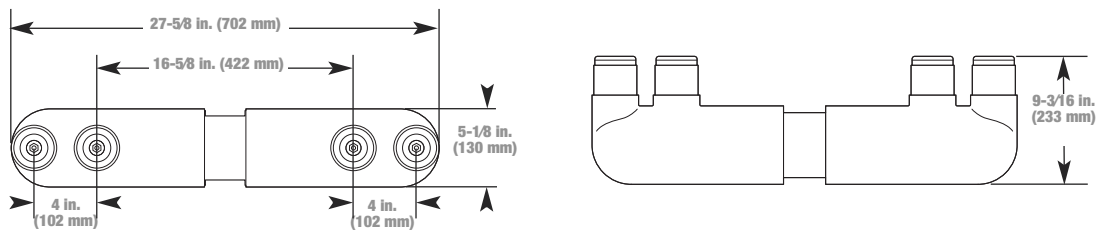

Approx. Weight 30 lb. (13.6 kg)

Model 66

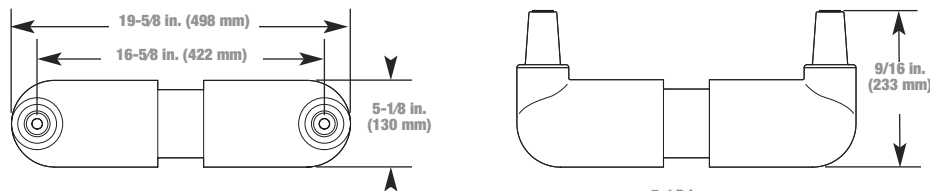

Approx. Weight 40 lb. (18.1 kg)

Model 6E2

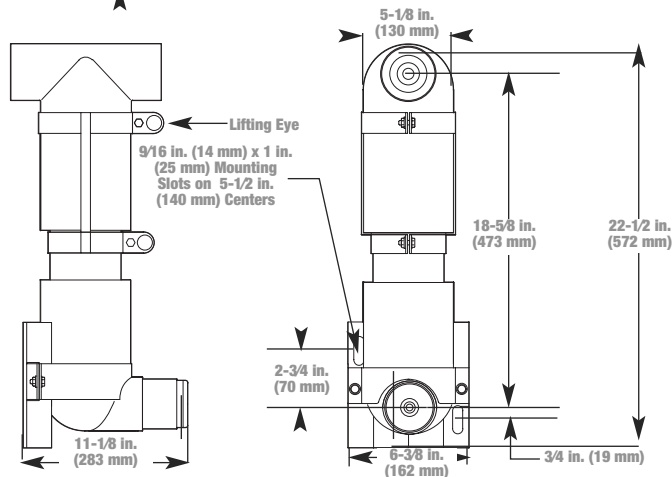

Approx. Weight 30 lb. (13.6 kg)

Molded Fuse Products

Full-Range Molded Current-Limiting Fuses

Model 6E6

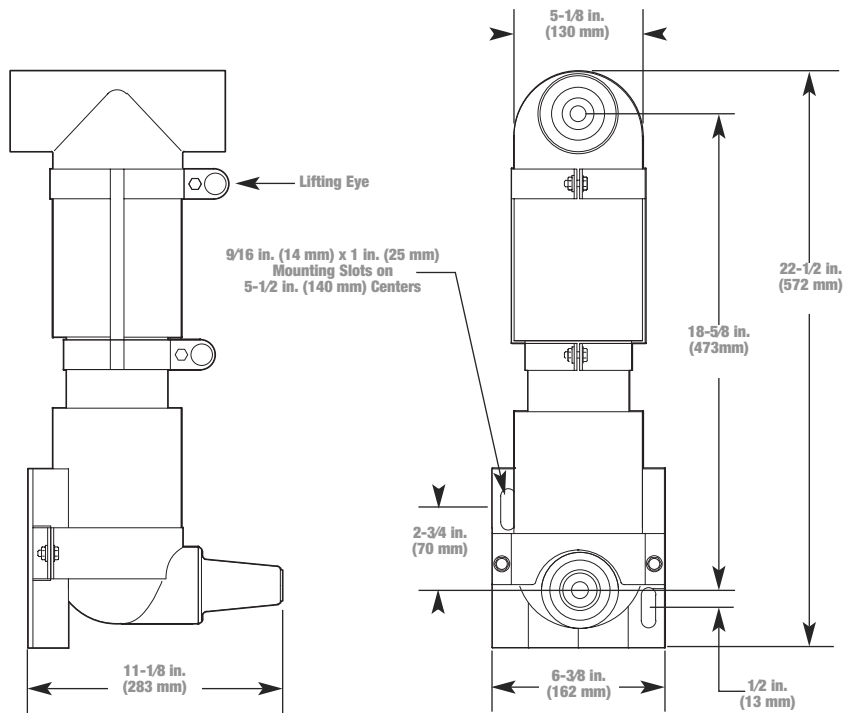

Other models are available such as 26.
Approx. Weight 30 lb. (13.6kg)

The following diagram shows how to construct a catalog number for a Molded Current-Limiting Fuse:

 Indicates field that must be filled in to complete order.

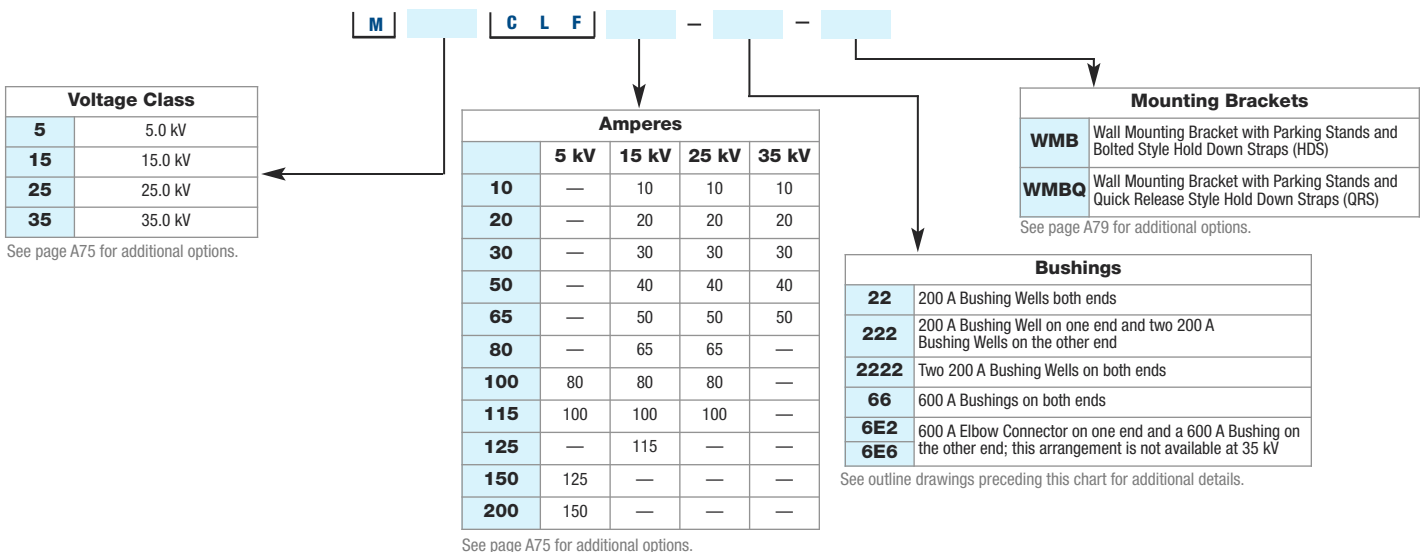

Molded Fuse Products

Full-Range Molded Current-Limiting Fuses

Mounting Options

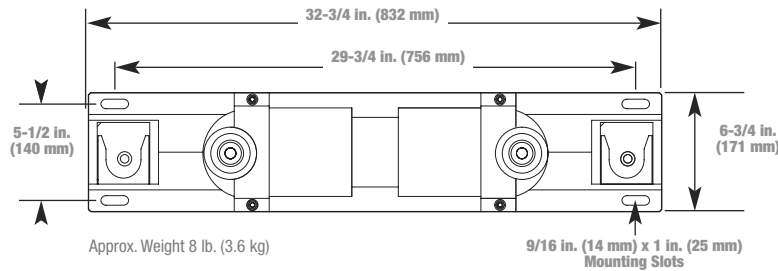

Optional WMB Mounting Bracket with Adjustable Parking Stands for Vertical Mounting and Fuse Hold-Down Straps

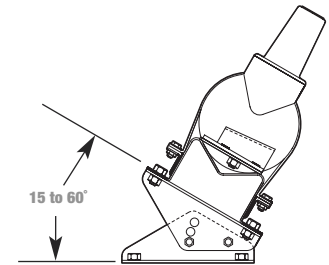

Optional — TMA Universal Tilt Mounting

Optional Fuse Mountings

Option No.	Description
HDS	Bolted-Style Hold-Down Strap (Qty: 1 required per end fitting)
QRS	Quick-Release Style Hold-Down Strap (Qty: 1 required per end fitting)
WMB	Wall-Mounting Bracket with Parking Stands and Bolted-Style Hold-Down Straps
WMBQ	Wall-Mounting Bracket with Parking Stands and Quick-Release Style Hold-Down Straps
SMB	Support Mounting Bracket for use with Models 6E2 or 6E6 end-fitting arrangements includes Bolted-Style Hold-Down Strap
TMA-EM	Tilt Mounting Adapter bolts to bottom of Wall-Mounting Bracket WMB or WMBQ to enable up to 60° angle mounting (Qty: 2 required per installation)

The option number may be added as a suffix to the MCLF catalogue number.

End Fitting Catalogue Numbers

Option No.	Description	System Voltage Class	IEEE 386-1995 Interface Reference
EF2	200 A Bushing Well End Fitting	5, 15, 25, 35	Figure 3
EF22	Double 200 A Bushing Well End Fitting	5, 15, 25, 35	Figure 3
EF6	600 A Bushing End Fitting	5, 15, 25, 35	Figures 11 and 13
EF6E	600 A Elbow Connector End Fitting	5, 15, 25	Figure 11

EF6E is equipped with a standard through-hole spade lug (Type 03700).

Use this table only if end fittings are to be ordered and shipped separately from the fuse. See pages A77-A78 for assembled units.

Assembly/Disassembly Tool

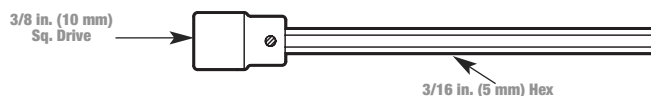

Other Options

Option No.	Description
MCLF-ADT	Hex Wrench for set screw removal and replacement when disassembling end fittings. Supplied as standard with replacement fuses.

Surge Arresters

Metal Oxide Varistor (MOV) Surge Arresters

Fully shielded, fully submersible for convenient energized connection with 200 A loadbreak or deadbreak components up to 35 kV

Voltage surges that exceed the BIL rating of the distribution system components will cause damage to the installed equipment. To protect against these surges, overhead surge arresters are widely used. Their application is understood since overhead lines and equipment are directly affected by voltage surges (e.g. lightning). However, the use of overhead arresters alone will not guarantee proper protection of the insulation in the underground portion of an electrical distribution system. The let through surge from the riser pole arresters into the underground systems could be enough to cause damage to the aging equipment insulation.

Elastimold® MOV Surge Arresters provide high-voltage lightning and switching surge protection of transformers, cable, equipment and other components typically located on underground power distribution systems. Proper placement, voltage selection and coordination with riser pole arresters minimize damaging surge voltages by improving protective margins.

Typical applications include installing an arrester at the end of a radial system or at both ends of an open point on a loop system. Additional arresters can be added at strategic locations upstream from the end point for optimum protection.

Metal Oxide Varistor (MOV) Surge Arresters are available in three styles: Elbow (ESA), Parking Stand (PSA) and Bushing (BSA). The PSA and BSA arresters permit direct connection, eliminating the need for additional accessories. ESA Elbow Arresters are also available with a 200 A deadbreak interface for mating with other deadbreak accessories.

The following page highlights the different installation options using Bushing and Parking Stand Arresters where Elbow Arresters are normally used. Using BSAs and PSAs will contribute to saving space inside transformers and improving operability.

IEEE 386 Interfaces; IEEE C62.11 Provide convenient energized connection with other 200 A loadbreak or deadbreak components.

EPDM Molded Rubber Construction Fully shielded and fully submersible for a variety of applications.

Compact Size Enables installation in your existing cabinetry, saving you money.

Three Styles of Arresters Available Surge arresters fit your application and are easy to install.

Direct Connection on PSA and BSA Versions Eliminates the need for additional accessories, saving even more money.

#4 AWG Ground Lead Tethered to the Jacket Withstands 10,000 A for 10 cycles without fusing. Controls end plug when ejected, preventing uncontrolled trajectory. Maintains the housing shield ground connection after failure.



Ratings

High Current, Short Duration	All MOV Arresters withstand two discharges of 40 kA crest
Low Current, Long Duration	All MOV Arresters withstand 20 surges of 75 A/2,000 microseconds duration
Duty Cycle Test	All MOV Arresters withstand 22 operations of 5 kA crest at 8 x 20 microseconds duration while energized at rated voltage for the initial 20 operations and at maximum continuous operating voltage (MCOV) for the final two operations

Following each of the preceding tests, MOV Arresters demonstrate thermal recovery at MCOV.

Surge Arresters

Installation Options

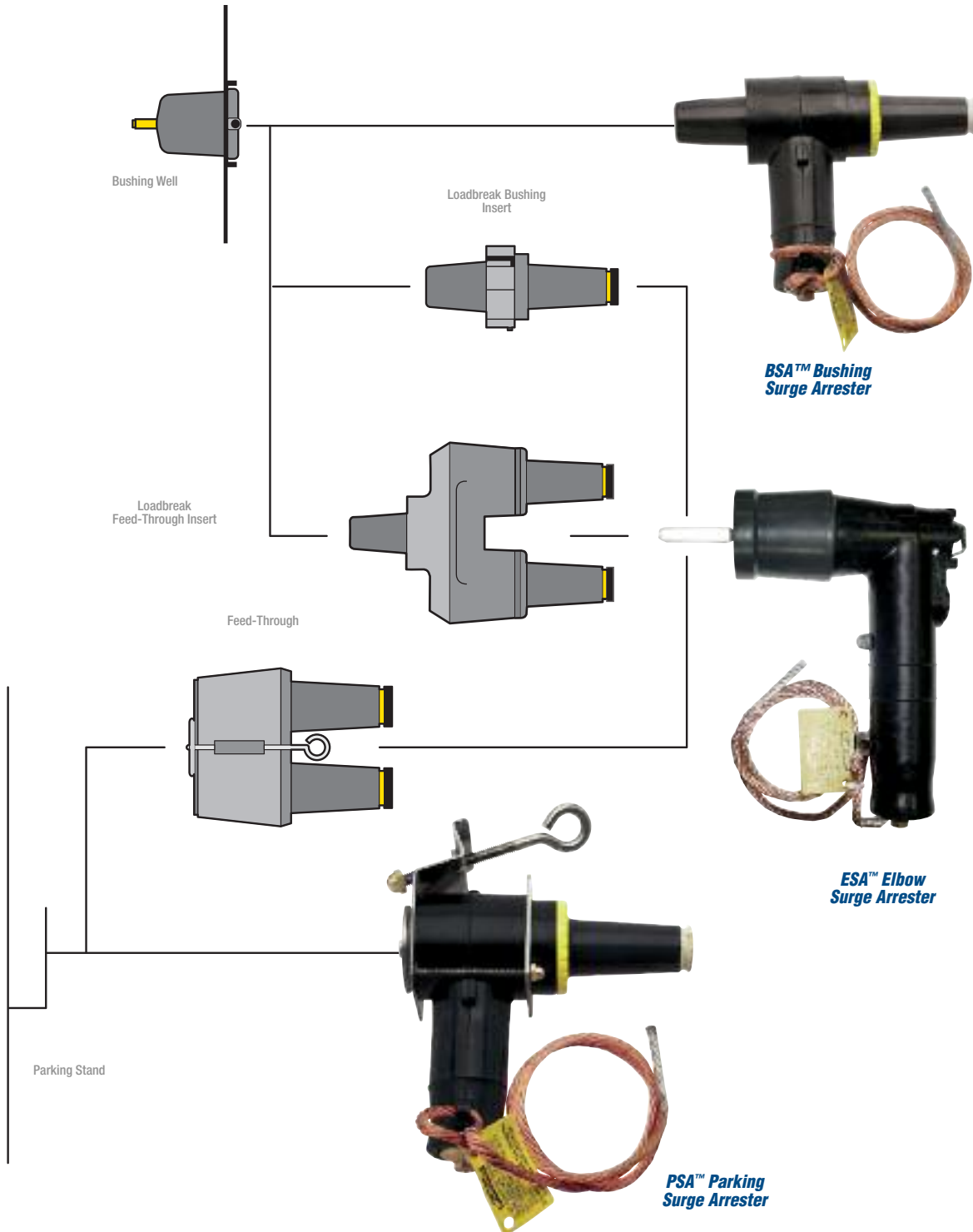

Surge Arresters

Loop-Feed Circuit (Type 2 Transformer)

Two Elbow Arresters and a Feed-Through

This is one approach using elbow arresters only. (One of the elbow arresters could be mounted on the H1A bushing if operating procedures permit.)



Elbow Arrester and Parking Stand Arrester

This approach can reduce overcrowding (by eliminating the feed-through device). This is desirable in a mini-pad transformer.



Bushing Arrester and Parking Stand Arrester*

This approach is best for increasing operability and reducing transformer overcrowding. The bushing arrester enables the source cable to be positioned on H_{1A}, which conforms with some operating practices. A bushing arrester mounted on H_{1A} can be directed downward without interference. Potential interference between an elbow arrester on H_{1B} and a cable parked on P is eliminated. The bushing arrester requires significantly less space than an elbow arrester used with a feed-through insert. Operability is enhanced because the open point can be closed by moving the parked cable to H_{1B} without removing an arrester.

* Transformers must be specified with bushing wells.



Additional Margin of Protection

An additional margin of protection may be gained by adding an arrester at the next transformer upstream on each side of the open point. This application is dependent on the system voltage and condition of the cable.

If an additional arrester is added in the circuit, it can be an elbow arrester in combination with a feed-through insert or it can be a bushing arrester. Use of a bushing arrester will reduce transformer faceplate overcrowding.



Other Configurations

Other configurations are possible, such as specifying a bushing arrester on every transformer. This enables the open point to be quickly and easily moved to any point in the circuit while maintaining the surge protection (without moving all of the portable surge arresters). The externally mounted bushing arrester provides the surge protection benefits without the negative factors of an under-oil arrester.

Surge Arresters

Radial-Feed Circuit (End Point)

Single-Bushing Transformer

To add surge protection to a single-bushing transformer, utilize a bushing arrester or an elbow arrester with a feed-through insert.



Two-Bushing Transformer

To add surge protection to a two-bushing transformer at the end point of a radial-feed circuit, add an elbow arrester to the unoccupied bushing or utilize a bushing arrester.



Conversion of a Radial-Feed Transformer to a Loop-Feed, Open-Point Transformer

To convert a single-bushing transformer to a loop-feed, open-point transformer, add a parking stand arrester and an elbow arrester in combination with a feed-through insert.



Protective Characteristics

Class	MCOV* (kV RMS)	Duty Cycle Rating (kV RMS)	Maximum Discharge Voltage (kV Crest) 8 x 20 Microsecond Currentwave				
			1.5 kA	3 kA	5 kA	10 kA	20 kA
15kV	2.55	3	10.5	11.0	11.5	13.0	14.5
15kV	5.1	6	20.5	21.5	23.0	25.5	30.0
15kV	8.4	10	30.5	32.5	34.5	38.5	43.5
15kV	10.2	12	40.0	42.5	45.0	50.0	56.5
15kV	12.7	15	48.0	51.0	54.0	60.0	68.0
15kV	15.3	18	56.5	60.0	64.0	71.0	80.5
25kV	8.4	10	30.5	32.5	34.5	38.5	43.5
25kV	10.2	12	40.0	42.5	45.0	50.0	56.5
25kV	12.7	15	48.0	51.0	54.0	60.0	68.0
25kV	15.3	18	56.5	60.0	64.0	71.0	80.5
25kV	17.0	21	65.5	69.5	74.0	82.5	93.2
35kV	19.5	24	78.5	83.5	89.0	99.0	112.0
35kV	22.0	27	87.5	93.0	99.0	110.0	124.5
35kV	24.4	30	98.5	101.5	108.0	120.0	136.0

* MCOV = Maximum Continuous Operating Voltage

Surge Arresters

MOV Surge Arresters

To specify and order an MOV Surge Arrester:

- 1) Determine the appropriate Maximum Continuous Operating Voltage (MCOV) for your system voltage using the Arrester Application Table below.
- 2) Specify the appropriate Elastimold® catalogue number from the Selection Chart.

Arrester Application Table

	System Line-to-Line Voltage kVrms		MCOV* kV RMS	
	Nominal	Maximum	Solidly Grounded Neutral Circuits	3-Wire Ungrounded Circuits
	15 kV Class	2.40	2.54	2.55
4.16		4.40	2.55	5.10
4.80		5.08	5.10	5.10
6.90		7.26	5.10	8.40
8.32		8.80	5.10	8.40
12.47		13.20	8.40	15.30
13.20		13.97	8.40	15.30
13.80		14.50	8.40**	15.30
13.80		14.50	10.20	15.30
6.90		7.26	5.10	8.40
8.32		8.80	5.10	8.40
12.47		13.20	8.40	15.30
25 kV Class	13.20	13.97	8.40	15.30
	13.80	14.50	8.40**	15.30
	13.80	14.50	10.20	15.30
	20.78	22.00	12.70	—
	20.78	22.00	15.30**	—
	23.00	24.34	15.30	—
	24.94	26.40	15.30	—
	24.94	26.40	17.00**	—
	28.00	29.80	17.00	—

* MCOV = Maximum Continuous Operating Voltage.
 ** Preferred arrester MCOV for this system voltage.

Selection Chart

Cat. No.	Description	Voltage Class	MCOV kV RMS	Picture
167BSA-3	BSA Bushing Surge Arrester (includes assembly tool) See Notes 1–4	15kV	2.55	
167BSA-6			5.10	
167BSA-10			8.40	
167BSA-12			10.20	
167BSA-15			12.70	
167BSA-18			15.30	
273BSA-10		25kV	8.40	
273BSA-12			10.20	
273BSA-15			12.70	
273BSA-18			15.30	
273BSA-21			17.00	
167ESA-3			ESA Elbow Surge Arrester See Notes 1, 2, 5	
167ESA-6	5.10			
167ESA-10	8.40			
167ESA-12	10.20			
167ESA-15	12.70			
167ESA-18	15.30			
273ESA-10	25kV	8.40		
273ESA-12		10.20		
273ESA-15		12.70		
273ESA-18		15.30		
273ESA-21		17.00		
167PSA-3		PSA Parking Stand Arrester See Notes 1–3		15 kV
167PSA-6	5.10			
167PSA-10	8.40			
167PSA-12	10.20			
167PSA-15	12.70			
167PSA-18	15.30			
273PSA-10	25kV		8.40	
273PSA-12			10.20	
273PSA-15			12.70	
273PSA-18			15.30	
273PSA-21			17.00	

1. Elastimold® PSA and BSA Arresters are equipped with a fully rated 200 A switching and fault-close loadbreak bushing.
2. Elastimold® Arresters use high-strength, silver epoxy-bonded MOV blocks and shunted spring connections for the best circuit connection.
3. A 3/8 in. 4 AWG ground lead is provided with each unit.
4. BSA installed by turning internal hex bolt (accessed through the 200A bushing interface) with a 5/16" hex wrench and bent-wire torque wrench supplied with each unit.
5. For 15 kV and 25 kV class deadbreak system Elbow Arresters, use catalog number 156ESA with the appropriate duty cycle rating.

Surge Arresters

MOV Surge Arresters (cont'd)

To specify and order an MOV Surge Arrester:



- 1) Determine the appropriate Maximum Continuous Operating Voltage (MCOV) for your system voltage using the Arrester Application Table below.
- 2) Specify the appropriate Elastimold® catalogue number from the Selection Chart.

Arrester Application Table

35 kV Class	System Line-to-Line Voltage kVrms		MCOV* kV RMS	
	Nominal	Maximum	Solidly Grounded Neutral Circuits	3-Wire Ungrounded Circuits
	23.00	24.34	—	22.00
	34.50	36.51	22.00**	—
34.50	36.51	24.40	—	

* MCOV = Maximum Continuous Operating Voltage.
 ** Preferred arrester MCOV for this system voltage.

Selection Chart

Cat. No.	Description	Voltage Class	MCOV kV RMS	Picture
375BSA-24	BSA Bushing Surge Arrester See Notes 1–4	35 kV	19.50	
375BSA-27			22.00	
375BSA-30			24.40	
375ESA-24	ESA Elbow Surge Arrester See Notes 2–3		19.50	
375ESA-27			22.00	
375ESA-30			24.40	
375PSA-24	PSA Parking Stand Arrester See Notes 1–3		19.50	
375PSA-27			22.00	
375PSA-30			24.40	

1. Elastimold® PSA and BSA Arresters are equipped with a fully rated 200 A switching and fault-close loadbreak bushing.
2. Elastimold® Arresters use high-strength, silver epoxy-bonded MOV blocks and shunted spring connections for the best circuit connection.
3. A 36 in. 4 AWG ground lead is provided with each unit.
4. BSA installed by turning internal hex bolt (accessed through the 200 A bushing interface) with a 5/16 in. hex wrench and bent-wire torque wrench supplied with each unit.
5. For 15 kV and 25 kV class deadbreak system Elbow Arresters, use catalogue number 156ESA with the appropriate duty cycle rating.

Molded Vacuum Recloser

The Elastimold® Recloser, in either single-phase or three-phase configurations, is fully compatible with SEL® Controls

Smart, Light and Flexible

The Elastimold® Recloser is world-class, by design. It responds to every hardware requirement that utilities want.

Smart – Our recloser is Smart Grid ready with three integral load-side voltage sensors and provision to add source-side voltage sensors, if desired. It was designed to be fully compatible with the industry's No. 1 name in controls, Schweitzer Engineering Laboratories.

Light – The three-phase Elastimold® Recloser weighs 33% less than existing typical units. The simplicity of the mechanism design, and the compactness of the encapsulated components, contribute to making the Elastimold® Recloser easier to move and install.

Flexible – The Elastimold® Recloser is modular, so field upgrades and retrofits are easy and fast. The single phase recloser has a pole rotation mounting bracket for easier installation.

Made with Your Needs in Mind – We designed the Elastimold® Recloser only after extensive talks with electric utilities. Its features, from easier-to-see open/close indicators to the many robust extra features that we consider “standard”, are there because of you.

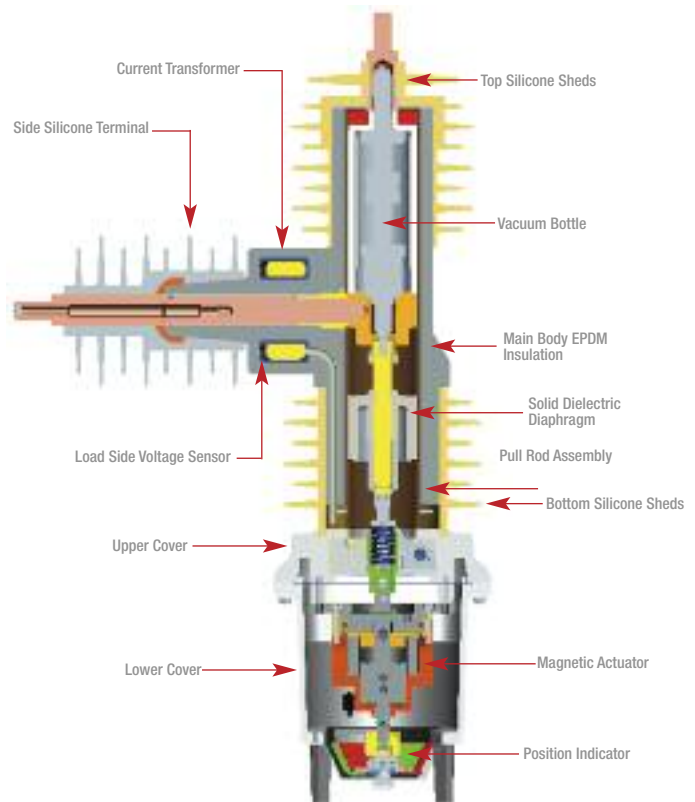
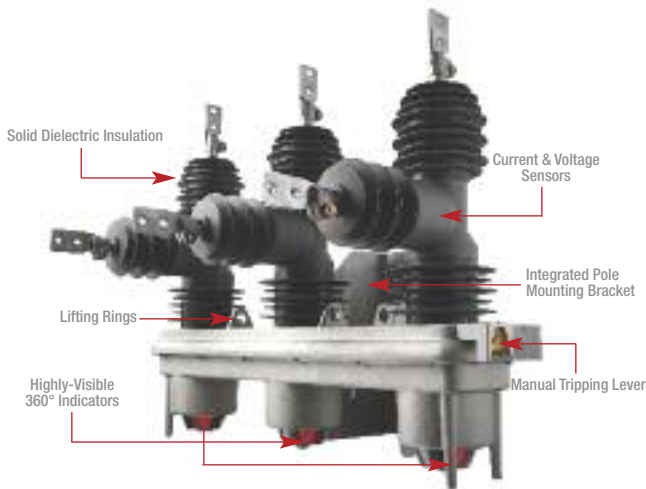

Recloser Operation

The Elastimold® Molded Vacuum Recloser (MVR) operates electrically by energizing a magnetic actuator system with a completely sealed housing. Each pole contains a vacuum interrupter sealed in solid dielectric insulation for mechanical and high dielectric strength.

An open-closed position indicator provides a 360-degree view. An external manual trip assembly is located on the side; when in the down position, it maintains the recloser in a lockout position until it is manually restored. All electrical control connections are made through a sealed single-environment control cable connector on the side.

The combination of the molded vacuum recloser with microprocessor controls accurately detects a wide range of line disturbances and provides reliable, high-speed isolation for adverse conditions.

Molded Vacuum Recloser

Catalogue Numbering System

Indicates field that must be filled in to complete order.

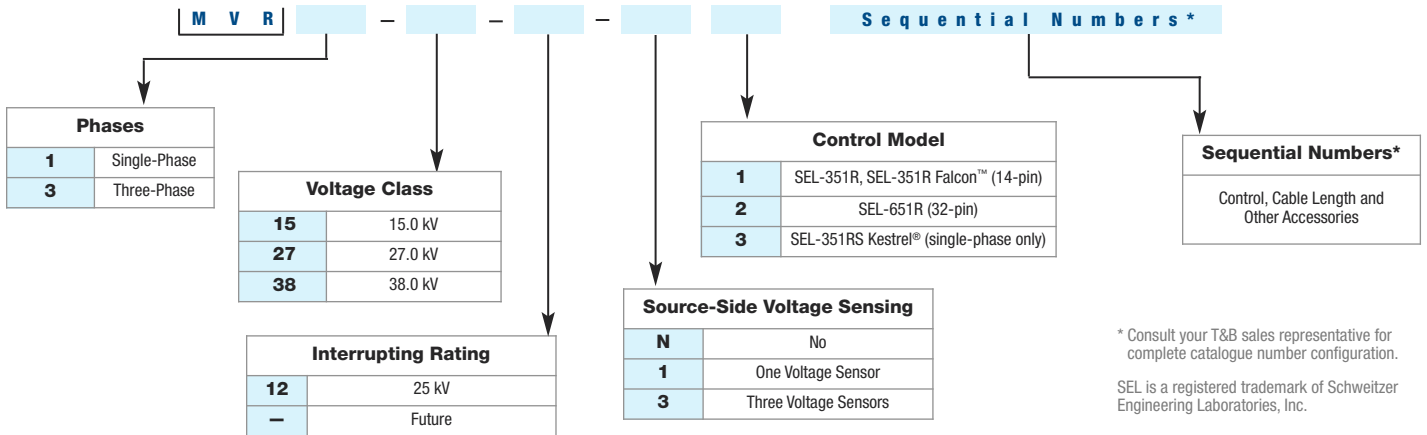

Accessories

Cat. No.	Description
3188D0120G1	Three-phase Line Side Arrester Frame
3188D0121G1	Three-phase Load Side Arrester Frame
3188C0122G1	Single-phase Line Side Arrester Frame
3188C0123G1	Single-phase Load Side Arrester Frame
3070A1191P1	Wildlife Protector Top Bushing (one per phase)
3070A1190P1	Wildlife Protector Side Bushing (one per phase)
3188C0075G1	Source-side Voltage Sensors (one per phase)
3188D0119G1	Substation Mounting Frame
3188B0126G1	NEMA 2-hole pad
3180A0661P1	NEMA 4-hole pad
3070B0913G1	Aerial Lug
1548FH-ANC3JNAA	Fisher Pierce® Overhead Faulted Circuit Indicator – Adaptive Trip™; 4 hr automatic reset time with current reset override (60 sec. after restoration of power), five ultra-bright LEDs for increase visibility display
1548FH-ANC3XNA1	Fisher Pierce® Overhead Faulted Circuit Indicator – Adaptive Trip™; 4 hr automatic reset time with current reset override (60 sec. after restoration of power), with 4 hr temporary fault reset time, temporary fault indication option, four red and one amber LED

Ratings and Specifications

	15 kV	27 kV	38 kV*		15 kV	27 kV	38 kV*
Nominal System Voltage (kV RMS)	14.4	25	35	Interrupting Current (kA RMS Symmetrical)	12.5	12.5	12.5
Rated Maximum Voltage (kV RMS)	17.1	29.3	38	Making Current (kA Asymmetrical Peak)	32.5	32.5	32.5
Nominal Frequency (Hz)	50 or 60	50 or 60	50 or 60	Creepage Distances (Inches — Line to Ground)	41.5	41.5	41.5
Phase Spacing on Three-Phase Units (Inches)	15.5	15.5	15.5	Arc-Extinction Medium	Vacuum	Vacuum	Vacuum
BIL (kV)	150	150	170	Insulation Medium	EPDM/Silicon Rubber	EPDM/Silicon Rubber	EPDM/Silicon Rubber
Power Frequency Withstand — Dry (kV)	50	50	70	Mechanical Operations	10,000	10,000	10,000
Power Frequency Withstand — Wet (kV)	45	45	60	Operating Temperatures	-40°C to 65°C	-40°C to 65°C	-40°C to 65°C
Continuous Current (A RMS)	800	800	800	Voltage Sensor Accuracy (Load/Line)	3% / 1%	3% / 1%	3% / 1%
Eight (8) Hour Overload Current (A RMS)	960	960	960	CT Accuracy	Class 1	Class 1	Class 1
CT Ratio	1,000 to 1	1,000 to 1	1,000 to 1	Weight (Single-Phase/Three-Phase)	57 lb. / 208 lb.	57 lb. / 208 lb.	58 lb. / 211 lb.

* Single phase 38 kV units are rated for use on grounded systems only. Three-phase 38 kV units can be used for single-phase tripping on grounded systems only. For ungrounded systems, three-phase tripping is required.