

# Lighting Controls

Centralized Lighting  
Control Panel Interior  
Catalog Number  
CLCINTxx

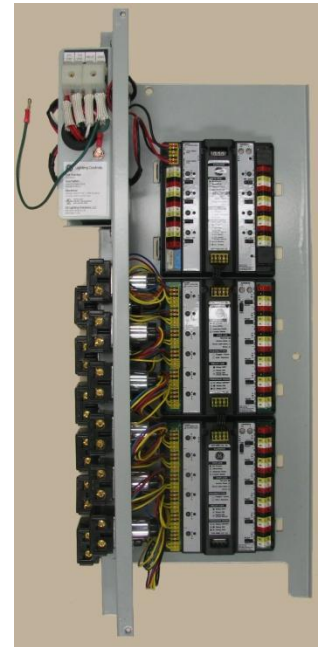

## DESCRIPTION

The Centralized Lighting Control System is a small network of relay panels and occupant control switches linked by a dataline. Together, these devices form a reconfigurable switching platform – one that uses “softwiring” instead of hardwiring to link occupant switches to relays. Scheduling capability can be readily added by simply adding a CLCDLS scheduler to the network.

The CLCINTxx is the interior for the Centralized Lighting Control System Relay Panel.

The complete relay panel assembly will include the following:

1. Tub (CLCTUBxx)
2. Interior (CLCINTxx)
3. Power Supply (CLCXFRxxx)
4. Cover (CLCCOVxxS)

This instruction sheet will describe:

1. Various components of the panel
2. Installation of the Relay Panel Interior
3. Initial set-up
4. Pushbutton programming/operation
5. Module replacement



imagination at work



## BEFORE YOU BEGIN

Read these instructions completely and carefully.

### ! WARNING

RISK OF ELECTRIC SHOCK

TURN OFF POWER BEFORE SERVICING  
INSTALL IN ACCORDANCE WITH NATIONAL  
ELECTRIC CODE

**CAUTION:** Make sure all power is off before wiring.  
Do not energize wiring until the unit is fully  
assembled. Conform to all applicable codes.

If you have questions, call GE Lighting Control Service  
at: 1-877-584-2685 (LTG-CNTL) in the USA and Canada.

# Installation Instructions

## RELAY MODULES

### CLCRM56

- Addressable
- Controls up to six GE RR9 relays
- Local push button control of individual relays
- One direct switch input per relay
- LED status indicator for each relay
- LED SYS status indicator
- LED COM status indicator
- Four position header for connection of power and network to other modules (up to 8 total)

### CLCRM6

- Addressable
- Controls up to six GE RR7 relays
- Local push button control of individual relays
- LED status indicator for each relay
- LED SYS status indicator
- LED COM status indicator
- Four position header for connection of power and network to other modules (up to 8 total)

### CLCRM56

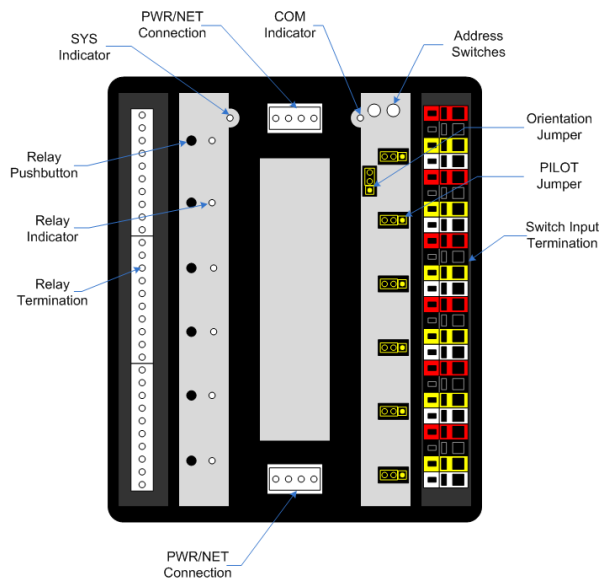

### CLCRM6

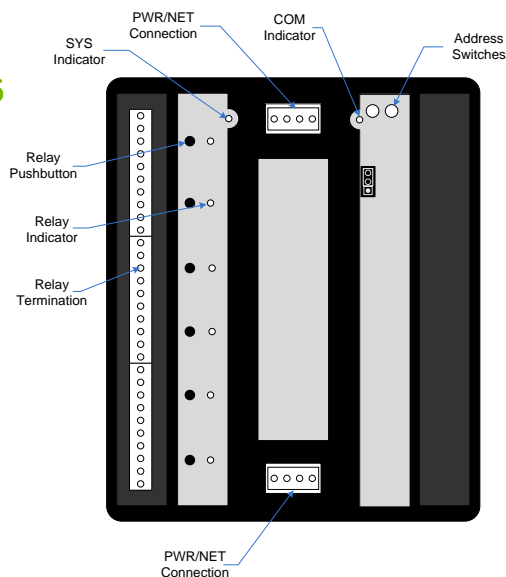

### Non-program Mode LED Description

LED	Description
SYS	<ul style="list-style-type: none"> <li>• Solid Green – device is powered, running normally</li> <li>• Flashing Green – device upgrade in progress</li> <li>• Solid Yellow – panel address conflict</li> <li>• Flashing Yellow – network address conflict</li> <li>• Solid Red – supply voltage is low</li> <li>• Flashing Red – fault in device</li> </ul>
COM	<ul style="list-style-type: none"> <li>• Flashing Green – normal network traffic</li> <li>• Flashing Yellow – error with data</li> <li>• Flashing Red – communication error detected</li> </ul>
Relay	<ul style="list-style-type: none"> <li>• Solid Red – relay is energized</li> </ul>

# Installation Instructions

## GROUP SWITCH/POWER INJECTOR MODULES

### CLCGSM8

- Addressable
- Control of up to 8 inputs (switches, photocell, motion)
- Scene programming
- Local push button control of individual groups
- Jumper for setting input to binary/analog
- Two RJ45 connectors for Power/Network in and out (remote devices, other panels)
- Connects power supply to system
- LED status indicator for each group
- LED SYS status indicator
- LED COM status indicator
- LED status indicators for IN and OUT
- Four position header for connection of power and network to other modules (up to 8 total)

### CLCPIM

- Two RJ45 connectors for Power/Network in and out (remote devices, other panels)
- Connects power supply to system
- LED status indicators for IN and OUT
- Four position header for connection of power and network to other modules (up to 8 total)

### CLCGSM8

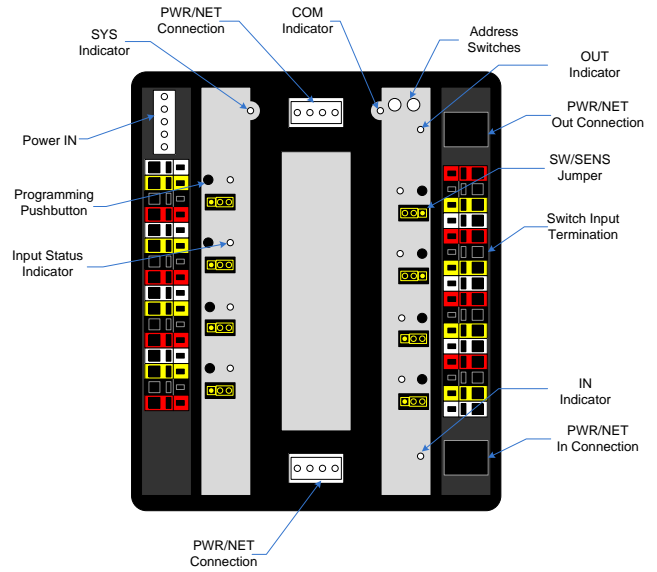

### CLCPIM

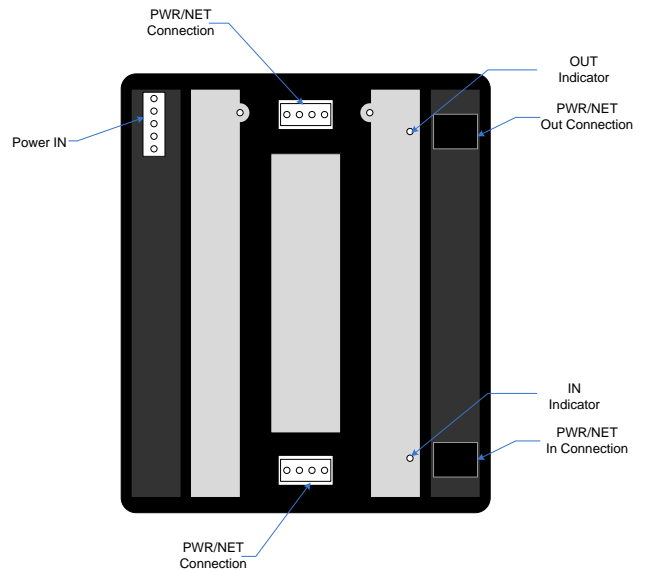

Non-program Mode LED Description	
LED	Description
* SYS	<ul style="list-style-type: none"> <li>• Solid Green – device is powered, running normally</li> <li>• Flashing Green – device upgrade in progress</li> <li>• Solid Yellow – panel address conflict</li> <li>• Flashing Yellow – network address conflict</li> <li>• Solid Red – supply voltage is low</li> <li>• Flashing Red – fault in device</li> </ul>
* COM	<ul style="list-style-type: none"> <li>• Flashing Green – normal network traffic</li> <li>• Flashing Yellow – error with data</li> <li>• Flashing Red – communication error detected</li> </ul>
IN/OUT	<ul style="list-style-type: none"> <li>• Solid Green – below rated power of supply</li> <li>• Solid Yellow – at rated power of supply</li> <li>• Solid Red – exceeding rated power of supply</li> <li>• No color – no power is present (Network IN)</li> </ul>
* INPUT STATUS	<ul style="list-style-type: none"> <li>• Solid Red – outputs are on or match state of scene</li> <li>• Solid Green – not all of outputs are on or match the state of the scene</li> <li>• Repeat Fading Red/Green – all/some of the outputs are in flick warn mode</li> </ul>

\* CLCGSM8 only

# Installation Instructions

## DATALINE SWITCH

### CLCSWTx

- Addressable
- Capacitive touch
- Fits in standard NA electrical box
- 1, 2, 4 and 8 button configuration - re-configurable in the field
- Programming "pad"
- LED status indicator for each switch position
- LED SYS/COM status indicator
- Two RJ45 connectors for Power/Network in and out

Non-program Mode LED Description	
LED	Description
SYS	<ul style="list-style-type: none"> <li>• Solid Green - device is powered, running normally</li> <li>• Flashing Green - device upgrade in progress</li> <li>• Solid Yellow - panel address conflict</li> <li>• Flashing Yellow - network address conflict</li> <li>• Solid Red - supply voltage is low</li> <li>• Flashing Red - fault in device</li> </ul>
Button	<ul style="list-style-type: none"> <li>• Solid Red - outputs are on or match state of scene</li> <li>• Solid Green - not all of outputs are on or match the state of the scene</li> <li>• Repeat Fading Red/Green - all/some of the outputs are in flick warn mode</li> </ul>

### Front view

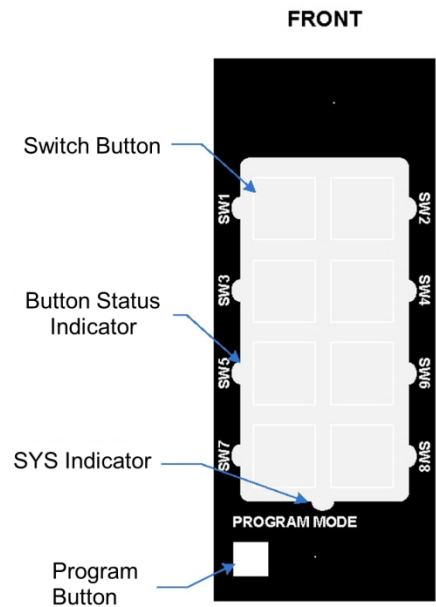

### Rear view

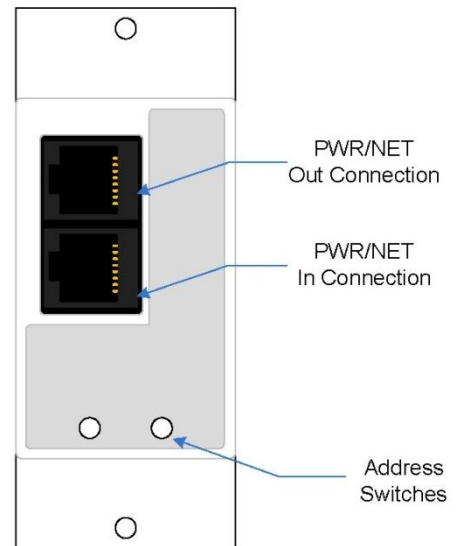

# Installation Instructions

## DATALINE SCHEDULER

### CLCDLS

- Addressable
- Touch screen
- Astronomical clock
- 8 weekly schedules with exceptions (single or reoccurring)
- 8 additional groups
- Can be used to configure system
- Two RJ45 connectors for Power/Network in and out

Front view

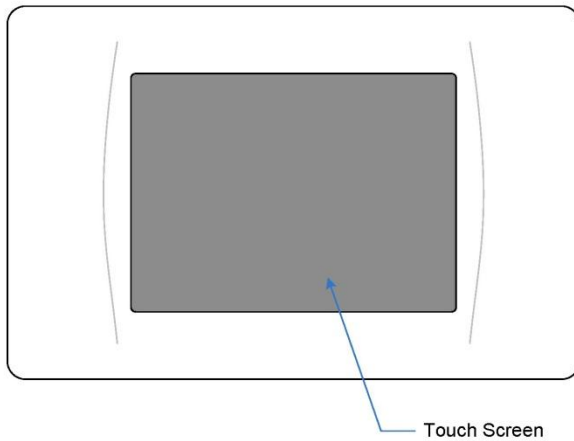

Rear view

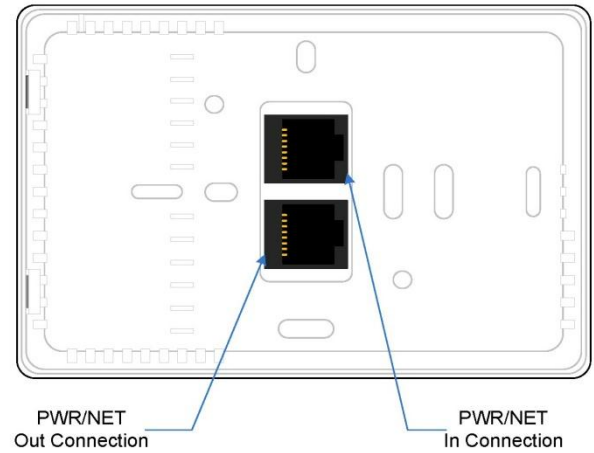

# Installation Instructions

## RELAY PANEL INSTALLATION

**FIGURE 1**  
**Dimension A**

CLCTUB12	23"
CLCTUB24	38"
CLCTUB36	49"
CLCTUB48	60"

**Mains Conduit Size**

CLCTUB12	1.5"/2"
CLCTUB24	1.5"/2"
CLCTUB36	2"/2.5"
CLCTUB48	2"/2.5"

**Low Voltage Conduit Size**

CLCTUBxx	0.5"/0.75"
----------	------------

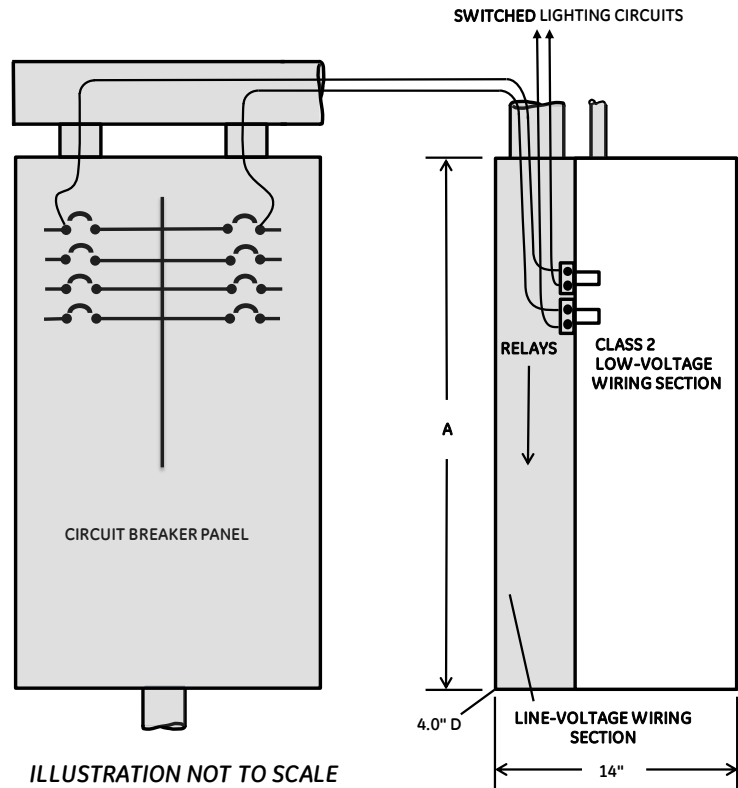

ILLUSTRATION NOT TO SCALE

**Rough-In Tub**

- Environment**  
32 to 131°F (0 to 55°C), 0 to 90% relative humidity, stationary applications
- Mounting**  
The tub should be level, plumb and rigidly installed with hardware sufficient to hold 75 lbs. (34kg). For multiple panels, allow 1/4" minimum between panels for showbox cover clearance.
- Pulling Wires**  
Route line-voltage wiring through the knockouts in either the top or bottom of the tub. Route Class 2 low-voltage dataline from the remote switches or other low voltage controls through the knockouts in top or bottom of the tub. Refer to Figure 1 for conduit sizes. Please note that in certain cases, the use of THHN/THWN wire may be required. This involves systems of ≥ 36 relays, single conduit for line voltage in/out, all wires ≥ 12 AWG.

**Install Interior**

- Power Supply**  
Locate opening in the left side of the interior . Feed secondary wires (2 pairs of Red and Black leads in connector) through opening. Align two captive screws on power supply with swaged standoff in Interior. Tighten two screws to secure power supply. Plug in power supply connector to mating header on either the CLCGSM or CLCPIM. The label is marked "24VAC 50/60HZ" next to the connector. See **Figure 2**.
- Interior**  
Mount the interior in the tub and secure it to the studs with the hardware provided. Do not completely tighten hardware at this time. The cover secures to the interior in several locations. To align cover to tub and interior, the interior may need to be adjusted side-to-side. Connect power supply ground wire to the hole in tub using green 8-32 screw (**Figure 3**). Make sure that all line- and low-voltage wiring is confined to the appropriate areas.

**Wire Line Voltage**

Before making any connections to the relays, make sure that none of the load circuits are shorted. Wire from the circuit breaker through each relay's SPST output terminals, and from there to the loads. Confirm that each circuit is wired to the relay specified in the drawings. Wire the power supply.

**Figure 2**

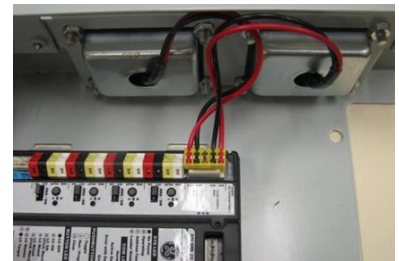

**Figure 3**



# Installation Instructions

## INITIAL SYSTEM SET-UP

1. Ensure that each device in network has a unique address. The maximum number of addressable devices on the network is limited to 99.
2. Wire remote switch(s) to CLCRMS6 relay module(s). A small flat head screwdriver should be used to apply pressure to connector for wire insertion. Two locations can be used, front and back. Refer to **Figure 4** for location and direction of pressure. Move jumper position if using "pilot" or "locator" switches. See **Figure 5**.
3. Wire remote switch(s) **Figure 4**, photo cell(s), occupancy sensor(s) to CLCGSM8. Move jumper to correct position, dependent on type of input. For a switch or closed contact input, move jumper to "SW". For photocell or occupancy sensor, move jumper to "SENS". See **Figure 6**.
4. Connect dataline switch(s) and/or dataline scheduler to the CLCGSM8/CLCPIM using CAT5 or higher UTP 4 pair 24AWG cable. The connection should start from the CLCGSM8/CLCPIM "PWR/NET OUT connection" and connect to the "IN" of the next device. Proceed from the "OUT" of that device in a daisy chain fashion to the remaining devices in the network. The length of the network is limited to 3,300 feet. The CLCGSM8/CLCPIM can connect up to eight CLCRM6/CLCRMS6 and the following combinations of CLCDLS and CLCSWTx:

CLCSWTx	CLCDLS
25	0
19	1
13	2
7	3
1	4

5. The network must be terminated on both ends. Install CLCTRM at both ends of the network.

Figure 5

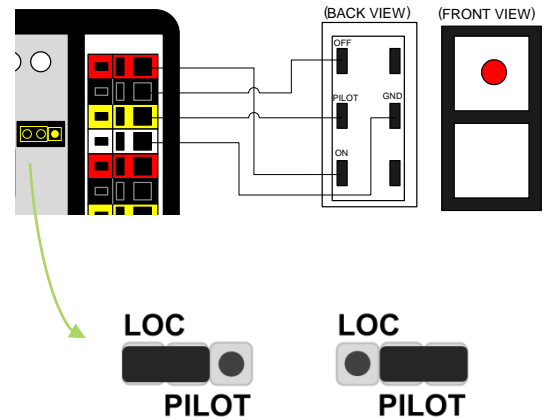

Figure 6

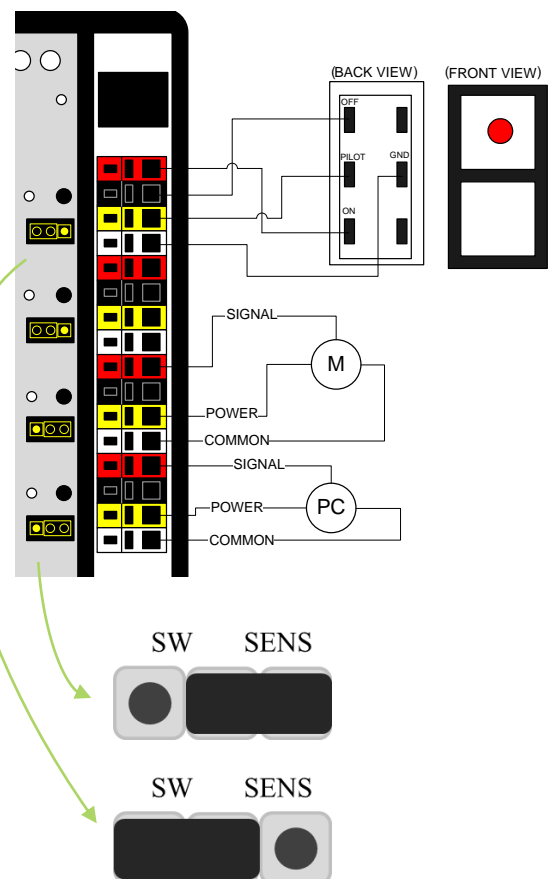
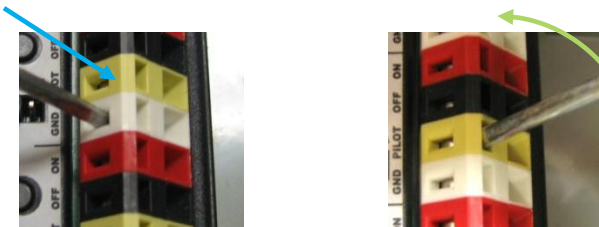

Figure 4  
(Arrow indicates direction of applied pressure)



# Installation Instructions

## INSTALL COVER

1. Align mounting holes in cover with holes in tub and interior. If necessary, adjust interior side-to-side.
2. Tighten hardware securing interior to tub.
3. Secure cover to tub/interior using supplied hardware.

## POWER UP AND TEST RELAYS

1. Apply power to the power supply only. As shown in **Figure 7**, to the right, press the Relay Pushbutton next to each relay's yellow plug-in termination to toggle it ON/ OFF. The relay should "click" and the Relay Indicator should change state. Confirm the operation by measuring the continuity at the line-voltage terminations of each relay.
2. Apply power to the relays. Being careful not to touch any line-voltage wiring, toggle each relay ON/OFF again and confirm that each relay controls the appropriate load.

Figure 7

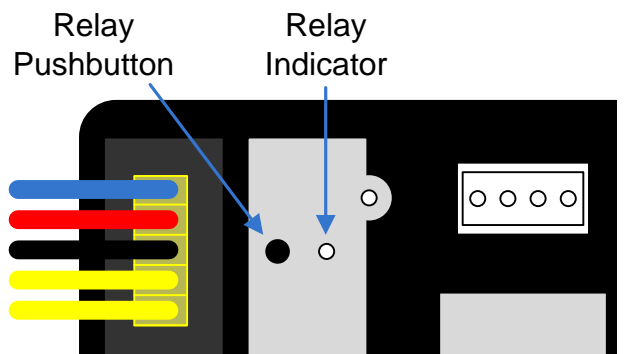

## DOCUMENT RELAY WIRING

Record the circuit controlled by each relay on the **RELAY SCHEDULE** which was shipped with the interior..

Figure 8

### RELAY SCHEDULE

PANEL # 01

RELAY #	SUPPLY	LOAD DESCRIPTION
-01	LP1-1	OPEN OFFICE – First Floor – NW
-02	LP1-2	OPEN OFFICE – First Floor – NW
-03	LP1-3	OPEN OFFICE – First Floor – NE
-04	LP1-4	OPEN OFFICE – First Floor – NE
-05	LP1-5	OPEN OFFICE – First Floor – SW



# Installation Instructions

## PUSHBUTTON PROGRAMMING

### Group Switch Module Input

1. Press and hold pushbutton for desired input for > 2 seconds. The LED next to pushbutton will flash red.
2. To add a relay to control – press and hold relay pushbutton > 2 seconds. Input will default to on/off type control. Select the desired control type by pressing pushbutton (on/off, on only, off only). LED color indicates control type selected.
3. Repeat step 2 to add other relay(s) to be controlled by this input.
4. To remove a relay already programmed - press and hold pushbutton > 2 seconds.
5. To exit programming of input, press and hold pushbutton for > 2 seconds.
6. To clear an input (remove all programming), press and hold pushbutton for > 10 seconds.
7. To add input as a Target for another input in programming mode: press and hold pushbutton for desired input for > 2 seconds. The LED next to pushbutton will flash green.

CLCRM6/CLCRMS6 Programming Mode LED Description	
LED Color	Control Type
Alternating Red/Green	Relay is ON/OFF controlled
Flashing Red	Relay can only be controlled ON
Flashing Green	Relay can only be controlled OFF
No Color	Relay is no longer controlled by input

### Dataline Switch Button

1. Remove switch plate from switch.
2. Touch programming pad (lower left corner) for > 2 seconds. The SYS LED will flash red.
3. Press desired switch button to program. The LED next to button will flash color based on current programming status (see table).
4. To add a relay to control – press and hold pushbutton > 2 seconds. Input will default to on/off type control. Select the desired control type by pressing pushbutton (on/off, on only, off only). LED color indicates control type selected.
5. Repeat step 2 to add other relay(s) to be control by this button.
6. Touch programming pad for > 2 seconds.
7. Touch switch button being programmed.
8. To clear a switch button, touch programming pad for > 10 seconds. The SYS LED will flash yellow. Touch switch button.
9. To add switch button as a Target for another input in programming mode: touch programming pad for > 2 seconds. The SYS LED will flash green. Touch desired switch button to add as a target.
10. Attach switch plate to switch.

CLCSWTx Switch Button Programming Mode LED Description	
LED Color	Control Type
Flashing Red	Button already has targets
Flashing Green	Button is a target of another input
Flashing Yellow	Button does not have assigned targets

## PUSHBUTTON OPERATION

### Group Switch Module

Press and hold pushbutton for desired input for < 2 seconds. For a group in “off” or “mixed” (LED is green) mode, targets will be commanded “on”. For a group in “on” (LED is red) mode, targets will be commanded “off”.

### Relay Module

Press the pushbutton for desired relay. The pushbutton will toggle the state of the

### Dataline Switch Button

Touch the desired switch button. For a group in “off” or “mixed” (LED is green) mode, targets will be commanded “on”. For a group in “on” (LED is red) mode, targets will be commanded “off”.

# Installation Instructions

## MODULE REPLACEMENT

### Group Switch Module

1. Remove power supply plug (reference **Figure 2**).
2. Tag and remove wire(s) connected to switch input(s) (reference **Figure 4**).
3. Tag and remove dataline from PWR/NET connectors.
4. Pull up on module jumper (**Figure 8**) to remove.
5. Apply pressure to right side of module (**Figure 9**) – lift module from interior.
6. Insert new module – slide left side plastic tabs under sheet metal tabs (**Figure 10**), push down on right side to lock into place.
7. Set address to match removed module.
8. Install module jumper.
9. Connect dataline as noted in Step 3.
10. Reconnect wire(s) to switch input(s) as noted in Step 2.
11. Connect power supply plug to module (**Figure 2**).

Figure 8



Figure 9



### Relay Module

1. Pull up on module jumper(s) (**Figure 8**) to remove.  
Note: depending on module location, there may be two jumpers that need removed (top and bottom).
2. Pull up on connectors to disconnect relay connections from module (**Figure 11**).
3. If applicable, tag and remove wire(s) connected to switch input(s) (reference **Figure 4**).
4. Apply pressure to right side of module (**Figure 9**) – lift module from interior.
5. Insert new module – slide left side plastic tabs under sheet metal tabs (**Figure 10**), push down on right side to lock into place.
6. Set address to match removed module.
7. Reconnect wire(s) to switch input(s) as noted in Step 2.
8. Reconnect relay connections to module. Relay numbers are located on interior side.
9. Install module jumper(s).

Figure 10



Figure 11

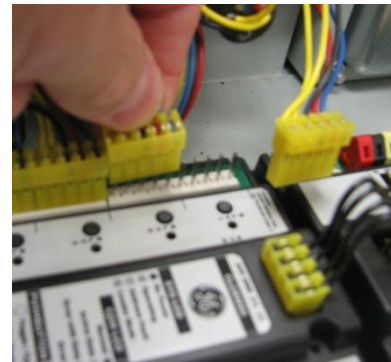

These instructions do not cover all details or variations in equipment nor do they provide for every possible contingency that may be met in connection with installation, operation or maintenance. Should further information be desired or should particular problems arise that are not covered for the purchaser's purposes, the matter should be referred to the GE Company. Information provided is subject to change without notice.

For additional product and application information,  
please consult GE's Website: [www.gelighting.com](http://www.gelighting.com)