

Fig. 4 Double Harness Lead Connection Lead Calcium Batteries

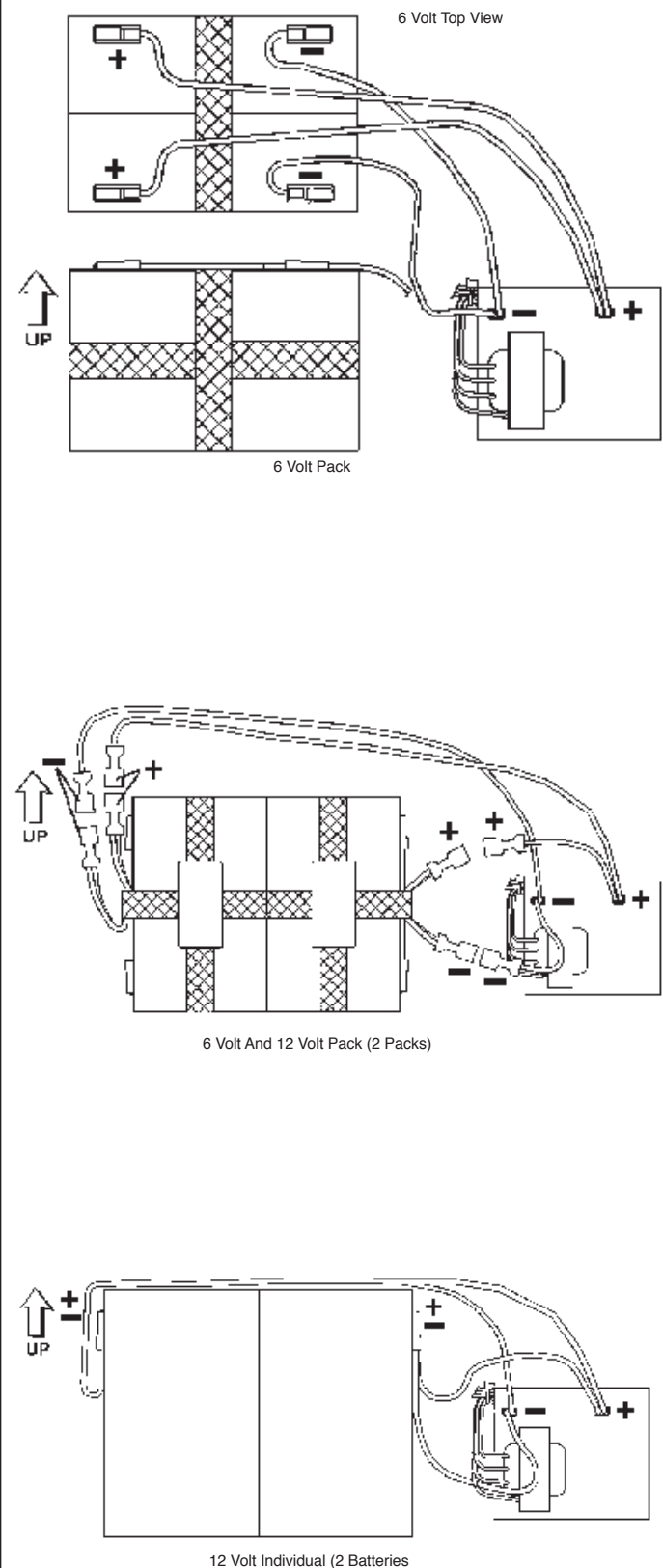

Fig. 5 Single Harness Lead Connection Nickel-Cadmium Batteries

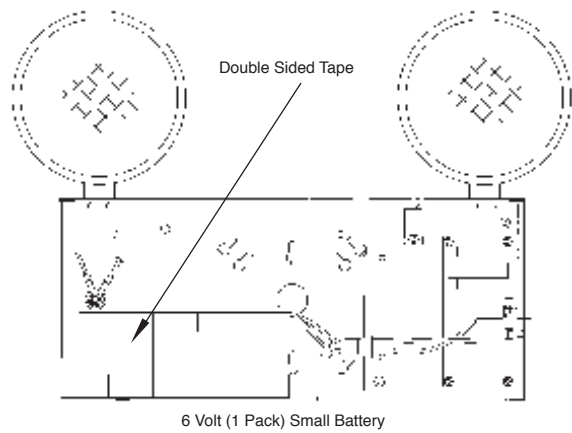
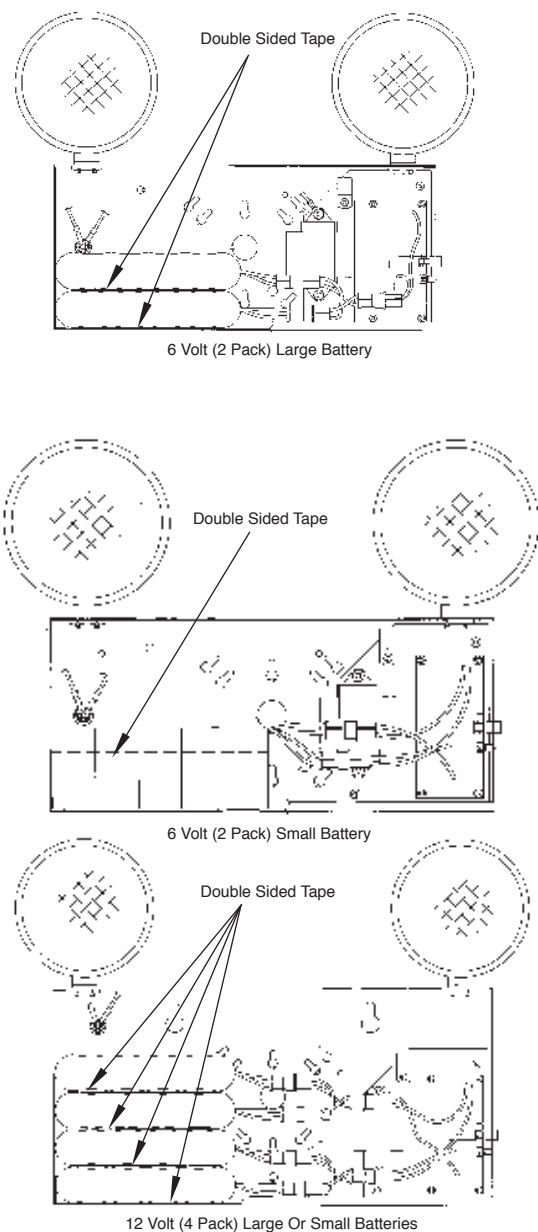
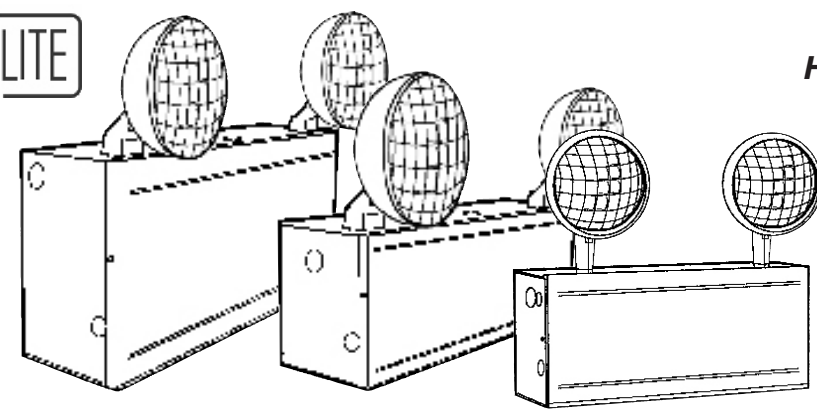

Fig. 6 Double Harness Lead Connection Nickel-Cadmium Batteries



DUAL LITE



LM Series
High-Capacity Emergency Lighting Units

Installation Instructions For Standard,
Remote Capacity And Damp
Location Models

IMPORTANT SAFEGUARDS

When using electrical equipment, basic safety precautions should always be followed including the following.

READ AND FOLLOW ALL SAFETY INSTRUCTIONS

1. Do not use outdoors.
2. Do not mount near heaters or hot surfaces.
3. Equipment should be mounted in locations and at heights where it will not readily be subject to tampering by unauthorized personnel.
4. The use of accessory equipment not authorized by the manufacturer may cause an unsafe condition.
Caution: Halogen cycle lamps may be used in this equipment. Halogen cycle lamps operate at high temperatures. Do not store or place flammable materials near lamp. To avoid shattering: Do not operate lamp in excess of rated voltage. Protect lamp against abrasion and scratches and against liquids when operating. Dispose of lamp with care.
5. Do not use this equipment for other than its intended purpose.
6. Servicing of this equipment should be performed by qualified service personnel.

SAVE THESE INSTRUCTIONS

WARNING – This product contains chemicals known to the State of California to cause cancer, birth defects and/or other reproductive harm. Thoroughly wash hands after installing, handling, cleaning, or otherwise touching this product.

EMERGENCY LIGHTING AND POWER EQUIPMENT FOR USE IN DAMP LOCATIONS

Damp location listed units are suitable for use in:

1. Interior locations subject to moderate degrees of moisture, such as some basements, some barns, some cold-storage warehouses, and the like.
2. Partially protected locations under canopies, marquees, roofed open porches and the like.

GENERAL INSTRUCTIONS

This unit is designed for surface mounting on a wall or other solid surface (building support structure, column, etc.). Unit must be mounted high enough to maximize illuminated area under anticipated conditions of use. Be sure to allow ample clearance for mounting and aiming the lighting heads.

Provide each unit with a single unswitched power supply from a 120 or 277VAC branch circuit used for normal lighting in the same area. The wiring should be permanent installation, using appropriate size wire.

Note: De-energize AC circuit to unit during initial installation, and during servicing or relamping operations.

PLACING THE UNIT IN SERVICE

1. Loosen the two cover retaining screws on the sides of the unit, rotate the heads for clearance, and remove the cover by lifting it up and outwards.
2. If lighting heads will be retained in the top mounted position, go to step 3. If lighting heads are to be relocated to side mounted position, proceed as follows:
 - a. Snap out the lighting head knockouts on the sides of the unit.
 - b. Loosen the locking nut that retains the stem for each lighting head.
 - c. Slide each lighting head out of its present slot.
Note: It is not necessary to disconnect the lighting head leads from the circuit board.
 - d. Insert the stem of each lighting head into the side opening slots.
 - e. Tighten the locking nut on each stem so that the lamp heads turn with some resistance.
 - f. Plug the top mounted opening slots with the hole plugs contained in the hardware pack.
3. Fasten enclosure to electrical outlet box and/or wall surface using appropriate hardware.
Note: The enclosure can be mounted to 3" x 4" octagon, or 4" square electrical boxes, and to standard plaster rings. Large enclosures have additional keyhole slots for surface mounting. A 7/8" diameter knockout is provided on the top and on each side of the enclosure for surface wiring conduit.



- Identify unit as using either:
 - lead calcium batteries** (standard models, i.e. LM30, LMP66) or
 - nickel cadmium batteries** (model number ending with "N", i.e. LM30N, LMP50N-12V)
- Connect remote lamps (if used) to blue (+, fused) and yellow (-) leads (Fig. 1 or Fig. 2).
- Connect 120 or 277VAC input connections to transformer (Fig. 1 or Fig. 2). Connect green wire to building ground.

Note: insulate the unused transformer lead to prevent potential shock hazard.

Note: LM33I-03L with Spectron must use a minimum of 12W in total to obtain lamp sensitivity adjustment.

•Units Supplied With Lead Calcium Batteries

- Determine proper battery orientation from Fig. 3 (single harness lead connection) or Fig. 4 (double harness lead connection). Battery is positioned to the left of the circuit board. Remove protective liner from double sided tape, located on floor of enclosure.

Note: a 1/4" space (minimum) is required between the front of the battery and the inner lip of the enclosure to provide clearance for cover. Place battery into enclosure, and press down firmly to secure battery to enclosure.
- Connect positive (+, red) and negative (-, yellow) battery harness leads from printed circuit board to corresponding battery terminals as shown in Fig. 3 or Fig. 4.
- Check all wiring for loose or missing connections.
- Replace cover. Be sure that each "star washer" is properly positioned between the screw head and the outer surface of the cover. Tighten retaining screws. Adjust lighting heads to desired position.
- Energize unit with AC power. Press and hold the "TEST" button (see Fig. 1 for "TEST" button location) to confirm illumination and proper aiming of emergency lamps. ("AC ON" indicator LED should go off). Release the "TEST" button; emergency lamps should extinguish. Normal operation begins.
- Normal Operation: with power supplied, "AC ON" LED indicator is illuminated and emergency lamps are off.

•Units Supplied With Nickel Cadmium Batteries

- Determine proper battery orientation from Fig. 5 (single harness lead connection) or Fig. 6 (double harness lead connection). Battery is positioned to the left of the circuit board. Remove protective liner from double sided tape, located on the battery.

Note: a 1/4" space (minimum) is required between the front of the battery and the inner lip of the enclosure to provide clearance for cover. Place battery into enclosure, and press down firmly to secure battery to enclosure.
- Connect battery harness leads from printed circuit board to corresponding battery harness leads as shown in Fig. 5 or Fig. 6.
- Check all wiring for loose or missing connections.
- Replace cover. Be sure that each "star washer" is properly positioned between the screw head and the outer surface of the cover. Tighten retaining screws. Adjust lighting heads to desired position.
- Energize unit with AC power.

Note: allow unit to charge for 24 hours prior to testing. Press and hold the "TEST" button (see Fig. 2 for "TEST" button location) to confirm illumination and proper aiming of emergency lamps. ("AC ON" indicator LED should be off). Release the "TEST" button; emergency lamps should extinguish. Normal operation begins.
- Normal Operation: with power supplied, "AC ON" LED indicator is illuminated and emergency lamps are off.

ROUTINE TEST CYCLING

- Monthly: If there has been no power failure, press and hold the "TEST" button for at least thirty (30) seconds to confirm emergency lamp operation. Release "TEST" button to return to battery charging mode.
- Once a year: Perform a full battery conditioning cycle by de-energizing the AC circuit to which the unit is connected, and allow the unit to operate for ninety (90) minutes on battery power. Following successful test, energize AC circuit to begin battery charging cycle.

Note: AC ON LED blinks when battery is fully charged.

REPLACING EMERGENCY LAMPS AND BATTERIES

General

- De-energize the AC power supply to the unit.
- Remove enclosure cover.
- Disconnect positive (+, red) battery lead (*nickel cadmium models*- disconnect battery and printed circuit board connectors).

•Emergency Lamp

Plastic Sealed Beam Type Heads

- Gently pry lamp lens at arrow indicator marks to remove lens.
- Replace lamp.

Plastic Sealed Beam Heads

- Pry to remove outer ring.
- Replace lamp.

Metal Heads

- Gently pry retaining ring out of groove to access lamp.
- Replace lamp.

•Battery

- Remove defective battery. Recycle responsibly. Replace with genuine manufacturer battery only.
- Place new battery in enclosure. Make connections following steps outlined above.
- Test unit.

Fig. 1 Pure-Lead Or Lead-Calcium Battery

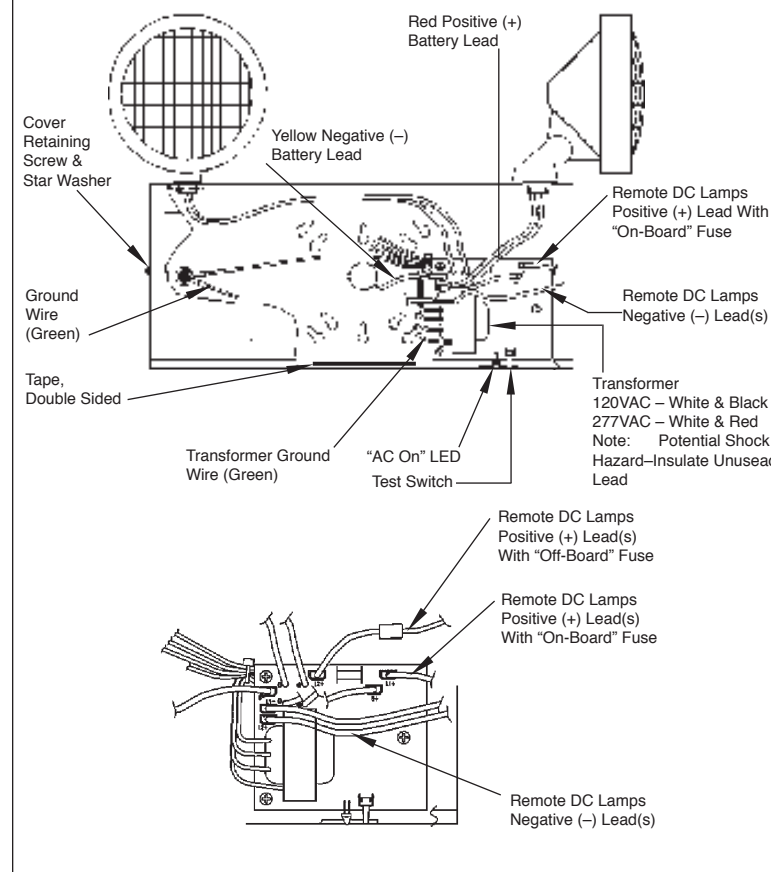

Fig. 2 Nickel-Cadmium Battery

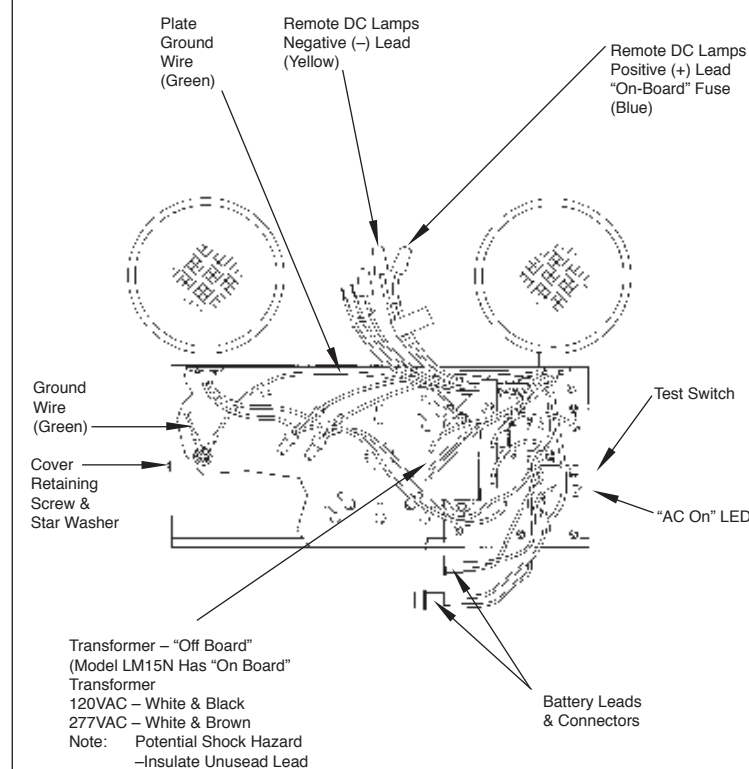

Fig. 3 Single Harness Lead Connection Pure-Lead Or Lead-Calcium Batteries

