



Wattstopper®

Wide-Angle Occupancy Sensor • Passive Infrared Low Voltage (V3)

No: 24732 – 09/16 rev. 1

Installation Instructions • Instructions d'Installation • Instrucciones de Instalación

Catalog Number • Numéro de Catalogue • Número de Catálogo: FS-705

Country of Origin: Made in China • Pays d'origine: Fabriqué en Chine • País de origen: Hecho en China



SPECIFICATIONS

Power Supply	24VDC from Wattstopper Class 2 Power Pack only
Current Consumption	7mA@24VDC
Dimensions.....	3.15" front to back x 2.68" W x 1.77" H
	(80mm front to back x 68mm W x 45mm H)
Weight	2.17 oz. (60 grams)
Temperature ranges:	
Operating	32° to 131°F (0° to +55°C)
Storage.....	-22° to 176°F (-30° to +80°C)
Detection indicator.....	Red LED

DESCRIPTION AND OPERATION

The FS-705 is a low-voltage passive infrared (PIR) occupancy sensor designed to control lighting where wide-angle 180° coverage is desired. It is ideally suited for use in aiseways with refrigeration systems, and in freezer cases, vending machines, and display areas. It is designed to turn on cabinet lights when it detects people in the aisle, then turn the lights off when the aisle is vacant, after a time delay expires. To connect to a dimming system, contact Technical Support.

It is a low voltage device used in conjunction with a Wattstopper 24VDC Class 2 power pack.

COVERAGE PATTERN

The sensor contains dual pyros and a lens providing 40 detection zones, ensuring dense coverage within the detection area. The sensor provides true 180° horizontal and 70° vertical coverage.

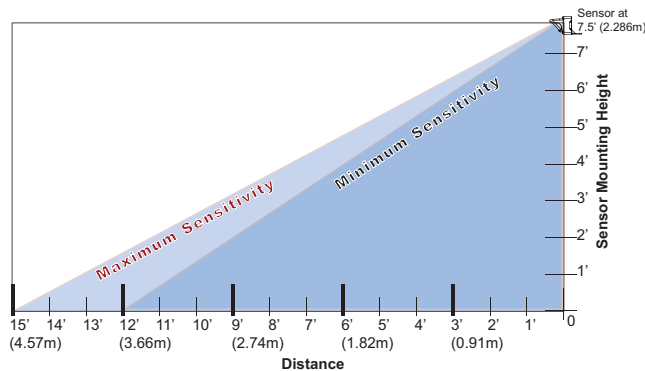
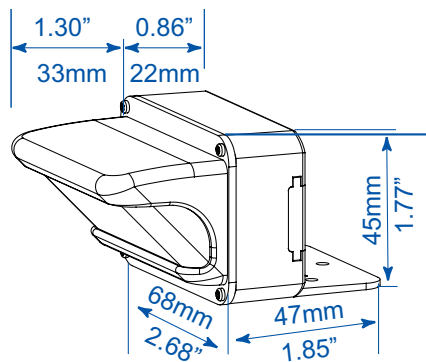

Side View

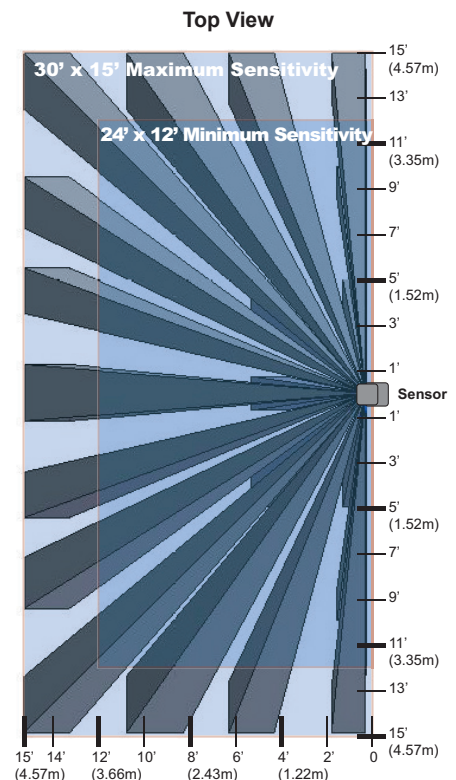

Top View

INSTALLATION

Determine an appropriate mounting location for the FS-705. Mount the FS-705 on top of the cabinet in the center for equal coverage on either side. Place the front edge of the sensor at the front edge of the cabinet. Secure the sensor to the top of the cabinet with self tapping screws.

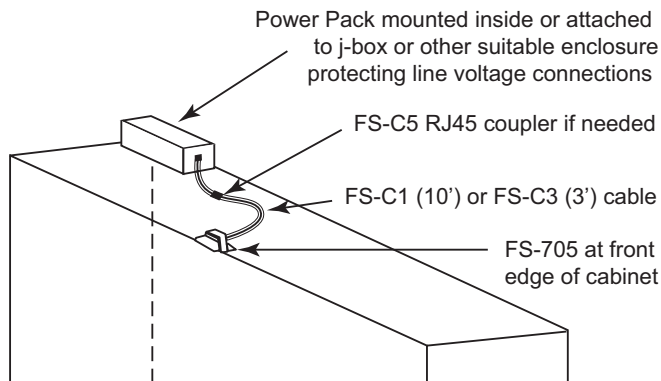

Figure 1: Installing on a freezer unit

BZ-SERIES Power Packs

Attach a BZ-SERIES power pack to a junction box through a ½ inch knock-out. Install the power pack according to instructions provided with the unit.



WIRING

For custom configurations, including connections to dimming controls and building automation systems, contact Technical Support at 1-866-588-5473.

Low Voltage Connections

Connect the low voltage wiring to the power pack as shown in the wiring diagram for the power pack you are using.

BZ-50RC Power Pack

See Figure 2

BZ-50 Power Pack

See Figure 3

BZ-150 Power Pack

See Figure 4

Line Voltage Connections

1. Connect the black wire and one of the red wires to the non-switched hot.
2. Connect the white wire to the neutral.
3. Connect the other red to the switch leg.

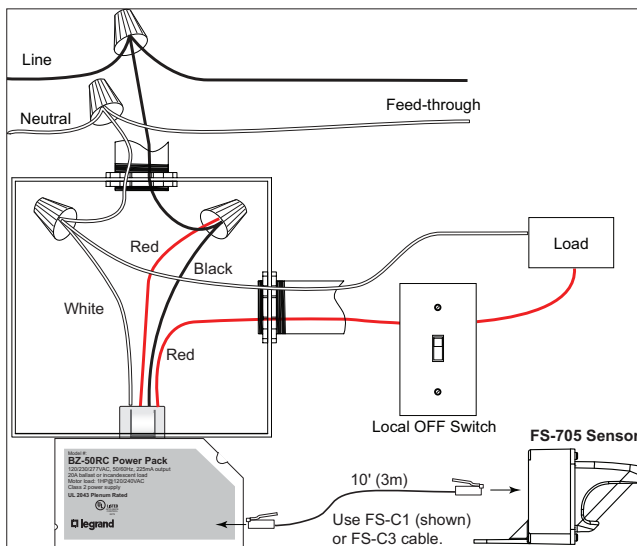

Figure 2: BZ-50RC Power Pack connected to FS-705 using an FS-C1 or FS-C3 cable

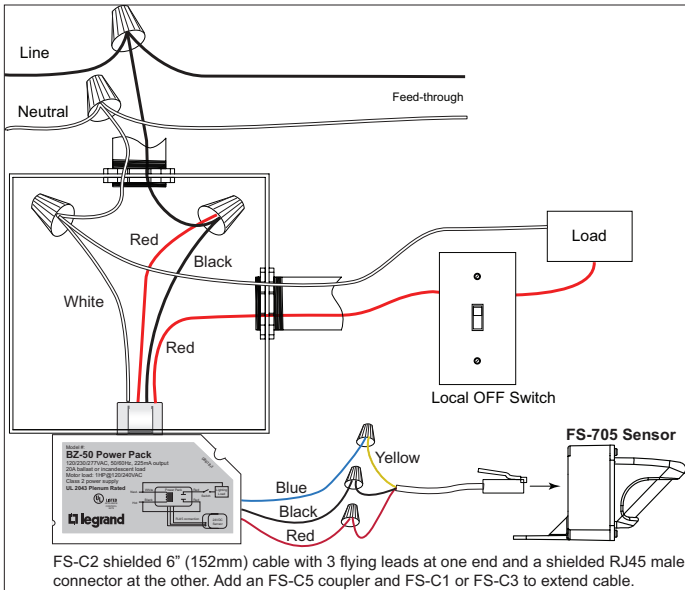

Figure 3: BZ-50 Power Pack connected to FS-705 using an FS-C2 adaptor

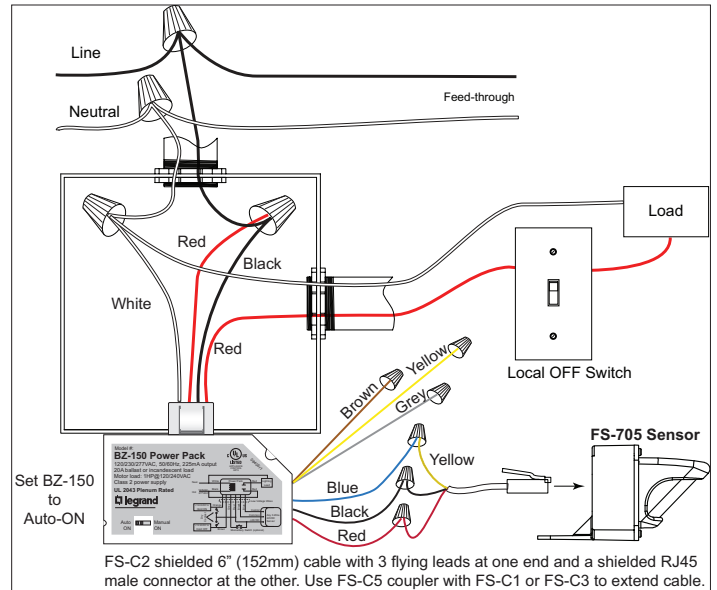

Figure 4: BZ-150 Power Pack connected to FS-705 using an FS-C2 adaptor

ADJUSTMENTS

The Time Delay and PIR Sensitivity adjustments are located on the back of the FS-705 under a removable cover. The sensors are factory preset for maximum sensitivity and a 30-second time delay.

Switch Settings

Sensitivity	1			
Minimum
Maximum	+	.	.	.
Time Delay	2	3	4	
30 second
1 minute	.	+	.	.
2 minutes	.	.	+	.
8 minutes	.	.	.	+

+=ON ,=OFF

TEST OCCUPANCY SENSOR

IMPORTANT: There is an initial warm-up period:

It may take up to a minute for the sensor to warm up during the initial power-up. The sensor has an "instant on" feature. This occurs during installation or after a lengthy power failure only. As soon as power is supplied to the power pack, the lights will come **ON** and stay **ON** for approximately 1 minute. If no movement is detected within that time, the lights will turn **OFF** until detection occurs. If movement is detected during the initial 1 minute, then the lights will stay **ON** for whatever time has been set on the time delay.

1. Turn the time delay to minimum.
2. Move out of the sensor's view. Lights should turn **OFF** after 30 seconds.
3. Walk down the aisle. When the first sensor detects motion the red LED in the sensor will flash and the first cooler's lights should turn on.
4. Proceed down the aisle, the second cooler's sensor should detect you, the red LED in the sensor will flash and the second cooler's lights should turn **ON**.
5. This process should continue down the rest of the aisle. As you walk down the aisle, the cooler lights should progressively turn **ON** prior to you walking in front of that cooler, turning on one at a time as you proceed down the aisle.
6. Repeat this process from the opposite end of the aisle. No matter which direction you approach, the system should function in this way.

TROUBLESHOOTING

Lights will not turn on:

Sensor LED does not flash when motion is within the coverage zone of the detector:

Is the Red LED on the power pack flashing?

- If no, check circuit breaker. Check all wiring to power pack and all RJ45 connections between sensors and power pack. Test a different sensor connected directly to the power pack.
- If **yes**, check wiring to power pack and all RJ45 connections between sensors and power pack. The power pack LED will continuously blink to indicate that the Over Current Mode has been activated. During an over current event, the +24VDC output is turned off and the relay opens. Upon removal of the Over Current condition, the BZ will not attempt to restore the power for 10 seconds after an over-current event.

Sensor LED does flash when motion is within the coverage zone of the detector:

- Check all wire connections and verify the load wires are tightly secured at the power pack. The power pack LED will blink once every 5 seconds to indicate when the relay is closed.
- Check the light switch.
- If lights still do not turn on, call 866-588-5473 for technical support.

Lights will not turn off:

The time delay on the sensor can be set from 30 seconds to 8 minutes. Ensure that the time delay is set to the desired delay and that there is no movement within the sensor's view for that time period. To quickly test the unit for proper operation, set the time delay to minimum and move out of the sensor's view. Lights should turn off after 30 seconds.

- If lights still do not turn off, disconnect the sensors from the power pack. The lights should turn off.
 - ▶ If the lights remain on even with nothing connected to the power pack, check the high voltage wiring of the power pack. If all of the wiring is correct and the lights are still on, replace the power pack.
 - ▶ If the lights turn off with nothing connected to the power pack, check the low voltage wiring and connections.
- If lights still do not turn off, call 866-588-5473 for technical support.

ORDERING INFORMATION

Catalog Number	Description
FS-705	Wide-Angle PIR Sensor, 24VDC
BZ-50	Power Pack with flying leads for connecting low voltage wires
BZ-50RC	Power Pack with RJ45 jack for connecting low voltage wires
BZ-150	Power Pack with flying leads for connecting low voltage wires, hold-on/hold-off inputs, plus manual or auto mode option
FS-C1	One 10' cable with a shielded RJ45 male connector at each end
FS-C2	One 6" (152mm) cable with 3 flying leads at one end and a shielded RJ45 male connector at the other or use with BZ-50 or BZ-150 power packs.
FS-C3	One 3' cable with a shielded 90° RJ45 male connector at one end and a shielded straight male RJ4 connector at the other end, for space-limited areas
FS-C4	Shielded RJ45 splitter with female to dual female receptacles
FS-C5	Shielded RJ45 male-to-male coupler

WARRANTY INFORMATION

Wattstopper warrants its products to be free of defects in materials and workmanship for a period of five (5) years. There are no obligations or liabilities on the part of Wattstopper for consequential damages arising out of, or in connection with, the use or performance of this product or other indirect damages with respect to loss of property, revenue or profit, or cost of removal, installation or reinstallation.

INFORMATIONS RELATIVES À LA GARANTIE

Wattstopper garantit que ses produits sont exempts de défauts de matériaux et de fabrication pour une période de cinq (5) ans. Wattstopper ne peut être tenu responsable de tout dommage consécutif causé par ou lié à l'utilisation ou à la performance de ce produit ou tout autre dommage indirect lié à la perte de propriété, de revenus, ou de profits, ou aux coûts d'enlèvement, d'installation ou de réinstallation.

INFORMACIÓN DE LA GARANTÍA

Wattstopper garantiza que sus productos están libres de defectos en materiales y mano de obra por un período de cinco (5) años. No existen obligaciones ni responsabilidades por parte de Wattstopper por daños consecuentes que se deriven o estén relacionados con el uso o el rendimiento de este producto u otros daños indirectos con respecto a la pérdida de propiedad, renta o ganancias, o al costo de extracción, instalación o reinstalación.