

WARNINGS AND CAUTIONS:

- TO BE INSTALLED AND/OR USED IN ACCORDANCE WITH ELECTRICAL CODES AND REGULATIONS.
- YOU ARE NOT SURE ABOUT ANY PART OF THESE INSTRUCTIONS, CONSULT AN ELECTRICIAN.
- FOR INDOOR USE ONLY.

DESCRIPTION:

The ceiling-mounted Occupancy Sensor saves energy and adds convenience by accurately detecting when an area is occupied or vacant. It is wireless, solar-powered, and uses a passive infrared (PIR) sensor to detect motion. The occupancy sensor transmits RF signals that control lighting, HVAC and outlets to manage building energy consumption more efficiently.

- Sends wireless signals to receiving devices whenever motion is detected.
- Harvests indoor light to power the sensor and wireless communications.
- Works with other sensors for enhanced occupancy tracking.
- Built-in tests to confirm operation at installed location.
- Supplemental battery or alternative power supply options for extreme low-light conditions.

If occupation is detected by the permanently active PIR sensor, a radio telegram indicating the occupied status will transmit immediately. An internal timer starts to run for 120 seconds. No radio telegrams will be sent out when the timer is counting down.

After the timer has finished the countdown, the unit will transmit again if occupancy was detected during the countdown time period. If occupancy is not detected, the unit will transmit a heartbeat signal - sending the unoccupied status with a random timing of 2 to 12 minutes. There are two buttons which allow entrance to a "Walk" or "Light-level" test mode. These test modes are for installation purposes only and will be exited automatically after 3 minutes.

PLANNING:

Take a moment to plan for the sensor's successful operation and optimal communication with other system components. Remove the sensor from its packaging and place it under a bright light to provide the required startup charge. Optional: To quickly ensure the sensor energy storage is fully charged, insert a CR2032 battery for 5 minutes.

- Ensure the location provides consistent and adequate light.
- Locate the sensor on the ceiling between 8 and 10 ft. (2.4 to 3 m) high with an unobstructed view of the space.
- Consider the area's traffic patterns and principal use, for example, walking, lounging or sleeping.
- Provide a minimum clearance of 4 ft. (1.2 m) away from heat sources, light bulbs, forced air, or ventilation systems.
- Consider the construction materials (such as metal) in the space and obstacles that may interfere with RF signals.

COMPATIBLE DEVICES:

This product is compatible with LevNet RF Advanced Wireless Wall Switches only.

Reference the following catalog numbers:

- WSS10-0UZ • WSS10-GUZ
- WSS10-AUZ • WSS10-UAZ

NOTE: This product will not work with LevNet RF Basic Wireless Wall Switches.

EQUIPMENT NEEDED FOR INSTALLATION:

- Power drill, 3/16" bit
- Screwdriver
- Leveling tool
- Light meter
- Battery (CR2032) for testing

INSTALLATION:

The occupancy sensor can be mounted on most ceilings with the provided screws, or mounted on dropped ceilings, using the provided wire bracket.

NOTE: It is often easier to link the sensor before it is mounted on the ceiling. Refer to the "Programming and Activation" section.

1. Decide where you want to install the occupancy sensor.
2. Remove the mounting plate from the sensor.
3. Decide which of the two installation options is appropriate.

A. Screw Mounting Plate to the Ceiling.

- i. Hold the mounting plate in place on the ceiling and use a pencil to lightly mark two small dots for the screw drill points.
- ii. Drill two holes with a 3/16" drill bit and insert the anchors. (see figure 1)
- iii. Insert the first screw loosely and level the mounting plate.
- iv. Insert the second screw then hand-tighten the first screw.

B. Mount Using the Wire Bracket. (see figures 2 through 6)

- i. Remove the ceiling tile where you want to mount the sensor.
- ii. Place the mounting plate squarely on the ceiling tile and use the wire to mark two points for the holes.
- iii. Punch two small holes through the ceiling tile at the marked points
- iv. Insert the wire bracket through the two holes in the mounting plate. Make sure the ends are roughly even.
- v. Feed the wires through the holes in the ceiling tile.
- vi. On the front of the ceiling tile, flatten the wire bracket so it is snug against the mounting plate.
- vii. On the back of the ceiling tile, twist the wires together to hold the mounting plate securely.

4. Attach the sensor to the mounting plate. With the 2-button interface facing you, slide the sensor to the left on the mounting plate until it snaps into place. (see figure 6)
5. Confirm the sensor is properly positioned to detect motion and has sufficient light to operate, see the Walk Test and Light Test sections.

PROGRAMMING AND ACTIVATION:

Two or more compatible devices can be linked and configured to provide the desired control. There are two basic types of devices in the system; transmitters and transceivers.

- Transmit-only: Transmitters are simple energy-harvesting devices that send RF messages to communicate a condition, level, or state. Transmitters can only be linked to transceivers. Examples > Self-powered Light Switches, Occupancy Sensors.

- Transmit & Receive: Transceivers are controlling devices that send as well as receive RF messages. They also process relevant control logic, and actuate the appropriate outputs (switching a light on or off for example). Transceivers can be associated with transmitters as well as other transceivers. A transceiver can have up to 30 devices associated to it. Examples > Relays, Gateways

The Occupancy Sensor is a Transmit-only Device. To associate the occupancy sensor to a transceiver; the transceiver must first be powered, within wireless range, and set to accept associations. Next, the desired transmitter, or another transceiver, is triggered to send a special association/programming message. The awaiting transceiver receives and stores the association permanently so the devices can interact to provide a variety of intelligent control options.

To associate or disassociate an Occupancy Sensor:

1. Set the desired transceiver to accept an association (refer to that device's installation guide).
2. Click the Menu button on the side of the sensor once. This sends a associate/disassociate radio telegram (see figure 7). **NOTE:** The button interface on the sensor is used for associating and testing only. The occupancy timer settings are configured on the transceiver to which the sensor is associated.

Refer to the "Programming and Activation" section of the transceiver/controller installation guides to complete the linking process.

TESTING:

Before starting a test, ensure the sensor's energy storage is fully charged by placing it under bright light (at least 500 lux) for 20 minutes, or insert a battery for 5 minutes.

If a battery is used to charge the sensor for a light test, ensure it is removed to get an accurate light measurement.

A test mode will stay active for 3 minutes. To exit a test and resume normal operation, press and hold the Menu button for 5 seconds.

Walk Test

Use the walk test to confirm that motion is within the sensor's range.

1. Press and hold the Set button for 5 seconds.
 - Red LED will blink to confirm that a walk test is active.
2. Move in and out of the sensor's range to determine its coverage area.
 - Sensor will blink when it detects motion.
3. Make small hand movements just inside the limit of the sensor's range to see if the motion triggers a response.

Light Test

Use the light test to measure real-time light levels and confirm whether the occupancy sensor has sufficient light.

1. Create a realistic lighting condition (the test measures the real-time light level).
2. Press and hold the Set button for 10 seconds.
 - Red & green LEDs will blink to confirm light test is active.
3. Watch the LED blink rate to determine the light strength.
 - The highest is 5 blinks which indicates very good light (200 lux or more). 1 blink indicates minimum light (25 lux).

NOTE: If there is no blink rate, consider relocating the sensor or installing a battery to provide supplemental power. If the sensor does not have a sufficient charge, it cannot enter the test modes. No LED light or 1 red blink when the set button is pressed indicates insufficient charge.

INSTALLING SUPPLEMENTAL BATTERY (OPTIONAL):

If light levels are very low where the sensor is installed, auxiliary battery power (CR2032) can be used to supplement the solar energy harvester.

1. Remove the sensor from the mounting plate.
2. Identify the battery holder on the circuit board.
3. Insert the battery under the clip with the positive pole (+) up and press it in place (see figure 8).
4. Replace cover and remount the sensor on the wall.

TROUBLESHOOTING:

Sensor does not generate a wireless message:

- Verify the LED blinks when motion is detected during a walk test.
- Verify the solar cell is charged properly.

Sensor is activated when there is nothing to detect:

- Verify there is 4 ft. (1.2 m) clearance from heat sources that may disturb sensing.
- Reduce sensitivity setting by moving the PIR sensitivity switch on the back to low (the left-hand position).

Linked device does not respond to wireless messages:

- Check for environment or range issues.
- Verify the device is linked.
- Check the transceiver connection and the wiring for errors.
- Check if appropriate devices are linked according to good system planning.

Explanation of Occupied & Heartbeat Message Data Telegrams:

- Data Byte 3: Super Capacitor Voltage, 0-250 (0-5V).
- Data Byte 2: Solar Panel Current, 0-127 microA.
- Data Byte 1: 0xFF (occupied) or 0x00 (unoccupied).
- Data Byte 0: 0x09 (wall sensor) 0x0B (ceiling sensor).

SPECIFICATIONS	
Cat. No. WSC1x-M9N	
Field of View	See Field of view below
Frequency / Range	902 MHz / 50-150 feet
Power Supply	Solar Powered, Battery for backup (optional)
Light Required to Sustain Operation	50 lux for 30 transmissions per hour 100 lux for 60 transmissions per hour
Charge Time for Full Charge	3 Hours @ 200 lux (after startup) 6 Hours @ 200 lux (cold Start)
Environmental	Indoor Use Only 14° to 104°F (-10° to 40°C) 20% to 95% relative humidity (non-condensing)
Charge Time before Linking	2 Minutes @ 50 lux
Radio Certification	FCC (United States) SZV-STM300U I.C. (Canada) 5713A-STM300U

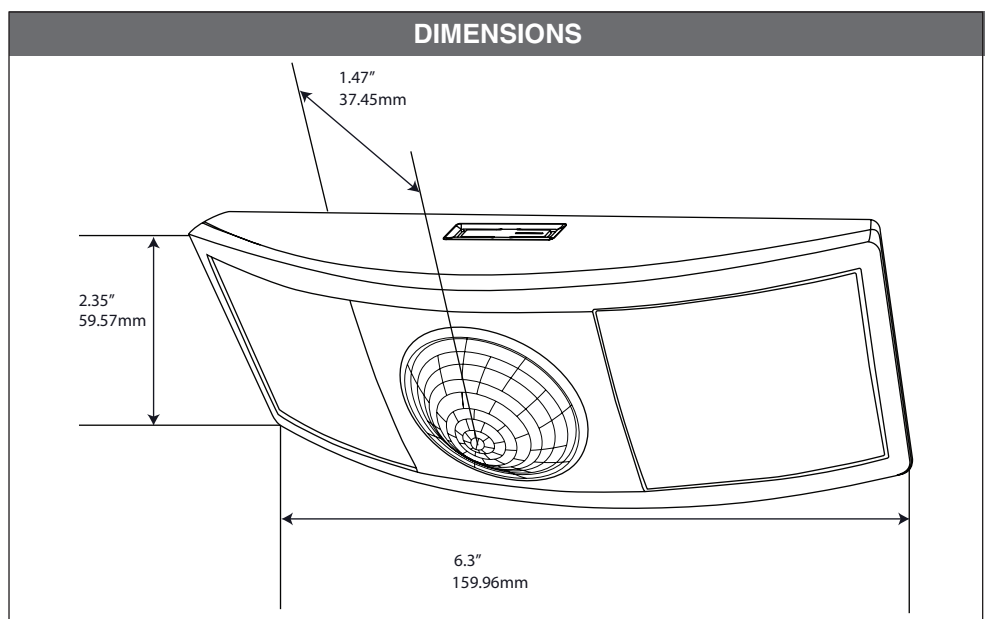

Figures

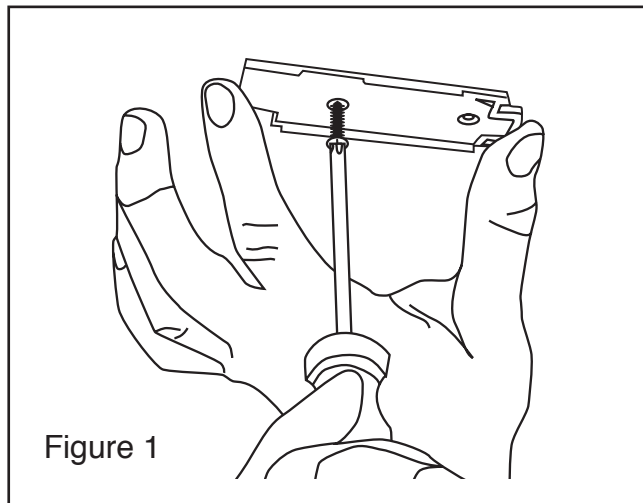

Figure 1

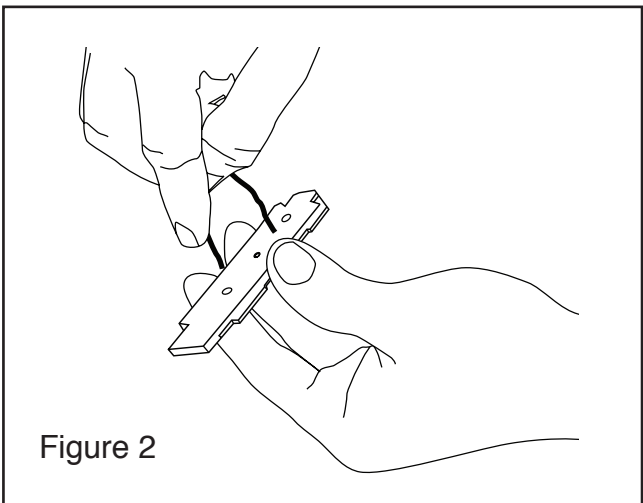

Figure 2

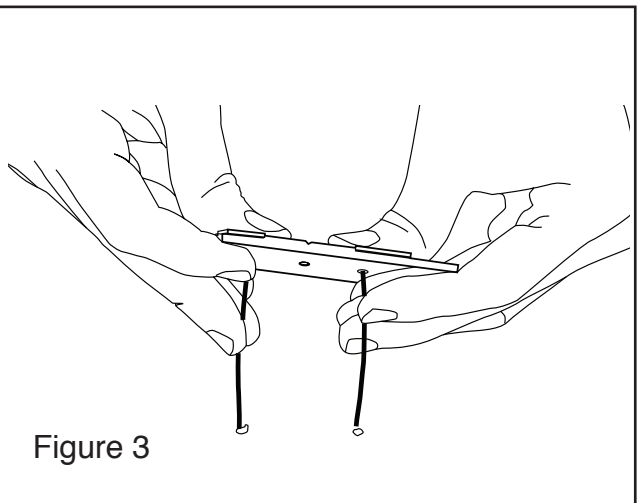

Figure 3

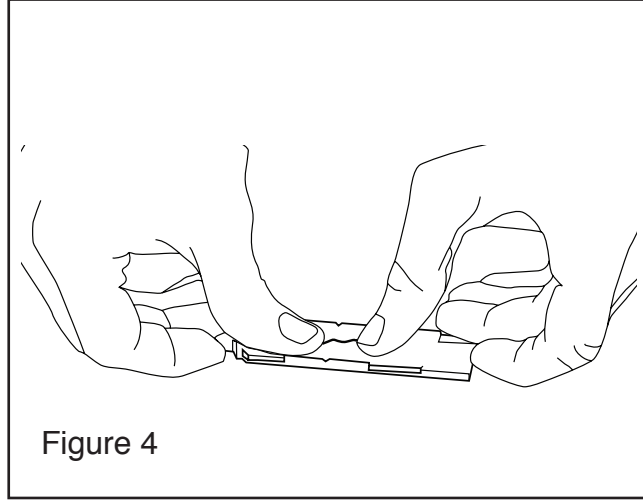

Figure 4

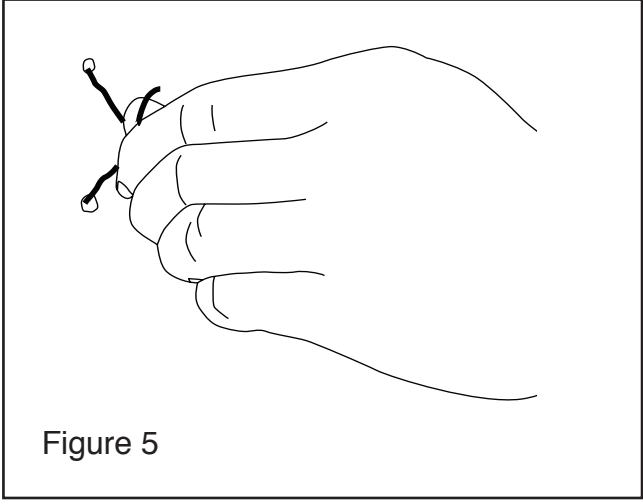

Figure 5

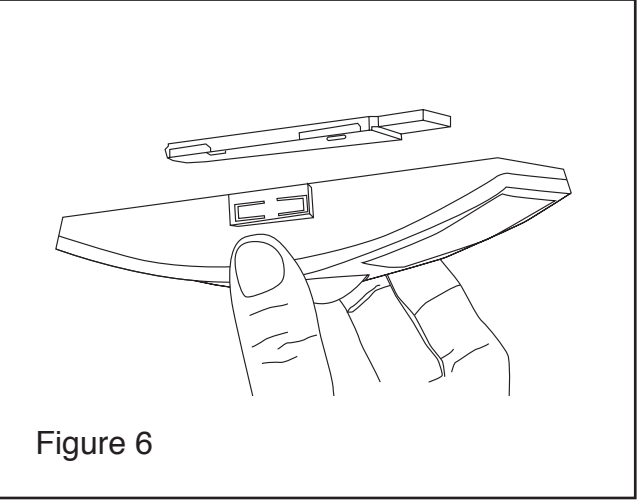

Figure 6

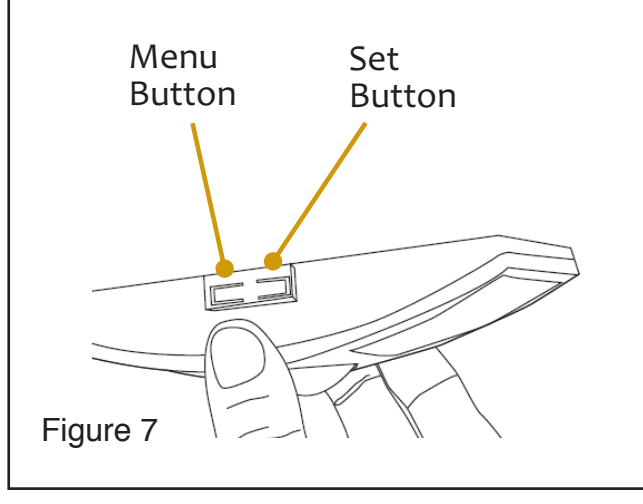

Figure 7

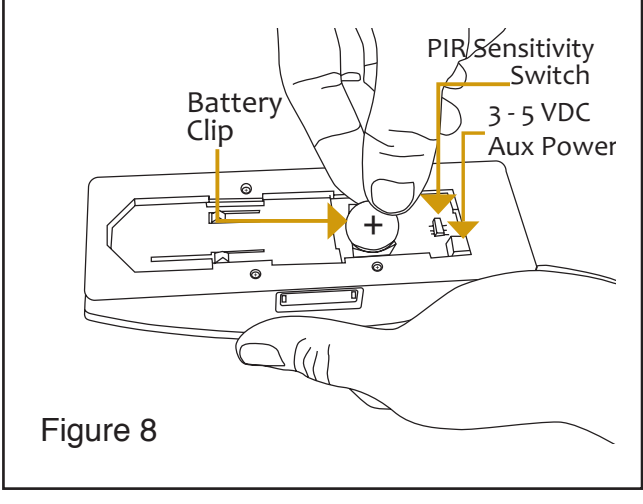
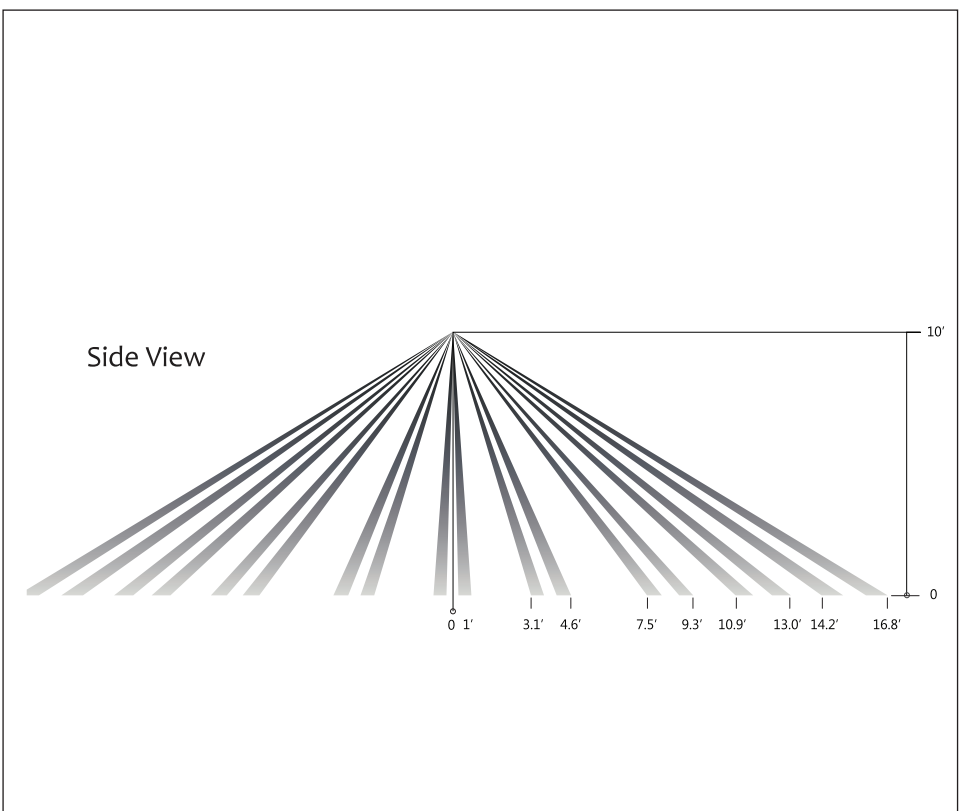
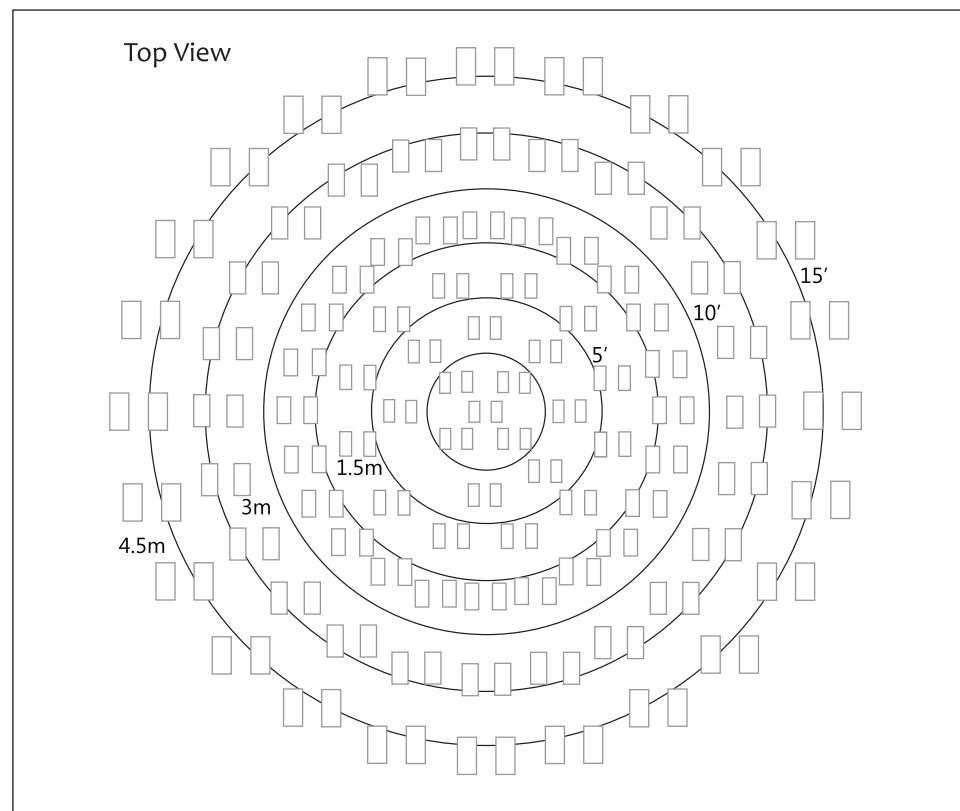

Figure 8



Ceiling Sensor



Note: A single occupancy sensor provides sufficient coverage for most applications. For some applications, multiple sensors may be required to provide complete coverage.

FCC COMPLIANCE STATEMENT:
 FCC ID: SZV-STM300U IC: 5713A-STM300U
 The enclosed device complies with Part 15 of the FCC Rules.
 Operation is subject to the following two conditions:
 (i.) This device may not cause harmful interference
 (ii.) This device must accept any interference received, including interference that may cause undesired operation.

Leviton is a registered trademark of Leviton Mfg. Co. in the United States, Canada, Mexico, and other countries. Other trademarks herein are the property of their respective owners.

These products are covered by one or more U.S. & Foreign Patents and Patents Pending
 Copyright © 2012 Leviton Manufacturing Co., Inc.
 All rights Including Trade Dress Rights Reserved

LIMITED 2 YEAR WARRANTY AND EXCLUSIONS

Leviton warrants to the original consumer purchaser and not for the benefit of anyone else that this product at the time of its sale by Leviton is free of defects in materials and workmanship under normal and proper use for two years from the purchase date. Leviton's only obligation is to correct such defects by repair or replacement, at its option, if within such two year period the product is returned prepaid, with proof of purchase date, and a description of the problem to Leviton Manufacturing Co., Inc., At: Quality Assurance Department, 201 North Service Road, Melville, New York 11747. This warranty excludes and there is disclaimed liability for labor for removal of this product or reinstallation. This warranty is void if this product is installed improperly or in an improper environment, overloaded, misused, opened, abused, or altered in any manner, or is not used under normal operating conditions or not in accordance with any labels or instructions. There are no other or implied warranties of any kind, including merchantability and fitness for a particular purpose, but if any implied warranty is required by the applicable jurisdiction, the duration of any such implied warranty, including merchantability and fitness for a particular purpose, is limited to two years. Leviton is not liable for incidental, indirect, special, or consequential damages, including without limitation, damage to, or loss of use of, any equipment, lost sales or profits or delay or failure to perform this warranty obligation. The remedies provided herein are the exclusive remedies under this warranty, whether based on contract, tort or otherwise.

FOR CANADA ONLY

For warranty information and/or product returns, residents of Canada should contact Leviton in writing at Leviton Manufacturing of Canada Ltd to the attention of the Quality Assurance Department, 165 Hymus Blvd, Pointe-Claire (Quebec), Canada H9R 1E9 or by telephone at 1 800 405-5320.

ARTWORK PRINT SPECIFICATIONS



PART NUMBER DI-001-WSC1x-05A **REV** 1 **DESCRIPTION** Instruction sheet

SPECIFICATIONS :

Dimensions: <u>11" x 17"</u> * Thickness: <u>40 lb.</u> * Material: _____ * Finish: _____ _____ : _____ * For manuals - designates cover specifications	* Color(s): <u>1</u> over <u>1</u> 1: <u>Black</u> <input checked="" type="checkbox"/> Spot 2: _____ <input type="checkbox"/> CMYK 3: _____ 4: _____	* Fonts: 1: _____ 2: _____ 3: _____ 4: _____
--	--	--

Die Line Key: - . . . - Perforate
 _____ Die Cut - - - - - Fold Line - - - - - Kiss Cut Cellophane ||||| Glue

MANUAL INTERIORS / BINDERY / FOLD SCHEME :

Body Material: _____ Thickness: _____ Bindery <input type="checkbox"/> Die cut <input checked="" type="checkbox"/> Fold <input type="checkbox"/> Saddle Stitch <input type="checkbox"/> Perfect Bind <input type="checkbox"/> Drill <input type="checkbox"/> Trim	Color(s): _____ over _____ 1: _____ <input type="checkbox"/> Spot 2: _____ <input type="checkbox"/> CMYK 3: _____ 4: _____	Fonts: 1: _____ 2: _____ 3: _____ 4: _____
---	--	--

PROCESS :

Offset Flexo
 Other _____
 Line Screen: _____
 Angle: _____
 Resolution: _____

FOLD SCHEME / BINDERY DIAGRAM

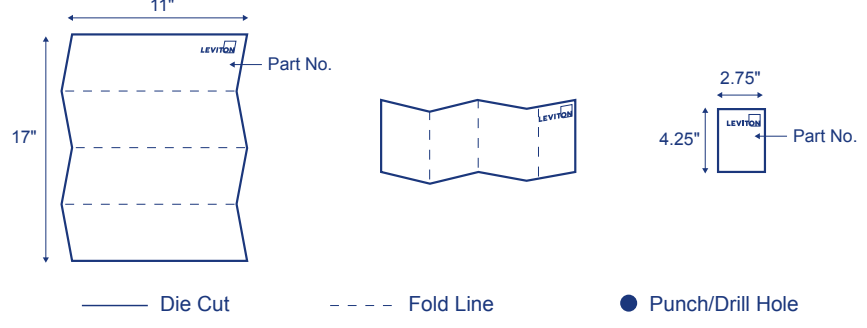

COMMENTS :

The information in this document is the exclusive PROPRIETARY property of LEVITON MANUFACTURING COMPANY, INC. It is disclosed with the understanding that acceptance or review by the recipient constitutes an undertaking by the recipient. (1) to hold this information in strict confidence, and (2) not to disclose, duplicate, copy, modify or use the information for any purpose other than that for which disclosed.

FOR LEVITON USE ONLY

Approvals: Plant 90 J. Smith CQA _____ PM B Carberry
 Mktg _____ Eng _____ S & A _____
 Cust _____ Other _____ Other _____

PN-ARN: _____ ECO Number: _____ Pilot Rev: _____

Artist: _____ Artwork Release Date: 9/25/14

Notes: _____