

IMPORTANT SAFEGUARDS

When using electrical equipment, basic safety precautions should always be followed including the following:

INSTALLATION INSTRUCTIONS INSTRUCTIONS D'INSTALLATION

READ AND FOLLOW ALL SAFETY INSTRUCTIONS

1. **DANGER**- Risk of shock- Disconnect power before installation.
DANGER - RISQUE DE CHOC - COUPER L'ALIMENTATION AVANT L'INSTALLATION
2. **CAUTION** – Installation and servicing should be performed by qualified personnel only. De-energize before opening.
ATTENTION – *L'installation et l'entretien doivent être effectués par du personnel qualifié seulement. Mettre hors tension avant l'ouverture*
3. To reduce the risk of electric shock, disconnect both standard and emergency power supplies and convert connector of the emergency driver before servicing.
Pour réduire le risque de décharge électrique, vous devez déconnecter à la fois le disjoncteur divisionnaire ou les fusibles et les alimentations d'urgence avant l'entretien.
4. Do not use outdoors.
Ne pas utiliser à l'extérieur.
5. Do not let power supply cords touch hot surfaces.
Ne laissez pas les cordons d'alimentation toucher les surfaces chaudes.
6. Do not mount near gas or electric heaters.
Ne montez PAS près des appareils de chauffage de gaz ou électriques.
7. Use caution when servicing batteries. Battery acid can cause burns to skin and eyes. If acid is spilled on skin or eyes, flush acid with fresh water and contact a physician immediately.
Faites preuve de prudence lors de l'entretien des batteries. L'acide de batterie peut provoquer des brûlures de la peau et les yeux. Si l'acide est versé sur la peau ou les yeux, rincer à l'eau acide frais et contacter un médecin immédiatement.
8. Equipment should be mounted in locations and heights where it will not readily be subjected to tampering by unauthorized personnel.
L'équipement doit être monté dans des endroits et à des hauteurs où il ne sera pas soumis à des altérations par des personnes non autorisées.
9. The use of accessory equipment not recommended by the manufacturer may cause an unsafe condition.
L'utilisation d'accessoires non recommandés par le fabricant peut causer une situation dangereuse.
10. Suitable for damp locations.
Convient Aux Emplacements Humides.
11. Max. mounting height: 12 ft.
Hauteur de montage max.: 12.
12. Access above ceiling required. Do not install insulation within 3" (76mm) of any part of the luminaire.
Accès requis au-dessus du plafond. Ne pas mettre l'isolant à moins de 3 po (76 mm) de toute partie du luminaire
13. Suitable for suspended ceilings.
14. Do not handle energized module with wet hands or when standing on wet or damp surfaces, or in water.

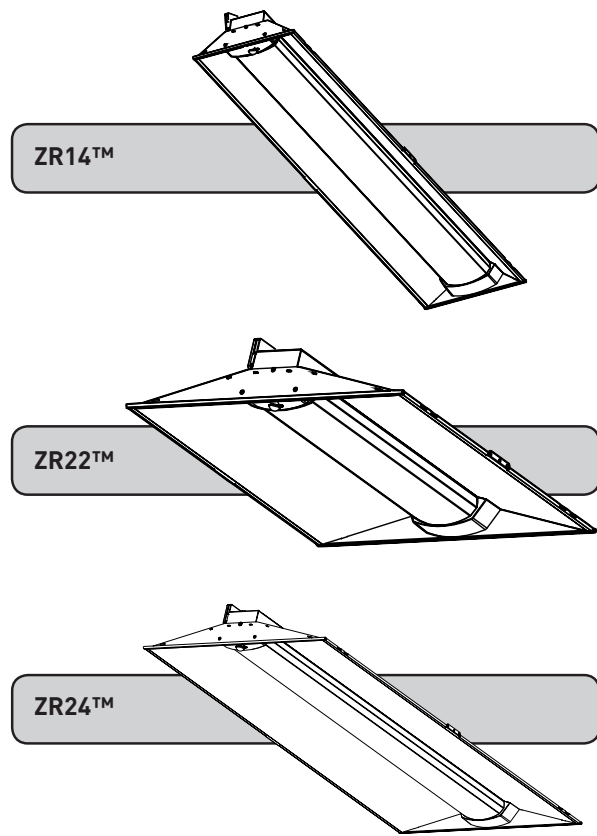

SAVE THESE INSTRUCTIONS FOR FUTURE REFERENCE

- The ZR Series of recessed troffers is for non-insulated ceiling applications using T-Bar ceiling grid, drywall grid adaptors, and suspended mount.
- Designed for use in 120-277V 50-60 Hz or 347V 60Hz protected circuit (fuse box, circuit breaker). Supply wire sized as per NEC or governing code(s), 90C rated.
- Make sure to cap off all unused leads.
- Dimming leads shall connect only to circuitry identified as a Class 2 Circuit in accordance with the national and local Electrical Wiring Codes.
- ** Not intended for use with 9/16" T-Bar grids unless used with a 9/16" accessory clip like "Armstrong® LFC- Fixture Clip" which can be purchased through distribution. Consult factory for non-standard grid applications.

TO INSTALL:

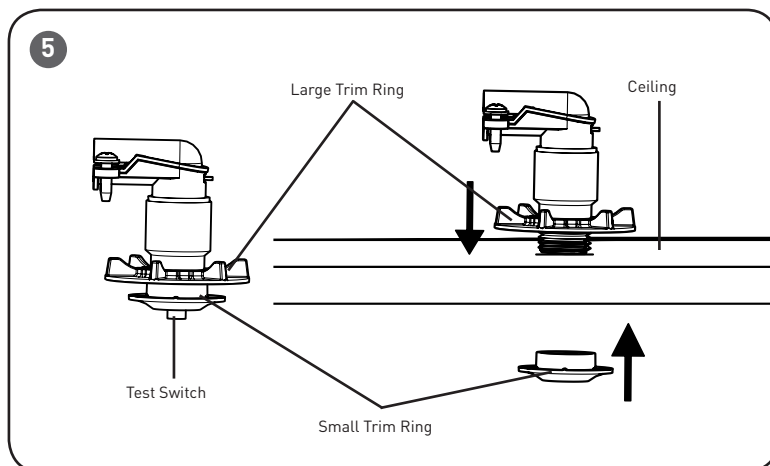
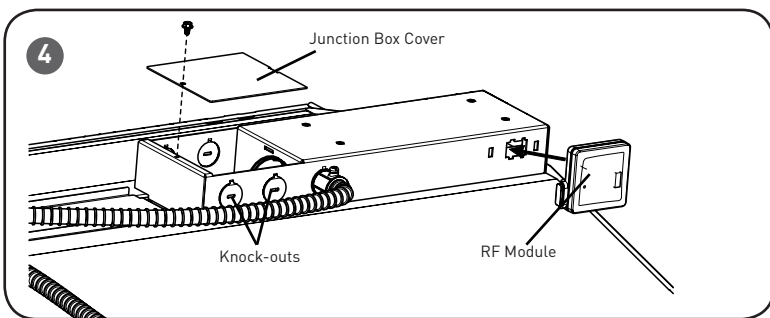
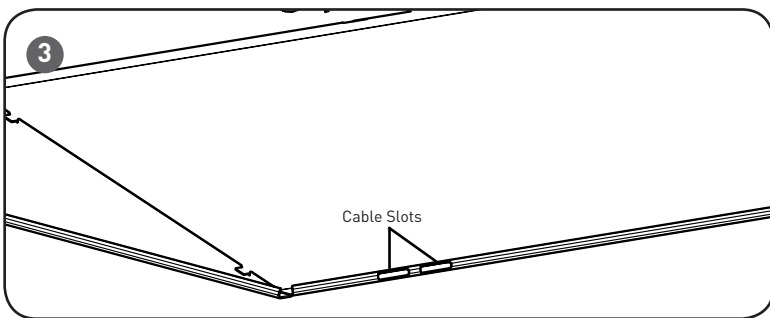
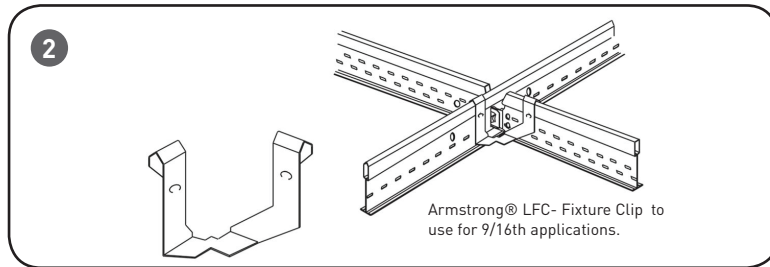
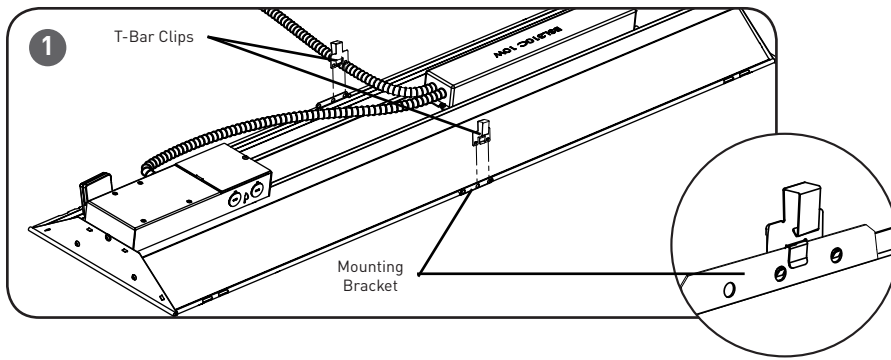

T- BAR CEILING MOUNTING

STEP 1:

Install the (2) supplied T-Bar clips onto the mounting bracket on the outside of the housing. See **Figure 1 and 2.**

STEP 2:

Bring the ZR troffer into the T-Bar Ceiling panel and attach the clips on the housing onto the T-Bar.

STEP 3:

Attach the RF Module to the luminaire by clicking it into place as shown in **Figure 4.**

SUSPENDED MOUNTING

STEP 1:

Attach customer supplied cables to the (2) cable slots on each corner of the housing. See **Figure 3.**

STEP 2:

Attach customer supplied cables to mounting surface using customer supplied hardware. Ensuring that mounting surface can support the luminaire.

STEP 3:

Attach the RF Module to the luminaire by clicking it into place as shown in **Figure 4.**

INSTALLING TEST SWITCH

STEP 1:

Install test switch assembly into ceiling by drilling a 1" hole into the ceiling.

STEP 2:

Unscrew the small trim ring and place test switch assembly through the ceiling. See **Figure 5.**

STEP 3:

Secure the test switch assembly by screwing the small trim ring removed in Step 5 back onto the test switch assembly. Tighten the larger trim ring above the ceiling until it is snugged tight against the ceiling. See **Figure 5.**

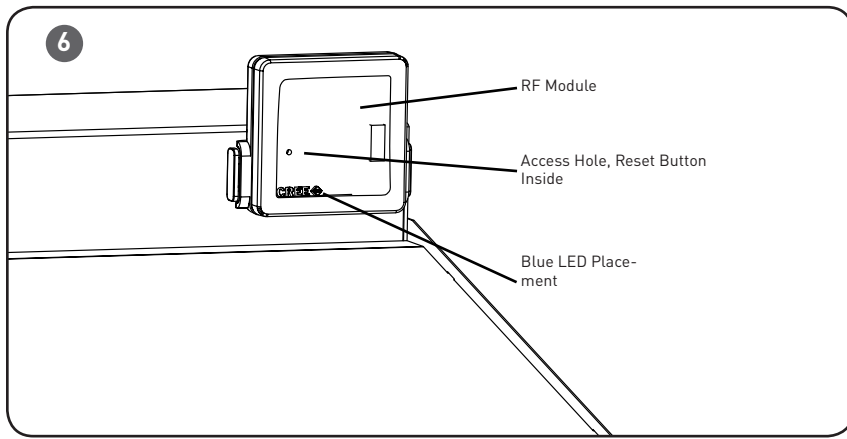

EMERGENCY DRIVER CHECK

NOTE: For short-term testing of the emergency function, the battery must be charged for at least one hour. The emergency driver must be charged for at least 24 hours before conducting a long-term test.

STEP 1:

When AC power is applied, the charging indicator light is illuminated, indicating the battery is being charged. When power fails, the emergency driver automatically switches to emergency power, operating the LED array. When AC power is restored, the emergency driver returns to the charging mode.

STEP 2:

Although no routine maintenance is required to keep the emergency driver functional, it should be checked periodically to ensure that it is working. The following schedule is recommended:

- Visually inspect the charging indicator light monthly. It should be illuminated.
- Test the emergency operation of the fixture at 30-day intervals for a minimum of 30 seconds. When the test switch is depressed, the LED array should operate.
- Conduct a 90-minute discharge test once a year. The LED array should operate for at least 90 minutes.

If the luminaire fails any of these checks, consult service personnel.

REFER ANY SERVICING INDICATED BY THESE CHECKS TO QUALIFIED PERSONNEL. EMERGENCY DRIVER AND AC DRIVER MUST BE FED FROM THE SAME BRANCH CIRCUIT

RESET RF MODULE

NOTE: The Blue LED is located behind the CREE logo on the RF Module. The CREE logo will illuminate blue when the Blue LED is active.

STEP 1:

Actuate RESET button through the access hole. Push and hold until LED on RF module begins blinking rapidly (approximately 6-7 seconds). See **Figure 6**.

STEP 2:

Release for 1 sec.

STEP 3:

Press/Hold RESET button for 0.5 sec. Light will turn off for a few seconds then go to full bright and the Blue LED on the RF Module should begin a 2 blink sequence. **Figure 6**.

TROUBLESHOOTING:

Out of the box, if the light does not turn on when power is applied:

- Check Wiring with power off
- If wired correctly, check to see if Blue LED blinking on the RF Module.
- If Blue LED is blinking, then perform a RESET [See RESET RF MODULE section].
- If Blue LED is on solid or off, call Cree Customer Service.
- If you have done a RESET, and the light is still off, call Cree Customer Service.

If light is unresponsive, use Cree Configuration Tool to verify configuration.

FCC NOTICE

RF Exposure Notice

To comply with the FCC/IC RF exposure compliance requirements, this device and its antenna must not be co-located or operating to conjunction with any other antenna or transmitter.

This equipment should be installed and operated with minimum distance 5cm between the radiator & your body. No other antenna is authorized for use with this product.

FCC COMPLIANCE STATEMENT

CAUTION: Changes or modifications not expressly approved could void your authority to use this equipment.

This device complies with part 15 of the FCC Rules. Operation is subject to the following two conditions: (1) This device may not cause harmful interference, and (2) this device must accept any interference received, including interference that may cause undesired operation.

Note: This equipment has been tested and found to comply with the limits for a Class A digital device, pursuant to part 15 of the FCC Rules. These limits are designed to provide reasonable protection against harmful interference when the equipment is operated in a commercial environment. This equipment generates, uses, and can radiate radio frequency energy and, if not installed and used in accordance with the instruction manual, may cause harmful interference to radio communications. Operation of this equipment in a residential area is likely to cause harmful interference in which case the user will be required to correct the interference at his own expense. CAN ICES-003 (A)/NMB-003 (A)

The LED in the front of this device operates within Risk Group 1 levels per IEC 62471.

INDUSTRY CANADA STATEMENT

This device complies with Industry Canada licence-exempt RSS standard(s). Operation is subject to the following two conditions: (1) this device may not cause interference, and (2) this device must accept any interference, including interference that may cause undesired operation of the device. In addition, this device complies with ICES-001 of the Industry Canada (IC) Regulations.

Le présent appareil est conforme aux CNR d'Industrie Canada applicables aux appareils radio exempts de licence. L'exploitation est autorisée aux deux conditions suivantes : (1) l'appareil ne doit pas produire de brouillage, et (2) l'utilisateur de l'appareil doit accepter tout brouillage radioélectrique subi, même si le brouillage est susceptible d'en compromettre le fonctionnement.

ELECTRICAL CONNECTIONS

NOTE: The emergency driver must be fed from the same branch as the AC Driver.

STEP 1:

Remove the cover of the junction box and bring in appropriate power supply to the junction box using one of the knock-outs. See **Figure 3**.

STEP 2:

Using customer supplied 90°C minimum rated wire connectors, make the following electrical connections:

- Connect the black luminaire lead to the unswitched voltage supply lead.
- Connect the white/red luminaire lead to the switched supply switched.
- Connect white luminaire lead to the neutral supply lead.
- Connect ground bare or green/yellow wire lead to the supply ground lead.

STEP 3:

Locate the two red leads in the junction box and connect them using customer supplied connector.

STEP 4:

Push all leads into the junction box. Reattach junction box cover that was removed in Step 1, make sure no wires are pinched.

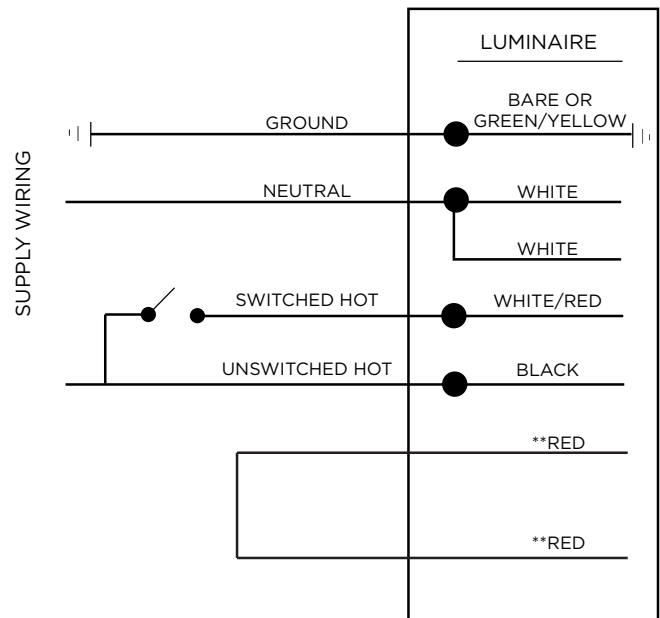

**** NOTE: DO NOT mate leads until installation is complete and AC power is supplied**