

Raychem RayClic Connection System

RAYCLIC-LE LIGHTED END SEAL KIT INSTALLATION INSTRUCTIONS

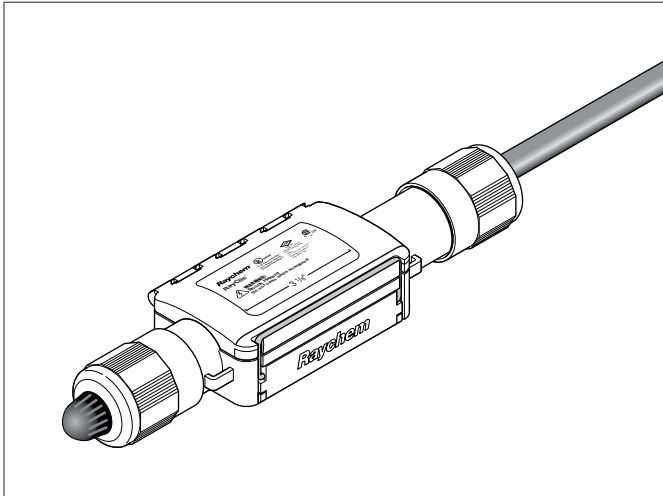

DESCRIPTION

The RayClic-LE Lighted End Seal Kit is for use with Raychem IceStop, XL-Trace and HWAT heating cables. The connection is designed to be installed above the pipe insulation or mounted on the wall at the end of the heating cable circuit. These installation instructions should be used in conjunction with the IceStop, XL-Trace and HWAT System Installation and Operation Manuals.

For technical support contact your Pentair Thermal Management representative or call Pentair Thermal Management (800) 545-6258.

TOOLS REQUIRED

- Utility knife
- Wire cutters
- TORX® T20 screw driver

OPTIONAL ACCESSORIES (Not included in this kit):

- RayClic-SB-02 Wall mounting bracket

APPROVALS



718K Pipe Heating Cable
877Z De-Icing and Snow Melting
Not UL Listed with XL-Trace heating cable for buried piping.



For HWAT, IceStop, and XL-Trace only
Hazardous Locations: For IceStop (GM-XT) only
Class I, Div. 2, Groups A,B,C,D

KIT CONTENTS

Item	Qty	Description
A	1	Lighted end seal
B	1	Pipe mounting bracket
C	2	Plastic cable ties
D	1	Clip
E	1	Cable lubricant

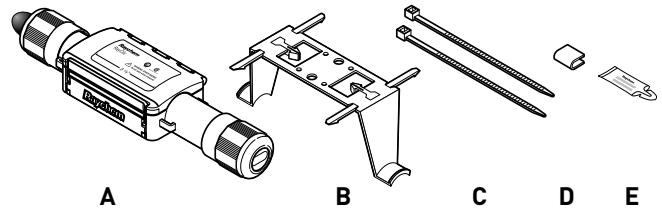

⚠ WARNING:

This component is an electrical device that must be installed correctly to ensure proper operation and to prevent shock or fire. Read these important warnings and carefully follow all the installation instructions.

- To minimize the danger of fire from sustained electrical arcing if the heating cable is damaged or improperly installed, and to comply with the requirements of Pentair Thermal Management, agency certifications, and national electrical codes, ground-

fault equipment protection must be used. Arcing may not be stopped by conventional circuit breakers.

- Bus wires will short if they contact each other. Keep bus wires separated.
- Keep components and heating cable ends dry before and during installation.

- The black heating cable core is conductive and can short. It must be properly insulated and kept dry.
- Component approvals and performance are based on the use of Pentair Thermal Management-specified parts only. Do not use substitute parts or vinyl electrical tape.
- Leave these instructions with end user for reference and future use.

If you experience difficulty during installation, refer to the "Troubleshooting Guide" on page 5.

Lighted End Seal Installation

1

- Using the plastic cable ties, attach the bracket to the pipe.
- Note:** For roof-mounted applications, follow steps 3 through 9 (pages 2-4), then turn to "Roof Installation" on page 4.
- Do not install the end seal where it can be immersed in water.**

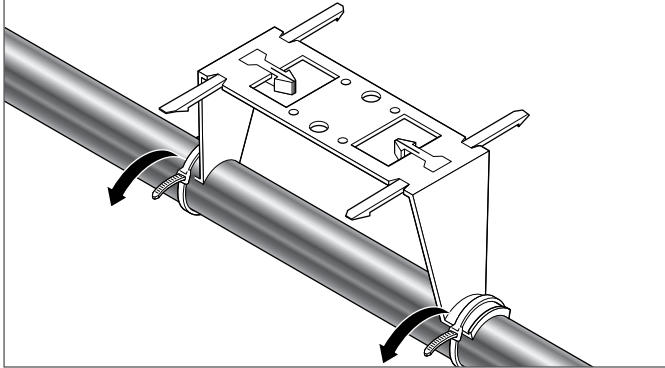

2

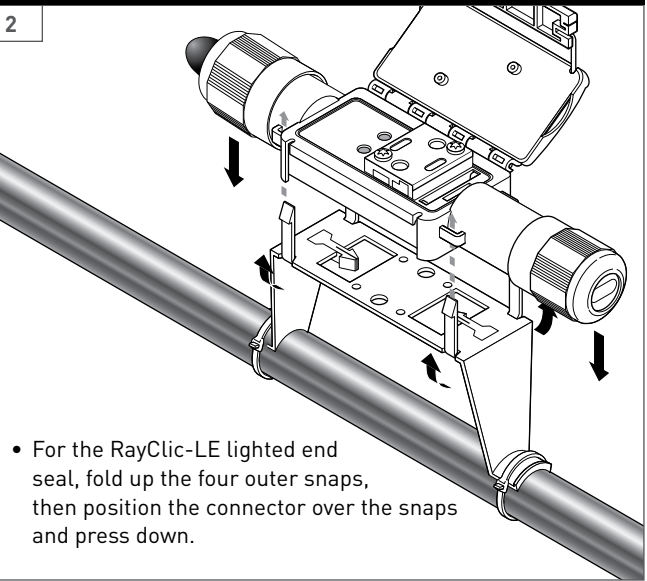

- For the RayClic-LE lighted end seal, fold up the four outer snaps, then position the connector over the snaps and press down.

3

- Allow enough extra heating cable to make service loops as required.
- Make sure end of heating cable is cut clean.

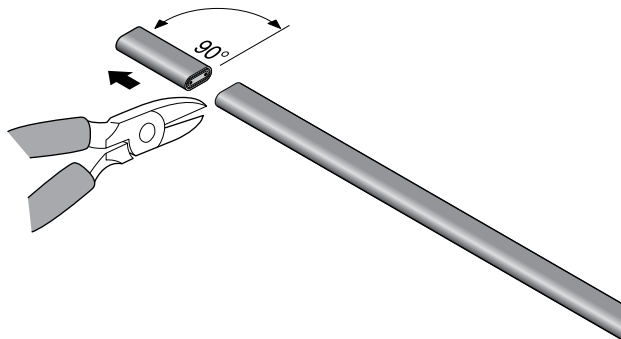

4

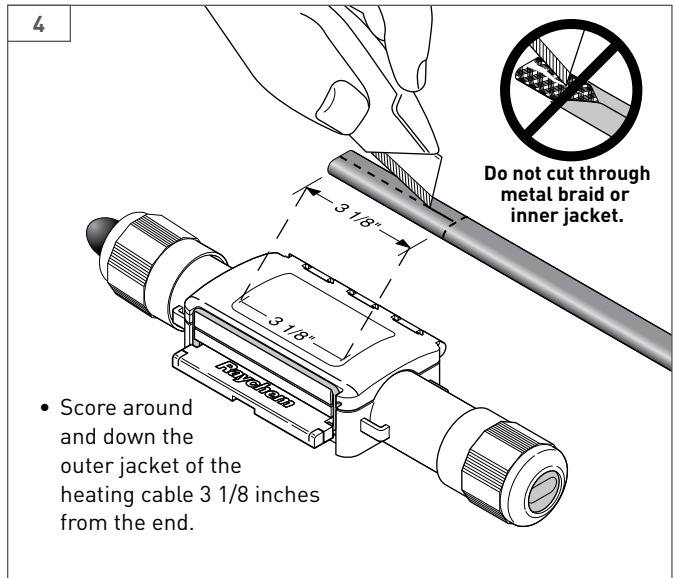

- Score around and down the outer jacket of the heating cable 3 1/8 inches from the end.

5

- Remove the outer jacket.
- Place metal clip over the base of exposed braid.

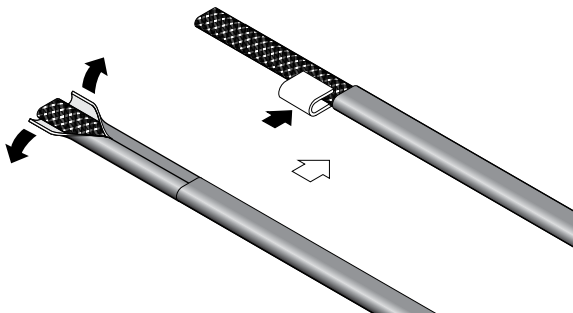

HWAT

6A

HWAT Only

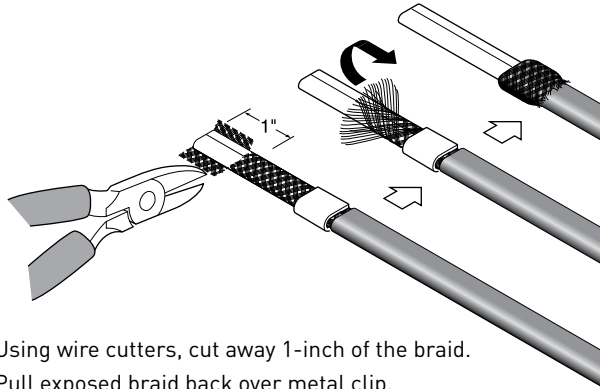

- Using wire cutters, cut away 1-inch of the braid.
- Pull exposed braid back over metal clip.

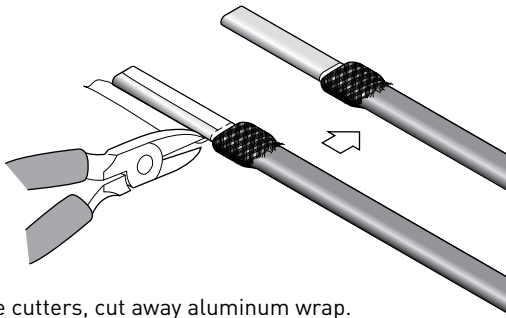

- Using wire cutters, cut away aluminum wrap.

IceStop and XL-Trace

6B

IceStop and XL-Trace Only

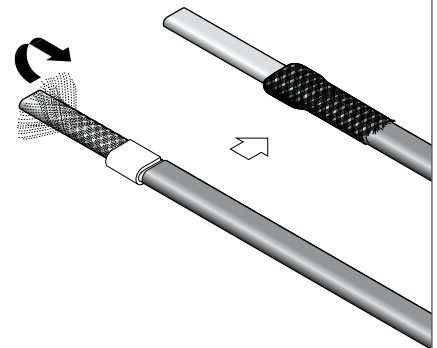

- Pull exposed braid back over metal clip.

7

- Apply a small amount of lubricant to the jacket surface near the end of the cable.
- Avoid using large amounts of lubricant on the exposed end of the cable.

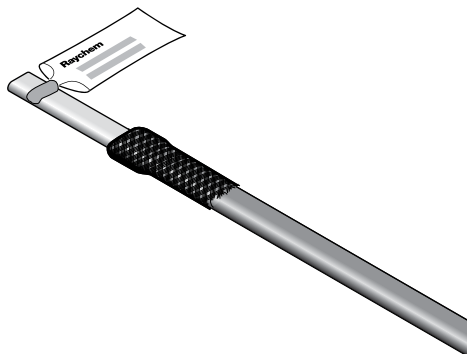

8

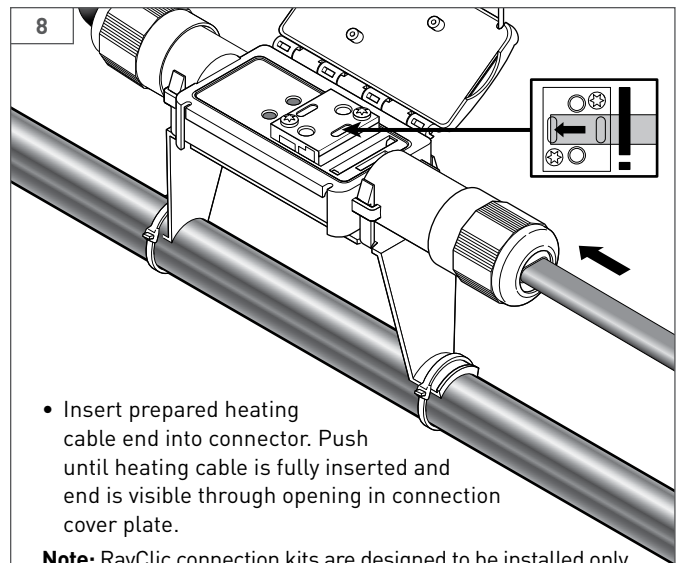

- Insert prepared heating cable end into connector. Push until heating cable is fully inserted and end is visible through opening in connection cover plate.

Note: RayClic connection kits are designed to be installed only once; the heating cable cannot be removed once installed

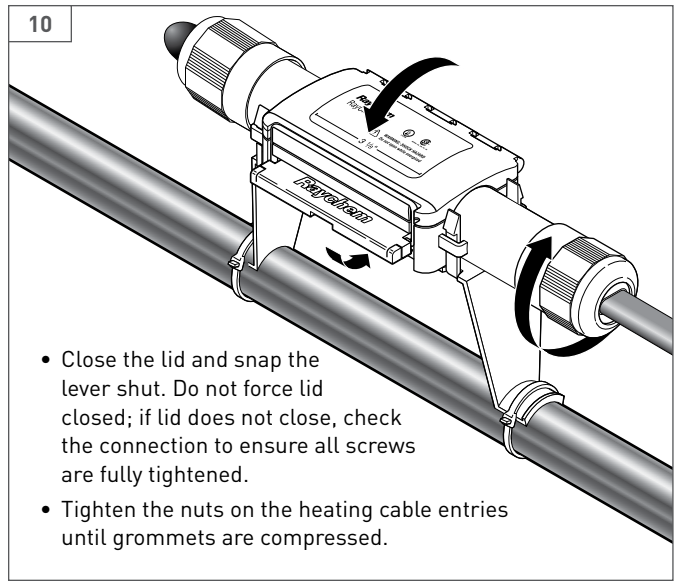
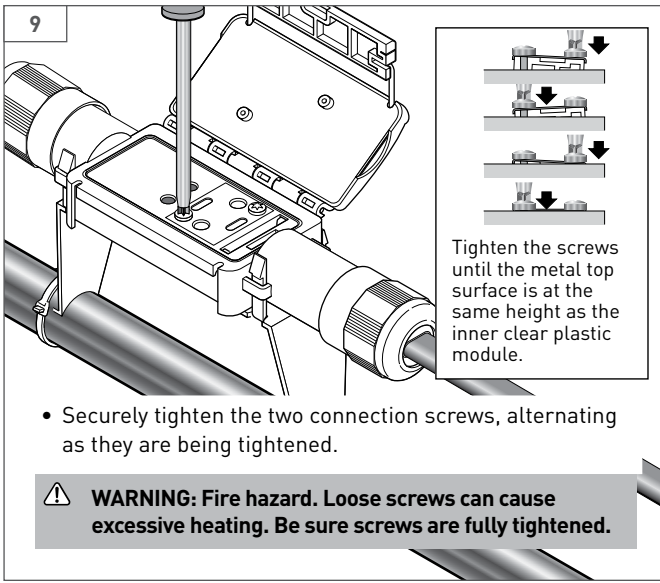

Roof Installation

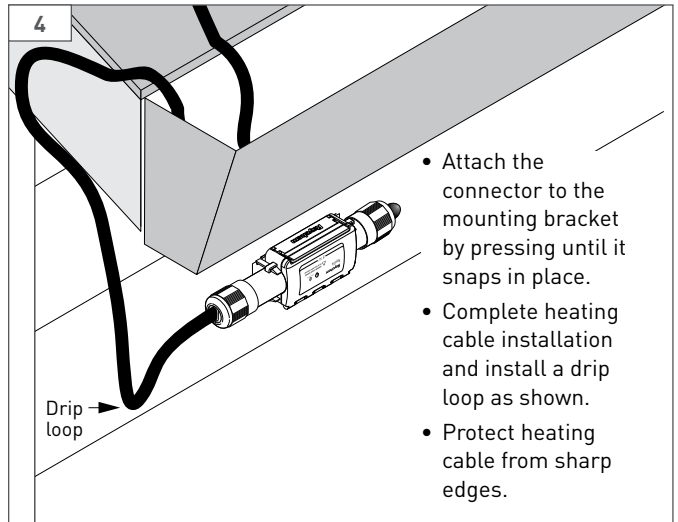
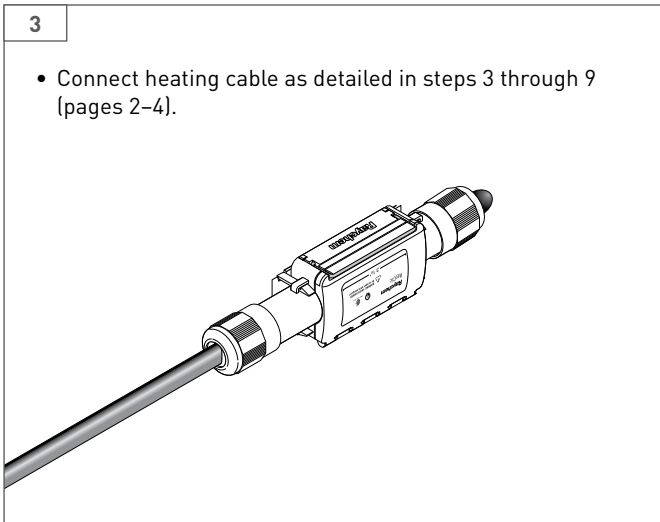
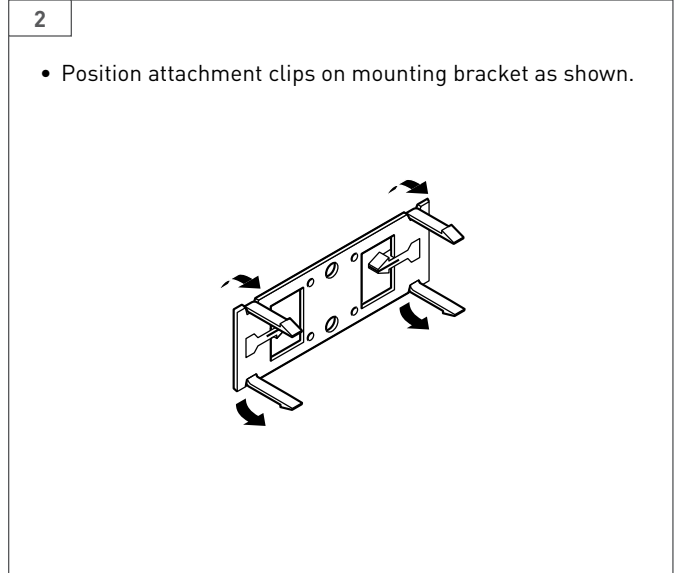
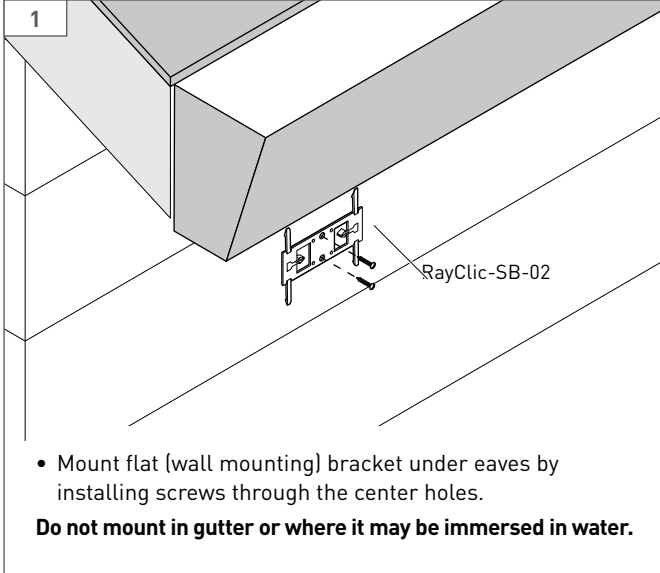

Troubleshooting Guide

Problem	Solution
Braid clips are missing.	The braid clips are attached to the cardboard packing insert under the lid. The braid clips must be used to ensure a ground connection. If clips are missing or lost, call Pentair Thermal Management at (800) 545-6258.
Mounting bracket is missing.	A pipe mounting bracket is supplied with the Power Connection, Powered Splice, Powered Tee and Lighted End Seal kits. A wall mounting bracket or additional pipe mounting bracket may be ordered using one of the catalog numbers listed under "Optional Accessories" on the front page of these instructions when you place your order.
Connector does not snap onto bracket.	The bracket has two sets of attachment clips. Fold up the four outer clips for the Power Connection and Lighted End Seal kit. Fold up only the center clips for the Powered Splice and Powered Tee kits.
Heating cable type not mentioned.	RayClic connection kits are approved for use only with Raychem HWAT, XL-Trace, and IceStop heating cables. Do not use with other heating cables.
Braid clip does not fit.	Be sure the clip is installed on the metal braid, not on the outer jacket.
Heating cable does not have aluminum wrap.	Only HWAT heating cables have the aluminum wrap under the braid. Skip the aluminum wrap removal step for XL-Trace and IceStop heating cables.
Heating cable cannot be inserted into connector.	Check for the following: <ul style="list-style-type: none"> • Apply lubricant to heating cable primary (white) jacket. • Outer jacket strip length is 3 1/8-inches. • Braid clip is installed on top of the metal braid, not on the outer jacket. • Braid is pulled back over braid clip. • For HWAT, 1-inch of braid is removed. • Sealing nut is loose (but not removed). • Connection screws are loose.
Lid does not close.	Be sure all screws are fully tightened before closing the lid.
Heating cable cannot be removed.	The power connection and end seal are designed to be installed only once; the heating cable cannot be removed once installed. Additional RayClic-E and RayClic-LE end seals can be ordered from Pentair Thermal Management.
Light does not come on.	<ul style="list-style-type: none"> • Verify there is voltage present. • Verify the cable guide is screwed down completely. • If the light still does not function, the RayClic-LE cannot be repaired and must be replaced.

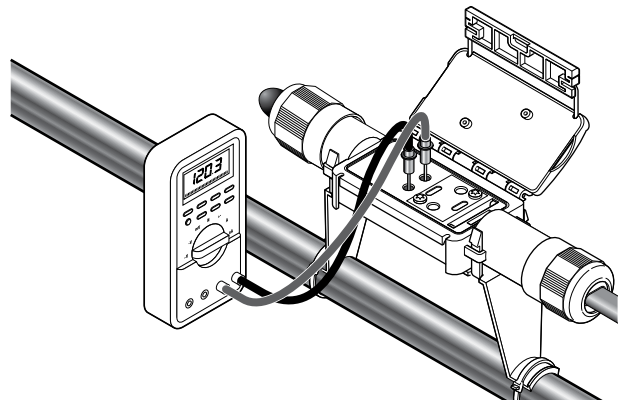



WWW.THERMAL.PENTAIR.COM

NORTH AMERICA

Tel: +1.800.545.6258
Fax: +1.800.527.5703
Tel: +1.650.216.1526
Fax: +1.650.474.7711
thermal.info@pentair.com

EUROPE, MIDDLE EAST, AFRICA

Tel: +32.16.213.511
Fax: +32.16.213.603
thermal.info@pentair.com

ASIA PACIFIC

Tel: +86.21.2412.1688
Fax: +86.21.5426.2917
cn.thermal.info@pentair.com

LATIN AMERICA

Tel: +55.11.2588.1400
Fax: +55.11.2588.1410
thermal.info@pentair.com

Pentair, HWAT, IceStop, RayClic, and XL-Trace are owned by Pentair or its global affiliates. All other trademarks are the property of their respective owners. Pentair reserves the right to change specifications without prior notice.