

MODEL EPC-1-D

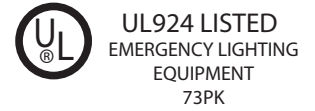

**Emergency Power Dimmer Control With Automatic Diagnostic and Manual Test Features
FOR 4 WIRE DIMMABLE LOADS (0-10V and Low Voltage Digital Dimming)**

Save maximum energy through dimming & still meet safety codes during power failure

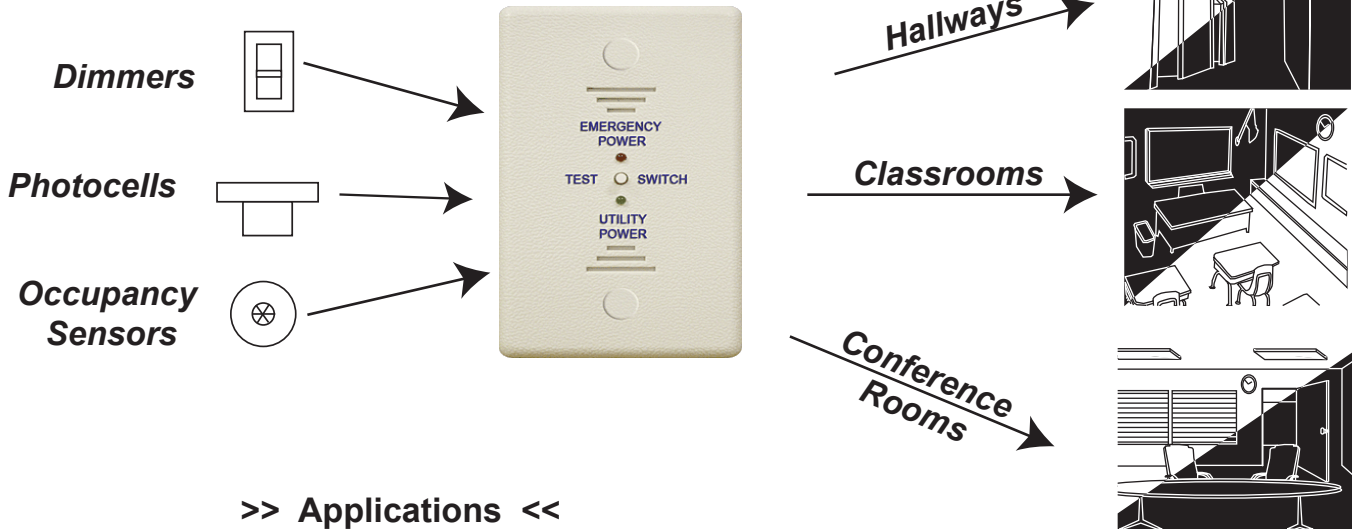

>> Applications <<

Model EPC-1-D allows switching & dimming of designated emergency luminaires during normal operation & automatically brings emergency luminaires to full brightness during a utility power interruption.

- 0-10V Dimming Controls
- Low Voltage Digital Dimming Systems including DALI, and others.

Active 0-10V / Digital Override Universal Compatibility

Actively drives emergency loads to full bright during power interruption and testing, ensuring compliance with code and compatibility with all controls and loads without the need for an additional 20A branch transfer switch.

Patented Automatic Diagnostic Exclusive Feature

2.5 second automatic diagnostic checks emergency source, EPC-1-D, ballast, & lamp(s).

Eliminates manual monthly testing and is approved for this purpose.

Integral Test Switch & LED Status Indicators

Integral test switch for easy initial footcandle verification

Power indicator LED's verify wiring & simplify troubleshooting

Power Supervision Redundancy

Emergency luminaire and red supervision LED will not illuminate if emergency supply is disconnected during normal operation

Provides Immediately Visible warnings

EPC Emergency Power Controls are tested, approved, and listed by Underwriters Laboratories under UL 924 standards for designated emergency light fixture controls. They meet and exceed all pertinent code requirements from NEC, NFPA, OSHA, and life safety codes, in addition to major local codes.

All model EPC-1-D units are tested during production and burned in upon completion.

3 YEAR LIMITED WARRANTY

Model EPC-1-D Typical Wiring

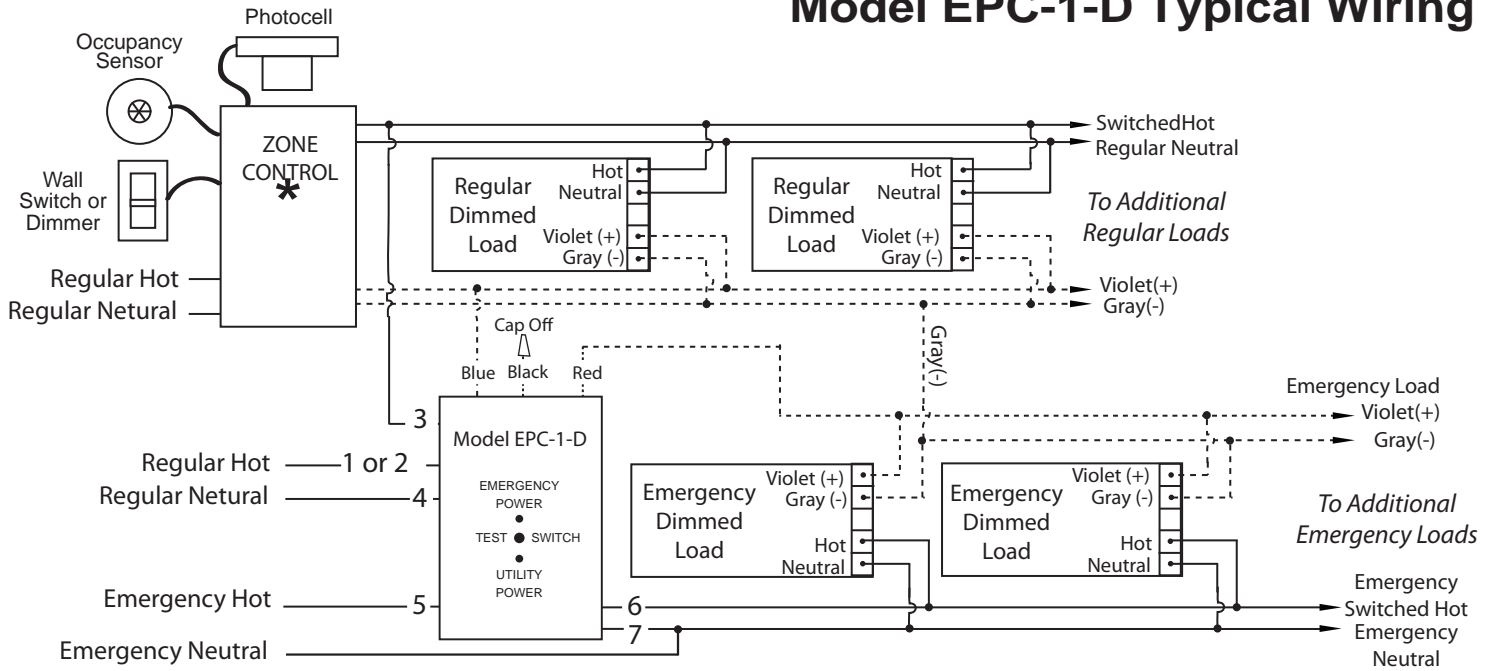

REGULAR POWER WIRING		
Wire #	Color	Connection
1	Black	Regular Hot (120V)
2	Orange	Regular Hot (277V)
3	Red	Switched Hot
4	White	Regular Neutral

EMERGENCY POWER WIRING		
Wire #	Color	Connection
5	Blue	Emergency Hot
6	Yellow	Emergency Load Hot
7	White/Blue Stripe	Emergency Neutral

PLENUM CABLE B LOW VOLTAGE WIRING	
Blue	Dimmer Violet(+)
Red	Emergency Load Violet(+)
Black	Cap Off

- * NOTE: Zone Control device can be any combination of the following:
- Intelligent zone controller including both low voltage dimming output & line voltage switching output.
 - Line voltage switching devices (such as occupancy sensor contact, time clock, relay panel) & low voltage dimming devices including photocells, wall dimmers, & other low voltage dimming signals (0-10V or digital).

See p.4 for alternate wiring diagrams and frequently asked questions

Theory of Operation

- Normal Operation:** The zone control device turns on and off both regular and emergency luminaires simultaneously. The zone dimmer control dims regular and emergency luminaires simultaneously. Switched and dimmed control of emergency luminaires is accomplished through **Emergency Power Dimmer Control, EPC-1-D**.
- Emergency Operation:** Wire input #1 or #2 and neutral are connected internally to a utility power sensing circuit. During a utility power interruption, the **EPC-1-D** energizes wire #6, which switches on emergency load(s) regardless of switch position. Additionally, the low voltage dimming circuit is disconnected from the emergency load(s), which are then brought to full brightness (100%), regardless of dimmer position.
- Automatic Diagnostic & Testing Operation:** When the zone control is turned off, such as at the end of the day, the emergency luminaires stay on at full brightness for 2.5 seconds & indicate that an emergency power source was available & that the EPC-1-D, ballast, & lamp(s) are all functioning correctly. This satisfies the monthly test requirement required by law. When extended duration testing is desired, such as during initial start-up foot candle readings, the manual test button can be pressed.
- Emergency Power Clarification:** Emergency Line power is supplied at all times from a 24 hour emergency power panel. During normal time this panel is supplied with utility power. During a utility power failure, it is supplied with generator or equivalent power.

Electrical Specifications

Dual Voltage: 120V/277V Sensing Input ,
 120V/277V Load
 20 Amp Ballast Load Rating
 1800W Incandescent Load Rating at 120V
 1500W Incandescent Load Rating at 277V
 Voltage Surge Protection
 UL924 Listed

Mechanical Specifications

Shipping Weight: 8 oz | Color : White
 Temperature: 32°F - 140°F
 Flush Mounted Size: 4-3/4" x 2-3/4" x 1/4"
 Body Size: 2-7/8" x 1-3/4" x 1-3/4"
 UL94-5VA Rating: Safe for installation
 above the suspended ceiling.

Mounting

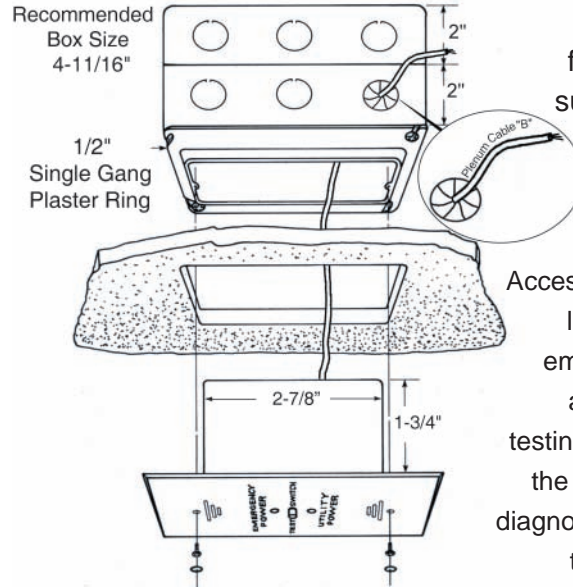

Can be mounted flush or above the suspended ceiling *

Accessibility requirements limit the mounting of emergency controls to accessible areas for testing reasons, however the EPC-1-D automatic diagnostic exempts it from these requirements.

Initial Testing, Troubleshooting & Maintenance of EPC-1-D

In a new installation, where 10 or 100 separate devices may be used, each having as many as 14 wires to be correctly connected, it is important that a fast convenient method is used to check the connections. In order to test that the wires are connected correctly, without any inconvenience to other occupants, do not turn off regular utility supplied power or turn on the emergency generator until you have checked each EPC-1-D device and light fixtures using the following methods.

When room switch is on & dimmer is at full-bright setting, emergency & regular fixtures should be illuminated at full-bright.

- 1) To test normal operation, ensure branch circuit breaker is connected and utility power is available. If green LED is not illuminated, confirm wiring connections and continuity to branch panels.
- 2) To test emergency operation, ensure emergency source is connected and red LED is illuminated. Turn room switch to "OFF" position, and ensure that emergency lights stay illuminated for at least 2.5 seconds. If emergency lights do not stay on for at least 2.5 seconds, confirm wiring connections and continuity to emergency panel and emergency power source.

No maintenance is required to keep the EPC-1-D functional. However, regular testing should be performed when the lamps or ballasts have been replaced or when facility remodeling has taken place.

Single Line Drawings

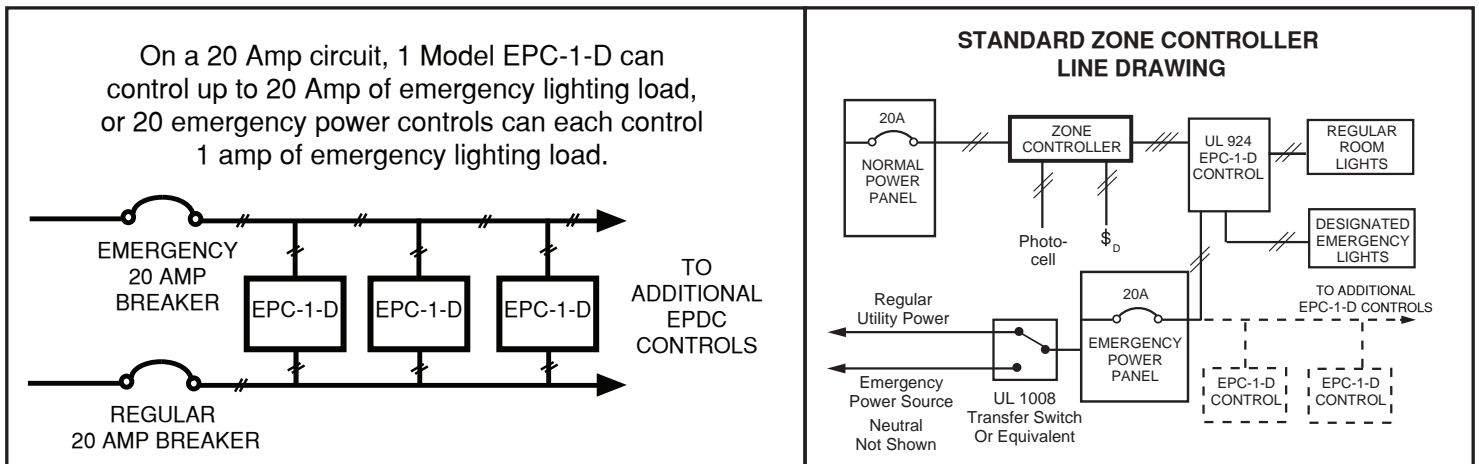

Frequently Asked Questions

Question: What if there is only 1 light fixture in the room? What if all light fixtures are emergency fixtures?
Answer: Follow the standard wiring diagram on p.2. Treat the fixture(s) as “emergency dimmed loads” & follow standard wiring diagram on p.2. “Regular dimmed load” is not used in this application.

Question: What if using a digital low voltage dimmer control & ballasts, such as DALI protocol?
Answer: Follow the standard wiring diagram on p.2. Violet and Gray leads will be designated as “D1,D2” or equivalent for digital low voltage signal. If no line voltage switch is used, see Alternate Wiring C, below.

Special Applications/Alternate Wiring for EPC-1-D

The wide range of 0-10V controls and loads available has led to a number of different requirements and standards. The EPC-1-D is designed to accommodate many alternate or special applications, and to ensure proper operation for all ballast or controller manufacturers. If the application required is not listed below, contact LVS, Inc. at 1-800-982-4587 for a custom wiring diagram.

(A) When grounding of the low voltage input of a ballast is required during emergency operation:
 Use Alternate Diagram “A.” Plenum Cable B Black to ground, all line voltage leads are identical.

(B) When a minimum resistive load is required on the low voltage input of a ballast during emergency operation:
 Use Alternate Diagram “B.” Connect a resistor (minimum resistance 75KΩ) between Plenum Cable B black lead and gray input of emergency ballasts, all line voltage leads are identical.

(C) When using a digital low voltage dimmer control with no line voltage switching:
 Use Alternate Diagram “C.” Please note that for this application the automatic diagnostic feature does not function, therefore manual monthly testing is required by NEC.

Alternate Wiring Diagram “A”

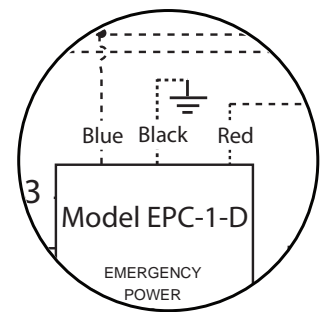

Alternate Wiring Diagram “B”

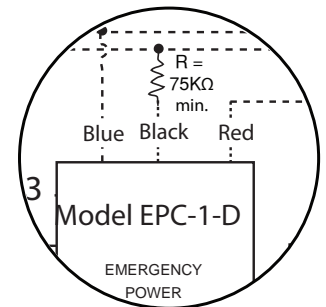

Alternate Wiring Diagram “C”

