

GE
Lighting

Retrofit Installation Guide

IMMERSION™

LED Refrigerated Display Lighting

Vertical Cases
RV60 Series

Center Mullion Lights

30-inch: GELT603050CTR-SY (206432)

48-inch: GELT604850CTR-SY/-SB (85742/85745), GELT604840CTR-SY/-SB (85748/85751), GELT604835CTR-SY/-SB (85754/85757)

60-inch: GELT606050CTR-SY/-SB (85699/85702), GELT606040CTR-SY/-SB (85705/85708), GELT606035CTR-SY/-SB (85711/85714)

67-inch: GELT606750CTR-SY/-SB (85717/85722), GELT606740CTR-SY/-SB (85725/85728), GELT606735CTR-SY/-SB (85736/85739)

Description Code (Single Unit Product Number/10-Pack Product Number)

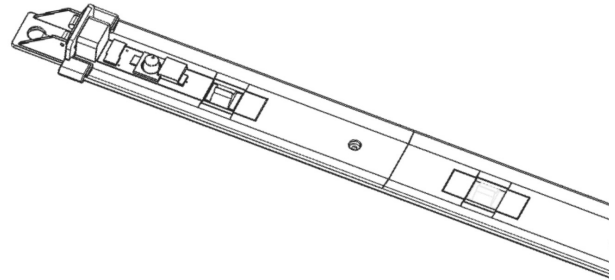

BEFORE YOU BEGIN

Read these instructions completely and carefully.

FOR YOUR SAFETY

Read and observe all **CAUTIONS** and **WARNINGS** shown throughout these instructions.

- Installation to be performed by factory trained service personnel only.
- For use inside a commercial refrigeration case with packaged foods only.
- Use this unit only in the manner intended by the manufacturer. If you have any questions, contact the manufacturer.
- Before installing, servicing or cleaning unit, switch power off at the service panel and follow appropriate lock out/tag out safety procedures

LED DRIVER COMPATIBILITY

This system is compatible with **GEPS6100NCCON-SY**, **GEPS6500NCMUL-SY**, **GELP24-100U-GL**, or **GELP24-60U-GL** LED Drivers. Please refer to the separate LED driver installation guide for appropriate wiring connections.

This device complies with part 15 of the FCC Rules. Operation is subject to the following two conditions: (1) This device may not cause harmful interference, and (2) this device must accept any interference received, including interference that may cause undesired operation.

NOTE: This equipment has been tested and found to comply with the limits for a Class A digital device, pursuant to part 15 of the FCC Rules. These limits are designed to provide reasonable protection against harmful interference when the equipment is operated in a commercial environment. This equipment generates, uses, and can radiate radio frequency energy and, if not installed and used in accordance with the instruction manual, may cause harmful interference to radio communications. Operation of this equipment in a residential area is likely to cause harmful interference in which case the user will be required to correct the interference at his own expense.



imagination at work

PREPARE ELECTRICAL WIRING

Electrical Requirements



- The power supply must be supplied with 100-240 VAC, 50/60 Hz, and connected to an individual properly grounded branch circuit, protected by a 15 or 20 ampere circuit breaker or time delay fuse.
- Wiring must be 2 wire with ground and rated for 75°C (167°F).
- Do not overload driver, follow installation instructions for the GEPS6100NCCON-SY, GEPS6500NCMUL-SY, GELP24-100U-GL, or GELP24-60U-GL.
- Ensure that all connection points are sealed for damp location using the appropriate method per the NEC or local electrical code.



Grounding Instructions—Cable Direct

- This lighting system must be connected to a grounded metal, permanent wiring system, or an equipment grounding conductor must be run with the circuit conductors and be connected to the equipment grounding terminal.

⚠ CAUTION/ATTENTION

Risk of injury. While performing installations described, gloves, safety glasses or goggles should be worn. / **Risque de blessure.** Lors de l'exécution des installations décrites, des gants, des lunettes de sécurité ou des lunettes de protection doivent être portées.

⚠ WARNING/AVERTISSEMENT

Risk of electrical shock. Disconnect power before servicing or installing product. LED Retrofit Kit Installation requires knowledge of luminaires electrical systems. If not qualified, do not attempt installation. Contact a qualified electrician. Install this kit only in the luminaires that have the construction features and dimensions shown in the photographs and/or drawings. / **Risque de choc électrique.** Couper le courant avant de réparer ou installer le produit. LED Retrofit Kit d'installation nécessite la connaissance des systèmes luminaires électriques. Si vous n'êtes pas qualifié, ne tentez pas l'installation. Contactez un électricien qualifié. Installez ce kit seulement dans les luminaires qui ont les caractéristiques de construction et les dimensions figurant sur les photographies et / ou des dessins.

1 Remove Existing Lighting Components

Tools Required

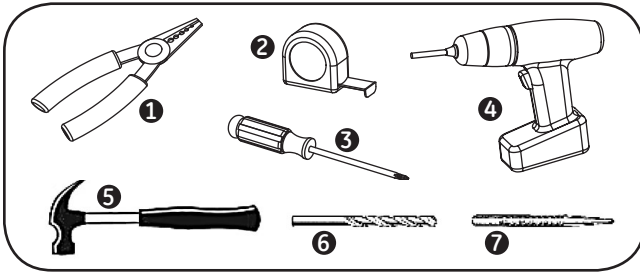

- 1 Wire stripper/cutter
- 2 Tape measure
- 3 Screwdriver
- 4 Cordless drill
- 5 Hammer
- 6 7/64-inch (2.8mm) drill bit
- 7 Center punch

Components Required

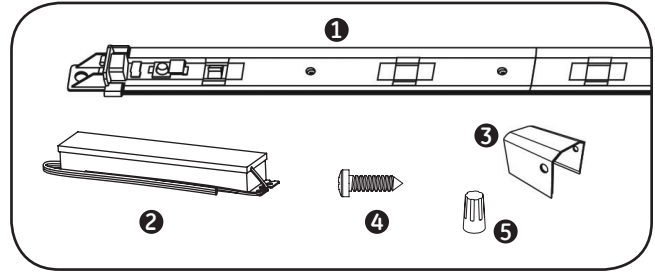

- 1 LED light
- 2 LED driver
- 3 Wire cover
- 4 6-32 x 1/2" screws
- 5 Twist lock splice wire connectors

- For retrofit only. If you are an OEM, please refer to the OEM Installation Guide.
- Refer to manufacturing manual for refrigeration case to identify lighting control circuits. Ensure that power is switched off at the service panel for the lighting circuit. If a lighting power switch is not provided in the refrigeration case, power removal can be performed at the main breaker panel.
- Locate existing lighting components including ballasts, lampholders, lamps, and lampguards in the refrigeration case for removal. Please refer to refrigeration manual for any questions dealing with component locations.
- Remove lamps, lampholder and lamp guards. Cut the wiring, making the cut as close to the lampholder as possible. Do not remove wiring from case as it will be utilized to attach the LED light. Dispose of components per federal and local regulations.
- Locate ballast within system. The most common location is in the mullion or the electrical raceway found in the bottom of the refrigerated case.
- Disconnect ballast input and output connectors. Cut the ballast connector wires nearest to the connector and remove connector. Unscrew the mounting screws that attach ballast and remove ballast. Dispose of ballasts according to federal and local regulations. LED driver installation will begin at Step 5 and Step 6.
- To install the LED light, first identify the wiring for connection to the LED driver. After removing the connector from ballast, leave the existing ballast input and output wires for reconnection in a later step.

Fluorescent Component Location

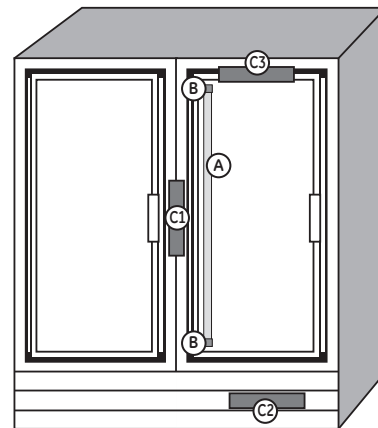

- A Lamp with lamp guards (behind mullion)
- B Lamp holders
- C Ballast
 - 1. Mullion
 - 2. Raceway
 - 3. Overhead door frame

⚠ WARNING/AVERTISSEMENT

Risk of fire or electric shock. Luminaire wiring and electrical parts may be damaged when drilling for installation of LED retrofit kit. Check for enclosed wiring and components. / **Risque de feu ou électrocution.** Les pièces et câbles électriques risquent d'être endommagés lors du perçage des trous pour l'installation du luminaire à DEL. Veuillez vérifier si des câbles et composants se trouvent derrière la paroi avant de percer.

To prevent wiring damage or abrasion, do not expose wiring to edges of sheet metal or other sharp objects. / Pour éviter l'endommagement de câblage ou l'abrasion, ne pas exposer le câblage aux bords de feuilles de métal ou d'autres objets tranchants.

2 Prepare for Installation of Center LED Lights

- Measure the total width of the mullion, and mark a vertical line half the total width near the top and bottom of the mullion.
- Prepare for the upper end of the Center LED Light. Mark a horizontal line a minimum 2 1/8-inches (54 mm) from the top of the mullion, and another horizontal line 3/8-inch (10 mm) below this line.
- Prepare for the lower end of the Center LED Light.
 - For 30-inch LED Lights, mark a horizontal line 27 1/32" (687mm) beneath the first line drawn for the top Mounting Tab.
 - For 48-inch LED Lights mark a horizontal line 46 1/4" (1175mm) beneath the first line drawn for the top Mounting Tab.
 - For 60-inch LED Lights mark a horizontal line 58 3/32" (1476mm) beneath the first line drawn for the top Mounting Tab.
 - For 67-inch LED Lights, mark a horizontal line 65 15/32" (1663mm) beneath the first line drawn for the top Mounting Tab.
- Center the center punch directly at the intersection of the horizontal lines and the vertical line (top and bottom) and establish a dimple.
- Use power drill and 7/64-inch (2.8 mm) drill bit to drill holes at the intersection of the vertical and horizontal center line.

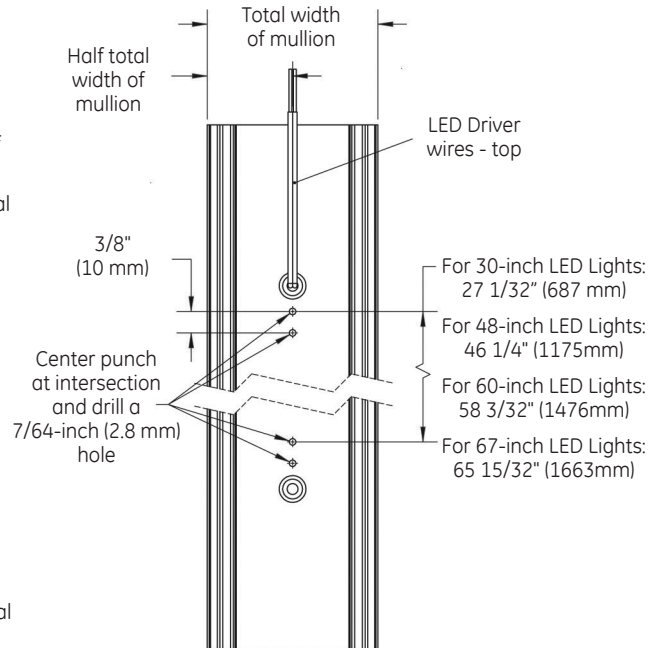

⚠ WARNING/AVERTISSEMENT

Risk of electrical shock. Only those open holes indicated in the photographs and/or drawings may be made or altered as a result of kit installation. Do not leave any other open holes in an enclosure of wiring or electric components / **Risque de choc électrique.** Seuls les trous ouverts indiqués dans les photos et / ou les dessins peuvent être faites ou modifiés à la suite du montage du kit. Ne pas laisser autres trous ouverts dans l'enceinte du câblage électrique ou composants.

3 Install Center LED Lights

- Place a Center LED Light against the back face of the mullion near the two holes drilled at the top.
- Insert a #6-32 x 1/2-inch sheet metal screw into the top slot of the Mounting Tab on the Center LED Light and into the first hole that was drilled in the center mullion.
- Use a screwdriver to thread the screw into the drilled hole.
- Repeat for the second screw, and for the lower end of the Center LED Light.
- Refer to the manufacturing manual for door frame to ensure there are no components contained inside the mullion that could be drilled through. Use a #6 - 3/4-inch self-drilling screw to attach the Center LED Light into one or two of the additional mounting holes located near the center of the LED Light.
- Refer to wiring diagram on page 5. Connect the red and black output wires from the LED Light to the red and black wires on the LED Driver using the twist lock splice wire connectors provided.

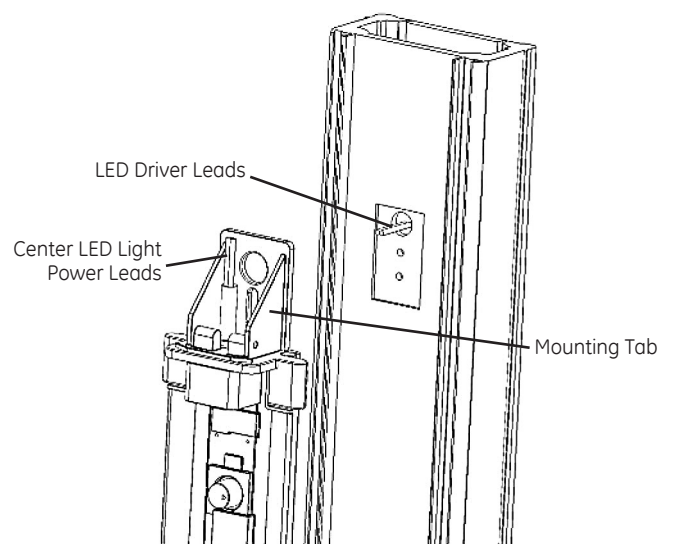

⚠ CAUTION/ATTENTION

Risk of injury. Do not overload LED Driver. Do not exceed limits shown in "Maximum LED Driver Loading" table below. **Risque de blessure.** Ne pas surcharger l'alimentation. Ne pas exéder les limites de la table ci-dessous: "Charges maximales pour les alimentations."

LED Driver Configuration Options

Both 50-watt and 100-watt LED Drivers are available for a variety of case configurations.

Maximum LED Driver Loading

	50W Driver	100W Driver
30-inch LED Lights	4 Center + 2 End	10 Center + 2 End
60-inch LED Lights	3 Center + 1 End	7 Center
67-inch LED Lights	3 Center	6 Center
48-inch LED Lights	4 Center	8 Center

(1 Center may be substituted by 2 End LED lights)

Parts Needed Per Case

	6-Door	5-Door	4-Door	3-Door	2-Door
Center LED Lights	5	4	3	2	1
End LED Light Sets	1	1	1	1	1
Wire Covers	7	6	5	4	3
Using 50W LED Drivers					
LED Drivers (30-inch LED Lights)	2	1	1	1	1
LED Drivers (60-inch LED Lights)	2	2	2	1	1
LED Drivers (67-inch LED Lights)	2	2	2	1	1
LED Drivers (48-inch LED Lights)	2	2	1	1	1
Using 100W LED Drivers					
LED Drivers (30-inch LED Lights)	1	1	1	1	1
LED Drivers (60-inch LED Lights)	1	1	1	1	1
LED Drivers (67-inch LED Lights)	2	1	1	1	1
LED Drivers (48-inch LED Lights)	1	1	1	1	1

⚠ WARNING/AVERTISSEMENT

Risk of electrical shock. Ensure that all connection points are sealed for damp location using the appropriate method per the NEC or local electrical code. **Risque de choc électrique.** S'assurer que les points de raccordements sont scellés pour emplacement humide en employant une méthode permise par le NEC ou par le code électrique local.

4 Connection Configurations

Multiple LED Light's electrical input should be in parallel connection to an LED driver's output as shown by the example wiring diagram below. Refer to "Maximum LED Driver Loading" table to determine maximum number of LED lights per LED driver.

One End Set (Right and Left) & One Center LED Light

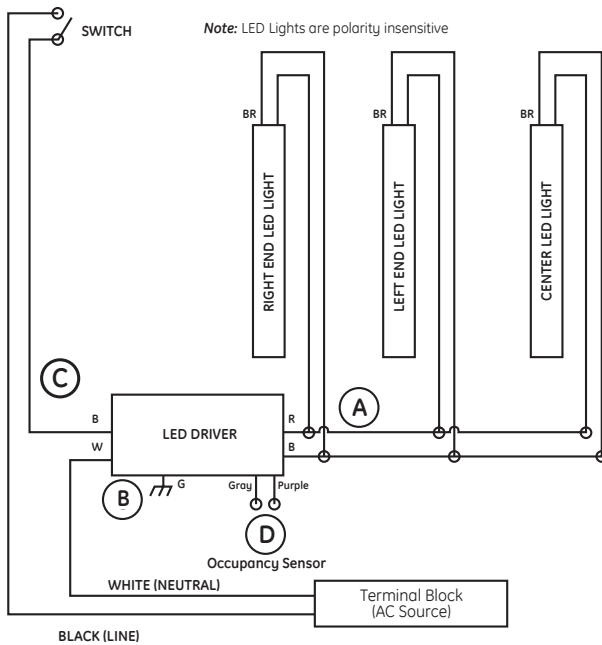

Driver Wire Connector Cavities
39-01-4030 (AC)
Cavity 1 - Line 1 (Black)
Cavity 2 - Earth Ground (Green)
Cavity 3 - Neutral or Line 2 (White)
39-01-4046 (DC)
Cavity 1 - Output DC (+) (Red)
Cavity 2 - Output DC (-) (Black)
Cavity 3 - Dimming (Purple)
Cavity 4 - Dimming (Gray)

For information on A, B, C, D, see Steps 4, 5 and 6.

5 Connect LED Driver - Output

- For retrofit, place LED driver in the location where the ballast was formerly located.
- Make output (DC) connections using one of the two options below:

USING TWIST-ON WIRE CONNECTORS

Remove the 4-way connector from the LED Driver by cutting the wires near the connector and strip the output leads. Using the appropriate wiring diagram on page 5, connect the LED Driver output leads to the LED Light leads. Use an ohm meter to identify the two wires connected to the LED Light that measure between ~ 15,000-18,000 ohms. Use wire connectors or other connection method approved for low temperature usage and stranded cable. **(A)**

For non-dimming applications, cap the unused wires with 5/32" (4mm) twist on wire connectors.

Bundle and safely secure any unused wires by way of approved wire ties and wire connectors.

6 Connect LED Driver - Input

- Make input (AC) connections as noted below:

USING TWIST-ON WIRE CONNECTOR

The LED Driver is required to be reliably bonded to the protective ground conductor. **(B)**

Attach the supplied green/yellow ground wire from the LED Driver to a grounded metal portion of the door frame. Remove the 3-way connector from the LED Driver by cutting the wires near the connector and strip the input wires. Using

the appropriate wiring diagram on page 5, connect the original Line and neutral wires (or Line 1 and Line 2 wires for 240 nominal VAC) to the LED Driver leads using the provided twist lock splice wire connectors or other connection method approved for low temperature usage and stranded cable. **(C)**

7 Connect Dimming Contacts – Output (Optional)

- To enable dimming operation, connect leads from occupancy sensor or control system (normally open contact) to the purple and gray leads of the power supply. Other methods, such as using occupancy sensors to switch the LED driver on and off is not recommended and will void the product warranty.
- Make output (contact closure) connections using one of the two options below:

USING TWIST-ON WIRE CONNECTORS

Remove the 4-way connector from the LED Driver by cutting the wires near the connector and strip the output leads. Using the appropriate wiring diagram on page 5, connect the LED Driver dimming output leads to the occupancy sensor or control system using wire connectors or other connection method approved for low temperature usage and stranded cable. **(D)**

- The **GEPS6100NCCON-SY** or **GEPS6500NCMUL-SY** LED Driver is capable of step dimming from 100% power to 20% power when used with a normally open contact closure occupancy sensor system.
- When using the **GEPS6100NCCON-SY** or **GEPS6500NCMUL-SY** for dimming applications, the slider switch setting must be set to the right to disable the dimming feature and achieve 100% illumination.

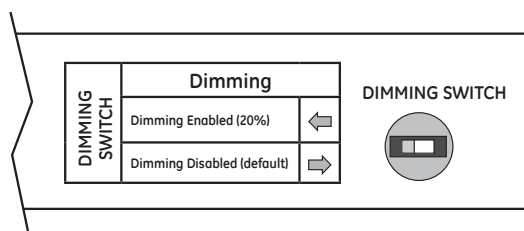

⚠ CAUTION/ATTENTION

Risk of electrical shock. Plastic cover is needed to protect electrical wires from tampering and accidental contact. / **Risque de choc électrique.** Le couvercle en plastique est requis pour assurer une protection adéquate contre l'accès aux fils et les contacts accidentels.

8 Attach Covers to Mounting Tab

- Tuck wires underneath Wire Cover before installing it onto the End Cap.
- Attach Wire Cover to LED Light Mounting Tab by inserting a M2.9x10 pan head tapping screw (provided) through the holes in Covers and Mounting Tabs using an installation torque of 3 lbf-in.

NOTE: Tighten slowly until fully seated, do not over tighten or strip the threads.

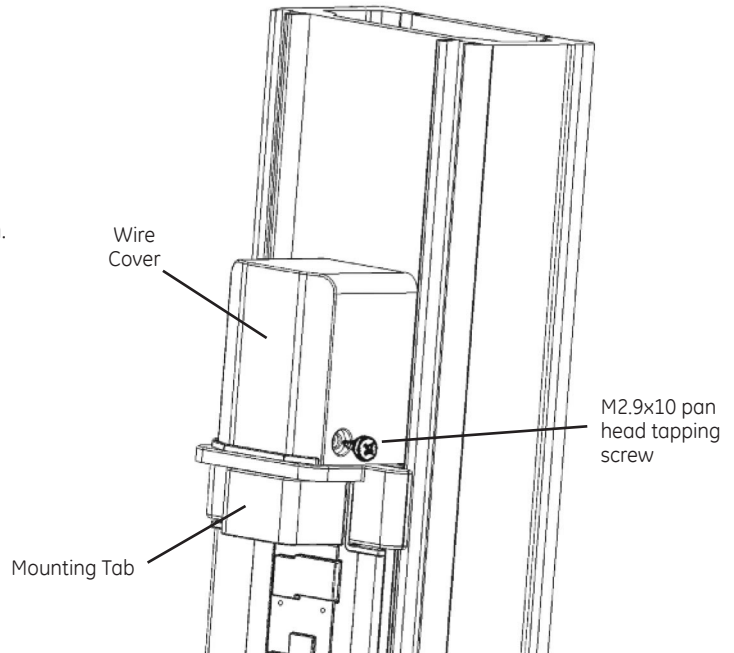

⚠ WARNING/AVERTISSEMENT

Risk of electrical shock. Disconnect power to LED Lights before any cleaning operation.
Risque de choc électrique. Débranchez l'alimentation des éclairages à LED avant toute opération de nettoyage.

9 LED Refrigerated Display Lights – Cleaning Instructions

- The outer lens and the plastic housing should be cleaned periodically with a mild liquid dish detergent.
- Do not use chemical cleaners to clean the lens.
- Keep the outside clean. Wipe with a clean cloth lightly dampened with mild liquid dish detergent. Dry with a clean, soft cloth.
- Do not wipe the lens with a soiled dish cloth or wet towel. These may leave a residue that can damage the finish.
- Do not use scouring pads, powdered cleaners, bleach or cleaners containing bleach because these products can scratch and damage the finish.

This product is intended solely for the use of commercial refrigerated, display or case lighting and is not intended for use in any other application.



www.gelighting.com

GE and the GE Monogram are trademarks of the General Electric Company. All other trademarks are the property of their respective owners. Information provided is subject to change without notice. All values are design or typical values when measured under laboratory conditions. GE Lighting is a business of the General Electric Company. © 2016 GE.

64134 (Rev 05/12/16)