

IMPORTANT SAFEGUARDS

When using electrical equipment, basic safety precautions should always be followed including the following:

READ AND FOLLOW ALL SAFETY INSTRUCTIONS

- DANGER**- Risk of shock- Disconnect power before installation.
DANGER – *Risque de choc – Couper l'alimentation avant l'installation.*
- This luminaire must be installed in accordance with the NEC or your local electrical code. If you are not familiar with these codes and requirements, consult a qualified electrician.
Ce produit doit être installé conformément à NEC ou votre code électrique local. Si vous n'êtes pas familier avec ces codes et ces exigences, veuillez contacter un électricien qualifié.
- Suitable for damp location.
Convient aux emplacements humides.
- Maximum ambient operating temperature: Medium Lumen Package = 50°C and High Lumen Package= 40°C.
Température ambiante maximale de fonctionnement: Paquet Moyen Lumens = 50°C et Paquet de Lumen Élevé = 40°C.
- MIN 90°C SUPPLY CONDUCTORS
LES FILS D'ALIMENTATION 90°C MIN.
- Check to make sure that all input power connections have been properly made and the module is grounded to avoid potential electrical shock.
- DO NOT lift luminaire by the power cord or any of the cables connected to the LED heatsink and LED driver.

SAVE THESE INSTRUCTIONS FOR FUTURE REFERENCE

TO INSTALL:

INSTALLATION INSTRUCTIONS INSTRUCTIONS D'INSTALLATION

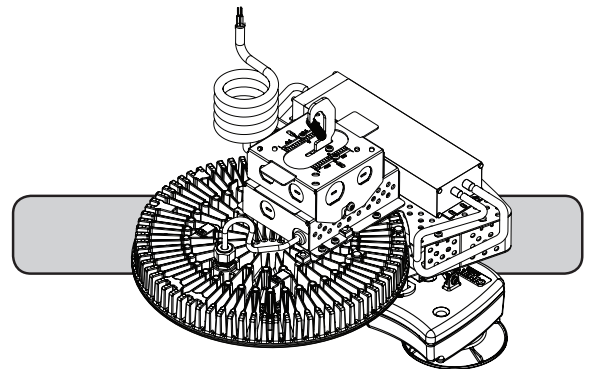

CXB pictured above is shown with the 120-277V High Lumen Sensor for illustration purposes only. For CXB with 120-277V Medium and all 347/480V sensor see instructions in the pages below.

NOTES:

- For each mounting application below, when mounting to surface ensure that the mounting surface and customer supplied hardware is capable of supporting the weight of the luminaire.
- The center of mounting is NOT the same as the center of luminaire.

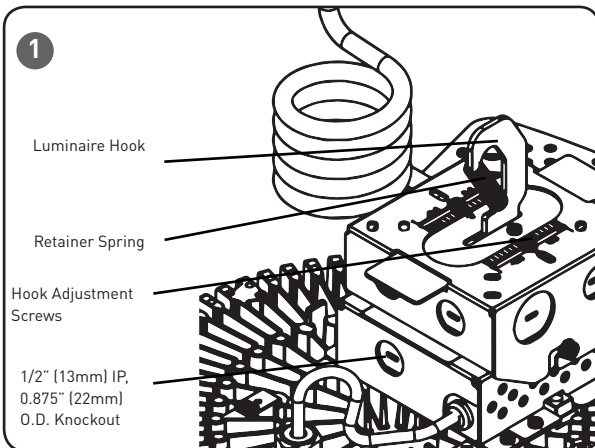

HOOK AND CORD MOUNT

STEP 1:

Push down on retainer spring until top of spring is free of luminaire hook. See **Figure 1**.

STEP 2:

Slide hook into securely mounted customer supplied eye hanger and return retainer spring to original position.

NOTE: The luminaire should already be factory set for correct balance. If necessary, the fixture may be balanced by loosening the hook adjustment screws on the top of the housing and sliding the hook as necessary for correct balance. Tighten hook adjustment screws when finished. See **Figure 1**.

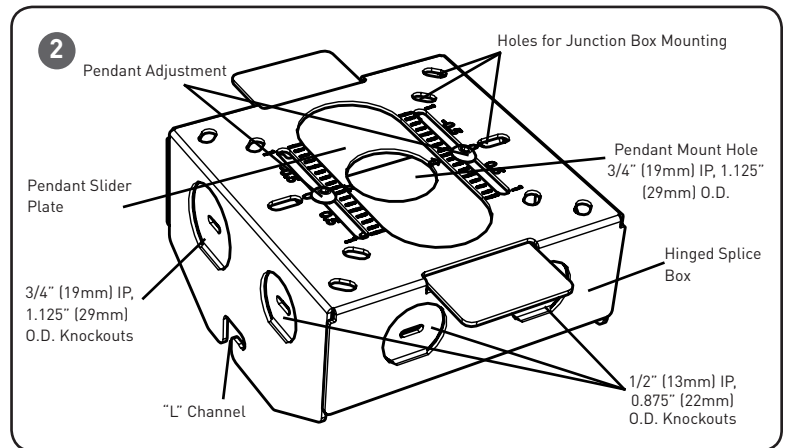

STEP 3:

Make wiring connections per the **Electrical Connections** section.

JUNCTION BOX MOUNT / PENDANT MOUNT

STEP 1:

Remove hinged splice box from top of housing by loosening screw and sliding box to the right and up from "L" channel. Unhook from hinge holes. See **Figure 2**.

STEP 2:

Remove hook, slider plate and cord and discard. Plug junction box knockout hole with provided junction box plug.

For pendant entering the hinged splice box:

Attach the supplied pendant mount slider plate using (2) supplied screws. Use 3/4" threaded pendant, along with two customer supplied locknuts (one for inside the hinged splice box and one for outside the splice box). Pull supply leads into position from customer supplied conduit.

Note: If necessary, the luminaire may be balanced by loosening (2) screws for pendant adjustment on the top of the hinged splice box and sliding the adjustment plate as necessary for correct balance. Tighten (2) screws when finished. See **Figure 2**.

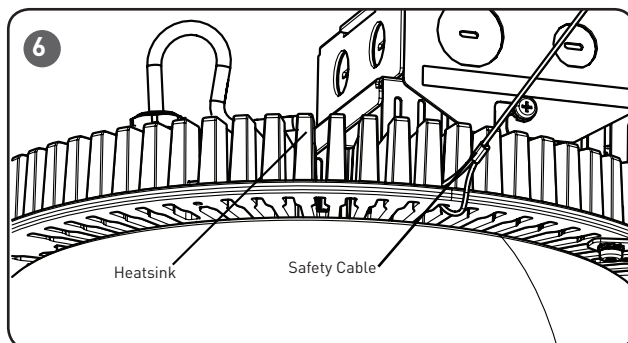
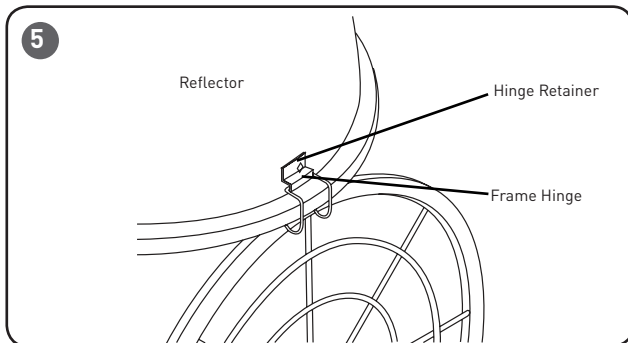
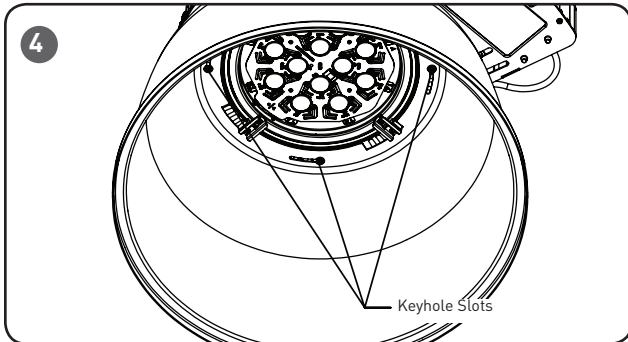
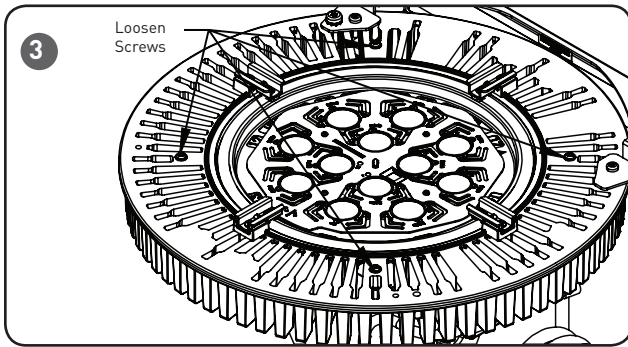

For junction box mounting the hinged splice box:

Use designated mounting holes on top of hinged splice box. See **Figure 2**. For conduit entering the hinged splice box from the side, use appropriately-sized threaded conduit (1/2" or 3/4"), and conduit fitting.

STEP 3:

Attach one end of the hinged splice box to luminaire by aligning hinge slots on Mounting Bracket with hinges (on splice box), and then inserting the hinges into the slots.

STEP 4:

Make wire connections per **Electrical Connections** and then push the leads into hinged splice box. Dimming wire conduit enters through the 1/2" knockout shown in **Figure 1**.

STEP 5:

Secure other end of the hinged splice box to luminaire by sliding screw on Mounting Bracket up and over in "L" channel on the hinged splice box. See **Figure 2**.

STEP 6:

Secure luminaire to hinged splice box by tightening screw.

REFLECTOR INSTALLATION

STEP 1:

Loosen the (4) screws, shown in **Figure 3**, at least 0.1 inch from the heatsink.

NOTE: The view in Figure 3 is of the underside of the luminaire.

STEP 2:

Bring trim into housing and line up the (4) screws from Step 1, with the keyhole slots on the reflector. See **Figure 4**.

STEP 3:

Rotate trim, turn clockwise and tighten the (4) screws from Step 1. See **Figure 4**.

Mounting Wire Guard

STEP 1:

Secure the hinge retainer and frame hinge to the reflector using supplied screw and lock nut. See **Figure 5**.

NOTE: Reflector is pre-punched at position of this installation.

STEP 2:

Swing the wire guard into place and secure to the reflector with the attached spring latch. See **Figure 5**.

INSTALLING SAFETY CABLE

NOTE: Safety Cable is sold separately as an accessory, please refer to installation sheet in safety cable packaging for complete installing instructions.

STEP 1:

Attach one end of the safety cable through the fin of the heatsink. See **Figure 6**.

STEP 2:

Attach other end of the safety cable to mounting surfaces using customer supplied hardware.

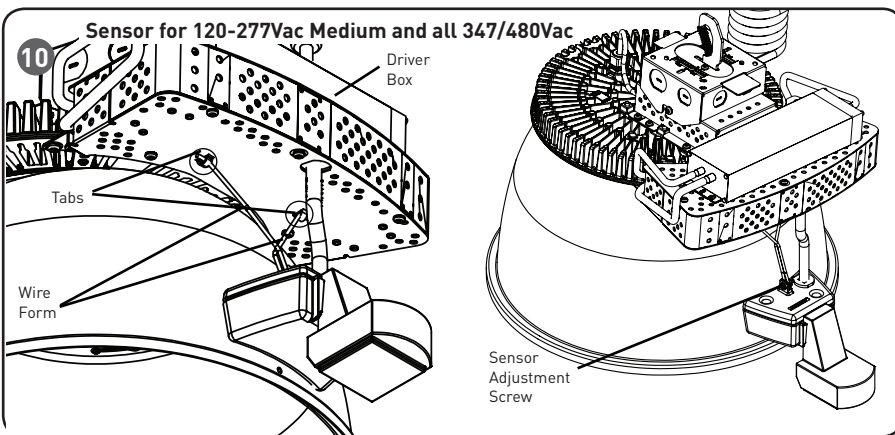
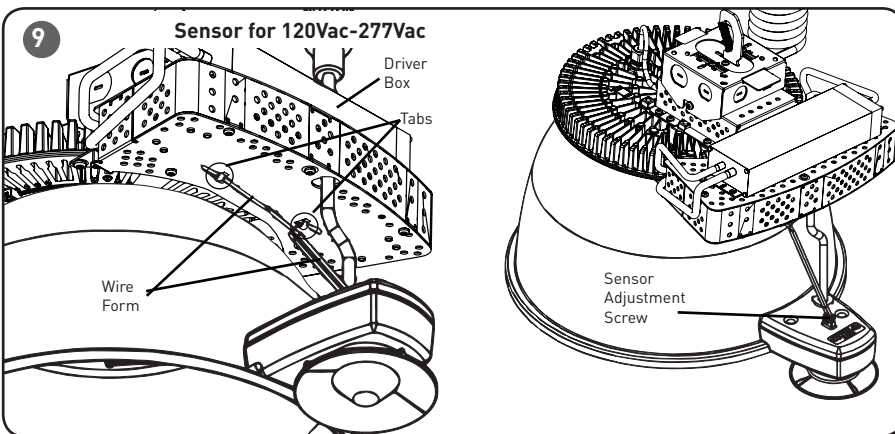
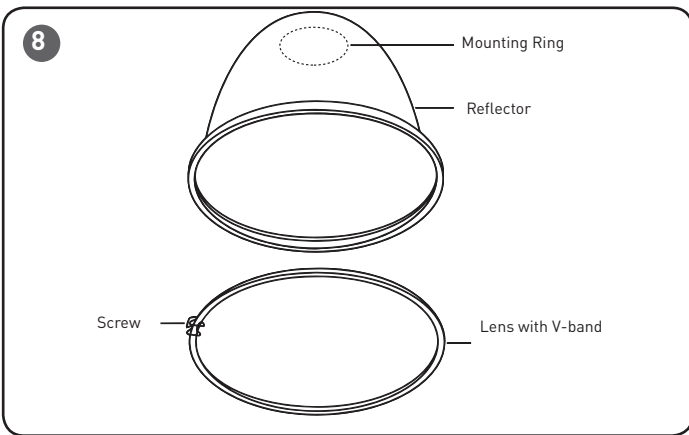
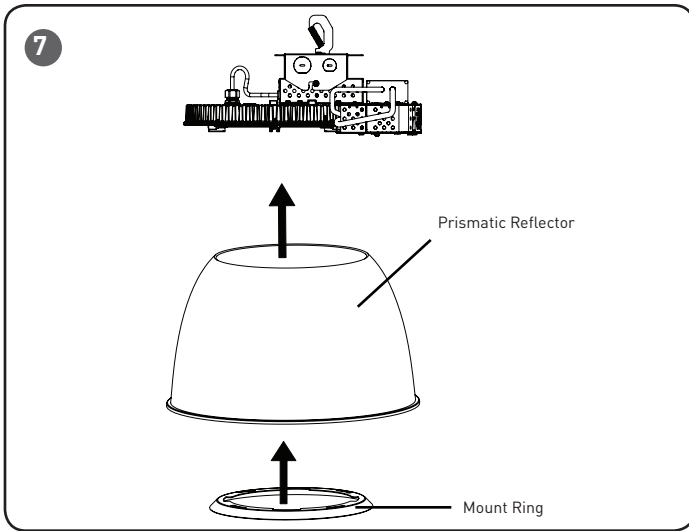

PRISMATIC REFLECTOR INSTALLATION

STEP 1:

Loosen the (4) screws, shown in **Figure 3**, at least 0.1 inch from the heatsink.

NOTE: The view in Figure 3 is of the underside of the luminaire.

STEP 2:

Bring Prismatic Reflector and mount ring up to the housing and lineup (4) screws from Step 1 with the keyhole slots on the mounting ring. See **Figure 7**.

STEP 3:

Rotate mount ring, turn clockwise and tighten the (4) screws from Step 1. See **Figure 4**.

Mounting Lens or Wire Guard

STEP 1:

Place lens or wire guard onto the bottom of reflector, and place V-band around lens and reflector. See **Figure 8**.

STEP 2:

Secure lens or wire guard to reflector by tightening screw on V-band. See **Figure 8**.

120-277VAC HIGH LUMEN SENSOR INFORMATION

NOTE: **Figure 9** shows 120-277Vac High Lumen Sensor and **Figure 10** shows 120-277Vac Medium Lumen and all 347/480Vac sensor. For 120-277V Medium Lumen and all 347/480Vac sensor information please refer to pages 7 and 8 under **120-277V Medium Lumen and all 347/480Vac Sensor Information** section.

INSTALLING SENSOR

STEP 1:

Locate the wire form on the sensor and install onto the luminaire by inserting the wire form into the (2) tabs under the driver box. See **Figures 9 and 10**.

STEP 2:

Ensure that the sensor is leveled. To level the sensor loosen the screw on the top side of the sensor, and retighten the screw once the sensor is leveled. See **Figures 9 and 10**.

SENSOR DESCRIPTION

The occupancy sensor controls high and low light levels based on occupancy and the selected ambient light level setting. The Ambient Light feature can be used to keep the lights from turning to high level if the ambient light level is sufficient.

The sensor uses passive infrared sensing (PIR) technology that reacts to changes in infrared energy (moving heat) within the coverage area. Once the space is vacant and the time delay elapses (adjustable from 30 seconds to 30 minutes), the luminaire will turn off or dim. Sensors must directly "see" motion of an occupant to detect them, so careful consideration must be given to sensor placement. Avoid placement where sensor's line of sight may be obstructed **IMPORTANT:** There is an initial warm-up period. It may take up to a minute before the lights turn on due to a sensor warm-up period required during initial power-up. This occurs during installation or after a lengthy power failure only.

Multi-Level Option Output Multipliers			
HIGH LUMEN PACKAGE (120-277V ONLY)			
Low Dim Setting	0-10V	Power Multiplier	Lumen Multiplier
0	---	OFF	OFF
1	1.3V	0.14	0.14
2	1.8V	0.19	0.19
3	2.1V	0.22	0.22
4	2.4V	0.25	0.25
5	3.0V	0.30	0.31
6	3.5V	0.35	0.36
7	4.0V	0.39	0.41
High Dim Setting	0-10V	Power Multiplier	Lumen Multiplier
0	4.2V	0.41	0.43
1	5.1V	0.51	0.53
2	5.8V	0.57	0.59
3	6.3V	0.62	0.64
4	6.5V	0.64	0.66
5	6.9V	0.68	0.70
6	7.7V	0.76	0.77
7	10V	1.00	1.00

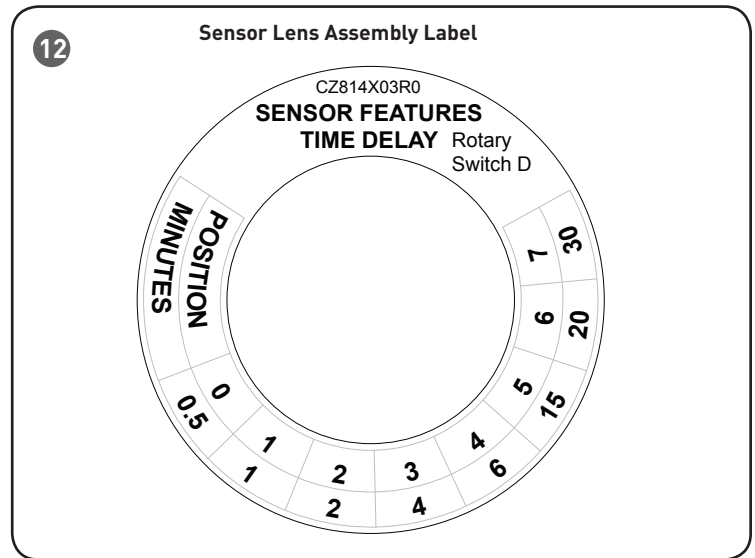
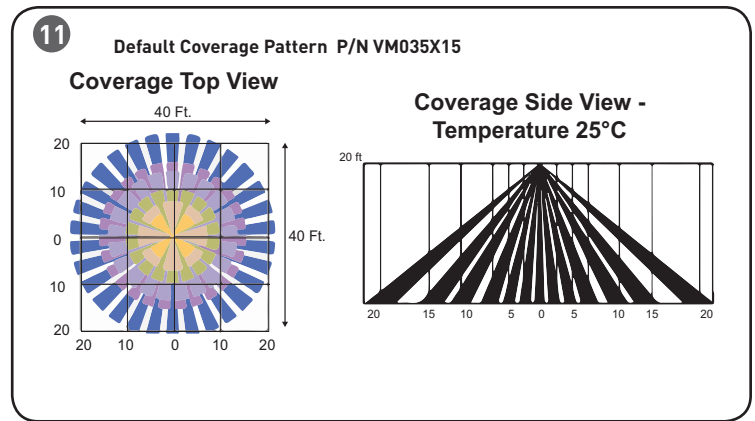

SENSOR COVERAGE PATTERN

20' (6.1m) optimal mounting height and 40' (12.2 m) diameter coverage area with a 360° circular pattern. The minimum and maximum mounting heights are 10' (3m) and 30' (9.1m) respectively. Lens mounting height to coverage radius ratio is 1:1. See **Figure 11**.

SENSOR ADJUSTMENTS

NOTE: Adjustments to these settings require the user to remove the sensor lens assembly to access the features listed on page 5; features are located under the lens assembly. Grasp the lens assembly and turn it counterclockwise a quarter turn. Do not remove the plastic nut; it holds the sensor in place. Adjust the Ambient Level switch settings during daylight hours when ambient light is at desired level. See PAGE 5 for the full details of the sensor features. Refer to the table below for default factory setting.

Default Factory Setting	
A	0
L	7
H	7
D	0

POWER DATA

NOTE: Multipliers are for estimating purposes only.

When the sensor settings are changed, it will impact both the power consumption and the fixture light output. In order to achieve the ideal settings for the intended application, consult the following data charts on the left.

13

Sensor Factory Settings

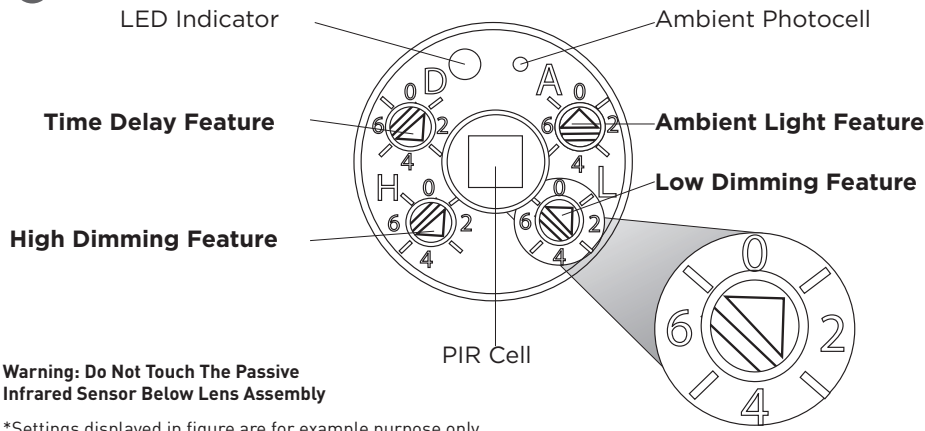

Warning: Do Not Touch The Passive Infrared Sensor Below Lens Assembly

*Settings displayed in figure are for example purpose only.

AMBIENT LIGHT SETTINGS	
Ambient Light Setting (A)	Feature
0	OSO
1	OSTO
2	OSLA
3	OSHA
4	OSLATO
5	OSHATO
6	LL
7	Test/LH

SENSOR OPERATION - 120-277VAC HIGH LUMEN

HIGH DIMMING FEATURE (H):

The High Dimming feature (Rotary switch H) has eight possible settings. See **Multi-Level Option Output Multipliers** tables on page 4 for the complete range available.

NOTE: The sensor will not allow the maximum rated drive current of the luminaire to be exceeded.

LOW DIMMING FEATURE (L):

The Low Dimming feature (Rotary switch L) has eight possible settings and can be adjusted from an off position (position 0) to a maximum drive current (position 7). See **Multi-Level Option Output Multipliers** tables on page 4 for the complete range available.

TIME DELAY FEATURE (D):

The Time Delay feature (Rotary switch D) has eight possible settings and can be adjusted from 0.5 min (position 0) to 30 min (position 7). See **Figure 12** for the complete range available. Once motion is detected, the lighting level will remain in high mode until no activity is detected for the duration of the time delay cycle that has been selected.

AMBIENT LIGHT FEATURE (A):

The Ambient Light feature (Rotary switch A) has eight possible settings and provides the ability to employ daylight harvesting. It also includes a test mode, as well as lock low and lock high settings. See **Ambient Light Settings** table above for complete range available – a more detailed description of each setting is below.

Occupancy Sensing Only (OSO): Occupancy detection (PIR) enabled only. Ambient Light sensing (ambient photocell) is disabled. The sensor will switch the luminaire to High mode during occupancy detection regardless of environment light levels and will remain so per selected setting in Time Delay feature. After no occupancy is detected during Time

Delay cycle, luminaire will switch to Low mode (factory default).

Occupancy Sensing and Time Off (OSTO):

Occupancy detection (PIR) enabled only with Time Off operation. Ambient light sensing (ambient photocell) is disabled. The sensor will switch the luminaire to High mode during occupancy detection regardless of environment light levels and will remain so per selected setting in Time Delay feature. After no occupancy is detected during Time Delay cycle, luminaire will switch to Low mode. Sensor will switch the luminaire to Off after 30 minutes of no occupancy detection (Low mode). The luminaire will move immediately back into high mode from off once motion is detected.

Occupancy Sensing and Low Ambient (OSLA):

Occupancy detection (PIR) and Ambient Light sensing (ambient photocell) enabled. During transitional periods from night to day once environment light levels exceed 130 Lux (12 FC) and no occupancy is detected for the time delay duration, luminaire will be turned Off. During transitional periods from day to night when environment light levels fall below 80 Lux (7 FC), luminaire will switch from OFF to Low mode during no occupancy and switch to High mode after occupancy is detected.

Occupancy Sensing and High Ambient (OSHA):

Occupancy detection (PIR) and Ambient Light sensing (ambient photocell) enabled. During transitional periods from night to day once environment light levels exceed 600 Lux (55 FC) and no occupancy is detected for the time delay duration, luminaire will be turned Off. During transitional periods from day to night when environment light levels fall below 500 Lux (46 FC), luminaire will switch from OFF to Low mode during no occupancy and switch to High mode after occupancy is detected.

Occupancy Sensing, Low Ambient and Time Off (OSLATO):

Occupancy detection (PIR), Ambient Light sensing (Photocell) and Time Off enabled. During transitional

periods from night to day once environment light levels exceed 130 Lux (12 FC), luminaire will remain OFF regardless of occupancy. If environment light levels are below 80 Lux (7 FC) and occupancy is detected, luminaire will switch to High mode and remain so per selected setting in Time Delay feature. After no occupancy is detected during Time Delay cycle, luminaire will switch to Low mode. Sensor will switch the luminaire OFF after 30 minutes of no occupancy detection.

Occupancy Sensing, High Ambient and Time Off (OSHATO):

Occupancy detection (PIR), Ambient Light sensing (ambient photocell) and Time Off enabled. During transitional periods from night to day once environment light levels exceed 600 Lux (55 FC) and no occupancy is detected for the time delay duration, luminaire will be turned Off. During transitional periods from day to night when environment light levels fall below 500 Lux (46 FC), luminaire will switch from OFF to Low mode during no occupancy and switch to High mode after occupancy is detected. Sensor will switch the luminaire Off after 30 minutes of no occupancy detection (Low mode). The luminaire will move immediately back into high mode from off once motion is detected and ambient light is less than approximately 600 Lux (55 FC).

Lock Low Mode (LL):

Sensor locks in Low Dimming level indefinitely per dimming switch (L) setting. The occupancy detection (PIR) and Ambient Light (ambient photocell) operation are disabled during the Lock Low mode.

Test/Lock High Mode (Test/LH): The sensor turns the fixture on at the low level set by dimming switches. Sensor will cycle every 5 seconds between the specified Low and High dimming settings for 4 complete cycles (Low, High, Low, High) and then locks in High indefinitely. The occupancy detection (PIR) and Ambient Light (ambient photocell) operation are disabled during the Test/Lock High mode

TESTING OCCUPANCY SENSOR – HIGH AND LOW DIMMING FEATURES

STEP 1:

Turn fixture off.

STEP 2:

Remove lens assembly. Grasp the lens assembly and turn it counterclockwise a quarter turn.

STEP 3:

Turn Ambient Light switch to test mode, position 7.

STEP 4:

Turn fixture on.

STEP 5:

The fixture should turn on and cycle every 5 seconds between the high and low dimming settings for 4 complete cycles.

STEP 6:

Return Ambient Light switch to desired position.

TESTING SENSOR DETECTION OPERATION

STEP 1:

Remove lens assembly. Grasp the lens assembly and turn it counterclockwise a quarter turn.

STEP 2:

Turn Time Delay switch to position 0 (0.5 min).

STEP 3:

Turn Ambient Light switch to position 0 (OSO).

STEP 4:

Leave controlled area and let the fixture turn off or go to low mode.

STEP 5:

Enter the controlled area, fixture should turn on or go to high mode.

STEP 6:

Adjust sensor to desired settings and replace sensor lens assembly.

- b. Check Ambient Light settings. Cover the sensor lens to simulate darkness in the room. If the lights come on, the Ambient Level needs to be adjusted. For instance, if Ambient Level switch is set in position 2 or 4, ambient light levels higher than this setting will keep lights off. See Testing and Adjusting Ambient Level section for instructions.

Lights Will Not Turn Off Or Stay In Low Mode

STEP 1:

Remove lens. Grasp the lens and turn it counterclockwise a quarter turn.

STEP 2:

Check Time Delay switch settings and turn it to position 0 (0.5 min).

STEP 3:

Check Ambient Light setting and turn it to position 0 (OSO) and leave controlled area. The fixture should turn off or stay in low mode.

STEP 4:

If fixture does not turn off or stay in low mode, call 1-800-236-6800 for technical support.

TROUBLESHOOTING

Lights Will Not Turn On Or Go To High Dimming Mode

LED on sensor does not flash

- a. Check all wire connections and verify the ground wire is tightly secured.

LED on sensor does flash

- a. Check all wire connections and verify the ground wire is tightly secured.

ELECTRICAL CONNECTIONS

STEP 1:

Make the following Electrical Connections :

- a. Connect the black fixture lead to the voltage supply or Hot 1.
- b. Connect the white fixture lead to the neutral supply or Hot 2.
- c. Connect the green or green/yellow ground lead to the green wire position of the terminal block.

STEP 2:

For Dimming make the following Electrical Connections:

NOTE: The incoming signal cable needs to pass through the 1/2" knockout shown in **Figure 2** on page 2.

- d. If Dimming is an option; connect the violet dimming positive lead to the supply dimming positive lead.
- e. If Dimming is an option; connect the grey dimming negative lead to the supply dimming negative lead.

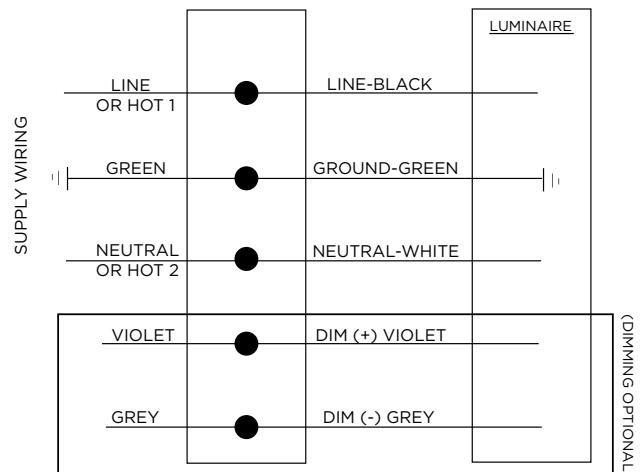

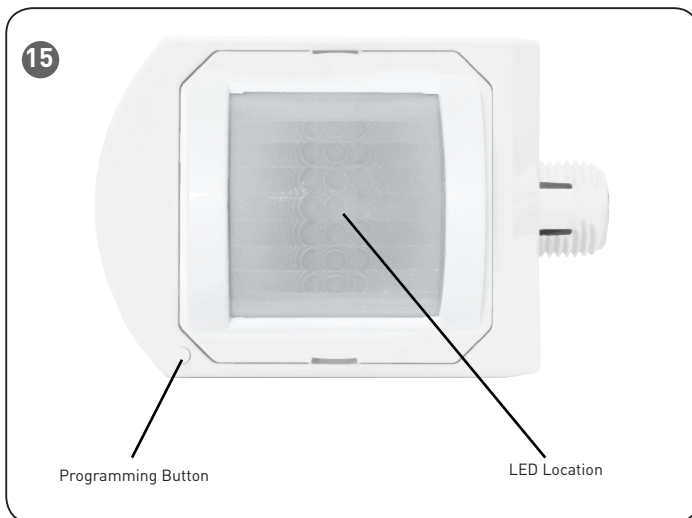
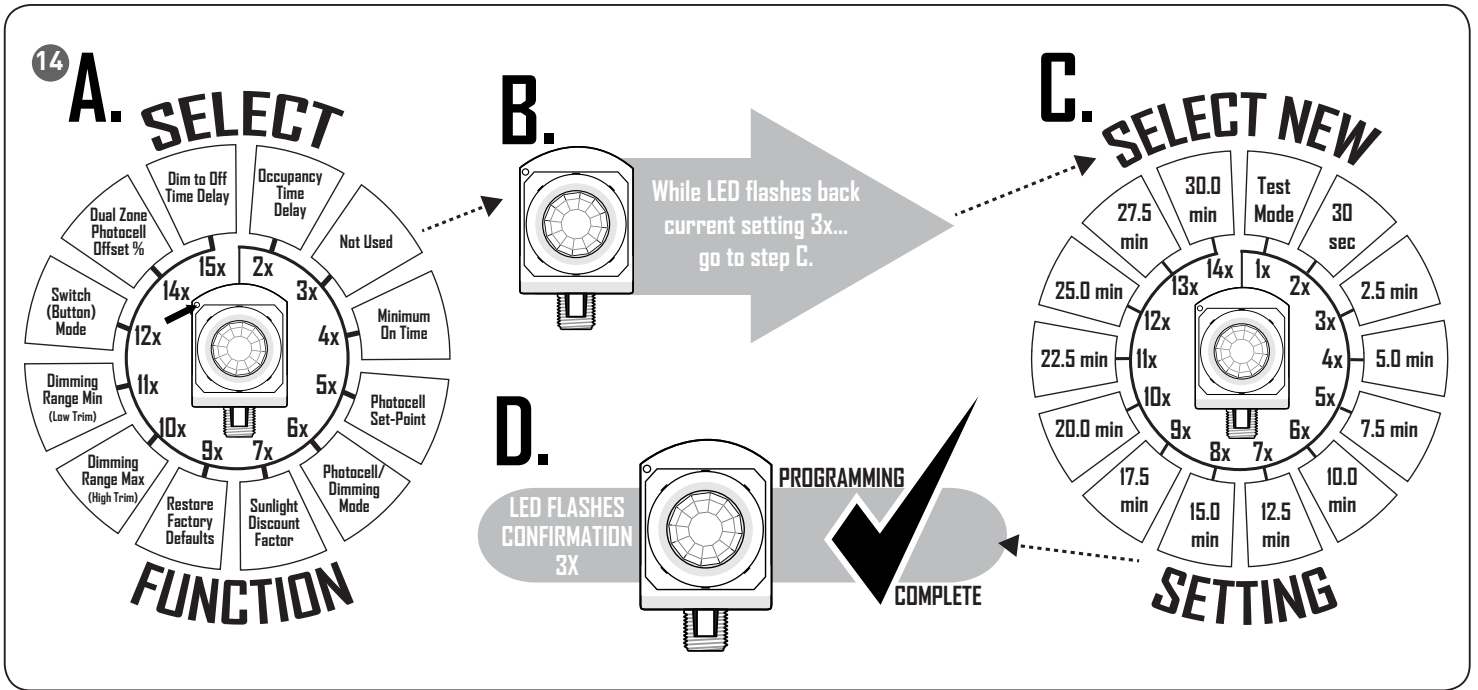

120-277V MEDIUM AND ALL 347/480VAC SENSOR INFORMATION

PROGRAMMING INSTRUCTIONS

Operational settings can be changed via the push-button sequence outlined below.

NOTE: the example used is for changing occupancy time delay:

STEP 1:

Enter a programming function by pressing the programming button the number of times as the desired function as shown in **Figures 14 and 15**. (e.g., press twice for function 2, occupancy time delay).

STEP 2:

LED will flash back the selected function's current setting (e.g., 6 flashes for 10 minute time delay). To change setting, proceed to step 3 before flash back sequence repeats 3 times. To exit the current function or to change to a different function, wait for sequence to repeat 3 times then return to step 1. See **Figures 14 and 15**.

STEP 3:

Press the programming button the number of times indicated in the particular function's detailed table for the NEW desired setting (e.g., press 4 times for 5 min).

STEP 4:

As confirmation of setting change, LED flashes back the NEW setting 3 times before exiting.

COVERAGE PATTERN

Best choice for 15 to 45 ft (4.57 to 13.72 m) mounting heights, 15 to 20 ft (4.57 to 6.10 m) radial coverage overlaps area lit by a typical high mount fixture. Excellent detection of large motion (e.g. walking) up to a 35 ft (10.76 m) mounting height. Excellent detection of extra large motion (e.g. forklifts) up to a 45 ft (13.72 m) mounting height. See **Figure 16** on next page.

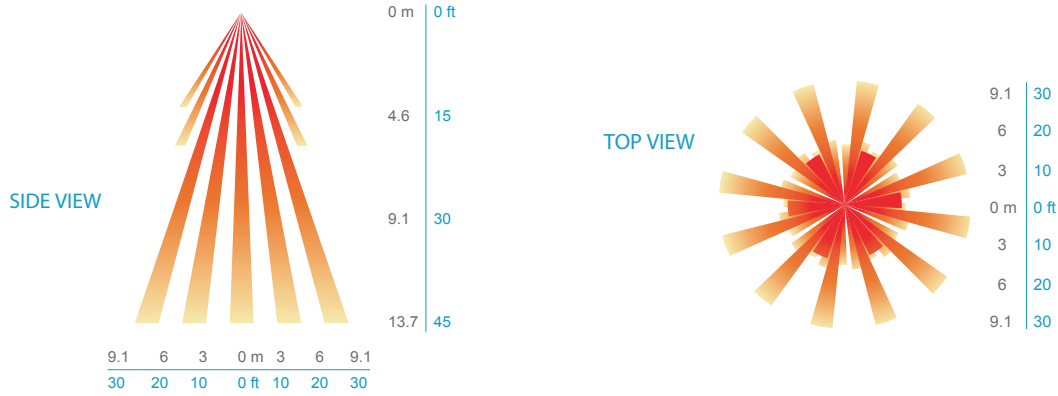

SENSOR OPERATION - 120-277V MEDIUM AND ALL 347/480VAC

*Indicates default.

OCCUPANCY TIME DELAY (2)

The length of time the sensor will keep the lights on (and at full bright if applicable) after it last detects occupancy, assuming Minimum On Time (function 4) has been met (or is disabled).

1 Test Mode**	6 10.0 min	11 22.5 min
2 30 sec	7 12.5 min	12 25.0 min
3 2.5 min	8 15.0 min*	13 27.5 min
4 5.0 min	9 17.5 min	14 30.0 min
5 7.5 min	10 20.0 min	

**Test mode disables Minimum On Time (Function 4), sets Occupancy Time Delay (Function 2 & 3) to 30 sec, and shortens the photocell transition times and dimming rate. Mode will expire after 10 min or if Function 2 is set back to a time delay.

MINIMUM ON TIME; LAMP MAXIMIZER (4)

The length of time required for lamps to be on in order to prevent short cycling that reduces fluorescent lamp life. If occupancy time delay expires prior to minimum on time being satisfied, the lamps will remain on until time has been met.

1 0 min (disabled) *	2 15 min	4 45 min
	3 30 min	5 60 min

PHOTOCELL SET-POINT (5)

The target light level (at the sensor) that is to be maintained. Selecting Auto (Setting 1) will initiate on/off cycling procedure where sensor finds close-loop set-point.

1 Auto	4 2.0 fc	7 16.0 fc
2 0.5 fc	5 4.0 fc*	8 32.0 fc
3 1.0 fc	6 8.0 fc	9 64.0 fc

PHOTOCELL / DIMMING (6)

Units with ADC or ANL (Dimming) Options:

- 1. Disabled:** Photocell does not affect lights.*
- 2. Automatic Dimming & Switching (-ADC):** Enables the sensor during occupied periods to dim lights down and then turn them completely off by opening the relay.
- 3. Combination Dimming & Switching Photocell w/ High/Low Occ. Operation (-ANL):** Provides maximum energy savings by dimming lighting during periods of sufficient daylight contribution from windows or skylights. During unoccupied periods without sufficient daylight lights are dropped to low dim setting, insuring minimum light levels are maintained at night.

SUNLIGHT DISCOUNT FACTOR (7)

Value used to improve the tracking accuracy of a sensor with a photocell during periods of high daylight. Decreasing the value will lower the controlled level of the lights.

1 x/1*	4 x/4	7 x/7	10 x/10
2 x/2	5 x/5	8 x/8	
3 x/3	6 x/6	9 x/9	

RESTORE FACTORY DEFAULTS (9)

Returns all functions to original settings.

- 1 Maintain Current*
- 2 Restore Defaults

DIMMING RANGE MAX; HIGH TRIM (10)

The maximum output level of a sensor with dimming.

1 N/A	4 3 VDC	7 6 VDC	10 9 VDC
2 1 VDC	5 4 VDC	8 7 VDC	11 10 VDC*
3 2 VDC	6 5 VDC	9 8 VDC	

DIMMING RANGE MIN; LOW TRIM (11)

For sensors with -ADC or -ANL option, this setting is the minimum output level to which the photocell will dim the lights.

Also, this setting is the dim level the lights will drop to when the Occupancy Time Delay (Function 2) expires. See tables on the last page.

NOTE: In -ADC mode lights will still turn completely off after the Dim to Off Occupancy Time Delay (Function 15) expires.

1 N/A	4 3 VDC	7 6 VDC	10 9 VDC
2 1 VDC*	5 4 VDC	8 7 VDC	11 10 VDC
3 2 VDC	6 5 VDC	9 8 VDC	

SWITCH (BUTTON) MODE (12)

When enabled, mode allows user to switch the relay by pressing the push button for test purposes (e.g., in order to test wiring). Note there is a short delay after pushing the button before the relay switches.

- 1 Disabled*
- 2 Enabled

DIM TO OFF OCCUPANCY TIME DELAY (15)

After the Occupancy Time Delay (Function 2) has expired, this setting specifies the amount of time lights are held at minimum dim (Function 11) before turning off. Setting is only applicable for sensors with -ADC dimming options.

1 0 sec	5 7.5 min	9 17.5 min
2 30 sec	6 10.0 min	10 20.0 min
3 2.5 min	7 12.5 min	11 Stays at dim (never off)*
4 5.0 min	8 15.0 min	

Sensor switch Output Multipliers 120-277V		
MEDIUM LUMEN PACKAGE		
0-10V Dim Voltage	Power Multiplier	Lumen Multiplier
0V	0.04	0.03
1V	0.13	0.13
2V	0.23	0.23
3V	0.33	0.32
4V	0.42	0.42
5V	0.52	0.52
6V	0.61	0.61
7V	0.71	0.71
8V	0.80	0.81
9V	0.90	0.90
10V	1.00	1.00

Sensor switch Output Multipliers 347-480V		
MEDIUM LUMEN PACKAGE		
0-10V Dim Voltage	Power Multiplier	Lumen Multiplier
0V	0.02	0.00
1V	0.13	0.12
2V	0.23	0.22
3V	0.32	0.31
4V	0.42	0.41
5V	0.51	0.51
6V	0.61	0.61
7V	0.71	0.71
8V	0.80	0.80
9V	0.90	0.90
10V	1.00	1.00

NOTE:
Refer to page 4 for 120-277V High Lumen Package
Sensor information.

Sensor switch Output Multipliers 347-480V		
HIGH LUMEN PACKAGE		
0-10V Dim Voltage	Power Multiplier	Lumen Multiplier
0V	0.01	0.00
1V	0.12	0.12
2V	0.22	0.21
3V	0.31	0.31
4V	0.41	0.41
5V	0.50	0.51
6V	0.60	0.61
7V	0.70	0.71
8V	0.80	0.80
9V	0.90	0.90
10V	1.00	1.00

