

**INSTALLATION PROCEDURES**

- **Housing can NOT be installed in direct contact with insulation.** Do not install insulation within 3" of fixture sides or wiring compartment, nor above fixture in such a manner to entrap heat. (Figure 1)
- Install hanger bars to fixture; ensure end tab is facing outward. (Figure 2)
- Extend bar hangers to fit between joists and position fixture by hammering nail on bars into the joists. Hangers should be level with bottom of the joists.
- Use T-Bar slot in the bottom bars for suspended (T-Bar) ceilings, bending the tabs to hold T-Bar tightly.
- Make all necessary electrical connections (See "Electrical Connection").

**ELECTRICAL CONNECTION:**

- Local electrical codes should be consulted to determine acceptable installation: conduit, Romex or flexible metal cable.
- Remove the junction box cover.
- Follow the proper wiring diagram for the electrical/dimming option (PAGE 2). Ensure wiring is the correct voltage for the fixture – either 120V, 277V or 347V.
- **Wiring Diagram 1:** 12D, 27D, 34D2, 12D6, 27D6, 12D8, 27D8 (Triac, ELV or 0-10V). Note: When dimming with 0-10V, Class 1 wiring (300V wiring inside conduit) is required. Please consult factory for additional details.
- **Wiring Diagram 2:** 12D3 (Lutron HiLume)
- **Wiring Diagram 3:** 12D4, 27D4 (Lutron EcoSystem)
- **Wiring Diagram 4:** 12D7, 27D7, 12D9, 27D9 (DALI)
- **Wiring Diagram 5:** 12DMX, 27DMX, MVDMX (DMX)
- Close junction box cover after wiring. Ensure all wires are safely within junction box before closing.

**TRIM AND LED MODULE INSTALLATION (TRIMMED):**

- Remove protective cover from LED Module.
- If using a decorative trim assembly with separate trim ring, place ring on reflector prior to assembly.
- Attach reflector to LED Module by aligning tabs, then twist and lock into place (Figure 3). For two-piece trim assemblies with lenses, install upper reflector with a twist and lock, then complete the trim assembly by simply pushing the lower assembly into the LED module. Friction clips secure lower assembly in LED module.
- Make the LED Module electrical connection. (Figure 4A)
- Carefully route excess wire out of the way; align metallic connector to heat-sink and snap in place. (Figure 4B)
- Push LED Module with assembled reflector through the hole in mounting frame until flush with ceiling. LED Module is held securely in place with spring clips located on housing frame.

**MUD FRAME, TRIM AND LED MODULE INSTALLATION (TRIMLESS):**

- Once gypsum board (wallboard) ceiling has been installed, the mud frame can then be installed. It's important to note, the deep side of the mud frame collar gets inserted up into the housing, so the shallow side is room facing. Align notches in Mud Frame with notches in housing mounting frame. This will align holes in Mud Frame with hole patterns in mounting frame. Secure Mud Frame to ceiling and housing with four (4) self-drilling screws provided. (Figure 5)
- Joint compound can now be applied to ceiling and Mud Frame.
- After finish coat paint has been applied to ceiling, ensure inner groove in Mud Frame is clear from excess joint compound and paint, so reflector will seat properly. (Figure 6)
- Remove protective cover from LED Module.
- Attach reflector to LED Module by aligning tabs, then twist and lock into place (Figure 3).
- Make the LED Module electrical connection. (Figure 4A)
- Carefully route excess wire out of the way; align metallic connector to heat-sink and snap in place. (Figure 4B)
- Push LED Module with assembled reflector through the hole in mounting frame until flush with ceiling. LED Module is held securely in place with spring clips located on housing frame.

**REPLACEMENT OF LED DRIVER:**

**NOTE:** LED Driver should be replaced by a qualified electrician. Turn off power at fuse or circuit breaker box before replacing the LED Driver.

- Pull and drop the trim and LED Module from the frame.
- Disconnect the electrical connection. (Figure 4)
- Remove the J-Box cover with LED Driver attached to it by releasing retention spring on top of J-Box. (Figure 7)
- Disconnect LED Driver from line voltage input wiring in J-Box. Disconnect the LED Driver from the LED leads (leads are terminated by crimp connectors).
- Reinstall Factory Approved LED Driver by reversing above procedure.

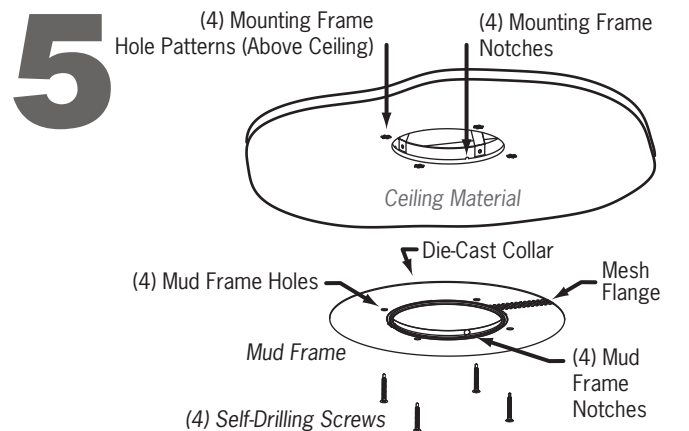
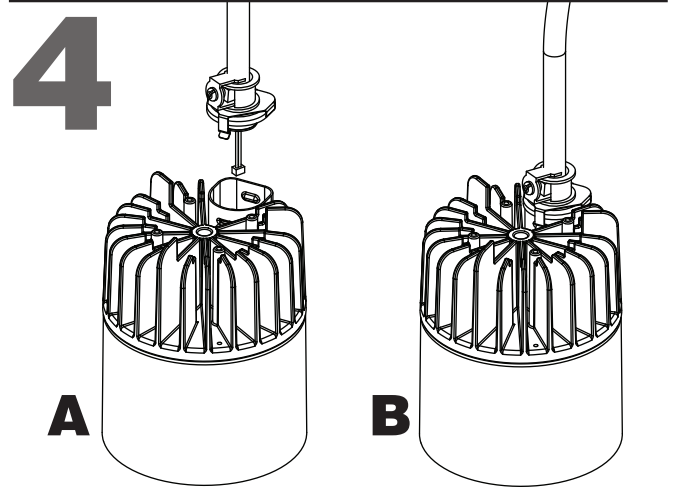
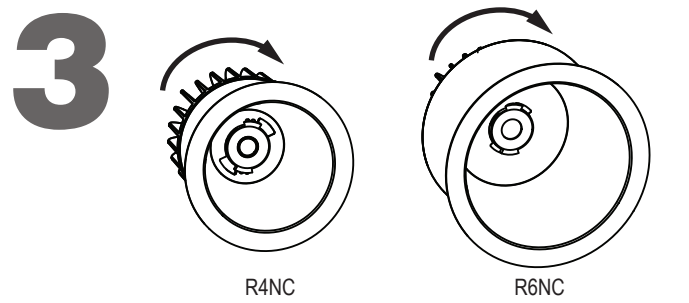
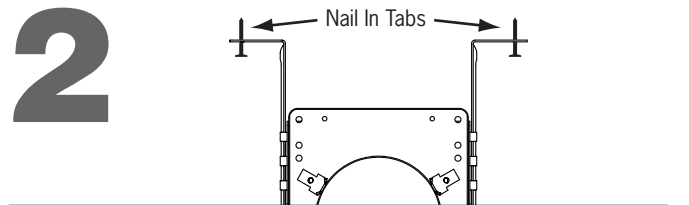
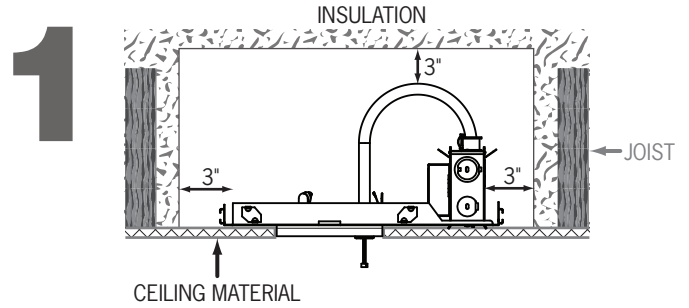

**IMPORTANT SAFETY INSTRUCTIONS:**

- Read all the instructions before installation. Save instructions for later use.
- Turn off power at fuse or circuit breaker box before installation or before doing any maintenance work.
- Product must be grounded to avoid potential electric shock and any other potential hazards.
- Product must be mounted in locations and at heights and in a manner consistent with its intended use, and in compliance with National Electrical Code and local codes. Use of accessory equipment is not recommended.
- Installing contrary to instructions may cause unsafe conditions.
- Do not block light from the trim aperture, in whole or in part, as this may cause unsafe conditions.
- Warning: Risk of fire. Most dwellings built before 1985 have supply wire rated at 60°C. Consult a qualified electrician before installation.
- Avoid hazards to children: account for all parts and properly dispose of all packing materials.
- Call the Technical Support department at ConTech Lighting with any installation questions: 847.559.5500.

**WARRANTY**

Energy Star products are covered for three (3) years by a full replacement guarantee after date of installation. In addition, ConTech LED products carry a five (5) year limited warranty from date of purchase.

**6**

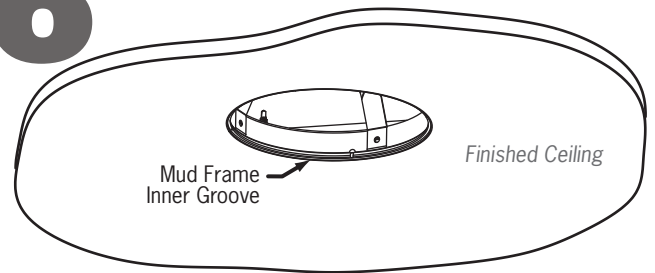

**7**

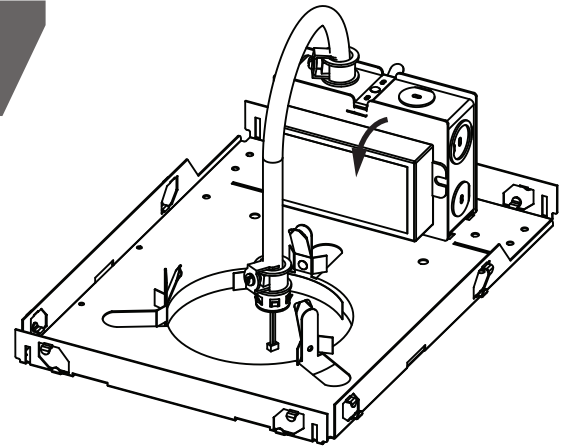

WIRING DIAGRAMS

WIRING DIAGRAM-1

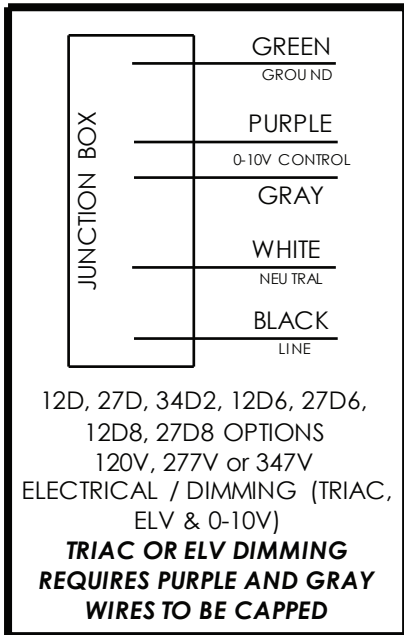

WIRING DIAGRAM-2

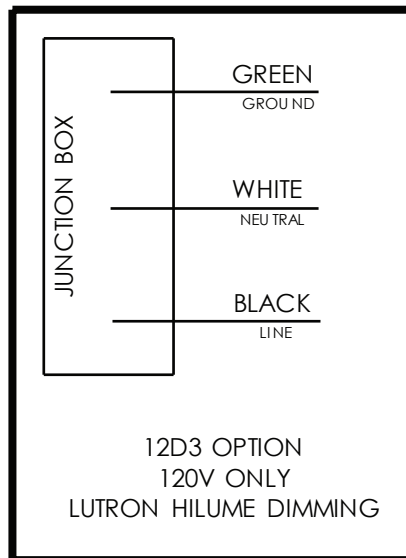

WIRING DIAGRAM-3

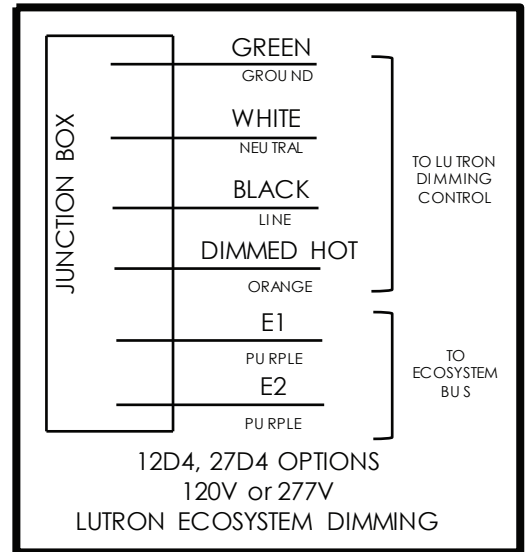

WIRING DIAGRAM-4

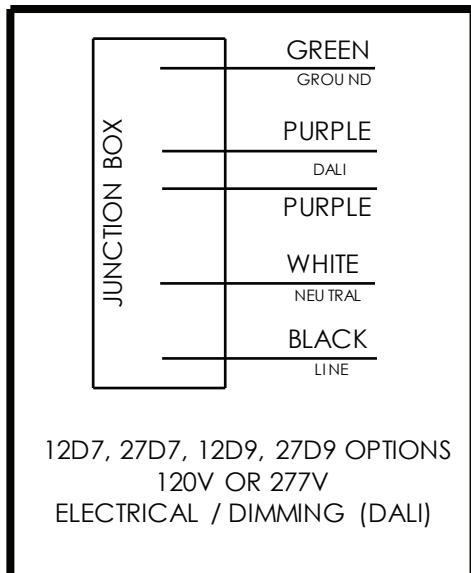

WIRING DIAGRAM-5

