



INSTALLATION INSTRUCTIONS

MINI GENIE RECESSED EMERGENCY LIGHT

IMPORTANT SAFEGUARDS

When using electrical equipment, basic safety precautions should always be followed including the following:

READ AND FOLLOW ALL SAFETY INSTRUCTIONS

1. Before wiring to power supply, disconnect power at fuse or circuit breaker.
2. Disconnect A.C. power before servicing.
3. Refer to wiring instructions sheet for proper connections.
4. Consult your local building code for approved wiring and installation.
5. Do not use outdoors.
6. Do not mount near gas or electric heaters.
7. Equipment should be mounted in locations and at heights where it will not readily be subject to tampering by unauthorized personnel.
8. The use of accessory equipment not recommended by the manufacturer may cause an unsafe condition.
9. Caution: Halogen cycle lamps are used in this equipment. To avoid shattering: Do not operate lamp in excess of rated voltage, protect lamp against abrasion and scratches and against liquids when lamp is operating, dispose of lamp with care.
10. Halogen cycle lamps operate at high temperatures. Do not store or place flammable materials near lamp.
11. Do not use this equipment for other than intended use.
12. Servicing of this equipment should be performed by qualified service personnel.

SAVE THESE INSTRUCTIONS

**31 Waterloo Avenue • Berwin • PA 19312 U•S•A
Telephone: (610) 647-8200 • Fax: (610) 296-8952**

BACKBOX INSTALLATION

DO NOT INSTALL SPLICE BOX COVER INTO BACKBOX UNTIL WIRING IS COMPLETE

BAR HANGERS

(4) BAR HANGER

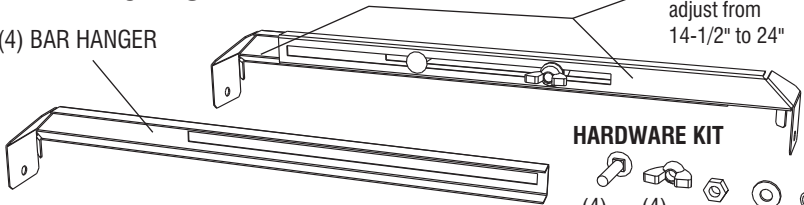

Bar Hangers telescope when assembled adjust from 14-1/2" to 24"

HARDWARE KIT

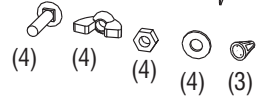

ROUGH-IN CEILING AND WALL MOUNT

SUPPORTING MEMBERS MUST BE ABLE TO SUPPORT A LOAD OF AT LEAST 25 LBS.

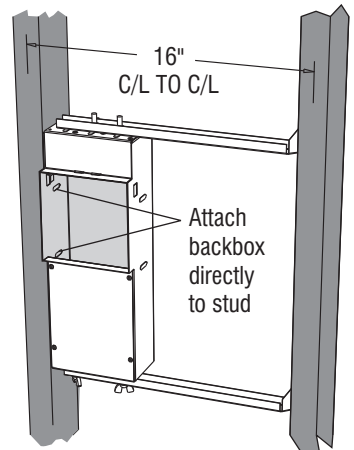
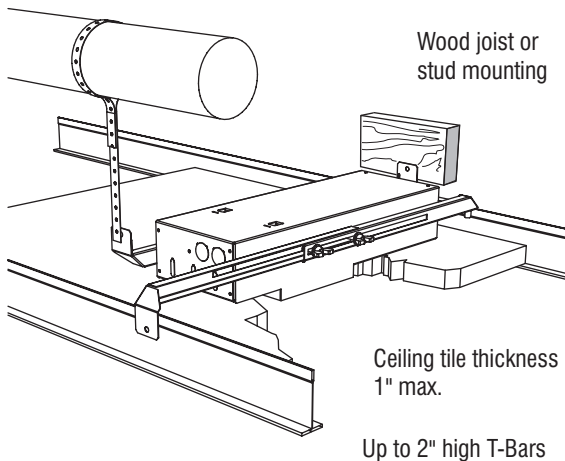

WALL MOUNT

Remove appropriate mounting knockouts on top, bottom or sides of backbox. Attach Bar Hangers to backbox using carriage bolts and wing nuts supplied. Wing nuts should be outside of backbox. If height adjustment from inside of backbox is required use hex nuts.

Using hardware supplied by others, attach to wood studs or joists with screws or nails, attach to metal studs with sheet metal screws with a minimum pullout rating of 25 lbs. Hanger bars will rest directly on drop ceiling T-Bars and can be secured by screws or wire (supplied by others). **UNIT IS APPROVED FOR TYPE IC INSTALLATION.**

Align backbox so lamphead opening is flush, or slightly behind inner surface of ceiling or wall.

CLOSE-IN CEILING AND WALL MOUNT

DRY WALL:

Cutout hole in ceiling material should be 5-1/4" high by 5-1/2" wide. Align backbox so lamphead opening is flush, or slightly behind inner ceiling or wall surface.

WET WALL:

Plaster flush up against lamphead opening.

5-1/4" high
5-1/2" wide
opening

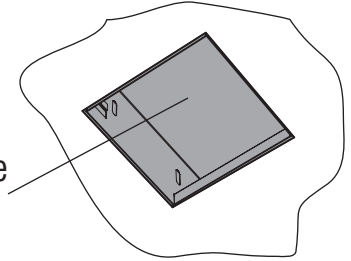

WIRING INSTRUCTIONS

DE-ENERGIZE BRANCH CIRCUIT AT BREAKER PANEL

Select and remove desired knockout(s) for AC power input with at least 6" of AC power leads extending into backbox. Secure cable with approved wire clamp and make connections using wire nuts supplied. Connect wires per local codes. Connect to transformer as follows:

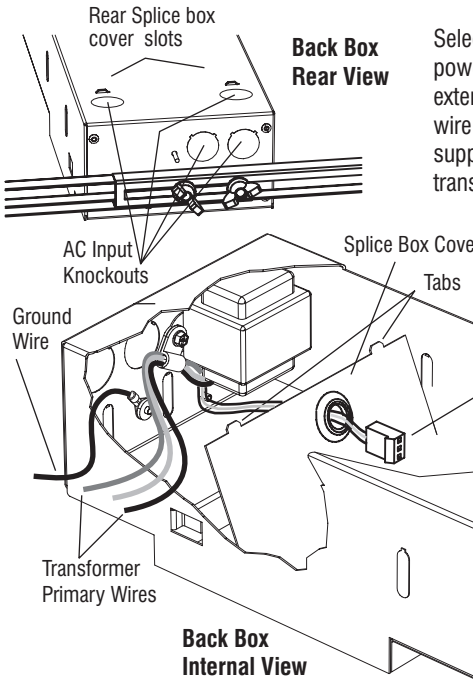

BLACK Lead for **120V** or
ORANGE Lead for **277V**
(CAP UNUSED LEAD)

WHITE Lead for **Neutral**

Connect **GREEN/YELLOW** Lead for
GROUND. Dress AC and Ground
wires down to bottom of backbox.

**DO NOT REAPPLY POWER
UNTIL FINAL SETUP**

INSTALL SPLICE BOX COVER

Feed transformer secondary cable (with connector) through hole in splice box cover and insert tabs into slots on the rear of the back box. Snap front tabs into slots on the top, front flange of the backbox.

BATTERY INSTALLATION

THIS PRODUCT IS SUPPLIED WITH A CHOICE OF 2 TYPES OF BATTERY SOURCES:
SEALED LEAD CALCIUM (LC) - NICKEL CADMIUM (Ni-Cd)

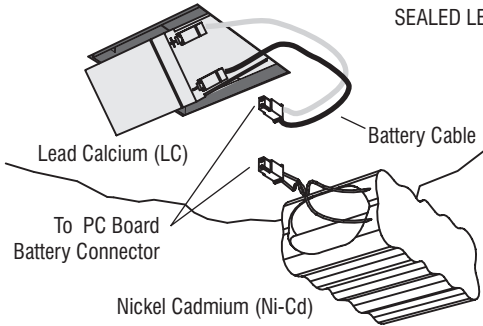

Attach Battery Cable to LC Battery ensuring that proper polarity is observed.

Insert Battery (**TERMINALS OR CONNECTORS FACING OUT**) through Lamphead opening. Allow Transformer Cable to extend out through Lamphead opening.

NOTE: Disconnected Battery must be recharged within 120 days.

LAMPHEAD INSTALLATION

Connect 2 pin Battery Cable first, then 3 pin Transformer Cable to matching sockets on Printed Circuit Board. **BATTERY CABLE, WITH BATTERIES CONNECTED, MUST BE ATTACHED BEFORE AC POWER IS APPLIED.**

NOTE: Once Battery is connected, unit must be energized within 30 days.

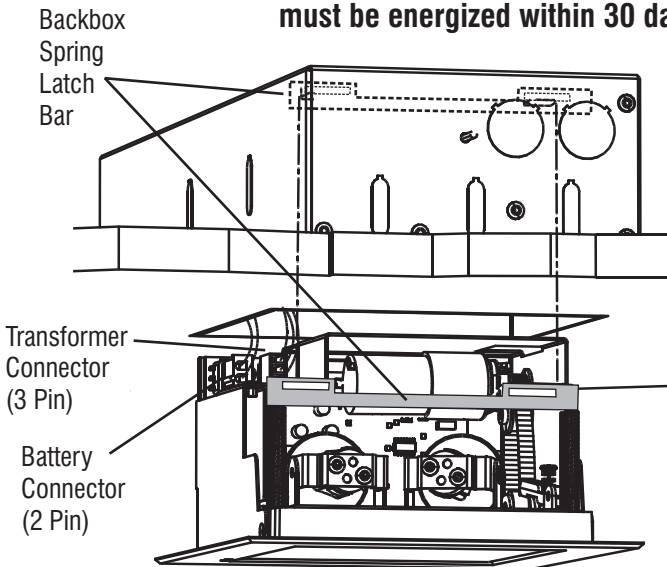

Install lamphed by first locating in place in Backbox opening.

With pivoting door held open, insert Phillips screwdriver tip into center hole in Spring Latch Bar, push down and forward to engage bar under two formed latch tabs in rear of Backbox.

Transformer secondary cable must be trapped behind Latch Bar to prevent interference with pivoting door.

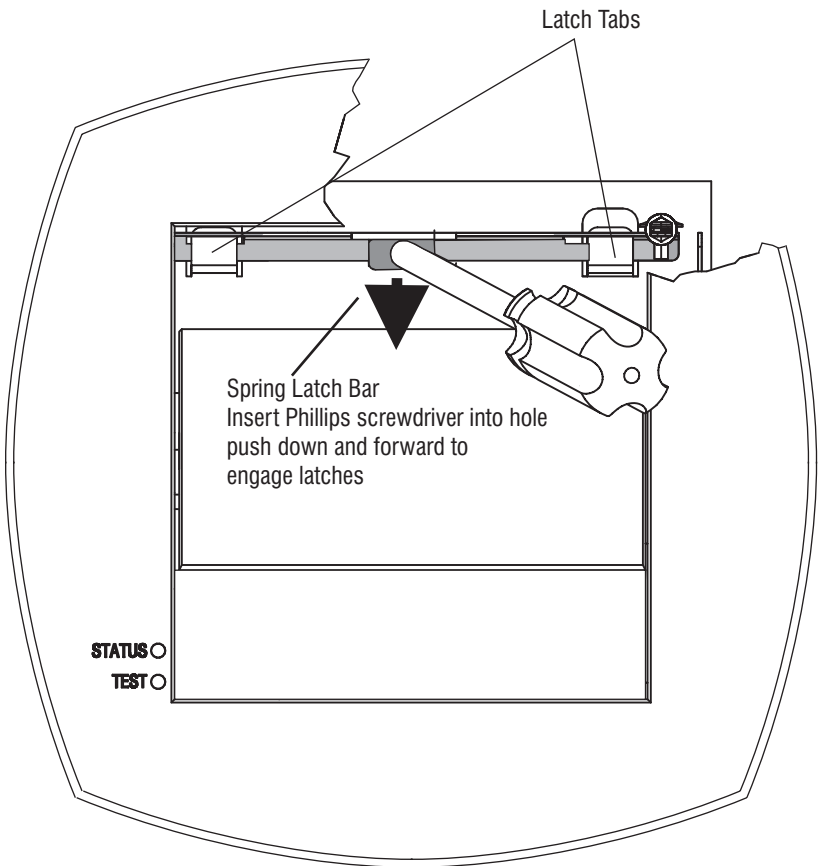

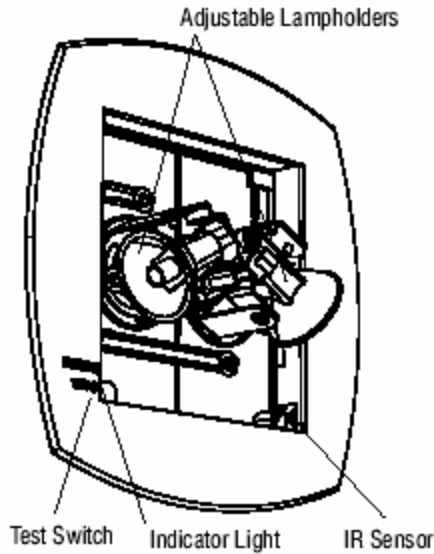

UNIT WITH DOOR OPEN

LAMP ADJUSTMENT

This Fully Recessed Emergency Light has 2 adjustable lamp holders mounted on the moveable door, with full aiming capability providing optimum lighting patterns.

ON-SITE PAINTING

The door and frame has been factory painted. If a new finish is applied, extreme care should be taken that a seal is not formed between the door and frame, which may hinder the free operation of the door mechanism.

If the finish is sprayed on, we suggest that a thin cardboard or plastic strip be inserted between the door and frame to prevent a paint seal. The indicator light and test switch holes should also be masked.

After the new finish is applied, a sharp edge such as a single edge razor or utility knife should be inserted a maximum of 1/4 inch into the opening between the door and frame, and run around the door to ensure no seal is formed.

SETUP AND OPERATION

REAPPLY POWER AND NOTIFY THE AUTHORITY HAVING JURISDICTION.

ALLOW BATTERIES TO CHARGE FOR AT LEAST 72 HOURS BEFORE OPERATING UNIT.

STATUS - On units without SelfTesting / SelfDiagnostic option, the "STATUS" indicator will show "RED" when AC power is applied to the unit. Flashing of the "STATUS" indicator indicates either a defective or disconnected battery or the battery requires further charge. On units equipped with Self-Testing / Self-Diagnostic option, see following pages for instructions.

TEST - The "TEST SWITCH" is used to simulate failure of AC power. It can be activated with a paper clip.

INFRA RED REMOTE TESTING - To activate TRANSMITTER, remove tab from back of device. The "IR REMOTE TESTING TRANSMITTER" can activate the unit up to 50 feet. By aiming TRANSMITTER at face of unit and pushing either "30 SECOND" or "90 MINUTE" button for 1 second, AC power failure will be simulated for the selected duration. The test can be cancelled by pushing button again.

TIME DELAY - A 15 minute time delay is available as a factory option. This option will keep the unit operating on battery backup for 15 minutes after power is restored. This feature allows HID lamps to warm up before the emergency lights are extinguished.

CCEA APPROVAL - Approval for CCEA City of Chicago Environmental Airspace is available as a factory option.

SELF-TESTING / SELF-DIAGNOSTICS

This unit meets the requirements of NFPA 101 for Periodic Testing of Emergency Lighting Equipment. It provides visual indication of unit malfunctions including:

Battery Fault
Charger Fault
Transfer Fault
Lamp Fault
Door Fault

SELF-TEST

An automatic self-test and diagnostic function will be performed every 28 days. A load test will be performed for 30 seconds checking for a lamp, battery or transfer fault. On every fourth test, the load test will follow a door function test, during which the door will open for approximately 1 second and then close, without the lamps turning on. This automatic self-test and diagnostic function will be performed only if the battery is fully charged. If not, the test will automatically reschedule. The charger function is monitored continuously.

USER-TEST

A manual USER-TEST can be performed for 30 seconds or 90 minutes. By pushing the "TEST" Switch for 1 second, the door will open and the lamps will illuminate for 30 seconds. If the "STATUS" indicator shows GREEN indicating a fully charged Battery and the Switch is pushed for 4 seconds, the door will open and the lamps will illuminate for 90 minutes. If the Battery is not fully charged, the 30 second test will run.

In either mode, the USER-TEST can be cancelled by pushing and holding the "TEST" Switch for 1 second after the lamps come on.

LAMP LOAD LEARN

The self-diagnostic system "learns" the lamp load during the first test. Subsequent tests compare the measured lamp load during the test to the learned lamp load values.

CLEARING FAILURE INDICATIONS

Failure indications can be cleared by correcting the indicated fault and pushing and holding the "TEST" Switch for 1 second.

STATUS INDICATIONS

Status indications for the self-testing / self-diagnostic system are shown on the following page.

STATUS INDICATIONS

STATUS DISPLAY	FUNCTION	ACTION
Continuous Green	Battery in Float / Trickle Charge	None
Continuous Red	Battery High Charging	Wait for Green Status
Flashing Green	In Test Mode	Wait for Test to Complete
Alternate Red and Green	Insufficient Charge For User Test	Wait for Adequate Charge*
Red One Blink ON / Pause	Transfer System Failure	Factory Service
Red Two Blinks ON / Pause	Battery Failure	Check Connections / Replace Battery
Red Three Blinks ON / Pause	Charger Failure	Factory Service
Red Four Blinks ON / Pause	Door Failure	Check for Paint Seal
Red Five Blinks ON / Pause	Lamp Failure	Replace Lamp

* For 90 minute User Tests, wait for full charge.
For 30 second User Tests, try again after an hour of charging.

MAINTENANCE

REMOVAL OF SPLICE BOX COVER - Splice Box Cover can be removed from backbox by prying forward the top, front flange of the backbox with a flat blade screwdriver.

LAMP REPLACEMENT - Door may be opened manually. Grasp socket so aiming position is not disturbed. Be sure replacement lamp is totally seated in socket. Refer to replacement lamp part number. Use only specified replacement lamps.

BATTERY - The battery supplied in this unit requires no maintenance. However, it should be periodically tested (see TEST or IR Remote Testing) and replaced whenever it will no longer operate the emergency lamps for the durations specified. Replace using the BATTERY INSTALLATION procedure. Refer to replacement battery part number. Use only specified replacement batteries.

Used batteries may not be disposed of in the municipal solid waste stream. Arrangements for recycling Sealed Lead Calcium batteries can be made at 1-323-278-1900. For information on local recycling drop off points for Nickel Cadmium batteries, call 1-800-BATTERY.