

Installation guide

Philips EvoBase LED Retrofit KIT G1 2'x4' and 2'x2'



⚠ WARNING

FAILURE TO FOLLOW TI-IESE INSTRUCTIONS AND WARNINGS MAY RESULT IN SERIOUS INJURY OR SIGNIFICANT PROPERTY DAMAGE.

For your protection, carefully read these warnings and instructions in their entirety before installing or maintaining this equipment. These instructions do not attempt to cover all installation and maintenance situations. If you do not understand these instructions or if additional information is required, contact your local Philips representative. Retain these instructions for maintenance reference.

⚠ WARNING

RISK OF FIRE OR ELECTRIC SHOCK

The EvoBase must be installed and maintained by a professional electrician in accordance with the applicable federal, state and local laws, regulations and electrical codes, and the installation instructions provided in this document. This professional should be familiar with the construction and operation of this product and any hazards involved. If not qualified, do not attempt installation. Contact a qualified electrician.

⚠ WARNING

RISK OF FIRE, ELECTRIC SHOCK OR PERSONAL INJURY

Do not install in a damaged fixture.

Install the EvoBase only in a minimum troffer depth of 3". Before installation, turn power off.

⚠ WARNING

RISK OF PERSONAL INJURY

This equipment may have sharp edges. Wear gloves to prevent cuts or abrasions when removing from carton, handling and maintaining this equipment.

⚠ WARNING

RISK OF FIRE OR ELECTRIC SHOCK

To prevent wiring damage or abrasion, do not expose wiring to edges of sheet metal or other sharp objects.

⚠ WARNING

RISK OF FIRE OR ELECTRIC SHOCK

Luminaire wiring and electrical parts may be damaged when drilling for installation of LED retrofit kit. Check for enclosed wiring and components.

Notice

Do not use abrasive materials, glass cleaners or other solvents on cover plate or lens. To clean the faceplate, use a mild soap solution.

Do not expose the product to substances and /or materials containing sulphur, chlorine or other halogen compounds and to chemicals mentioned in below table.

Category	Chemical Name
Solvents	Toluene, xylene, benzene, chloromethane, chloroform, ethyl acetate, butyl acetate, acetone, MEK, MIBK
Acid	HCl, H ₂ SO ₄ , HNO ₃
Alkali	KOH, NaOH, LiOH, Ca(OH) ₂
Oil	Diesel oil, petroleum, hydro carbons

Caution

This kit is designed for permanent installation in ordinary (Non-Hazardous) locations in accordance with the National Electrical Code and all applicable local codes. Do not use in areas of limited ventilation or in high ambient enclosures.

Caution

Do not make or alter any open holes in an enclosure of wiring or electrical components during kit installation except if specifically mentioned in these installation guide.

Notice

Handle components with care. Do not drop, slide or scratch any of the components to prevent visual damage to the product, loss of functionality or difficulties during installation.

PHILIPS

Installation Philips EvoBase LED Retrofit KIT 2'x4' and 2'x2'

Host lighting fixture

The Philips EvoBase is designed for installation in a wide variety of 2'x4' and 2'x2' indoor fluorescent based fixtures in horizontal applications.

- Install the Philips EvoBase in fluorescent based host lighting fixtures only with a minimum depth of 3".
- Due to the wide variety in troffers and ceiling grids, it is recommended that the installer does a test install before commencing a renovation.
- Please, verify voltage on the Philips EvoBase product label matches the mains voltage.

Set contains

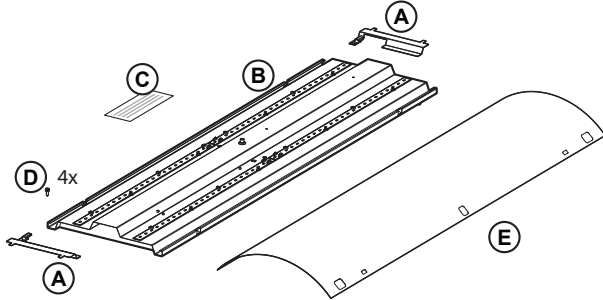

- A Brackets (2: Left & Right) D Screws
 B Panel E Diffuser
 C Troffer Label

Tools required

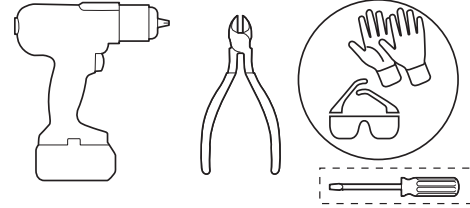

⚠️ WARNING

RISK OF FIRE, ELECTRIC SHOCK
OR PERSONAL INJURY

Before installation, turn power off.

Installation Philips Bodine 50344I (Optional)

For installation of the Philips Bodine 50344I Emergency LED Driver, please see the emergency driver installation section from this EvoBase manual

Remove host fixture contents

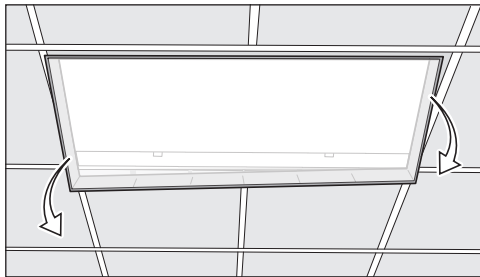

1. Turn power off and take out original cover.

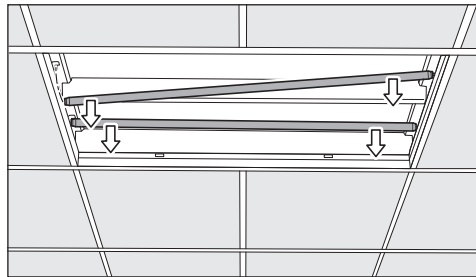

2. Take out TL tubes.

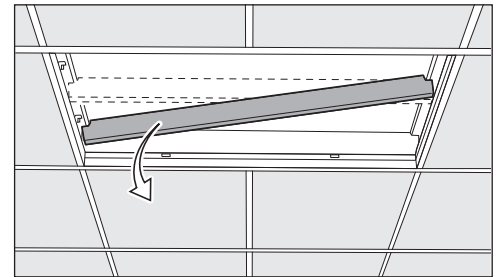

3. Remove belly pan.

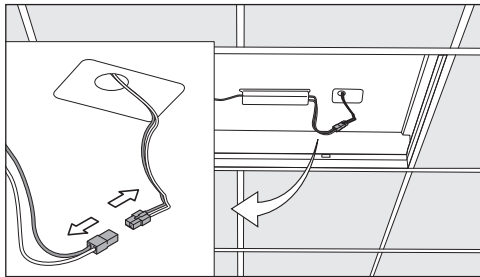

4. Disconnect from mains and remove host fixture ballast.

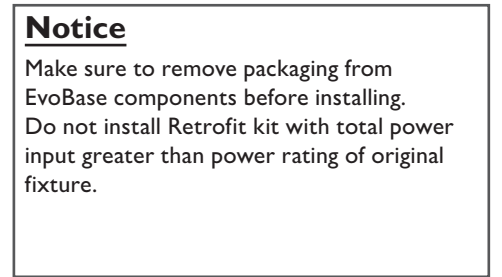
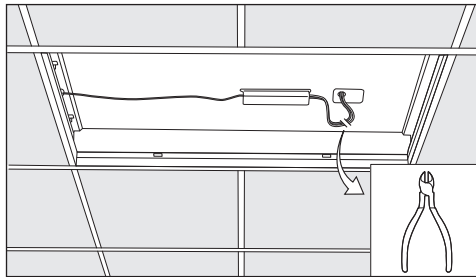

Installation Brackets (A)

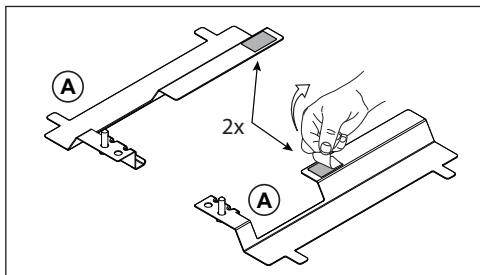

5. Remove the double sided tape backing.

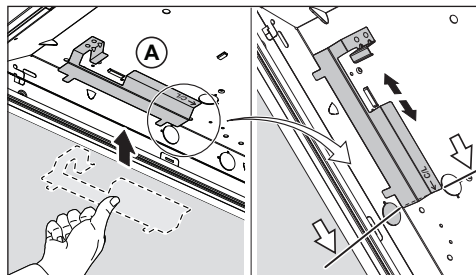

6. Fix the Brackets by sticking against the mounting face. Align the arrow on the Bracket with the virtual center line of the troffer.

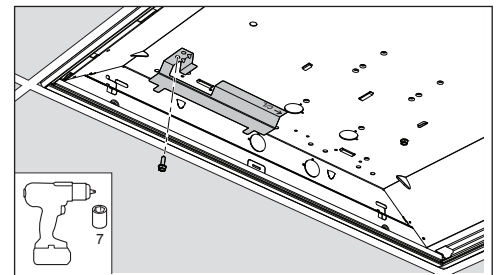

7. Affix each Bracket with self-drilling screw, using either one of two available holes in the Bracket.

Installation Panel (B)

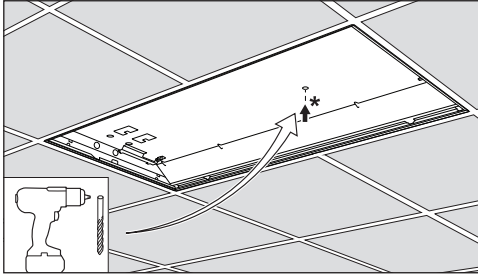

8a. If no existing Ground Wire is accessible, please, predrill a hole in host fixture for use of Ground Wire, attached to Retrofit Kit.

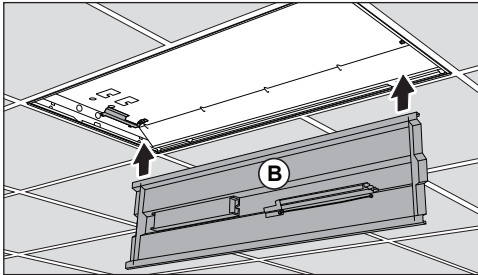

8b. Hang panel B on Bracket Hooks.

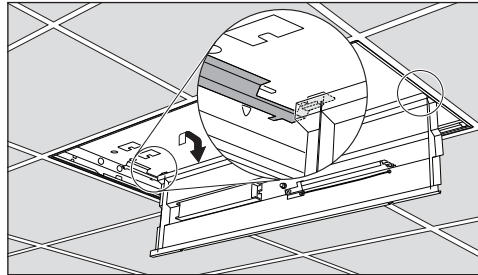

⚠ WARNING

RISK OF PERSONAL INJURY

While installing and closing the panel (B) make sure the electrical wiring is not pinched between panels.

Notice

Do not touch the LEDs with hands or tooling! Touching LEDs can lead to failure of the product.

Ground connection (Situation 1 - 2)

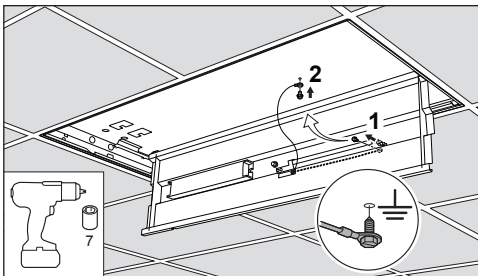

9a. Secure grounding.
For safety there should be no drilling while Module hangs on Bracket Hooks!

Notice

If using dimming control leads refer to section 15a.

⚠ WARNING

RISK OF PERSONAL INJURY

Proper grounding of EvoBase metal parts is required to ensure personal safety.

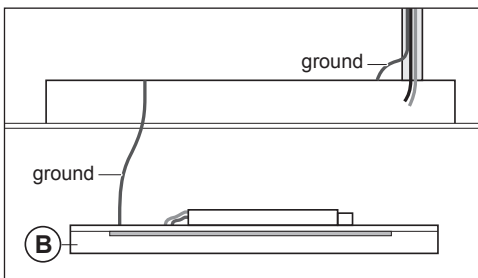

Situation 1 Grounding:
Screw grounding cable from Led Panel (B) to predrilled hole in original troffer if host fixture ground connection is made through host fixture.

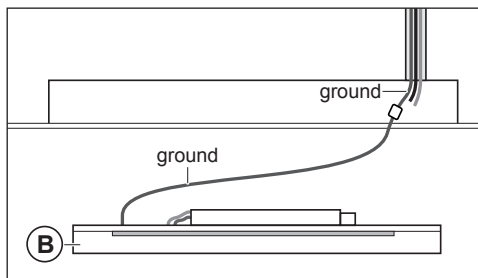

Situation 2 Grounding:
Connect to the incoming ground lead from conduit.

Notice

Make new electrical connections to mains by employing applicable connectors in accordance with the applicable federal, state and local laws, regulations and electrical codes.

Mains connection

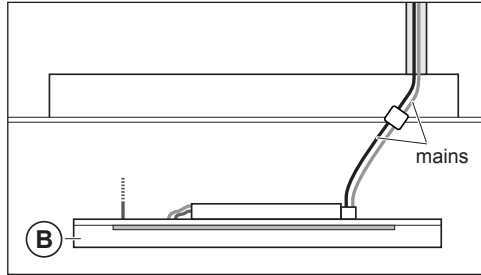

10. Connect main cables and hide connected wires behind LED Panel (B).

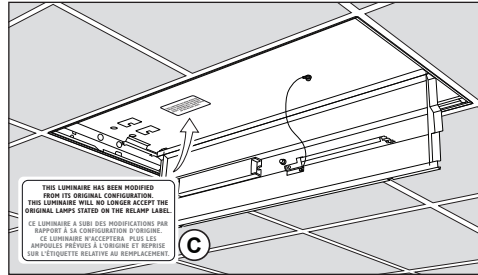

11. Place Troffer Label (C) inside original troffer.

Notice

It is imperative to use the retrofit warning sticker, included with the product in order to alert the end user that this luminaire will no longer operate on the originally intended lamps.

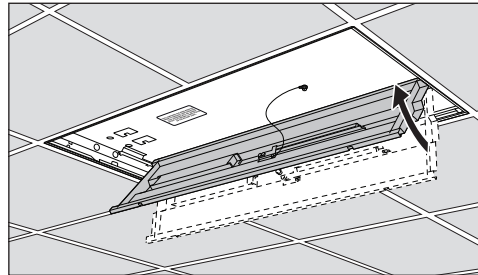
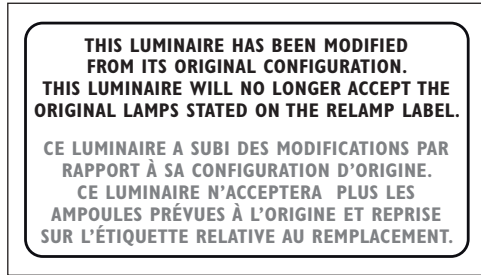

12. Close panel B.

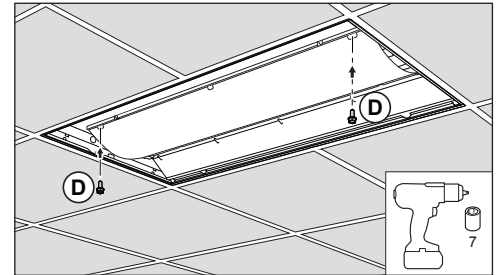

13. Fasten the self-drilling screws (2x). For 2x4ft design an additional self-drilling screw can be used in the center if preferred.

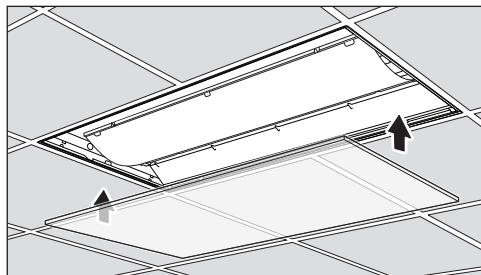

14. Reinstall original cover.

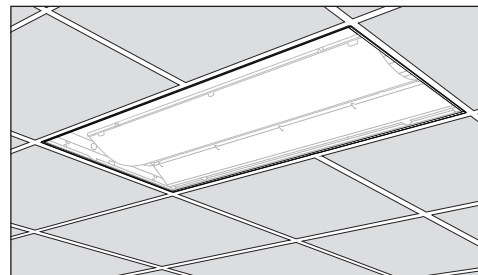

Connection 0-10V and MK10 dimmer (Optional)

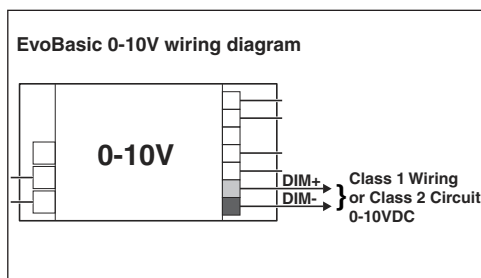

15a. Optional: For connection EvoBase 0-10V input, use indicated connections on the driver.

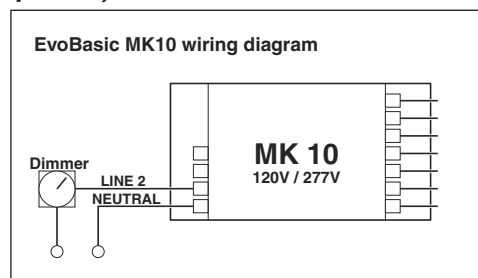

15b. Optional: For connection a dimmer to the EvoBase Mark 10, use indicated connections on the driver.

Notice

Use 18 AWG Solid Copper Wire Rated $\geq 300V$. Strip Wire 3/8"

In case the EvoBase MK10 277V is installed in combination with a dimmer, use a minimum of 2 EvoBases MK10 277V per dimmer.



© Philips Lighting Holding B.V. 2016.
All rights reserved
A Division of Philips Lighting North America Corporation.
Printed in USA 8/13

www.philips.com

20160119

Philips Lighting North America Corporation
200 Franklin Square Drive
Somerset, NJ 08873
1-800-555-0050
000000000000

Philips Lighting Canada Ltd.
281 Hillmount Road, Markham,
Ontario
Canada L6C 2S3
1-800-555-0050

Installation Philips Bodine 50344I Emergency LED driver

Initial installation Philips Bodine 50344I Emergency LED driver (Sold separately)

If the Philips Bodine 50344I Emergency LED Driver is to be installed into the EvoBase retrofit fixture, please follow these instructions and the instructions provided with the Emergency driver.

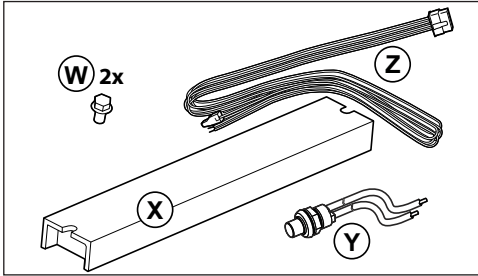

Components: Screws (W), Emergency LED driver (X), Test switch (Y) Wiring harness (Z).

WARNING

RISK OF PERSONAL INJURY

Ensure all warning and cautionary markings given in the Philips Bodine 50344I installation instructions are heeded.

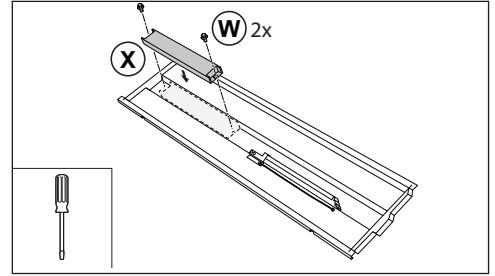

1. Secure 50344I (X) to the back side of LED Panel (B) using two screws (W).

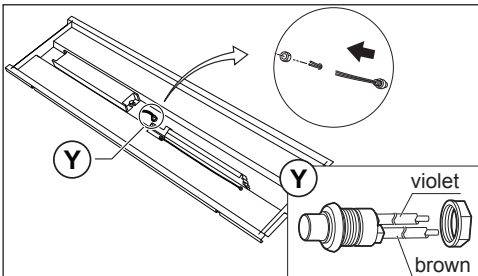

2. Install the test switch by first removing the punch out feature and creating a hole for the Test switch (Y). Feed the violet and brown wires through this 1/2" hole and hand tighten the plastic nut included with the test switch/LED combo. Add connect from test switch to wiring harness (Z) (violet - violet, brown - brown).

Notice

Ensure an un-switched hot circuit is available to the fixture. This is required for proper emergency fixture operation.

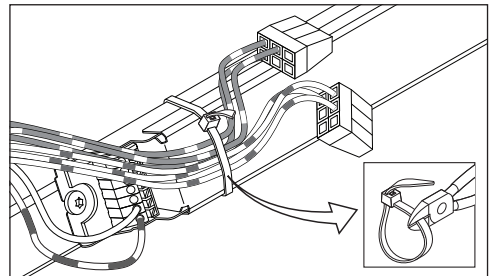

3. Remove tie-wrap.

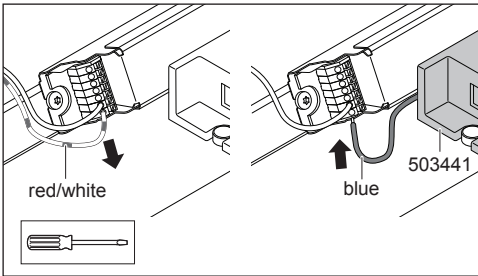

4. Disconnect the red/white single wire from the EvoBase driver. Replace it with the blue output wire from the 50344I (Z). Place a wire nut over the original red/white wire for proper isolation.

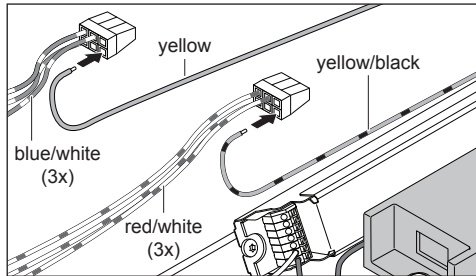

5. Connect the yellow output wire from the 50344I to the EvoBase blue/white wire connection block and the yellow/black output wire from the 50344I (Z) to the EvoBase red/white wire connection block.

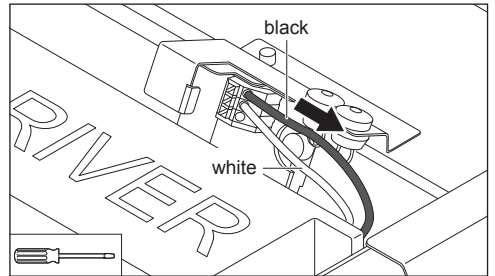

6. Disconnect black wire and insert white/black wire (Z) in the EvoBase driver.

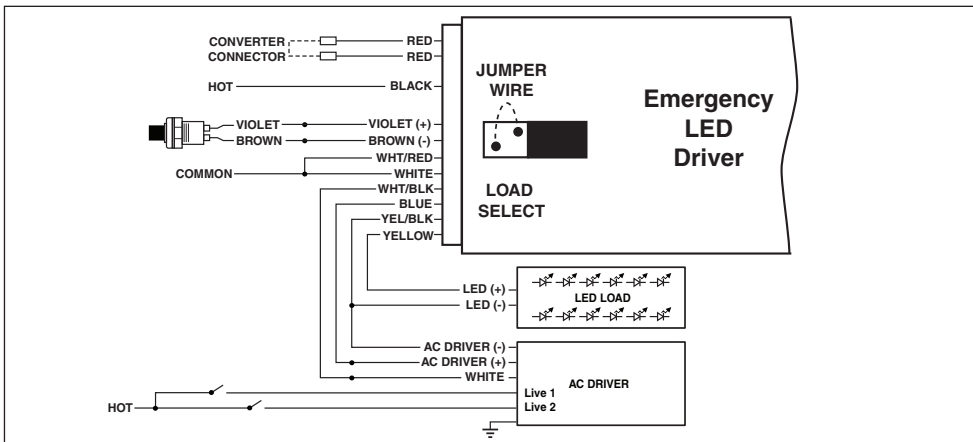

7. Connect the input wiring as per the 50344I wiring diagram, ensuring switched hot, un-switched hot, and neutral are all connected to the appropriate 50344I wires.