

luna[®] led

FLUL 2x2 | 2x4



FOCAL POINT[®]

⚠ AVOID ALL CONTACT WITH LED SURFACE, LEDs ARE EASILY DAMAGED!

FOCAL POINT

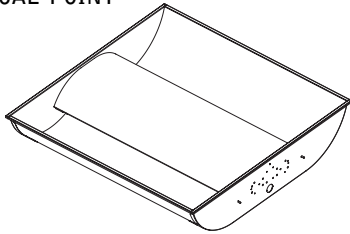

KEY



POWER OFF

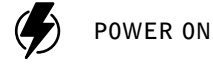

POWER ON



ATTENTION

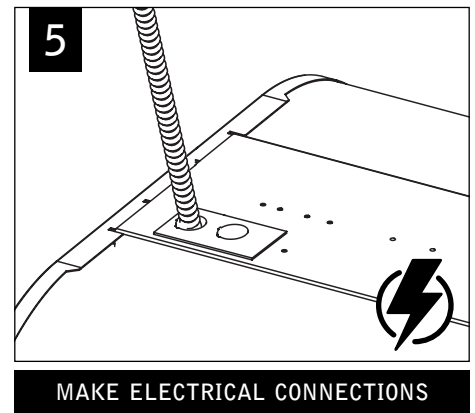
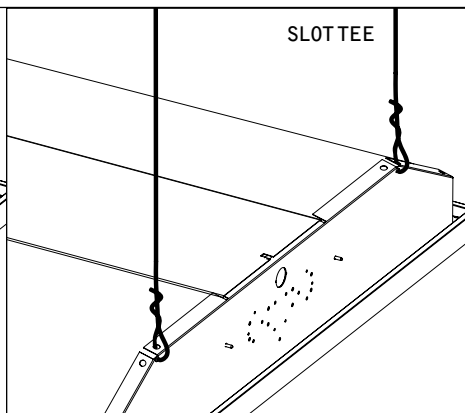
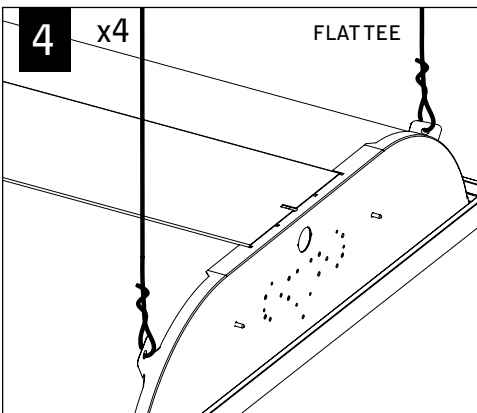
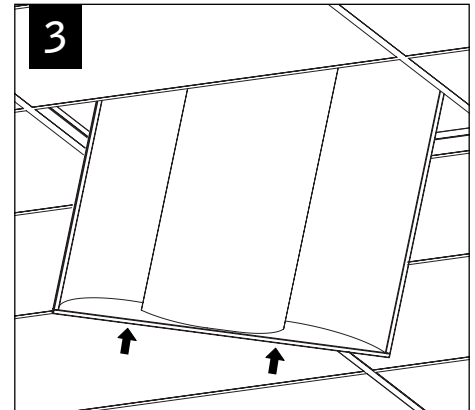
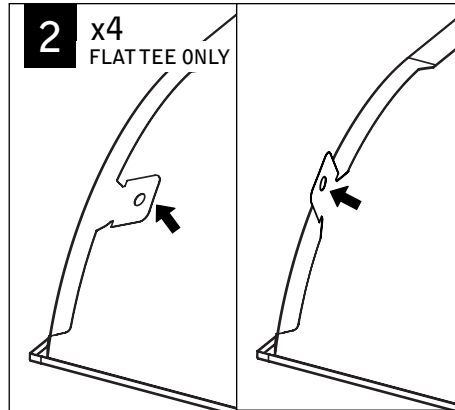
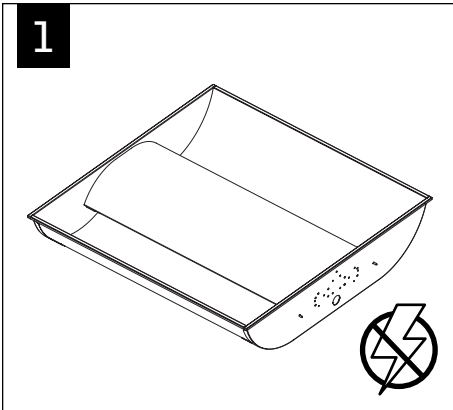

DRYWALL INSTALLATION

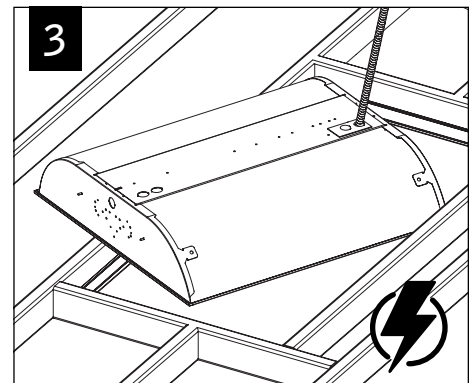
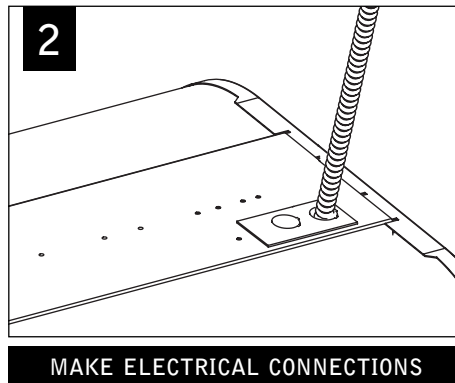
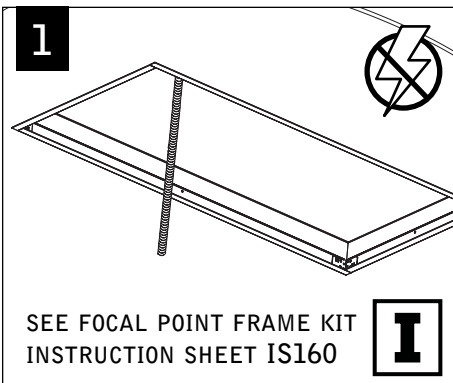

Luminaires must be installed by a qualified electrician (check with local and national codes for proper installation).
To prevent electrical shock, disconnect electrical supply before installation or servicing.

SERVICE

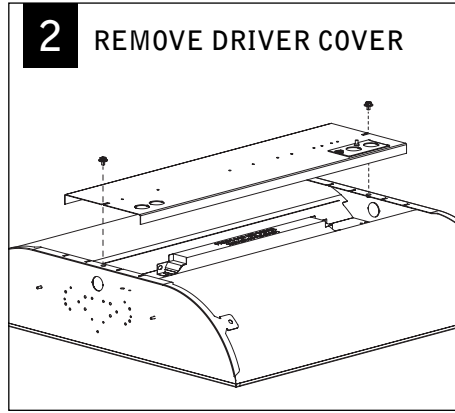
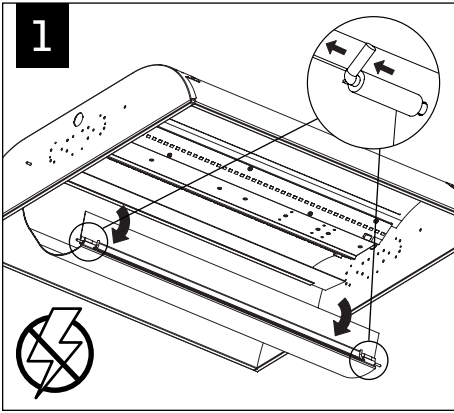

0-10V DIMMING & NON-DIMMING STANDARD WIRING

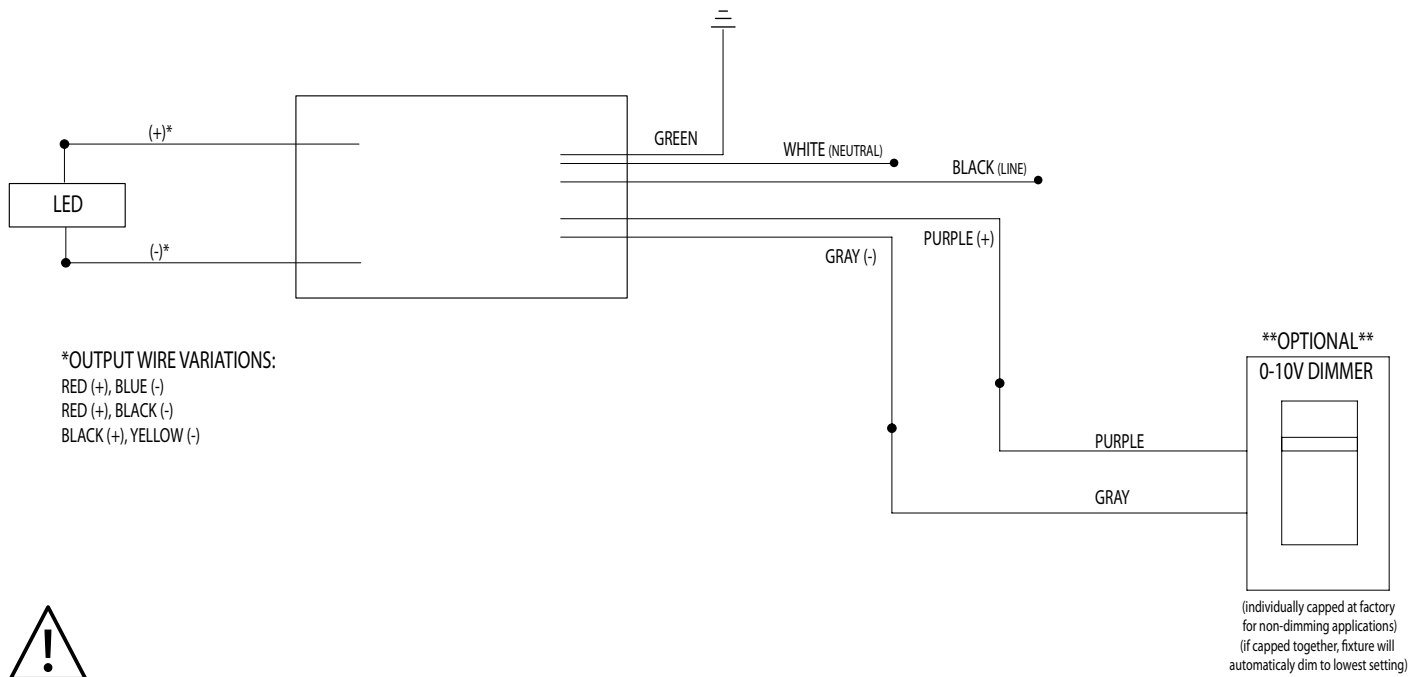

REFERENCE DRIVER MANUFACTURER'S SPEC SHEETS FOR DRIVER SPECIFIC WIRING DIAGRAMS.
 EMERGENCY LUMINAIRES WIRED ACCORDING TO BATTERY MANUFACTURER'S INSTRUCTIONS.

Contractor is responsible for adequately reinforcing walls and/or ceilings to support fixture weight. Focal Point, LLC accepts no responsibility for inadequately reinforced walls and/or ceilings. The information contained in this drawing is the sole property of Focal Point, LLC. Any reproduction in part or whole without the written permission of Focal Point, LLC is prohibited. US Patents: D605,340; D605,341; D605,342; D608,490; D620,190S. European Patents: 001596313-0001, 001596313-0002, 001596313-0003, 001596313-0004, 001596313-0005, 001596313-0006, 001596313-0007, 001596313-0008, 001596313-0009. Canadian Patents: 130763, 130764, 130765, 130766.