

# Pulse Start Metal Halide 1000 Watt Lamp (Clear)

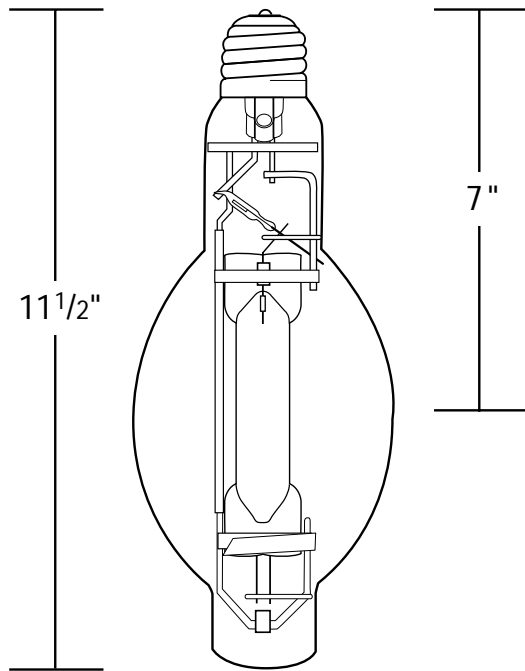

## ■ Ordering Information

Ordering Code	MS1000/BU/BT37/PS
ANSI Designation	M141/E
Product Number	360198
Description	Pulse Start Metal Halide
Package Quantity	6

## ■ Physical Characteristics

Bulb Size	BT-37
Bulb Finish	Clear
Base (Nickel Plated Brass)	Mogul Screw
Max. Overall Length (MOL)	11 1/2" (292mm)
Light Center Length (LCL)	7.0" (178mm)
Arc Length	3.425" (87mm)
Arc Tube Material	Quartz
Max. Permissible Bulb Temp.	430° C (806° F)
Max. Permissible Base Temp.	210° C (410° F)
Max. Bulb to Base Eccentricity	3°
Max. Arc Tube to Base Eccentricity	3°

## ■ Operating Characteristics (Photometric)

Rated Initial Lumens	120,000
Mean Lumens, Approx.	96,000
Rated Average Life, Hours	15,000
Correlated Color Temp. (CCT)	3800K
CIE Chromaticity Approx.	x-.400, y-.400
Color Rendering Index (CRI)	65
Efficacy (lpw)	120

## ■ Operating Position

Base Up ± 15°-Enclosed Luminaires Only

Note: Pulse Start Metal Halide is Designed for Operation on Only Approved Ballasts with Metal Halide Pulse Ignitors.

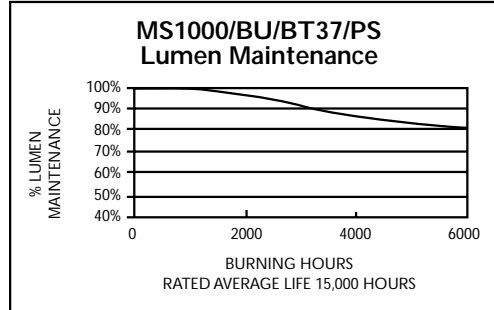

Let's make things better.



**PHILIPS**

## Pulse Start Metal Halide 1000 Watt Lamp (Clear)

### Electrical Data (Subject to change without notice)

---

Lamp Watts (Nominal) . . . . .	1000
Lamp Operating Voltage (rms) (Nominal) . . . . .	263
Initial Lamp Voltage Range (rms) . . . . .	238–288
Lamp Operating Current (Amps) (rms) (Nominal) . . . . .	4.1
Lamp Current Crest Factor (Maximum) . . . . .	1.6
Warm-up Time to 90% of Output . . . . .	2 Minutes
Re-strike Time for Hot Lamp . . . . .	7 Minutes
Ballast Type . . . . .	ANSI M141/E
Ballast Open Circuit Voltage (Minimum) . . . . .	390 RMS Min.
Pulse Peak Volts . . . . .	3000 Min., 4000 Max.
Pulse Width @ 90% Peak (micro sec) . . . . .	2.2
Pulse Repetition Rate (Minimum) . . . . .	1x1/2cycle
Minimum Operating Temperature . . . . .	-30° C
Advance Transformer Ballast Number . . . . .	71A6593

---

### Warnings, Cautions and Operating Instructions

“WARNING: These lamps can cause serious skin burn and eye inflammation from short wave ultraviolet radiation if outer envelope of the lamp is broken or punctured. Do not use where people will remain for more than a few minutes unless adequate shielding or other safety precautions are used. Certain lamps that will automatically extinguish when the outer envelope is broken or punctured are commercially available.” This lamp complies with FDA radiation performance standard 21 CFR subchapter J. (USA: 21CFR 1040.30 Canada: SOR/DORS/80-381)

If the outer bulb is broken or punctured, turn off at once and replace the lamp to avoid possible injury from hazardous short wave ultraviolet radiation. Do not scratch the outer bulb or subject it to pressure as this could cause the outer bulb to crack or shatter. A partial vacuum in the outer bulb may cause glass to fly if the envelope is struck.

WARNING: The arc-tube of metal halide lamps are designed to operate under high pressure and at temperatures up to 1000° C and can unexpectedly rupture due to internal or external factors such as a ballast failure or misapplication. If the arc-tube ruptures for any reason, the outer bulb may break and pieces of extremely hot glass might be discharged into the surrounding environment. If such a rupture were to happen, THERE IS A RISK OF PERSONAL INJURY, PROPERTY DAMAGE, BURNS AND FIRE.

Certain lamps that will retain all the glass particles should inner arc-tube rupture occur are commercially available from Philips Lighting Company.

RELAMP FIXTURES AT OR BEFORE THE END OF RATED LIFE. Allowing lamps to operate until they fail is not advised and may increase the possibility of inner arc tube rupture.

CAUTION: TO REDUCE THE RISK OF PERSONAL INJURY, PROPERTY DAMAGE, BURNS AND FIRE RESULTING FROM AN ARC-TUBE RUPTURE THE FOLLOWING LAMP OPERATING INSTRUCTIONS MUST BE FOLLOWED.

### Lamp Operating Instructions

- 1) Turn off lamps at least once a week for at least 15 minutes in systems which are operating on a continuous basis (24 hours/day-7days/week). FAILURE TO TURN OFF LAMPS FOR THE MINIMUM RECOMMENDED TIME MAY INCREASE THE POSSIBILITY OF AN INNER ARC-TUBE RUPTURE.
- 2) RELAMP FIXTURES AT OR BEFORE THE END OF RATED LIFE. Allowing lamps to operate until they fail is not advised and may increase the possibility of inner arc tube rupture.
- 3) Use only in an enclosed fixture capable of withstanding particles of glass having temperatures up to 1000° C.
- 4) Before lamp installation/replacement, shut power off and allow lamp and fixture to cool to avoid electrical shock and potential burn hazards.
- 5) Use only auxiliary equipment meeting Philips and/or ANSI standards. Use within voltage limits recommended by ballast manufacturer.
  - A. Operate lamp only within specified limits of operation.
  - B. For total supply load refer to ballast manufacturers electrical data.
  - C. All Pulse Start mogul based lamps require a socket rated to withstand a 4000 volt pulse.
- 6) Periodically inspect the outer envelope. Replace any lamps that show scratches, cracks or damage.
- 7) If a lamp bulb support is used, be sure to insulate the support electrically to avoid possible decomposition of the bulb glass.
- 8) Protect lamp base, socket and wiring against moisture, corrosive atmospheres and excessive heat.
- 9) Time should be allowed for lamps to stabilize in color when turned on for the first time. This may require several hours of operation, with more than one start. Lamp color is also subject to change under conditions of excess vibration or shock, and color appearance may vary between individual lamps.
- 10) Lamps may require 2 to 4 minutes to re-light if there is a power interruption.
- 11) Take care in handling and disposing of lamps. If an arc tube is broken, avoid skin contact with any of the contents or fragments.
- 12) Use this lamp only in fixtures that contain a Pulse Start metal halide ballast and are specifically designed for use with Pulse Start metal halide lamps.