

CS8275



UPC Code: 07847732612

Country of Origin: Mexico - *Eligible for ARRA funded projects > \$7,443,000

Configuration:



Locking Wiring Devices

Brand Features

Leviton's Black & White 50 Amp, Non-NEMA line of industrial grade locking blade devices feature rugged construction that resists impact, sunlight, chemicals and rough use. All contacts and blades are solid one-piece construction for superior conductivity. Corrosion resistant versions feature nickel plated contacts and blades, plus stainless steel shrouds and screws. The ergonomic, fluted-body design with radial gripping edge is ideal for gripping and pulling. The unique cord clamp accepts a wide range of cord sizes, providing a secure grip without damaging the cord. And, they are backed by a limited lifetime warranty.

Item Description

50 Amp, 250 Volt, Non-NEMA, 2P, 3W, Black & White Locking Flanged Inlet, California-Style, Industrial Grade, Grounding - GRAY METAL

Technical Information

Electrical Specifications

Grounding: Grounding

Amperage: 50 Amp

Voltage: 250 Volt

Pole: 2

Wire: 3

Dielectric Voltage: Withstands 2000V per UL498

Maximum Working Voltage: 250V as rated

Temperature Rise: Max 30°C temp rise at full-rated current after 150 cycles of OL at 150% rated DC current

Current Interrupting: Certified for current interrupting at full rated current

Environmental Specifications

Flammability: Rated V-2 per UL94

Operating Temperature: -40deg.C to 75deg.C (-40deg.F to 167deg.F)

Material Specifications

Face Module: Nylon

Body & Contract Carrier: Reinforced Nylon

Flanged Casing: Zinc Plated Steel

Inlet Blade: 0.100inch thick Brass

Terminal Block: 0.062inch thick Copper

Terminal Set Screw: SS 302/304

Ground Shunt: Bronze

Grounding Shunt Rivet: Brass

Color: Gray Metal

Mechanical Specifications

Terminal ID: X, W, Y, Z and Green for ground

Terminal Accom.: #10 min to #4max AWG Solid or Stranded Wire

Product ID: Ratings and Catalogue No. molded into face

Product Features

NEMA: Non-NEMA

Color: Gray Metal

Standards and Certifications

UL498: File E13399

CSA C22.2 No. 42: File 152105

NOM: 057

RoHS: Compliant

Warranty: Lifetime Limited

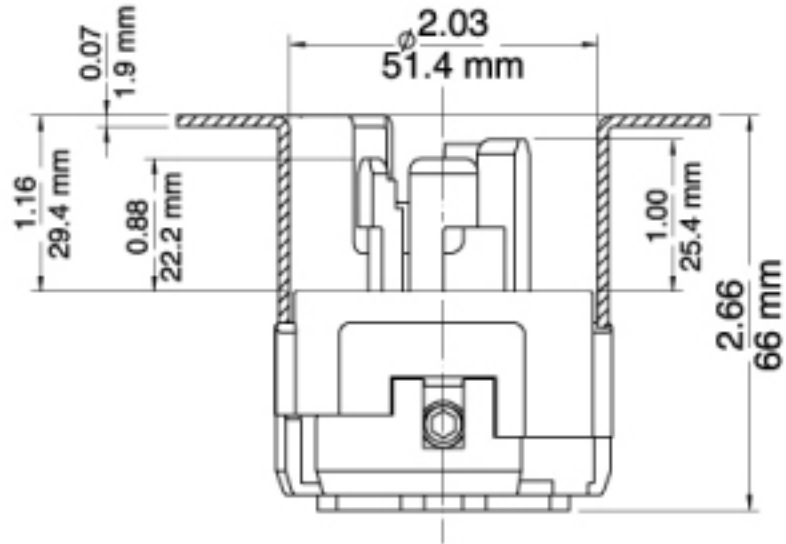
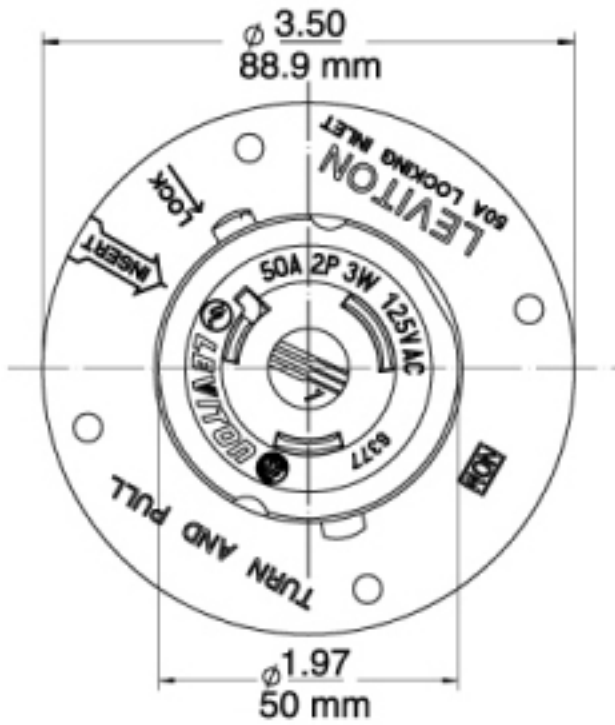

SPECIFICATION SUBMITTAL

JOB NAME:	CATALOG NUMBERS:	
<input type="text"/>	<input type="text"/>	<input type="text"/>
JOB NUMBER:	<input type="text"/>	<input type="text"/>

Leviton Manufacturing Co., Inc.
 201 North Service Road, Melville, NY 11747
 Telephone: 1-800-323-8920 · FAX: 1-800-832-9538 · Tech Line (8:30AM-7:30PM E.S.T. Monday-Friday): 1-800-824-3005

Leviton Manufacturing of Canada, Ltd.
 165 Hymus Boulevard, Pointe Claire, Quebec H9R 1E9 · Telephone: 1-800-469-7890 ·
 FAX: 1-800-824-3005 · www.leviton.com/canada

Leviton S. de R.L. de C.V.
 Lago Tana 43, Mexico DF, Mexico CP 11290 · Tel.: (+52)55-5082-1040 · FAX: (+52)5386-1797 · www.leviton.com.mx

Visit our Website at: www.leviton.com
 © 2012-2014 Leviton Manufacturing Co., Inc. All rights reserved. Subject to change without notice.



Leviton has a global presence.
 If you would like to know where your local Leviton office is located please go to: www.leviton.com/international/contacts/

**Buy American Compliant Logo -- The American Recovery And Reinvestment Act of 2009 ("ARRA") provides federal grants and loans for projects throughout the country. Section 1605 of the Act, named the "Buy American" provision, requires that certain materials and manufactured products used in projects funded by the Act be manufactured in the United States. The appearance of the Recovery Act Logo in relation to a Leviton product is only intended to reflect that such product may be used in an ARRA funded project. It does not mean that such product or Leviton is sponsored or endorsed by, or that Leviton receives funds from, the federal government or the Recovery Accountability and Transparency Board. Nothing in Leviton's use of the logo is intended to suggest anything regarding the requirements for funding under ARRA.*