

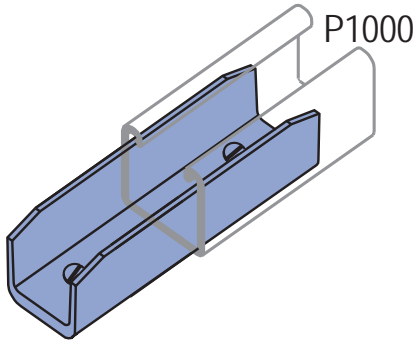



P2900

Wt/100 pcs: 20 Lbs (9.1 kg)



-  3/8"-16 x 1/4"
Socket Cup Point
-  Set Screws Included
- Material: Cast aluminum.

MATERIAL

Unistrut fittings, unless noted, are made from hot-rolled, pickled and oiled steel plates, strip or coil, and conform to ASTM specifications A575, A576, A635, or A36. The fitting steel also meets the physical requirements of ASTM A1011 S5 GR 33. The pickling of the steel produces a smooth surface free from scale.

Maple cable saddles, cable clamps and bus bar clamps are made from kiln-dry maple treated with paraffin to a depth of 1/16" (1.6mm). Special sizes of clamps can be fabricated upon request. Porcelain cable clamps are made by the dry process and white glazed. Cable saddles are fiberglass-reinforced polyester.

FINISHES

Components listed in this section are available in:

- Electro-galvanized (EG), conforming to ASTM B633 Type III SC1;
- Hot-dipped galvanized (HG), conforming to ASTM A123 or A153,
- Perma-Green III (GR),
- Plain (PL).

Note: Many Unistrut Metal Framing components, when used with appropriate closures, are UL® listed, and CSA approved. Imperial dimensions are illustrated in inches. Metric dimensions are shown in parenthesis or as noted. Unless noted, all metric dimensions are in millimeters and rounded to one decimal place.

| | |
|---|--|
| Project: _____ Architect / Engineer: _____ Date: _____ Phone: _____ Contractor: _____ Address: _____ _____ Notes 1: _____ _____ Notes 2: _____ _____ | Approval Stamp: |
|---|--|