

xx-HASP-xx Horizontal Adjustable Splice KIT

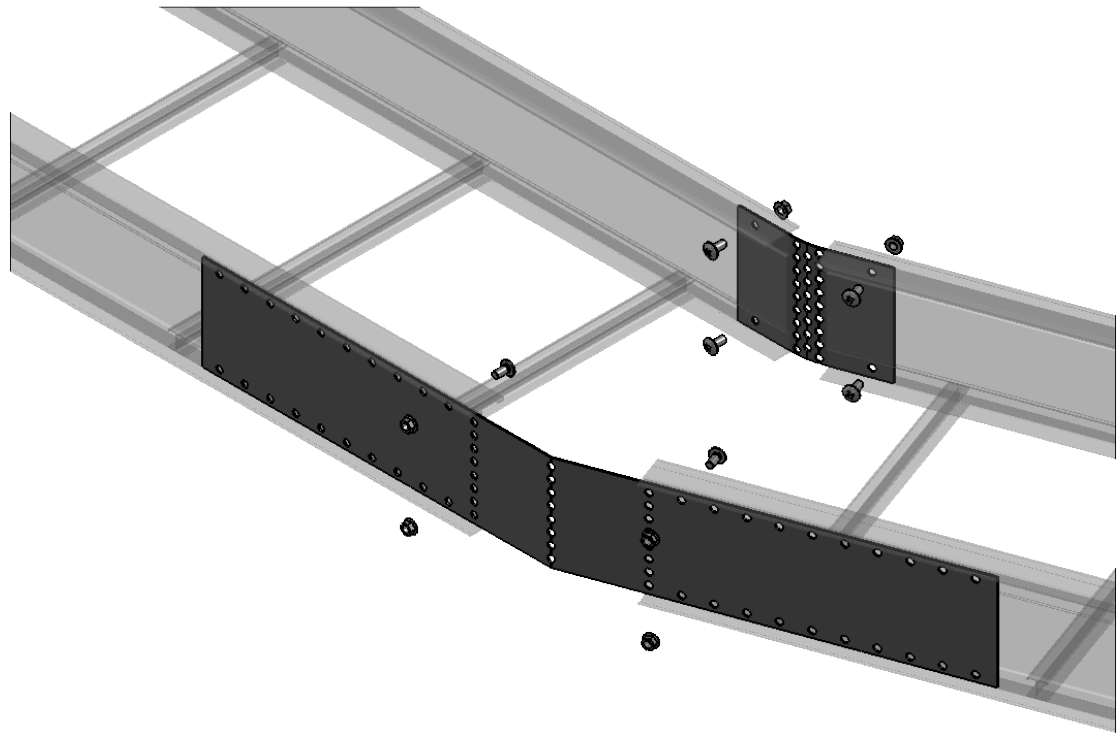

PART NAME	'H'	WEIGHT
4A-HASP-x	3.625	1.843
5A-HASP-x	4.625	2.289
6A-HASP-x	5.625	2.736
7A-HASP-x	6.625	3.182
4*-HASP-x	3.500	3.773
5*-HASP-x	4.500	4.814
6*-HASP-x	5.438	5.788
7*-HASP-x	6.250	6.632

NOTES:

- BEND PLATES TO APPROPRIATE ANGLE AS NEEDED
- FIELD DRILL OUTER PLATE IF REQUIRED
- TORQUE: 19 FT/LBS
- MEETS CABLE TRAY BONDING REQUIREMENTS (NO BONDING JUMPERS REQUIRED) WHEN TRAY IS NOT USED AS AN EGC
- KIT INCLUDES ONE INSIDE AND OUTSIDE PLATE AND ALL NECESSARY HARDWARE TO COMPLETE SPLICE CONNECTION

4A THRU 7A (A) REPRESENT ALUMINUM
 x REPRESENTS HARDWARE: GE or S6
 * REPRESENTS (STEEL) MATERIAL/FINISH:
 G -STEEL/HDGAF (after fab)
 T - STAINLESS/316

TRAY WIDTH	MAX ANGLE ALLOWED
6"	70°
9"	60°
12"	55°
18"	45°
24"	35°
30"	30°
36"	25°

Legrand
 8319 State Route 4
 Mascoutah, IL 62258 USA
 800-658-4641
 618-566-3230
 Fax 618-566-3250
www.legrand.us/cablofil