

# PHOTOCELL INPUT MODULE AND ANALOG PHOTOCELLS

## LMIO-301

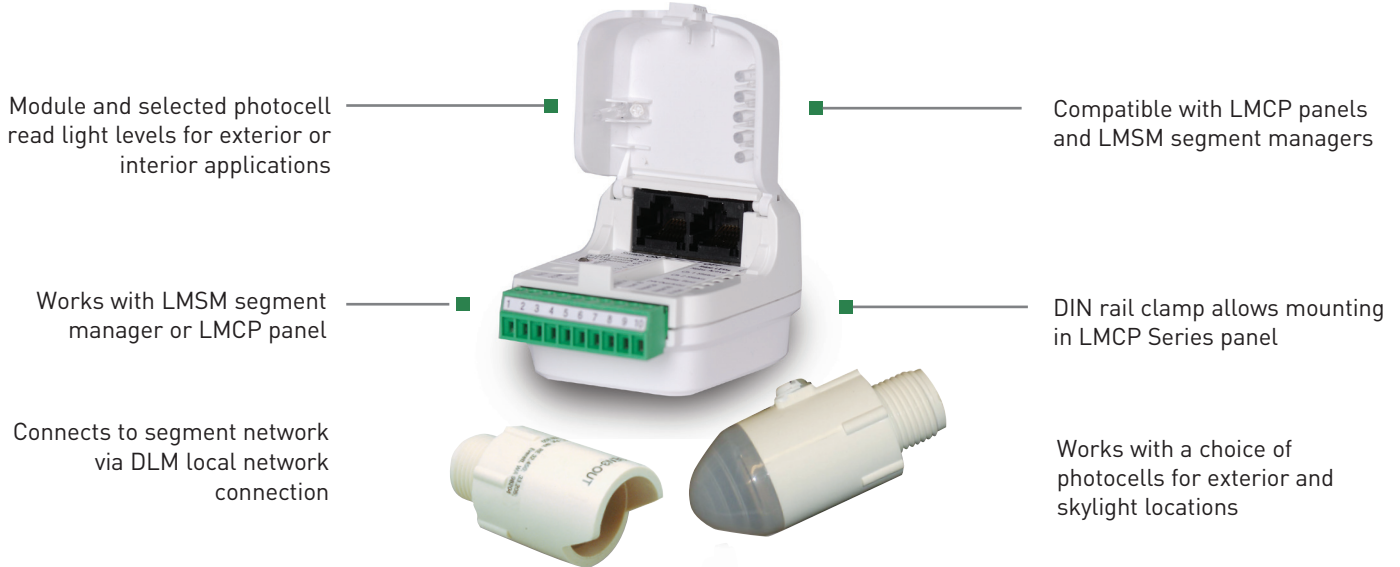

## Description

The LMIO-301 photocell input module is an accessory for a networked Digital Lighting Management (DLM) installation that allows an LMSM segment manager or LMCP panel to read ambient light levels for use in controlling exterior lighting or interior lighting installed in brightly daylight spaces such as atriums. The LMIO-301 works in conjunction with either the LMPO-200 exterior or LMPS-6000 skylight low voltage photocell heads.

## Operation

The LMIO-301 operates on Class 2 power supplied to a DLM local network by one or more room controllers. It transmits light levels over the segment network as read from one of the optional remote analog LMPO or LMPS photocell sensors. The LMIO-301 converts the 0-10 VDC signal from the photocell sensor to a digital signal that is shared across the network. The segment manager is configured to control the lighting based on user-defined setpoints and time delay settings.

## Features

- Requires LMSM segment manager or LMCP panel and LMPO-200 or LMPS-600 photocell
- Available accessory photocell heads for exterior and skylight/atrium applications
- Available range from 1 to 6000 footcandles
- Ambient light levels are available to connected building automation system

## Network Communication

The LMIO-301 can be installed on any DLM local network. The actual ambient light level as reported by the connected LMPO or LMPS photocell is communicated to the segment network via an LMBC-300 network bridge, and made available for use by an LMSM segment manager or BAS system. LMCP panels can read LMIO-301 footcandle levels directly.

## Applications

The LMIO-301 photocell input module is an ideal solution for any application where exterior lighting needs to be controlled based on actual ambient exterior light levels such as parking, site and landscape lighting. Applications with large expanses of skylight, clearstory or atrium glazing can also benefit from controlling lighting based on ambient light entering the building through the glazing. When controlling outdoor lighting, the photocell head is mounted on the roof of the building facing north. The LMPO-200 photocell head is waterproof and has a built in hood to shield the lens from direct sunlight. The LMPS-6000 photocell head is designed for direct exposure to extremely high light levels as would be present adjacent to the glass in an atrium, skylight or clearstory.

- Two RJ45 ports with hinged dust cover
- UL 2043 plenum rated
- Supplied with DIN rail adaptor for Class 2 installation
- This product meets the materials restrictions of RoHS
- BAA/TAA-compliant models available

PROJECT	LOCATION/ TYPE

## Specifications

### LMIO-301:

- Operating voltage: 24VDC from DLM local network
- Maximum current consumption: 17mA
- Maximum output power: 5mA
- Class 2 connection terminals: 24VDC photocell supply, common, 0-5VDC input, 0-10VDC input
- DLM local network connection: 2 RJ45 ports
- Adjustable sample rate: 1-60 seconds, 1 second resolution, 30 second default setting
- Percentage delta for sample: 1-100%, 1% resolution, 1% default setting
- Operating conditions: for indoor use only; 32-104°F (0-40°C)
- Fits inside 4" x 4" j-box, 1-gang back box or 3" octagonal box; optional DIN rail mounting
- UL and cUL listed

- FCC part 15 compliant

- Five year warranty

### Analog Photocells:

- Input voltage: 24 VDC, from LMIO-301
- Light level resolution:
  - LMPO-200: 0-200fc (0-2153 lux), 1fc/step
  - LMPS-6000: 0-6000fc (0-64583 lux), 24fc/step
- Mounting, ½" NPT x .69" threaded stem
- Housing, UV stabilized plastic
- Slew rate, one minute full scale response time
- Operating temperature: -40-140°F (-40-60°C)
- UL and cUL listed
- Five year warranty

## Dimensions, Mounting, Wiring & Placement

### LMIO-301

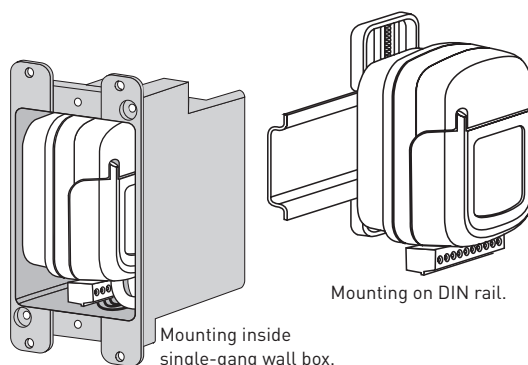
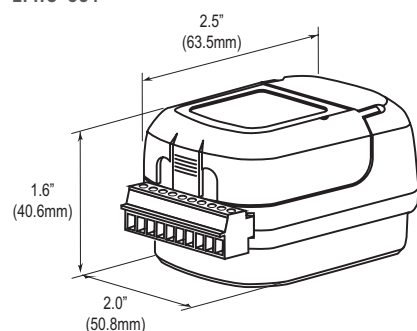

### LMIO-301 Low Voltage Terminals

Position (L-R)	Description
4	COMMON
5	+24VDC
9	0-5V input
10	0-10V input (standard)

### LMPO-200 Outdoor Application

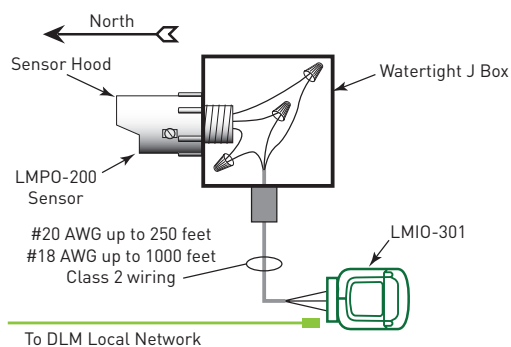

### LMPS-6000 Skylight Application

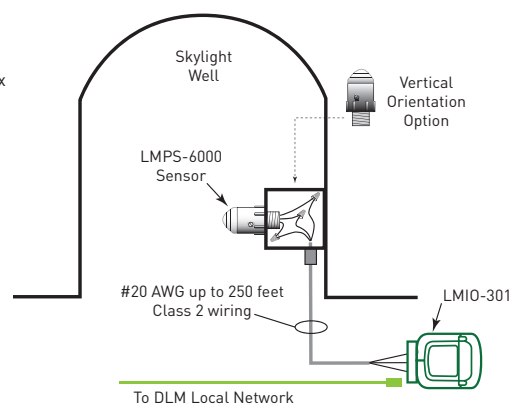

### LMPO-200

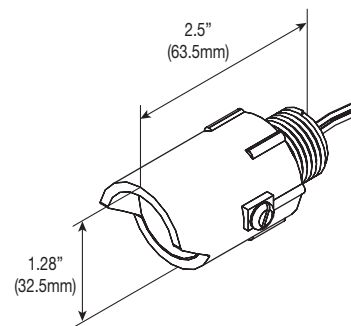

### LMPS-6000

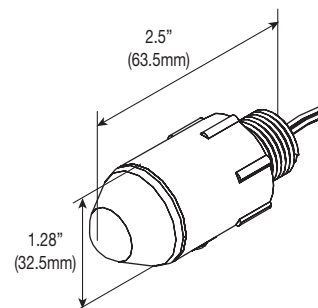

## Ordering Information

Catalog #	Description
<input type="checkbox"/> LMIO-301	Photocell Input Module
<input type="checkbox"/> LMIO-301-U	Photocell Input Module, BAA/TAA compliant*
<input type="checkbox"/> LMPO-200	Analog Exterior Photocell Accessory, 0-200 footcandles
<input type="checkbox"/> LMPS-6000	Analog Interior Photocell Accessory, 0-6000 footcandles

Note: Order LIMO-301 and either LMPO-200 or LMPS-6000.

\*Product is compliant with Buy American Act and Trade Agreement Act