

## TDR15-W



UPC Code: 07847738182

Country Of Origin: Mexico

\*Eligible for ARRA funded projects > \$7,443,000

NEMA:  
5-15R



## TDR15-W

### Brand Features

Plug Into Safety with Leviton's Line of Tamper-Resistant (TR) Receptacles. Leviton makes it easy for you to comply with the current NEC mandate for TR Receptacles in all new residential housing. This requirement resulted from a Consumer Product Safety Commission study, that reported alleged injuries in the home caused each year by children attempting to insert foreign objects into receptacles. TR receptacles have been mandated in pediatric care areas for over 20 years and have likely been successful in preventing electrical injuries. As a long-time manufacturer of tamper-resistant devices, we are pleased to be at the forefront of this safety measure with an expanded product line that encompasses a wide range of TR devices in Residential, Commercial, Industrial and Hospital Grades.

### Item Description

15 Amp, 125 Volt, NEMA 5-15R, 2P, 3W, Tamper-Resistant, Decora Plus, Duplex Receptacle, Straight Blade, Commercial Grade, Self Grounding, , Back & Side Wired, Steel Strap, - WHITE

### Technical Information

AC Horsepower Ratings

**At Rated Voltage:** 1/2 HP

Electrical Specifications

**Dielectric Voltage:** Withstands 2000V per UL498

**Grounding:** Self-Grounding

**Temperature Rise:** Max 30C after 250 cycles OL at 200 percent rated current

**Voltage:** 125 Volt

**Amperage:** 15 Amp

**Current Limiting:** Full Rated Current

**Wire:** 3

**Pole:** 2

Environmental Specifications

**Operating Temperature:** -40C to 60C

**Flammability:** Rated V-2 per UL94

Material Specifications

**Strap Material:** Zinc-Plated Steel

**Body Material:** Nylon

**Face Material:** Nylon

**Ground Clips:** Brass-Plated

**Terminal Screws:** Brass 10-32

**Color:** White

**Line Contacts:** Brass Triple-Wipe

**Clamp Nuts:** Zinc-Plated Steel

**Grounding Screw:** Brass 8-32

Mechanical Specifications

**Product ID:** Ratings are permanently marked on device

**Terminal ID:** Brass-Hot, Green-Ground, Silver-Neutral

**Termination:** Back & Side

**Terminal Accom.:** 14-10 AWG

Product Features

**Color:** White

**NEMA:** 5-15R

Standards and Certifications

**UL 498:** File E13399

**Warranty:** 10 Year Limited

**CSA C22.2 No. 42:** File 152105

**ANSI:** C-73

**NOM:** 057

**NEMA:** WD-1 & WD-6

## Dimensional Diagram

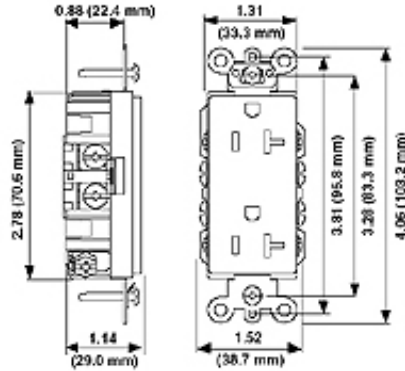

## Wiring Diagram

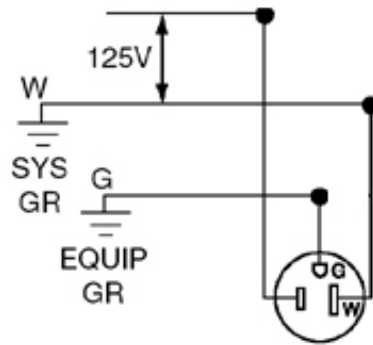

5-15R

## SPECIFICATION SUBMITTAL

JOB NAME: <input type="text"/>	CATALOG NUMBERS: <input type="text"/>	<input type="text"/>
JOB NUMBER: <input type="text"/>	<input type="text"/>	<input type="text"/>

### Leviton Manufacturing Co., Inc.

201 North Service Road, Melville, NY 11747

Teléfono: +1-800-323-8920 · FAX: +1-800-832-9538 · Tech Line (8:30AM-7:30PM E.S.T. Monday-Friday): +1-800-824-3005

### Leviton Manufacturing of Canada, Ltd.

165 Hymus Boulevard, Pointe Claire, Quebec H9R 1E9 · Telephone: +1-800-469-7890 ·

FAX: +1-800-824-3005 · [www.leviton.com/canada](http://www.leviton.com/canada)

### Leviton S. de R.L. de C.V.

Lago Tana 43, Mexico DF, Mexico CP 11290 · Tel.: (+52)55-5082-1040 · FAX: (+52)5386-

1797 · [www.leviton.com.mx](http://www.leviton.com.mx)

Visit our Website at: [www.leviton.com](http://www.leviton.com)

© 2012 Leviton Manufacturing Co., Inc. Todos los derechos reservados. Subject to change without notice.

### Leviton has a global presence.

If you would like to know where your local Leviton office is located please go to:

[www.leviton.com/international/contacts/](http://www.leviton.com/international/contacts/)



*\*Leviton is the smart choice, providing the most comprehensive range of solutions to meet the needs of today's residential, commercial and industrial buildings. Leveraging more than a century of experience, Leviton helps customers create sustainable, intelligent environments through its electrical wiring devices, network and data center connectivity solutions, and lighting energy management systems. From switches and receptacles, to daylight harvesting controls, networking systems, and equipment for charging electric vehicles, Leviton solutions help customers achieve savings in energy, time and cost, all while enhancing safety.*