

Floor Boxes
 Flush Rectangular Cast Iron
 Concrete Floor Boxes

HUBBELL



Features

- Corrosion resistant for on-grade applications
- Gray Powder Coat Paint
- Adjustable Before and After Concrete Pour



Ordering Information

Description	Collar Material	UPC Number	Catalog Number
Three Gang Floor Box	Brass	783585103006	B4333

Listings

UL Listed File Number E92074
 CSA File Number LR18416

Specifications

Style	Cast Iron
Capacity Per Gang	34.8 cu. in. (570.3 cm ³)
Threaded NPT Hubs	(8) 3/4"

Performance

Installation Information	
Min. Depth of Pour	3.75" (95.3)
Post Pour Adjustment	0.63"

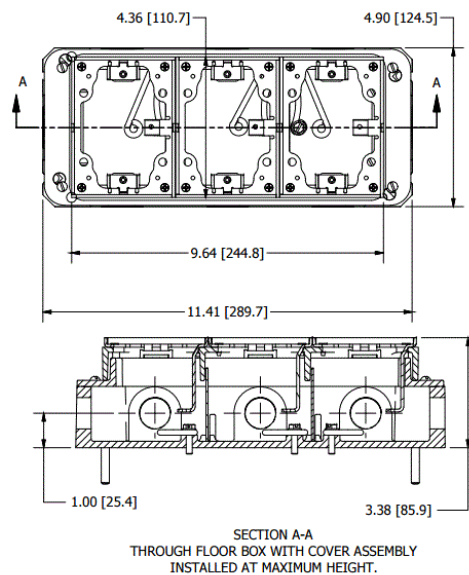

Complementary Products

Replacement Collar	C4300
Replacement Brass Cover Flange	S5017A

Online Resources

Customer Use Drawing
 eCatalog
 Installation Instructions

Dimensions in Inches (mm)

Hubbell Wiring Device-Kellems • Hubbell Incorporated (Delaware) • 40 Waterview Drive • Shelton, CT 06484

Phone (800) 288-6000 • Fax (800) 255-1031 • Specifications subject to change without notice.

