

REG

Regulator™ Illuminated Circuit Breaker/Power Limit Switch

Specifications/Features

Features

Limits the amount of electrical load that can be placed on the circuit.
 Quick connect blade terminals for easy connection to included pigtailed.
 Easy switch like breaker re-set actuator with ON/OFF markings. May be used as a standard ON/OFF switch.
 Illuminated Rocker Switch is easily seen from floor level to confirm that power is being supplied to track circuit.
 The breaker snaps into the Regulator track connector without the use of tools.
 For use with the following current limiting devices:

- LA-23, LA-33, LA-223 and LA-233 Series
- LBC22
- NTEK11CB
- NTEK12CB
- LIRCLD

Electrical

120V/60Hz capacity.
 All fixtures are polarized and continuously grounded throughout.
 Electrical conductors are concealed in an insulating liner.
 Intended for wiring to branch circuit building Noryl® wire with ground.
 All wiring should meet National and local electrical codes.
 Use 12 gauge 90° C minimum supply wire.

Listing

cCSAus Certified.
 Approved by the California Energy Commission.

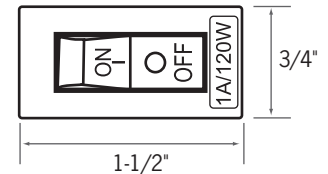
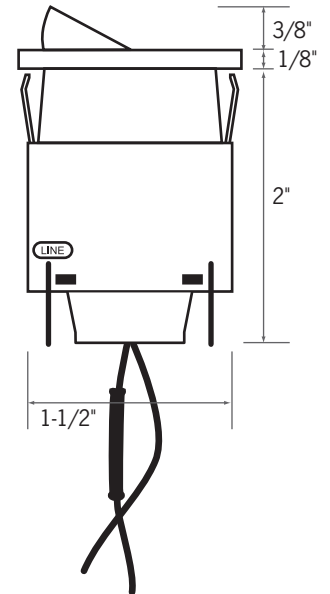

Ordering Information

Example Order: -

Circuit Breaker

Finish

- | | |
|-----------------------------|---------------------------|
| REG0.05A - 60W, 0.5A | REG7 - 720W, 6A |
| REG1 - 120W, 1A | REG8 - 840W, 7A |
| REG2 - 210W, 1.75A | REG9 - 900W, 7.5A |
| REG21 - 240W, 2A | REG91 - 960W, 8A |
| REG3 - 300W, 2.5A | REG10 - 1200W, 10A |
| REG4 - 360W, 3A | REG12 - 1440W, 12A |
| REG5 - 480W, 4A | REG14 - 1680W, 14A |
| REG6 - 600W, 5A | |

- B** - Black
- P** - White
- S** - Silver

REG

Regulator™ Illuminated Circuit Breaker/Power Limit Switch

InRush Current

Inrush Current is input current of short duration which occurs at start-up that is greater than the normal operating current of an LED lamp or luminaire. For example, the number of lamps or luminaires able to be installed on a circuit seems like a simple question to answer, but when using an LED load, a 300W dimmer with a 50W luminaire does not necessarily mean 6 luminaires can be used on this dimmer. While the luminaire may draw 50W continuously, it may have a start-up inrush current which draws a much higher load. These higher loads are why the LED luminaire load rating is usually less than the maximum rating of the dimmer. When designing a circuit of LED luminaires, you should leave at least 25% of the circuit capacity open to accommodate this condition, but specific system properties may require more capacity.

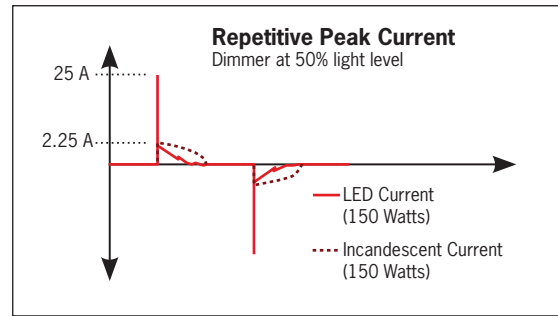
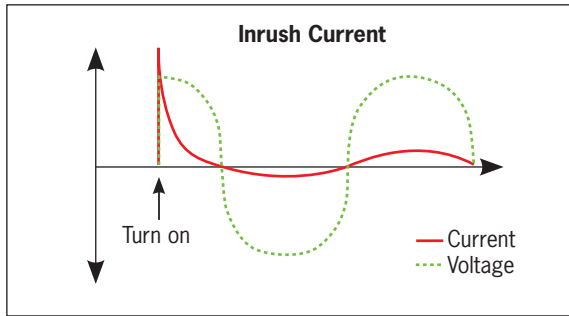

Source: Lutron