

# E228

Miniature Low Voltage  
Halogen Downlight

## PROJECT INFORMATION:

Project Name: \_\_\_\_\_

Fixture Type: \_\_\_\_\_

Date: \_\_\_\_\_

## DIMENSIONS

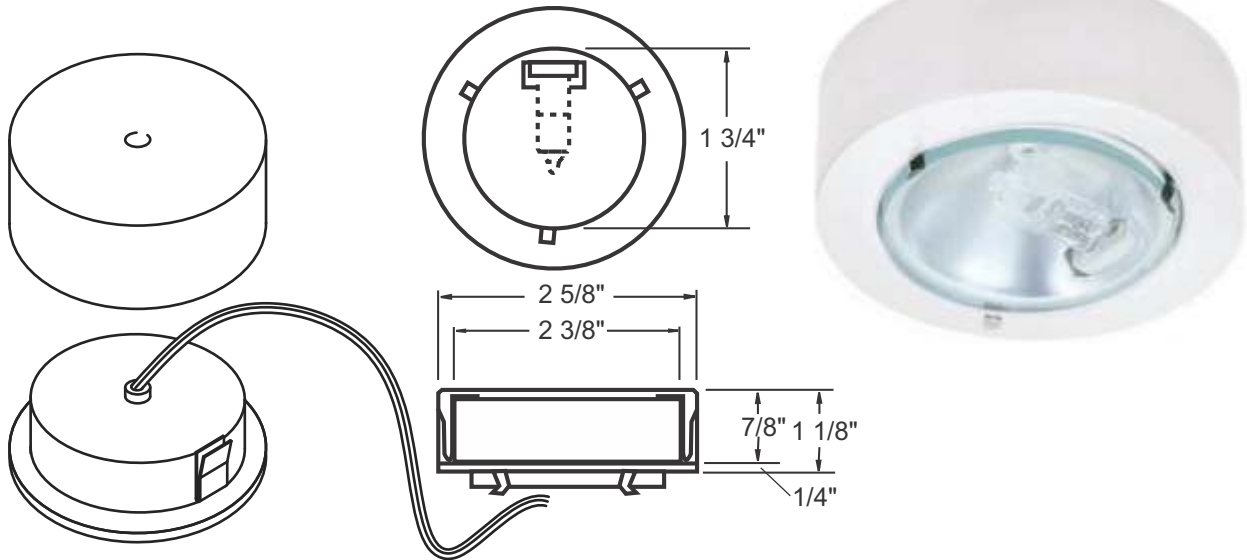

## PRODUCT SPECIFICATIONS

- 1 3/4" reflector with protective glass lens.
  - 1/2" square side knockout.
  - 1/2" knockout on the bottom of housing.
  - 18" wires with terminal connectors.
  - For surface or recessed mounting.
  - 12V power supply (not included, sold separately)
- Lamp:** 20W Max 12V JC bi-pin lamp (included)
- Lamp Holder:** JC bi-pin socket
- Labels:** ETL listed for remote transformer (not included)

## INSTALLATION

Housing is secured onto ceiling first by 2 screws.  
Front reflector trim is inserted into housing securely  
by two pressure clips.

## CATALOG NUMBER

**Example:** E228B (Black)  
E228C (Aluminum Die-cast)  
E228G (Gold)  
E228N (Brushed Nickel)  
E228W (White)

E228BS (Black, Sanded Glass Lens)  
E228GS (Gold, Sanded Glass Lens)  
E228NS (Brushed Nickel, Sanded Glass Lens)  
E228WS (White, Sanded Glass Lens)