

DESCRIPTION:
SNAPNRACK, CORRUGATED STRADDLE BLOCK

PART NUMBER(S):
242-02046

DRAWN BY:
 D.Ryan

REVISION:
A

SnapNrack™
 Solar Mounting Solutions

595 MARKET STREET, 29TH FLOOR • SAN FRANCISCO, CA 94105 USA
 PHONE (415) 580-6900 • FAX (415) 580-6902

THE INFORMATION IN THIS DRAWING IS CONFIDENTIAL AND PROPRIETARY. ANY REPRODUCTION, DISCLOSURE, OR USE THEREOF IS PROHIBITED WITHOUT THE WRITTEN CONSENT OF SUNRUN SOUTH LLC.

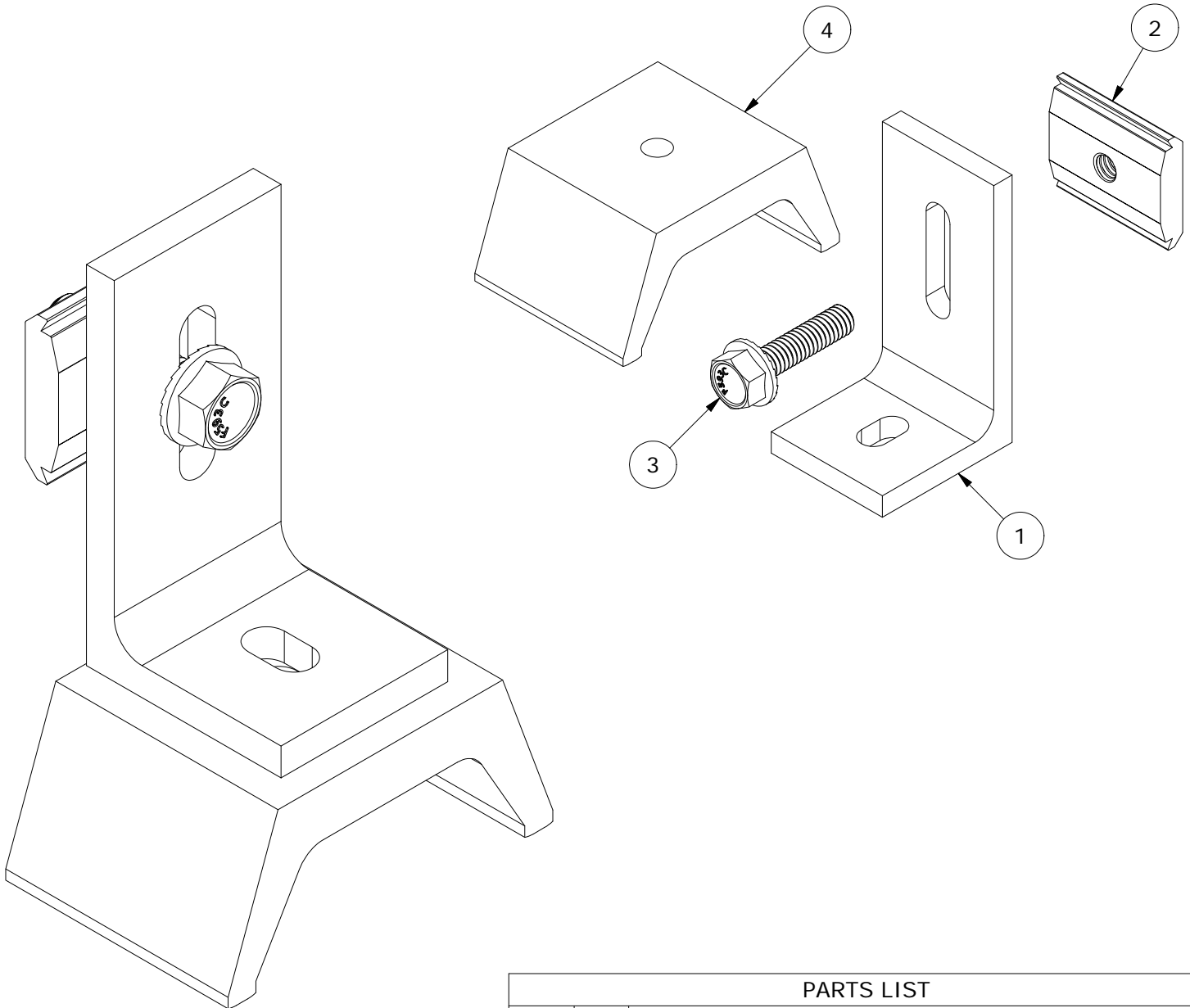

PARTS LIST		
ITEM	QTY	DESCRIPTION
1	1	SNAPNRACK L FOOT, ALL PURPOSE 90DEG, CLEAR
2	1	SNAPNRACK, ORIGINAL CHANNEL NUT
3	1	BOLT, FLANGED HEX, 5/16IN-18 X 1-1/4IN, SS
4	1	SNAPNRACK, CORRUGATED STRADDLE BLOCK, MILL

MATERIALS:	6000 SERIES ALUMINUM, STAINLESS STEEL	OPTIONS:
DESIGN LOAD (LBS):	700 UP, 330 DOWN, 500 SIDE	
ULTIMATE LOAD (LBS):	1148 UP, 472 DOWN, 971 SIDE	
TORQUE SPECIFICATION:	10+ LB-FT	
CERTIFICATION:	UL 2703, FILE E359313	
WEIGHT (LBS):	0.55	

DESCRIPTION:

SNAPNRACK, CORRUGATED STRADDLE BLOCK

DRAWN BY:

D.Ryan

SnapNrack™
Solar Mounting Solutions

PART NUMBER(S):

242-02046

REVISION:

A

595 MARKET STREET, 29TH FLOOR • SAN FRANCISCO, CA 94105 USA
PHONE (415) 580-6900 • FAX (415) 580-6902

THE INFORMATION IN THIS DRAWING IS CONFIDENTIAL AND PROPRIETARY. ANY REPRODUCTION, DISCLOSURE, OR USE THEREOF IS PROHIBITED WITHOUT THE WRITTEN CONSENT OF SUNRUN SOUTH LLC.

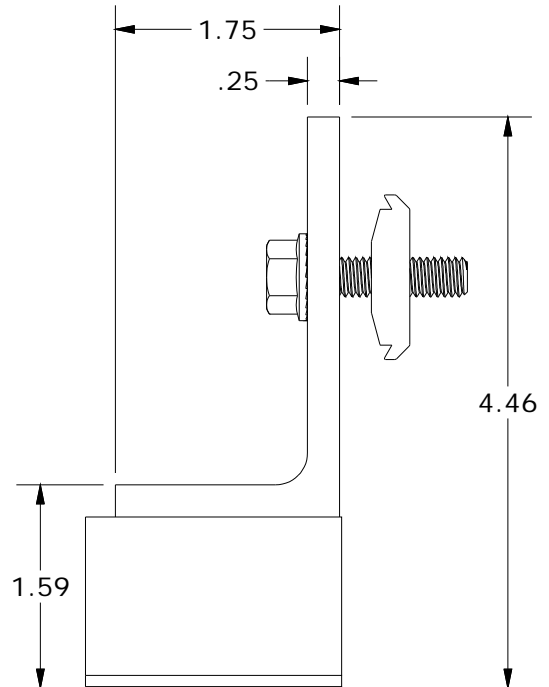
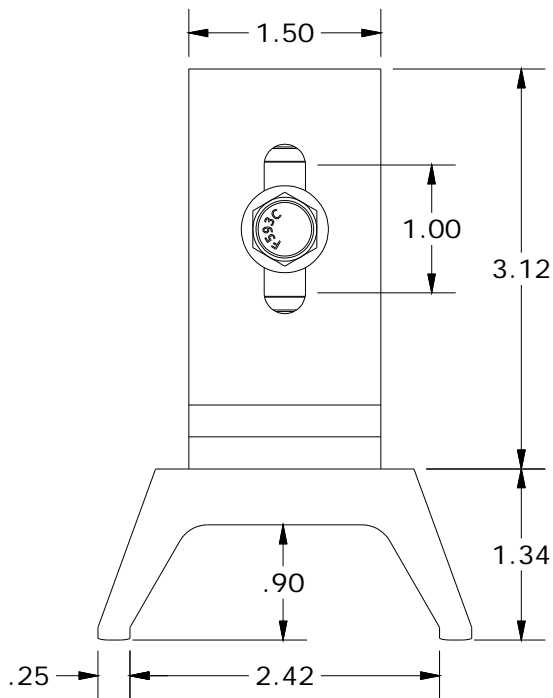
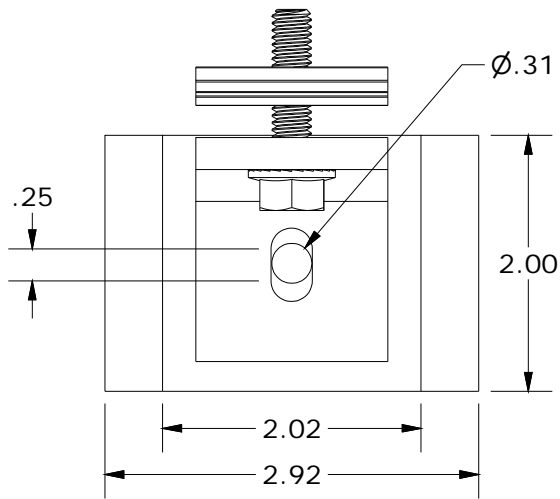

ALL DIMENSIONS IN INCHES