

DESCRIPTION

The WSN Series is a specification wraparound luminaire featuring energy efficient performance. The luminaire's characteristic clean, low profile design is both appealing and practically functional. The WSN Series utilizes a clear, low brightness, extruded acrylic refractor with injection molded end caps for high performance and good looks.

The efficient and stylish WSN Series is the perfect wraparound for commercial spaces, schools, dormitories, offices and retail areas.

Catalog #		Type
Project		
Comments		Date
Prepared by		

SPECIFICATION FEATURES

Construction

Housing die formed code gauge prime cold rolled steel. Six full length ribs for strength. Ballast cover easily removed without tools. Steel end plates with 7/8" KO and light-seal embossment. Couplers for continuous row mounting.

Electrical*

Ballasts are CBM/ETL Class "P" and are positively secured by mounting bolts. Pressure lock lampholders. UL/CUL listed. Suitable for damp locations.

Finish

Multistage, iron phosphate pretreatment ensures maximum bonding and rust inhibitor. Lighting grade, baked white enamel finish.

Frame/Shielding

100% clear full thickness virgin acrylic prismatic refractor/lens. Permanent luminous injection molded end caps. Sides have inside linear prisms and bottom has pyramidal prisms for low brightness control. Lens can be hinged from either side in a lift and shift manner.



**WSN
232**

**4' OR 8' SURFACE
2 LAMPS**

Specification Wrap

MOUNTING DATA

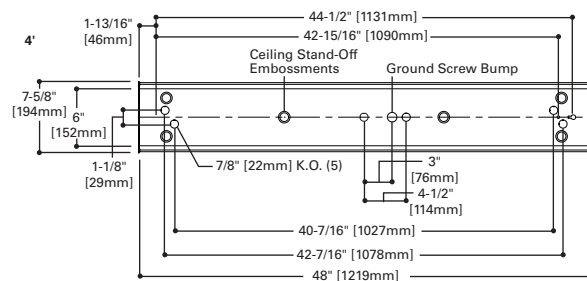
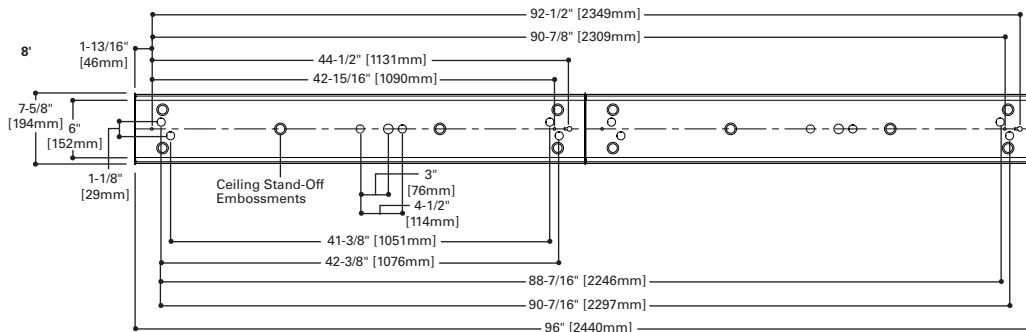

LIFT & SHIFT REFRACTOR

Easily Removed. Hinges Either Side
(Not Recommended For Sloped Ceiling Applications.)

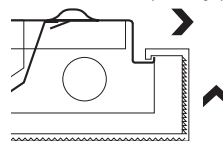

LAMPS CONTAIN MERCURY. DISPOSE ACCORDING TO LOCAL, STATE OR FEDERAL LAWS

LINEAR DISCONNECT

Safe and convenient means of disconnecting power.

ORDERING INFORMATION

SAMPLE NUMBER: WSN-232A-UNV-EB81-U

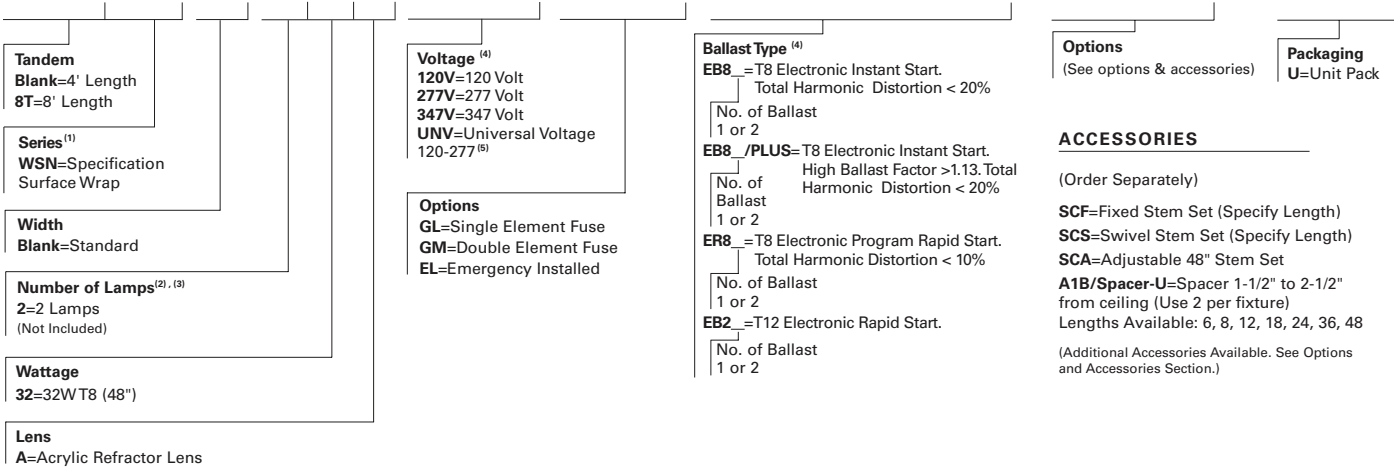

NOTES: ⁽¹⁾Steel endplates with 7/8" KO standard for continuous row mounting. ⁽²⁾Stem mounting not available on 3-lamp fixtures. ⁽³⁾2 point suspension recommended for 2 and 4-lamp fixtures. ⁽⁴⁾Products also available in non-US voltages and frequencies for international markets. ⁽⁵⁾Not available when specifying emergencies, voltage must be specific.

For complete product data, reference the Fluorescent Specification binder. Specifications & dimensions subject to change without notice. Consult your Eaton Representative for availability and ordering information.

SHIPPING DATA

Catalog No.	Wt.
WSN-232A	17 lbs.
8TWSN-232A	33 lbs.