

TYPE FDI FLOOR DROP-IN HEATERS

- Quiet - for living rooms, dining rooms, even bedrooms.
- A "versatile, universal size", draft barrier heater for large window areas, sliding glass doors, entryways, hallways, open stair wells...
- Produces a flow pattern of warm air five feet wide (four feet above floor). Single compact size (14" length x 7-1/4" width).
- Both the FDI1500 and FDI1504 are adaptable from 1500W to 750W. Additionally, the FDI1504 may be operated at 208 volts for an output of 1125W or 563W.
- Quick, simple installation. Mounts between floor joists in either direction (parallel or perpendicular to joists). Rough-in separate housing... then simply insert "plug-in" type heater element and fan assembly.
- Heavy-duty grille can take almost any type of abuse!
- Thermostat accessory kit easily installed in heater (screwdriver adjusted thru grille).k. When heater is installed for overall room heating, use a wall thermostat.
- Automatic overheat thermal protector and thermal fuse standard.
- Heavy-gauge steel housing.
- Sandalwood baked enamel grille finish.
- 80 CFM.

DIMENSIONS

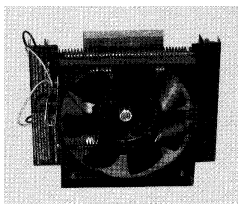
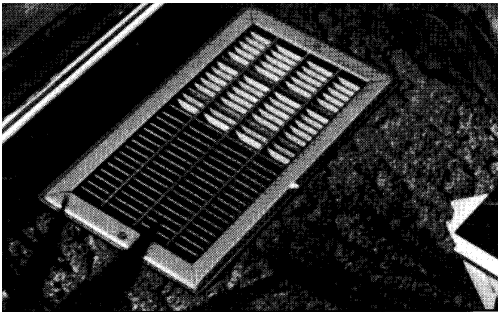
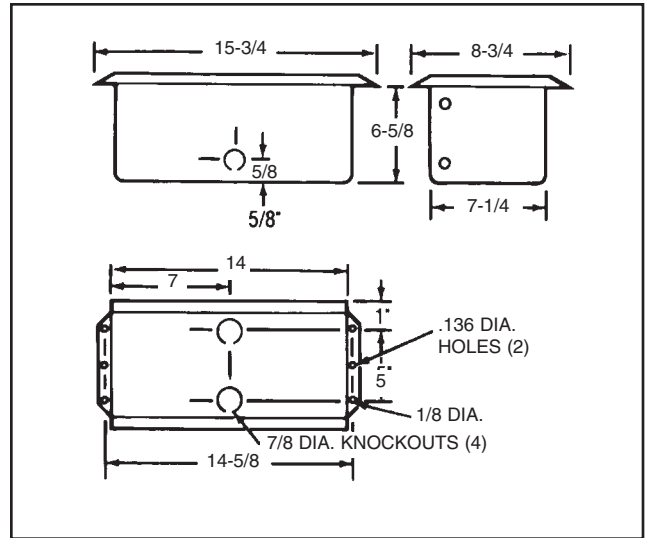

SELECTION CHART

*Volts	Watts	BTU/Hr.	Amps	Cat. No.
120	1500	5120	12.5	FDI1500
	750	2560	6.3	
208	1125	3840	5.4	FDI1504
	562	1920	2.7	
240	1500	5120	6.3	
	750	2560	3.1	

ACCESSORIES

FDI-TSP	Integral Thermostat Kit (55° -115° F)
---------	---------------------------------------

ARCHITECT'S AND ENGINEER'S SPECIFICATIONS*

Furnish and install, where indicated on plans, FDI electric fan forced air heater suitable for installing in the floor as manufactured by QMark, a Marley Engineered Products Brand, Bennettsville, SC. Heaters shall be UL Listed and c-UL Listed.

ENCLOSURE: The heater shall be fabricated of 20-gauge cold rolled steel, completely welded, then painted by a baked enamel finish. The louvered grille and grille frame shall be finished in sandalwood color by a baked enamel painting process.

HEATING ELEMENT: The heating element shall be guaranteed for five years and shall be non-glowing design consisting of a special 80/20 NiChrome resistance wire enclosed in a steel sheath to which steel fins are brazed.

* QMark reserves the right to change specifications without prior notice.

MOTOR AND CONTROLS:

The fan motor shall be impedance protected and permanently lubricated. An optional single pole thermostat accessory shall be specified where the unit will not utilize wall thermostat. The over temperature protector shall be bi-metallic, snap-action type designed to shut off heater in the even of overheating. A thermal fuse shall provide secondary thermal cut-out for added safety.

