

3763C



UPC Code: 07847780439

Country Of Origin: Mexico

**Eligible for ARRA funded projects > \$7,443,000*

NEMA:
Non-NEMA



3763C

Brand Features

Leviton's Black &White 50 Amp, Non-NEMA line of industrial grade locking blade devices feature rugged construction that resists impact, sunlight, chemicals and rough use. All contacts and blades are solid one-piece construction for superior conductivity. Corrosion resistant versions feature nickel plated contacts and blades, plus stainless steel shrouds and screws. The ergonomic, fluted-body design with radial gripping edge is ideal for gripping and pulling. The unique cord clamp accepts a wide range of cord sizes, providing a secure grip without damaging the cord. And, they are backed by a limited lifetime warranty.

Item Description

50 Amp, 250 Volt DC/600 Volt AC, Non-NEMA, 2P, 3W, Locking Plug, Industrial Grade, Grounding - BLACK-WHITE

Technical Information

Electrical Specifications

Dielectric Voltage Withstand: 2000V minimum per UL 498

Grounding: Grounding

Temperature Rise: Max 30°C temp rise at full-rated current after 150 cycles of OL at 150% rated DC current

Maximum Working Voltage: 250V DC/600V AC as rated

Voltage: 250 Volt DC/600 Volt AC

Current Interrupting: Certified for current interrupting at full rated current

Amperage: 50 Amp

Wire: 3

Pole: 2

Environmental Specifications

Operating Temperature: -40deg.C to 75deg.C (-40deg.F to 167deg.F)

Flammability: UL94V-2

Material Specifications

Terminal Set Screw: SS 302/304

Ground Shunt: Bronze

Wiring Chamber: Nylon

Housing Material: Nylon

Cable Clamp Screw: Philips Head, SS 304

Color: Black-White

Ground Post: Brass

Plug Blade: 0.1000inch thick Brass

Face Module: Nylon

Plug Blade Shroud: SS 302/304

Terminal Block: 0.062inch thick Copper

Standard Cable Clamp: Nylon

Dust Shield: Santoprene TPE

Assembly Screws: Brass

Mechanical Specifications

Product ID: Ratings and Catalogue No. molded into face and stamped into shroud

Terminal ID: X, W, Y, Z and Green for ground

Terminal Accom.: #10 min to #4max AWG Solid or Stranded Wire

Cord Range: .680 - 1.125

Product Features

Color: Black-White

NEMA: Non-NEMA

Standards and Certifications

UL 498: File E13399

Warranty: Lifetime Limited

CSA C22.2 No. 42: File 152105

NOM: 057

RoHS: Compliant

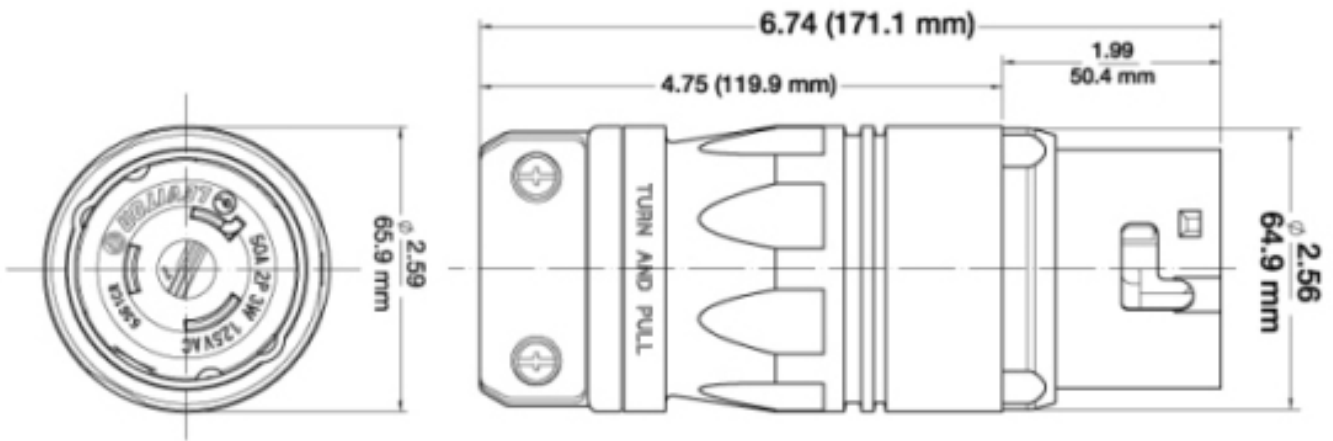

SPECIFICATION SUBMITTAL

JOB NAME:	CATALOG NUMBERS:	
<input type="text"/>	<input type="text"/>	<input type="text"/>
JOB NUMBER:	<input type="text"/>	<input type="text"/>

Leviton Manufacturing Co., Inc.

201 North Service Road, Melville, NY 11747

Teléfono: +1-800-323-8920 · FAX: +1-800-832-9538 · Tech Line (8:30AM-7:30PM E.S.T. Monday-Friday): +1-800-824-3005

Leviton Manufacturing of Canada, Ltd.

165 Hymus Boulevard, Pointe Claire, Quebec H9R 1E9 · Telephone: +1-800-469-7890 ·

FAX: +1-800-824-3005 · www.leviton.com/canada

Leviton S. de R.L. de C.V.

Lago Tana 43, Mexico DF, Mexico CP 11290 · Tel.: (+52)55-5082-1040 · FAX: (+52)5386-

1797 · www.leviton.com.mx



Visit our Website at: www.leviton.com

© 2012 Leviton Manufacturing Co., Inc. Todos los derechos reservados. Subject to change without notice.

Leviton has a global presence.

If you would like to know where your local Leviton office is located please go to:

www.leviton.com/international/contacts/

**Leviton is the smart choice, providing the most comprehensive range of solutions to meet the needs of today's residential, commercial and industrial buildings. Leveraging more than a century of experience, Leviton helps customers create sustainable, intelligent environments through its electrical wiring devices, network and data center connectivity solutions, and lighting energy management systems. From switches and receptacles, to daylight harvesting controls, networking systems, and equipment for charging electric vehicles, Leviton solutions help customers achieve savings in energy, time and cost, all while enhancing safety.*