

Rigid Watertight Hubs

Hot Dip Galvanized - Malleable Iron

Features

- Flame-retardant insulated throat
- Male hub thread-NPT
- Female thread for Rigid conduit and IMC-NPT
- Recessed o-ring assures watertight and dust tight connections
- Type NHUB with insulated throat and bonding locknut is suitable for service entrance applications
- RoHS compliant

Applications

- Indoor or outdoor use
- Use to connect Rigid or IMC conduit to a load center or other metal enclosure where a watertight joint is required at knockouts or slip-fit holes

Standard Material

- Malleable iron

Standard Finish

- Hot dip galvanized



Conforms to finish thickness ASTM
A123/123M
UL2239
Fed. Spec. A-A-50553
NEMA FB 1

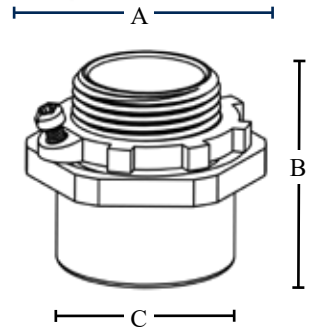

Catalog Number	UPC	Size	Unit Carton	Ship Case	Weight/Case	Inches		
						A		C
201MHDG	00488	1/2"	25	250	58	1.54	1.36	1.09
202MHDG	00490	3/4"	10	100	34	1.77	1.50	1.30
203MHDG	00491	1"	10	100	52	2.15	1.77	1.59
204MHDG	00492	1-1/4"	2	20	17	2.50	1.93	1.94
205MHDG	00494	1-1/2"	2	20	21	3.01	1.97	2.20
206MHDG	00495	2"	---	10	15	3.35	2.05	2.68
207MHDG	00496	2-1/2"	---	5	14	3.92	2.76	3.25
208MHDG	00497	3"	---	5	19	4.74	2.99	3.92
209MHDG	00498	3-1/2"	---	5	24	5.39	3.09	4.46
210MHDG	00499	4"	---	1	8	5.91	3.31	4.82
210AMHDG	01862	5"	---	1	8	3.46	7.36	6.10
210BMHDG	01863	6"	---	1	11	3.62	8.39	7.25