

KT-EMRG-LED-12-1200-K1

CONSTANT WATTAGE LED EMERGENCY BACK-UP



DESCRIPTION

LED Emergency Back-Up Driver Kit | 12W Output | 120-277V Input

| |
|--|
| DRIVER TYPE: Constant Wattage LED Emergency |
| MAX. OUTPUT POWER: 12W |
| INPUT VOLTAGE: 120-277Vac \pm 10% |
| OUTPUT VOLTAGE: 12~41 Vdc |
| OUTPUT CURRENT: 1000mA-200mA |
| WARRANTY: 5 Years |



PRODUCT FEATURES

- Drives Dedicated LED Load (Included) at 12W for a Minimum of 90 Minutes
- Meets FCC Part 15 (Class B) Consumer Limits
- Short Circuit Overload and Open Load Protection
- Type 1 Outdoor, Suitable for Dry and Damp Locations
- Evaluated to UL 924 Standards
- Operating Temperature: 32°F/0°C to 122°F/50°C
- Input Frequency: 50/60 Hz
- Test Switch/Charging Indicator Light
- Battery Pack with Quick Connect; NiCd
- Battery Capacity: 3000mAh

SPECIFICATIONS

ELECTRICAL SPECIFICATIONS

| Family | INPUT CHARACTERISTICS | | | OUTPUT CHARACTERISTICS | | |
|--------|-----------------------|--------------|--------------|------------------------|----------------------|----------------|
| | Input Voltage | Power Factor | Max. Current | Max. Output Power | Rated Output Current | Output Voltage |
| 12W | 120-277Vac | \geq 0.5 | 0.07A @ 120V | 12W | 1000mA-200mA | 12~41Vdc |

Emergency pack designed to deliver 12W to a constant current LED load. Approximate output is 1200 lumens assuming a nominal minimum efficacy of 100lm/W.

MECHANICAL SPECIFICATIONS

CASE DIMENSIONS

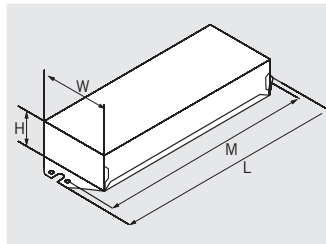

| | |
|----------------------|-------|
| LENGTH | 6.46" |
| WIDTH | 1.37" |
| HEIGHT | 1.00" |
| MOUNTING | 6.00" |
| CASE STYLE | L7 |
| CASE MATERIAL | METAL |

STANDARD LEAD LENGTHS*

| | |
|--------------------|-----|
| WHITE | 12" |
| BLACK | 12" |
| WHITE/BLACK | 12" |
| RED | 24" |
| BLUE | 24" |
| BROWN | 24" |

*Consult Keystone for special lead length requirements.
 Lead wires are 18 AWG 105°C/600V.

BATTERY SIZE

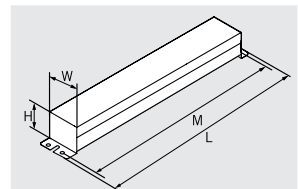

| | |
|-----------------|-------|
| LENGTH | 9.45" |
| WIDTH | 2.23" |
| HEIGHT | 1.02" |
| MOUNTING | 8.91" |

MODULE SPECIFICATIONS

| | | | |
|-----------------------|------------------------|--------------------------|-------|
| CATALOG NUMBER | KTLM-600-L8-850-24A-CP | | |
| LENGTH | 8.00" | No. of LEDs | 24 |
| WIDTH | 0.70" | Color Temperature | 5000K |



KT-EMRG-LED-12-1200-K1

CONSTANT WATTAGE LED EMERGENCY BACK-UP

WIRING DIAGRAMS

1. KIT WIRING DIAGRAM WITH EXISTING POWER SUPPLY

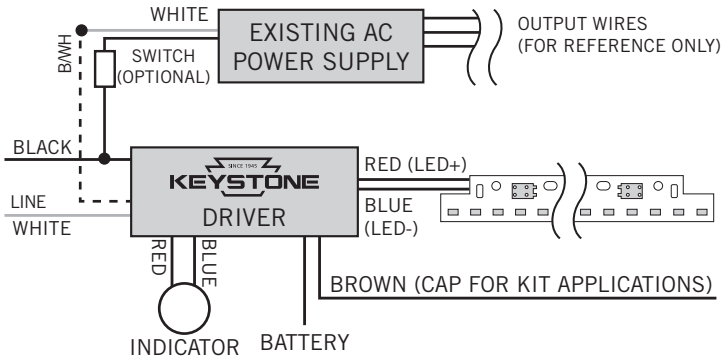

2. KIT WIRING DIAGRAM WITH DIRECT DRIVE LED TUBE FIXTURE

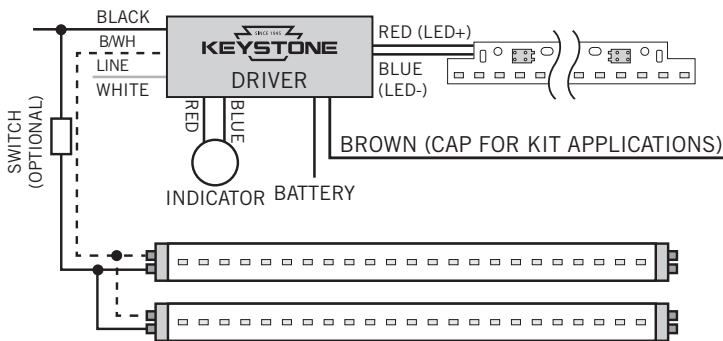

ORDERING INFORMATION

| ORDER CODE | DESCRIPTION | PACKAGING STYLE | PACK QTY. | ITEM STATUS |
|---------------------------|---|-----------------------|-----------|-------------|
| KT-EMRG-LED-12-1200-K1-IP | LED Emergency Driver Kit with Battery and 0.7" x 8" 1200 lumen LED Module | Individually Packaged | 1 | Active |

CATALOG NUMBER BREAKDOWN

KT-EMRG-LED-12-1200-K1

