

<b>PRODUCT SPECIFICATION SHEET</b>	<b>I T C</b>
<b>15kV 200A Loadbreak Insulated Cap</b>	<b>160DRG</b>
GROUND CABLE	<b>w/ Ground Lead</b>

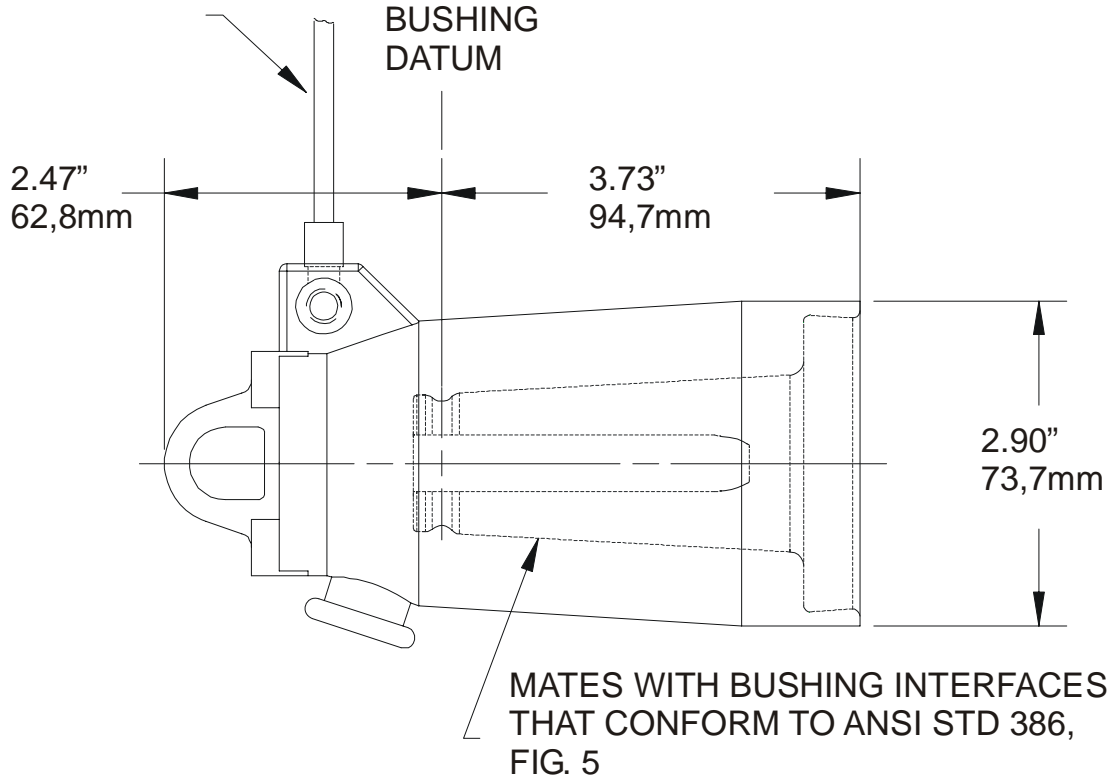

**Application:**

ELASTIMOLD 160DRG insulated caps w/ ground lead (without insulated cuff) are fully shielded, fully submersible, hot stick operable, separable insulated connector designed for energized operation. They are suitable for use on 15kV class loadbreak systems. The 160DRG has an integral ground lead as part of the assembly. The 160DRG is used to “dead-end” the following ELASTIMOLD mating products:

- \* 1601A4 bushing insert
- \* 1602A3R feed-thru insert
- \* 164FT feed-thru
- \* 164 series junctions

**Ratings**

- per ANSI/IEEE Standard 386
- 15kV Voltage Class
- 8.3kV Max Phase-to-Ground - Operating Voltage
- 14.4kV Max Phase-to-Phase
- 95kV BIL - Impulse Withstand (1.2 x 50 microsecond wave)
- 34kV AC - One minute Withstand
- 53kV DC - 15 Minute Withstand
- 11kV AC - Corona Extinction @ 3p.C.sensitivity
- 200 Amp - Continuous and Loadbreak
- 10kA Sym - 10 Cycle Momentary & Fault Close

**Ordering Instruction:**

To order, specify number **160DRG** insulated cap w/ ground lead.

**The 160DRG insulated cap w/ ground lead includes the following:**

1 – Insulated cap	160DRG
1 – Grounding cable #14 AWG, 38”	5000-150-1
1 – Lubricant	82-08
1 – Installation instruction	IS-0892