

TYPE: _____
 CATALOG #: _____
 NOTES: _____



EL-2MRS & 12EL50-2MRS Series

Completely Self-Contained or Heavy Duty Thermoplastic Battery Unit



DISTRIBUTOR SELECT

Features

- Each self-contained unit comes with two (2) 6V MR16 halogen or LED lamps housed in adjustable, gimbal-type assemblies to provide clean, adequate lighting
- High impact thermoplastic construction is UL recognized 94, 5VA
- Sealed, maintenance-free Lead-Calcium batteries
- Reliable integrated circuitry offers 120/277VAC 0.1/0.05A input standard, automatic charging, instantaneous transfer, test switch, long-life LED AC charge monitor, temperature compensated charger, short circuit protection, low battery voltage disconnect, brownout protection, and lock out (automatic battery detection during installation)
- Snap-together thermoplastic housing facilitates mounting in any orientation
- UL924 Listed
- Damp location listing is standard
- 3-year limited warranty
 Detailed warranty terms located at: www.emergi-lite.com/usa/files/EL_Warranty.pdf

Dimensions

Dimensions are approximate and subject to change.

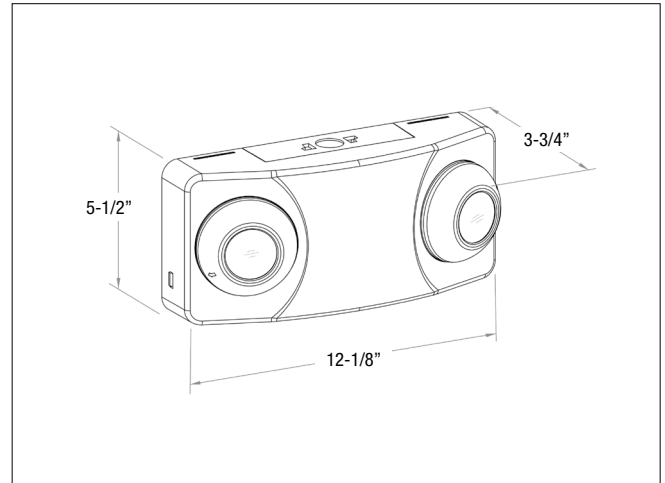

Accessories

DESCRIPTION	PART NUMBER
Replacement MR16 lamp 6V-5W	580.0072-E
Wire Guard	WG13-E
Replacement Battery	860.0004-E
Replacement MR16 LED lamp 6V-4W	580.0097-E

Power Consumption

Series	Battery Type	DC Voltage	Watts to 87-1/2% of rated battery voltage				Dual Voltage	Current Maximum	Power Maximum
			1-1/2 hrs	2 hrs	3 hrs	4 hrs			
EL-2MRS	Lead-Calcium	6V	12	-	-	-	120VAC	.1A	7.5W
EL-2MRS-LA		6V	12	-	-	-	277VAC	.05A	7.5W

How to Order

SERIES	LAMP OPTION
EL= Series	-2MRS= 6V-5W MR16 -2MRS-LA= 6V-4W, MR16 LED

Example: EL-2MRS-LA