

DESCRIPTION:

SNAPNRACK, BONDING MID CLAMP

DRAWN BY:

D.Ryan

SnapNrack™
Solar Mounting Solutions

PART NUMBER(S):

242-02050, 242-02051, 242-02052, 242-02053,
242-02054, 242-02055, 242-02056, 242-02057

REVISION:

A

595 MARKET STREET, 29TH FLOOR • SAN FRANCISCO, CA 94105 USA
PHONE (415) 580-6900 • FAX (415) 580-6902

THE INFORMATION IN THIS DRAWING IS CONFIDENTIAL AND PROPRIETARY. ANY REPRODUCTION, DISCLOSURE, OR USE THEREOF IS PROHIBITED WITHOUT THE WRITTEN CONSENT OF SUNRUN SOUTH LLC.

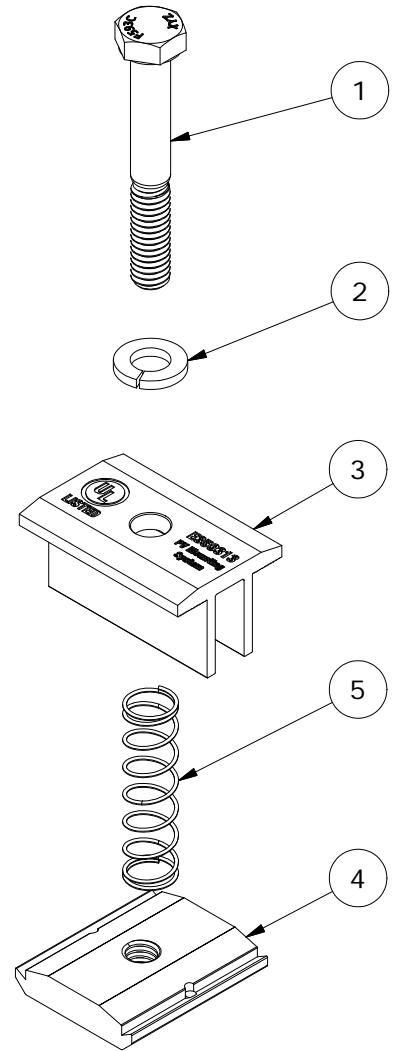
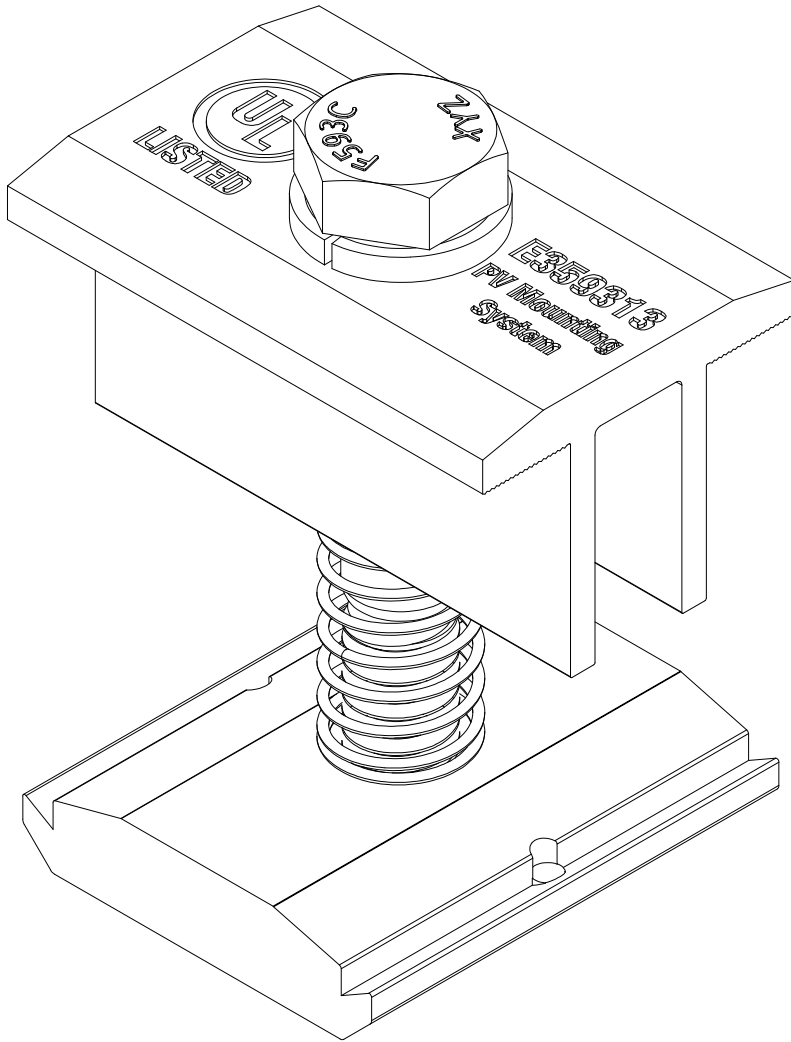

PARTS LIST

ITEM	QTY	DESCRIPTION
1	1	5/16IN-18 SS HCS BOLT, LENGTH VARIES, CLEAR / BLACK
2	1	5/16IN SS SPLIT LOCK WASHER, CLEAR / BLACK
3	1	SNAPNRACK, BONDING MID CLAMP, CLEAR / BLACK
4	1	SNAPNRACK, BONDING CHANNEL NUT
5	1	SNAPNRACK, MID CLAMP SPRING, SS

MATERIALS:

6000 SERIES ALUMINUM, STAINLESS STEEL

OPTIONS:

DESIGN LOAD (LBS):

800

CLEAR / BLACK ANODIZED

ULTIMATE LOAD (LBS):

2400

TORQUE SPECIFICATION:

10+ LB-FT

CERTIFICATION:

UL 2703, FILE E359313

WEIGHT (LBS):

0.16 - 0.18

DESCRIPTION:

SNAPNRACK, BONDING MID CLAMP

DRAWN BY:

D.Ryan

REVISION:

A



PART NUMBER(S):

242-02050, 242-02051, 242-02052, 242-02053,
242-02054, 242-02055, 242-02056, 242-02057

595 MARKET STREET, 29TH FLOOR • SAN FRANCISCO, CA 94105 USA
PHONE (415) 580-6900 • FAX (415) 580-6902

THE INFORMATION IN THIS DRAWING IS CONFIDENTIAL AND PROPRIETARY. ANY REPRODUCTION, DISCLOSURE, OR USE THEREOF IS PROHIBITED WITHOUT THE WRITTEN CONSENT OF SUNRUN SOUTH LLC.

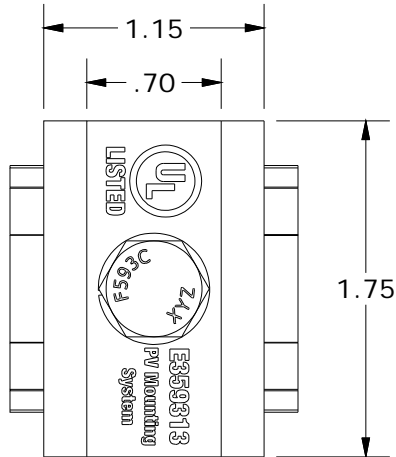

MID CLAMP PROPERTIES		
SKU	BOLT LENGTH (X)	FINISH
242-02050	2.25"	CLEAR
242-02051	2.50"	CLEAR
242-02052	2.75"	CLEAR
242-02053	2.25"	BLACK
242-02054	2.50"	BLACK
242-02055	2.75"	BLACK
242-02056	3.00"	CLEAR
242-02057	3.00"	BLACK

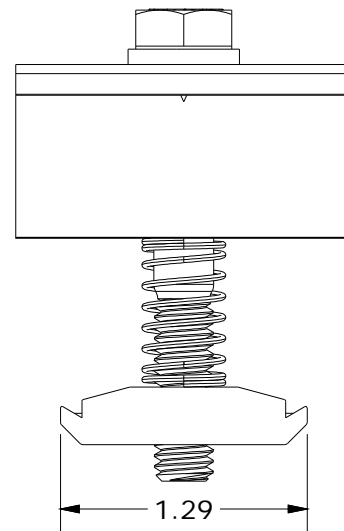
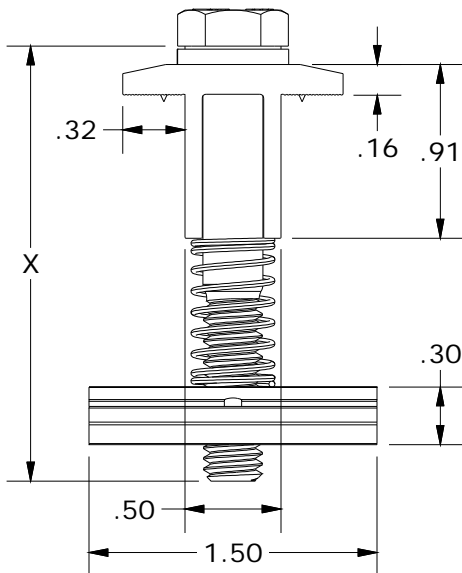

ALL DIMENSIONS IN INCHES