

REV.	DATE	DESCRIPTION	ECO	BY	C'H'K.
A	07/08/2014 00:00:00 AM	DRAWING RELEASED	36644	DD	RD

CATALOG	CONDUCTOR RANGE				CONDUCTOR DIAMETER				TORQUE (IN-LB)	WENCH SIZE	DIMENSIONS		
	GROOVE A (RUN)		GROOVE B (TAP)		GROOVE A (RUN)		GROOVE B (TAP)				L	H	W
	COPPER & ALUMINUM	ACSR, 6201 & 5005	COPPER & ALUMINUM	ACSR, 6201 & 5005	MIN	MAX	MIN	MAX					
UCT26RS	8 SOL.-2/0 STR.	6 STR.-2/0 STR.	8 SOL.-2/0 STR.	6 STR.-2/0 STR.	0.13	0.45	0.13	0.45	200-250	9/16	1.62	2.62	2.50
UCT32RS	1 SOL.-400	2 STR.- 336.4	8 SOL.-4/0 STR.	6 STR.-4/0 STR.	0.29	0.73	0.13	0.56	200-250	9/16	1.62	2.62	2.82

NOTES

- THE BURNDY® FASTAP™ WITH LINEMAN ASSIS™ UTILIZES A SPRING SYSTEM THAT ACTS AS A THIRD HAND TO ASSIST DURING INSTALLATION. THE SYSTEM HELPS SECURE BOTH THE TAP AND RUN CONDUCTORS WHILE INSTALLING ON PRIMARY, SECONDARY, AND SERVICE LINES. THE DUCKBILL HANDLES SIMPLIFIES INSTALLATION BY PROVIDING A HANDLE TO EASILY HOLD THE CONNECTOR WHILE WEARING DIELECTRIC GLOVES. CONDUCTOR SIDE ENTRY FACILITATES INSTALLATION AND HELPS KEEP THE PREFILLED OXIDE INHIBITOR IN THE CONNECTOR TO MAXIMIZE CONNECTOR LIFE.
- ACCOMMODATES: ALUMINUM, COPPER, ACSR, AAAC, ACAR, STEEL WIRE. CONNECTOR IS NOT RECOMMENDED FOR COPPER TO COPPER APPLICATIONS.
- MATERIAL FOR BASE MODEL
 - A. CASTINGS: CAST ALUMINUM
 - B. HARDWARE: GALVANIZED STEEL
 - C. SPRING: STAINLESS STEEL
- CONNECTOR IS STRIPSEALED AT THE FACTORY TO REMOVE ALUMINUM OXIDES AND SEALED TO PROVIDE A CLEAN SURFACE TO MAXIMIZE ELECTRICAL CONTACT DURING INSTALLATION
- PENETROX™ OXIDE INHIBITOR APPLIED TO CABLE GROOVES AT THE FACTORY TO LIMIT OXIDE GROWTH AFTER INSTALLATION AND TO INCREASE THE LIFE OF THE CONNECTION.
- REMOVE "S" IF NON PREFILLED PENETROX CONNECTOR IS DESIRED. EXAMPLE: UCT26R
- FOR STAINLESS STEEL HARDWARE ADD "SS" TO END OF CATALOG NUMBER. EXAMPLE: UTC26RSSS
- TO INCLUDE A COVER WITH THE CONNECTOR ADD "C". EXAMPLE: UTC26RSC. COVER MAY BE PURCHASED SEPARATELY USE CATALOG NUMBER UCTCOVER
- TO ADD A SHEAR NUT TO ENSURE PROPER TIGHTENING TORQUE ADD "HN" TO END OF CATALOG NUMBER. EXAMPLE: UTC26RSHN.

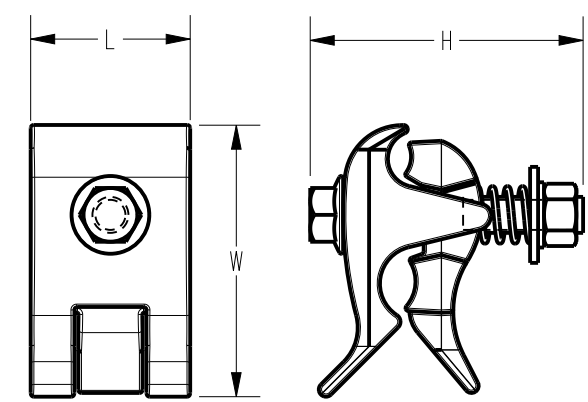
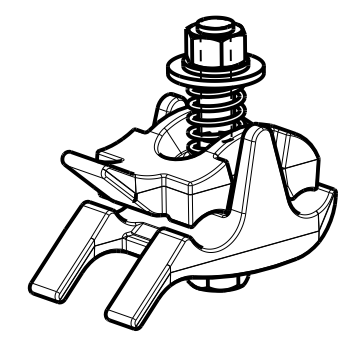

REV: PE0200

TO ORDER BURNDY® PRODUCTS CALL		FASTAP™	
UNITED STATES: 1-800-346-4175 (LONDONDERRY, NH)		ITEM NO: --	
CANADA: 1-800-361-6975 (QUEBEC) 1-800-387-6487 (ALL OTHER PROVINCES)		CAT. NO: SEE TABLE ABOVE	
FOR PRODUCT INFO: http://www.burndy.com		DRAWN BY: DDOBRIKSI 7/3/14	
		CHECKER: R.DeFrance 7/14/14	
		DSN APPVL: R.DeFrance 7/14/14	
		MFG APPVL: -- --	
		QA APPVL: J.Brodeur 7/3/14	
		MKT APPVL: J.Hall 7/2/14	
		SCALE: 1:1	
		DRAWING NO	
		PROJECT #: --	
		SIZE	
		DOCUMENT TYPE: --	
		B	
		50045569	
		SHEET 1 OF 1	
		A	

