

DESCRIPTION:

**SNAPRACK, STANDARD RAIL**

DRAWN BY:

D. Ryan



PART NUMBER(S):

232-01067, 232-01068, 232-01069, 232-01070,  
232-02112, 232-02113

REVISION:

**A**

595 MARKET STREET, 29TH FLOOR • SAN FRANCISCO, CA 94105 USA  
PHONE (415) 580-6900 • FAX (415) 580-6902

THE INFORMATION IN THIS DRAWING IS CONFIDENTIAL AND PROPRIETARY. ANY REPRODUCTION, DISCLOSURE, OR USE THEREOF IS PROHIBITED WITHOUT THE WRITTEN CONSENT OF SUNRUN SOUTH LLC.

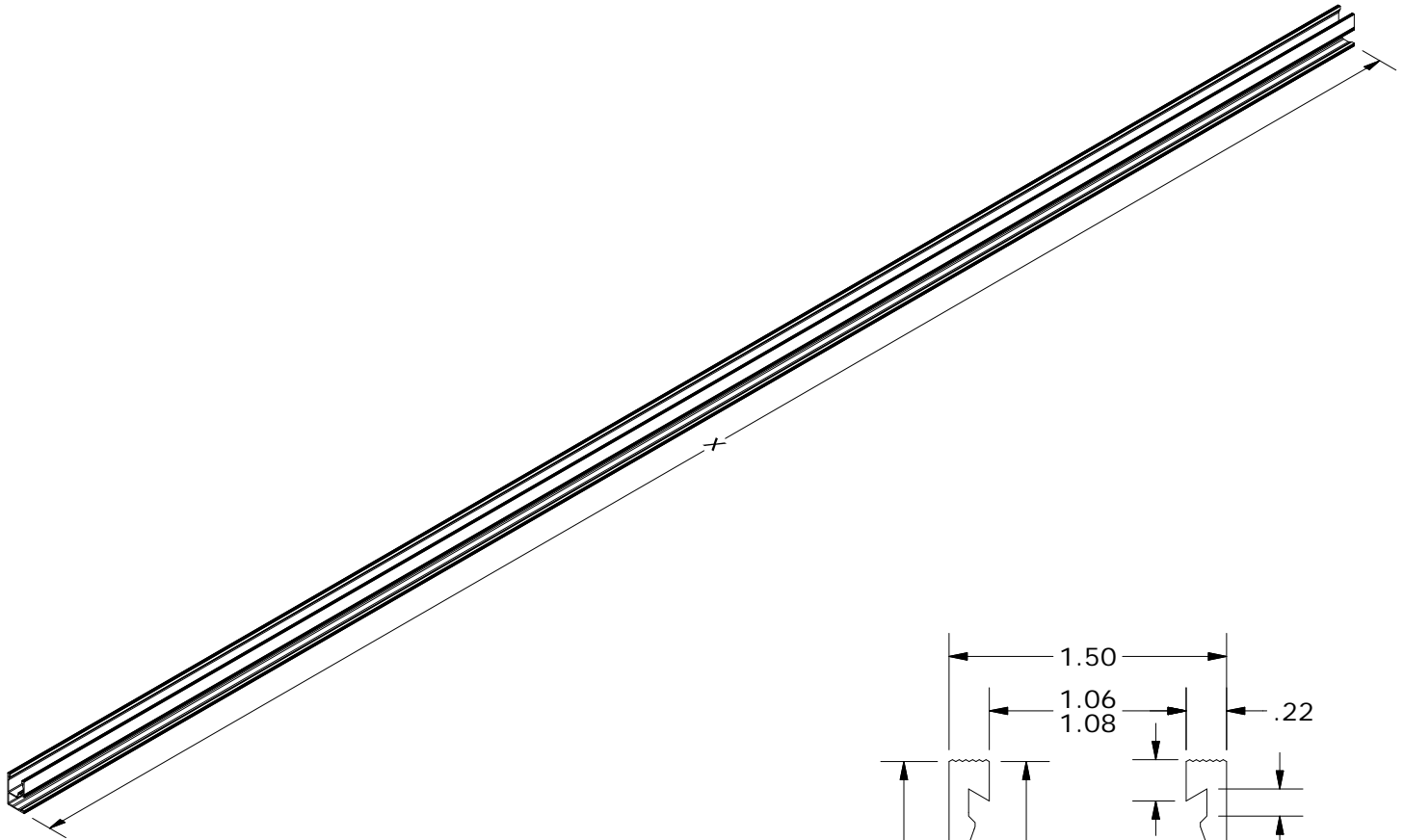

STANDARD RAIL PROPERTIES		
SKU	RAIL LENGTH (X)	FINISH
232-01067	122"	BLACK
232-01068	122"	CLEAR
232-01069	162"	BLACK
232-01070	162"	CLEAR
232-02112	122"	MILL
232-02113	162"	MILL

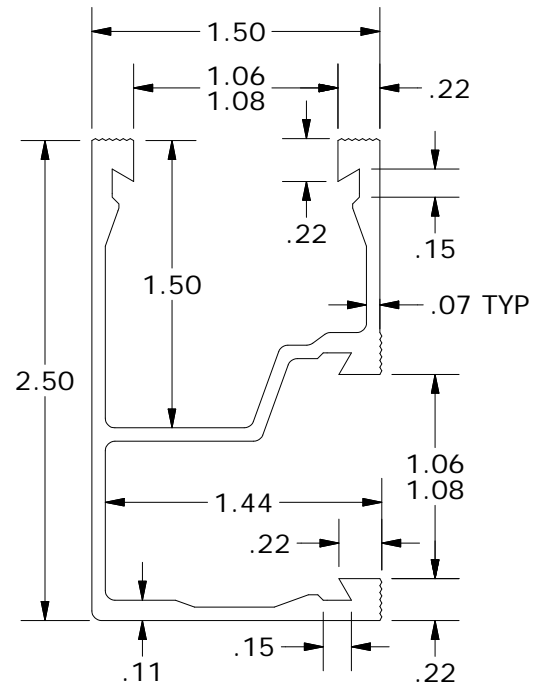

ALL DIMENSIONS IN INCHES

MATERIALS:	6000 SERIES ALUMINUM, STAINLESS STEEL	OPTIONS:
DESIGN LOAD (LBS):	N/A	CLEAR / BLACK ANODIZED
ULTIMATE LOAD (LBS):	N/A	MILL FINISH
TORQUE SPECIFICATION:	N/A LB-FT	122" / 162" LENGTHS
CERTIFICATION:	UL 2703, FILE E359313	BOXES OF 2 / 6
WEIGHT (LBS):	7.65 - 10.16	BUNDLES OF 112