

T&B Liquidtight Fittings

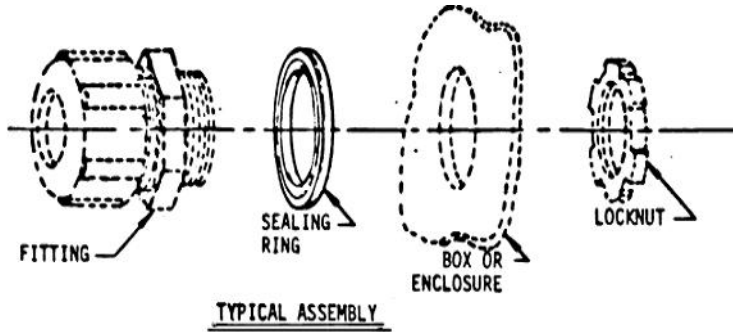

CAT. NO.	FIG.	HUB SIZE	± .01 A	± .020 B	± .01 C	± .020 D	± .015 E	± .030 F
*5299	1	*1/4"	.80	.555	.08	.11	.010	-
*5261	1	*3/8"	.95	.690	.08	.11	.010	-
5262	2	1/2"	1.16	.860	.10	.177	.030	.750
*5262-5000								
5263	2	3/4"	1.49	1.070	.12	.194	.030	.930
5264	2	1"	1.75	1.335	.12	.194	.030	1.170
5265	2	1-1/4"	2.15	1.680	.14	.220	.040	1.520
5266	2	1-1/2"	2.42	1.935	.15	.230	.040	1.750
5267	2	2"	2.92	2.340	.15	.230	.040	2.230
5268	1	2-1/2"	3.44	2.910	.15	.23	.045	-
5269	1	3"	4.08	3.540	.15	.23	.045	-
5270	1	4"	5.29	4.550	.22	.31	.045	-

*SUGGESTED KNOCKOUT SIZE: 1/4 = .578 +/- 1/16

*NOT UL LISTED 3/8 = .703 +/- 1/16

*Quantity = 5000

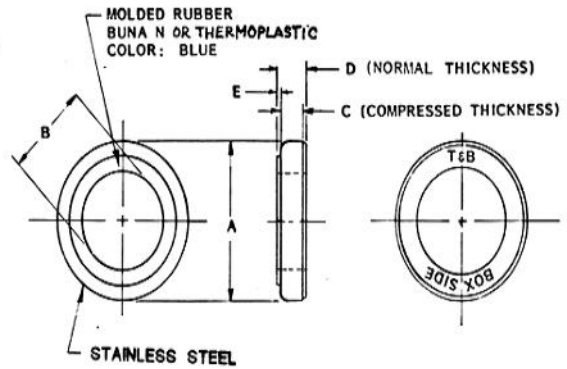

FIG. 1

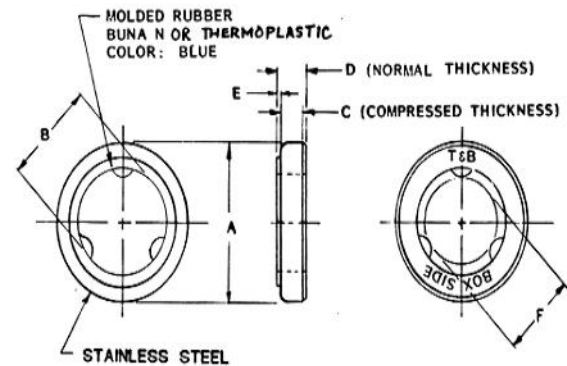

FIG. 2

GENERAL NOTES

1. ALL DIMENSIONS ARE FOR REFERENCE ONLY.
2. DIMENSIONS IN BRACKETS [] ARE IN METRIC UNITS.

www.tnb.com

Thomas & Betts
A Member of the ABB Group

REVISIONS

0 SEE ERN (2016899)
FOR APPROVAL SIGNATURES
& RELEASE DATE.
PROJECT NO: RM401890

DESCRIPTION:

SEALING RINGS FOR LIQUID TIGHT AND DUST TIGHT SEALING (ALL T&B FITTINGS)

ORIGINAL PROJECT NO / (ERN NO)

RM401890 / (2016899)

SHEET NO:

1 OF 1

REV. NO:

0

DRAWING NO:

WSD-001558