

DESCRIPTION:
SNAPRACK, ULTRA RAIL MOUNTING HARDWARE

DRAWN BY:
 mwatkins



PART NUMBER(S):
242-01229

REVISION:
A

595 MARKET STREET, 29TH FLOOR • SAN FRANCISCO, CA 94105 USA
 PHONE (415) 580-6900 • FAX (415) 580-6902

THE INFORMATION IN THIS DRAWING IS CONFIDENTIAL AND PROPRIETARY. ANY REPRODUCTION, DISCLOSURE, OR USE THEREOF IS PROHIBITED WITHOUT THE WRITTEN CONSENT OF SUNRUN SOUTH LLC.

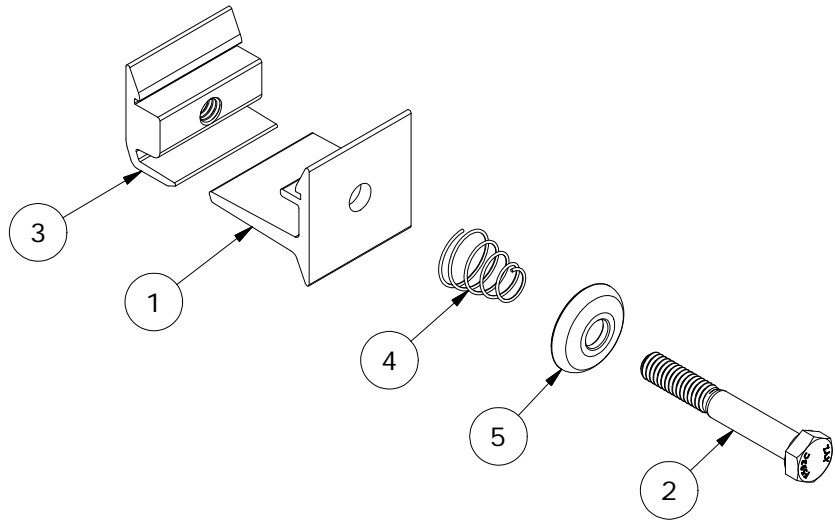
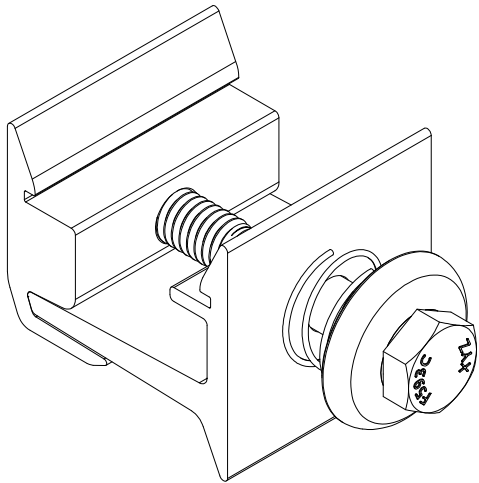

PARTS LIST		
ITEM	QTY	DESCRIPTION
1	1	SNAPNRACK, ULTRA RAIL MOUNT THRU PRC, SILVER
2	1	5/16IN-18 X 2-1/4IN SS HCS BOLT
3	1	SNAPNRACK, ULTRA RAIL MOUNT TAPPED PRC, SILVER
4	1	SNAPNRACK, ULTRA RAIL MOUNT SPRING, SS
5	1	SNAPNRACK, ULTRA RAIL MOUNT SPRING CAGE, 6061-T6 AL

MATERIALS:	6000 SERIES ALUMINUM, STAINLESS STEEL	OPTIONS:
DESIGN LOAD (LBS):	N/A	
ULTIMATE LOAD (LBS):	N/A	
TORQUE SPECIFICATION:	12 LB-FT	
CERTIFICATION:	UL 2703, FILE E359313	
WEIGHT (LBS):	0.19	

DESCRIPTION:
SNAPNRACK, ULTRA RAIL MOUNTING HARDWARE

DRAWN BY:
mwatkins



PART NUMBER(S):
242-01229

REVISION:
A

595 MARKET STREET, 29TH FLOOR • SAN FRANCISCO, CA 94105 USA
PHONE (415) 580-6900 • FAX (415) 580-6902

THE INFORMATION IN THIS DRAWING IS CONFIDENTIAL AND PROPRIETARY. ANY REPRODUCTION, DISCLOSURE, OR USE THEREOF IS PROHIBITED WITHOUT THE WRITTEN CONSENT OF SUNRUN SOUTH LLC.

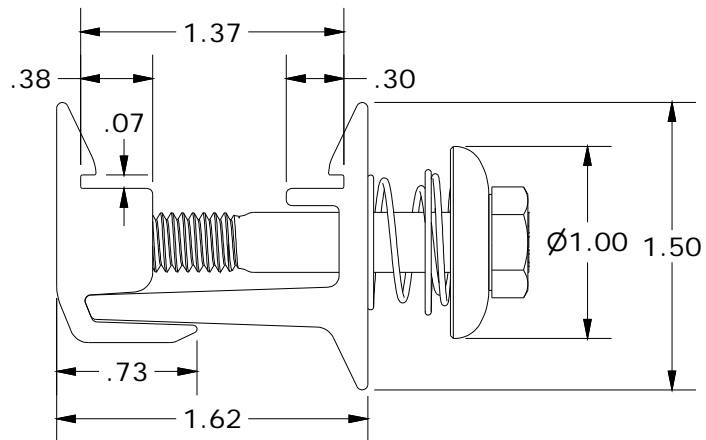
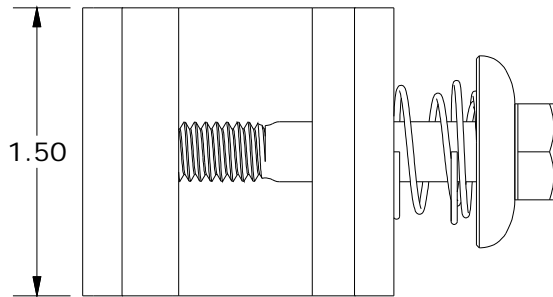

ALL DIMENSIONS IN INCHES