

DESCRIPTION:
SNAPNRACK, UR-60 RAIL

PART NUMBER(S):
232-02481, 232-02482, 232-02483

DRAWN BY:
 mwatkins

REVISION:
A

SnapNrack™
 Solar Mounting Solutions

595 MARKET STREET, 29TH FLOOR • SAN FRANCISCO, CA 94105 USA
 PHONE (415) 580-6900 • FAX (415) 580-6902

THE INFORMATION IN THIS DRAWING IS CONFIDENTIAL AND PROPRIETARY. ANY REPRODUCTION, DISCLOSURE, OR USE THEREOF IS PROHIBITED WITHOUT THE WRITTEN CONSENT OF SUNRUN SOUTH LLC.

UR-60 RAIL PROPERTIES	
SKU	FINISH
232-02481	MILL
232-02482	CLEAR
232-02483	BLACK

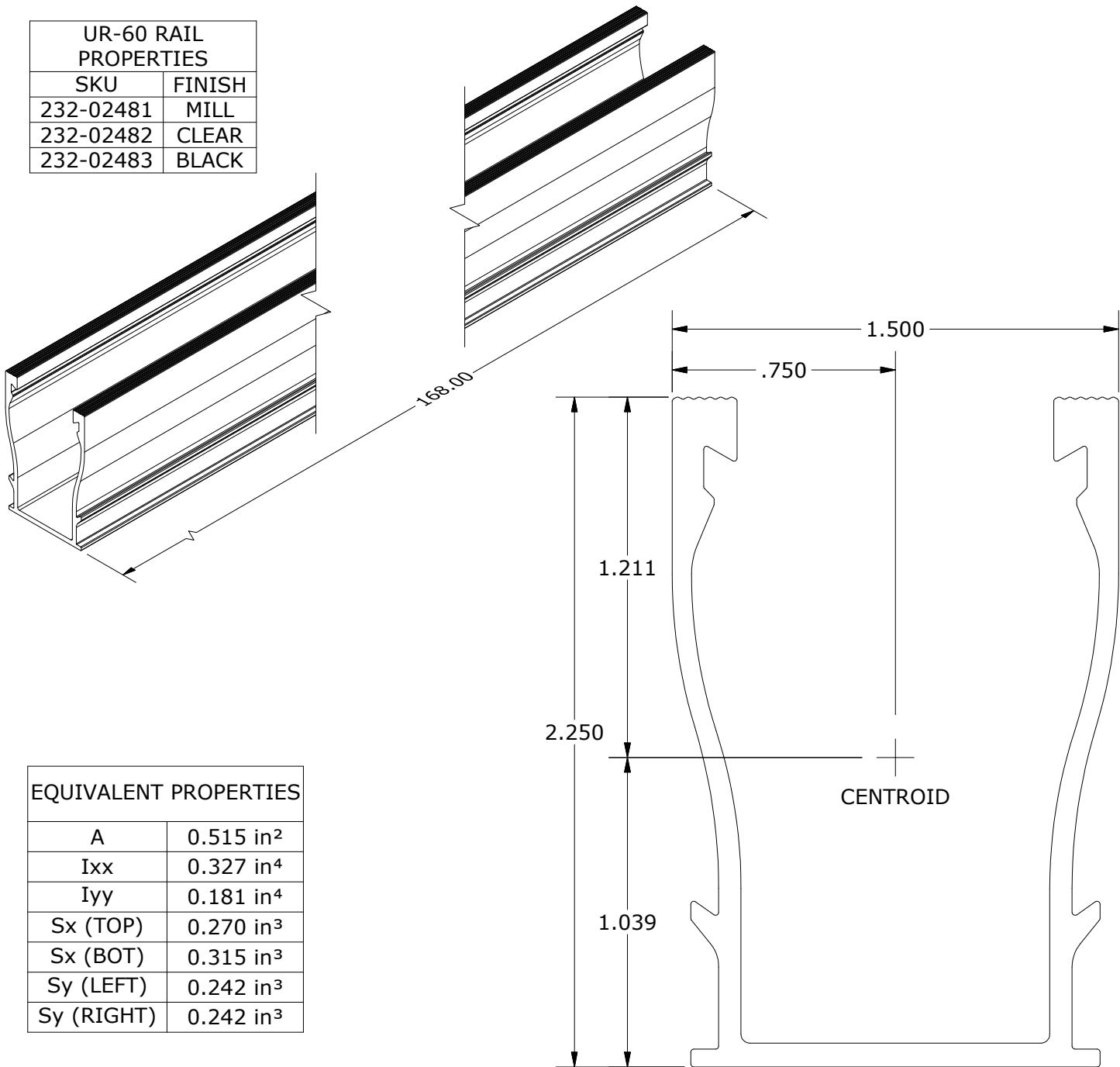

EQUIVALENT PROPERTIES	
A	0.515 in ²
I _{xx}	0.327 in ⁴
I _{yy}	0.181 in ⁴
S _x (TOP)	0.270 in ³
S _x (BOT)	0.315 in ³
S _y (LEFT)	0.242 in ³
S _y (RIGHT)	0.242 in ³

ALL DIMENSIONS IN INCHES

MATERIALS:	6000 SERIES ALUMINUM	OPTIONS:
DESIGN LOAD (LBS):	N/A	CLEAR / BLACK ANODIZED
ULTIMATE LOAD (LBS):	N/A	MILL FINISH
TORQUE SPECIFICATION:	N/A LB-FT	BUNDLES OF 120
CERTIFICATION:	UL 2703, FILE E359313	BOXES OF 8
WEIGHT (LBS):	8.46	